



**REGULAR MEETING AGENDA**

**Date:** 8/17/2021  
**Time:** 5:00 p.m.  
**Location:** [Zoom.us/join](https://zoom.us/join) – ID# 998 8073 4930

**NOVEL CORONAVIRUS, COVID-19, EMERGENCY ADVISORY NOTICE**

On March 19, 2020, the Governor ordered a statewide stay-at-home order calling on all individuals living in the State of California to stay at home or at their place of residence to slow the spread of the COVID-19 virus. Additionally, the Governor has temporarily suspended certain requirements of the Brown Act. For the duration of the shelter in place order, the following public meeting protocols will apply.

Teleconference meeting: All members of the City Council, city staff, applicants, and members of the public will be participating by teleconference. To promote social distancing while allowing essential governmental functions to continue, the Governor has temporarily waived portions of the open meetings act and rules pertaining to teleconference meetings. This meeting is conducted in compliance with the Governor Executive Order N-25-20 issued March 12, 2020, and supplemental Executive Order N-29-20 issued March 17, 2020.

- How to participate in the closed session and regular meeting
  - Submit a written comment online up to 1-hour before the meeting start time:  
[menlopark.org/publiccommentAugust17](https://menlopark.org/publiccommentAugust17) \*
  - Access the meeting real-time online at:  
[Zoom.us/join](https://zoom.us/join) – Meeting ID 998 8073 4930
  - Access the meeting real-time via telephone at:  
(669) 900-6833  
Meeting ID 998 8073 4930  
Press \*9 to raise hand to speak

\*Written public comments are accepted up to 1-hour before the meeting start time. Written messages are provided to the City Council at the appropriate time in their meeting.

- Watch meeting:
  - Cable television subscriber in Menlo Park, East Palo Alto, Atherton, and Palo Alto:  
Channel 26
  - Online:  
[menlopark.org/streaming](https://menlopark.org/streaming)

Note: City Council closed sessions are not broadcast online or on television and public participation is limited to the beginning of closed session.

Subject to Change: Given the current public health emergency and the rapidly evolving federal, state, county and local orders, the format of this meeting may be altered or the meeting may be canceled. You may check on the status of the meeting by visiting the City's website [www.menlopark.org](https://www.menlopark.org). The instructions for logging on to the webinar and/or the access code is subject to change. If you have difficulty accessing the webinar, please check the latest online edition of the posted agenda for updated information ([menlopark.org/agenda](https://menlopark.org/agenda)).

According to City Council policy, all meetings of the City Council are to end by midnight unless there is a super majority vote taken by 11:00 p.m. to extend the meeting and identify the items to be considered after 11:00 p.m.

**Closed Session ([Zoom.us/join](https://zoom.us/join) – ID# 998 8073 4930)**

**A. Call To Order**

**B. Roll Call**

**C. Agenda Review**

Agenda Review provides advance notice to members of the public and City staff of any modifications to the agenda order and any requests from City Councilmembers under City Councilmember reports.

**D. Closed Session**

Public Comment on these items will be taken before adjourning to Closed Session.

- D1. CONFERENCE WITH LEGAL COUNSEL - EXISTING LITIGATION (Government Code § 54956.9)  
Michael Zeleny v. Rob Bonta, et al (Case No. 17-cv-07357-RS)  
Claimant: Michael Zeleny  
Agency Claimed Against: City of Menlo Park
- D2. CONFERENCE WITH LEGAL COUNSEL—EXISTING LITIGATION (Paragraph (1) of subdivision (d) of Section 54956.9) Case number: 21-CIV-01717
- D3. Closed session conference pursuant to Government Code §54957(b)(1) regarding public employee performance evaluation of the City Attorney

**E. Adjournment**

**Regular Session ([Zoom.us/join](https://zoom.us/join) – ID# 998 8073 4930)**

**F. Call To Order**

**G. Roll Call**

**H. Report from Closed Session**

**I. Presentations and Proclamations**

- I1. Certificates of Recognition: Boy Scout Troop 222 ([Attachment](#))

**J. Public Comment**

Under “Public Comment,” the public may address the City Council on any subject not listed on the agenda. Each speaker may address the City Council once under public comment for a limit of three minutes. Please clearly state your name and address or political jurisdiction in which you live. The City Council cannot act on items not listed on the agenda and, therefore, the City Council cannot

respond to non-agenda issues brought up under public comment other than to provide general information.

#### **K. Study Session**

- K1. Provide direction on parks projects and the use of remaining Measure T bond funds ([Staff Report #21-153-CC](#)) ([Presentation](#))

#### **L. Consent Calendar**

- L1. Receive Finance and Audit Committee's recommendation and adopt Resolution No. 6651 approving the 2021-22 investment policy for the City and the former Community Development Agency of Menlo Park ([Staff Report #21-146-CC](#))
- L2. Approve the 2021-22 Finance and Audit Committee work plan ([Staff Report #21-147-CC](#))
- L3. Adopt Resolution No. 6652 to reduce the posted speed limit in school zones consistent with the California Vehicle Code ([Staff Report #21-149-CC](#))
- L4. Award an on-call construction contract to Catos General Engineering, Inc. for the on-call asphalt and concrete repair services project ([Staff Report #21-150-CC](#))
- L5. Award a construction contract to Terramark General Engineering Contractors, Inc. for the Sharon Park walkways reconstruction project ([Staff Report #21-151-CC](#))
- L6. Award a construction contract to Tricon Construction for the Burgess Pool chemical room renovations ([Staff Report #21-152-CC](#))
- L7. Adopt Resolution No. 6653 to authorize the city manager to accept the grant deed for 1155 Merrill St. Unit 209, execute all documents necessary to complete the purchase and approve the appropriation of below market rate housing funds not to exceed \$355,000 to purchase and retain the property in the below market rate housing program ([Staff Report #21-154-CC](#))
- L8. Establish the Reimagining Public Safety Ad Hoc Subcommittee and appoint City Councilmembers Taylor and Wolosin ([Staff Report #21-155-CC](#))

#### **Recess**

#### **M. Regular Business**

- M1. Adopt Resolution No. 6648 to ratify successor agreement between the City of Menlo Park and the Service Employees International Union Local 521 expiring June 30, 2023 ([Staff Report #21-144-CC](#)) ([Presentation](#))
- M2. Adopt Resolution No. 6649 to ratify a successor agreement between the City of Menlo Park and the American Federation of State, County, and Municipal Employees Local 829 expiring June 30, 2023 ([Staff Report #21-145-CC](#)) ([Presentation](#))
- M3. Receive report and recommendation from the city manager recruitment services request for proposals subcommittee, select a firm to perform the recruitment, authorize Mayor to execute

professional services agreement with the selected firm, and appoint a City Council Ad Hoc Subcommittee for City Manager Recruitment ([Staff Report #21-156-CC](#))

- M4. Adopt Resolution No. 6650 of the City Council of the City of Menlo Park determining that the City Council shall take an appeal of the Planning Commission's June 21, 2021, approval of the Menlo Uptown Development Project ([Staff Report #21-148-CC](#))

## **N. Informational Items**

- N1. City Council agenda topics: August to September 2021 ([Staff Report #21-157-CC](#))
- N2. Update on the Menlo Park local hazard mitigation plan annex to the San Mateo County hazard mitigation plan ([Staff Report #21-158-CC](#))

## **O. City Manager's Report**

## **P. City Councilmember Reports**

- P1. Confirm voting delegate for the League of California Cities annual conference ([Attachment](#))

## **Q. Adjournment**

At every regular meeting of the City Council, in addition to the public comment period where the public shall have the right to address the City Council on any matters of public interest not listed on the agenda, members of the public have the right to directly address the Council on any item listed on the agenda at a time designated by the chair, either before or during the City Council's consideration of the item.

At every special meeting of the City Council, members of the public have the right to directly address the City Council on any item listed on the agenda at a time designated by the chair, either before or during consideration of the item. For appeal hearings, appellant and applicant shall each have 10 minutes for presentations.

If you challenge any of the items listed on this agenda in court, you may be limited to raising only those issues you or someone else raised at the public hearing described in this notice, or in written correspondence delivered to the City of Menlo Park at, or prior to, the public hearing.

Any writing that is distributed to a majority of the City Council by any person in connection with an agenda item is a public record (subject to any exemption under the Public Records Act) and is available by request by emailing the city clerk at [jaherren@menlopark.org](mailto:jaherren@menlopark.org). Persons with disabilities, who require auxiliary aids or services in attending or participating in City Council meetings, may call the City Clerk's Office at 650-330-6620.

Agendas are posted in accordance with Government Code Section 54954.2(a) or Section 54956. Members of the public can view electronic agendas and staff reports by accessing the City website at [menlopark.org/agenda](http://menlopark.org/agenda) and can receive email notification of agenda and staff report postings by subscribing to the "Notify Me" service at [menlopark.org/notifyme](http://menlopark.org/notifyme). Agendas and staff reports may also be obtained by contacting City Clerk at 650-330-6620. (Posted: 8/12/2021)



**REGULAR MEETING AGENDA**

**Date:** 8/17/2021  
**Time:** 5:00 p.m.  
**Location:** Teleconference

**EARLY STAFF REPORT RELEASE NOTICE**

Pursuant to the requirements, the following staff report is being released 15-days in advance of the regular City Council meeting:

Resolution No. 6649 to ratify a successor agreement between the City of Menlo Park and the American Federation of State, County, and Municipal Employees Local 829 expiring June 30, 2023  
([Staff Report #21-145-CC](#))

This Notice is posted in accordance with Government Code §54954.2(a) or §54956. Members of the public can view electronic agendas and staff reports by accessing the City website at [www.menlopark.org](http://www.menlopark.org) and can receive e-mail notification of agenda and staff report postings by subscribing to the "Notify Me" service at [menlopark.org/notifyme](http://menlopark.org/notifyme). Agendas and staff reports may also be obtained by contacting the City Clerk's Office at 650-330-6620. (Posted 7/26/2021)



**REGULAR MEETING AGENDA**

**Date:** 8/17/2021  
**Time:** 5:00 p.m.  
**Location:** Teleconference

**EARLY STAFF REPORT RELEASE NOTICE**

Pursuant to the requirements, the following staff report is being released 15-days in advance of the regular City Council meeting:

Adopt Resolution No. 6648 to ratify successor agreement between the City of Menlo Park and the Service Employees International Union Local 521 expiring June 30, 2023 ([Staff Report #21-144-CC](#))

This Notice is posted in accordance with Government Code §54954.2(a) or §54956. Members of the public can view electronic agendas and staff reports by accessing the City website at [www.menlopark.org](http://www.menlopark.org) and can receive e-mail notification of agenda and staff report postings by subscribing to the "Notify Me" service at [menlopark.org/notifyme](http://menlopark.org/notifyme). Agendas and staff reports may also be obtained by contacting the City Clerk's Office at 650-330-6620. (Posted 7/26/2021)

# CERTIFICATE OF RECOGNITION

Presented to

**Ron Freeman**

Boy Scout Troup 222

*for attaining the rank of*

**Eagle Scout**

*Presented this seventeenth day of August, 2021*

DocuSigned by:

*Drew Combs*

52C1D491348F4A3...

\_\_\_\_\_  
Drew Combs, Mayor  
City of Menlo Park

# CERTIFICATE OF RECOGNITION

Presented to

**William Francis Killmond**

Boy Scout Troup 222

*for attaining the rank of*

**Eagle Scout**

*Presented this seventeenth day of August, 2021*

DocuSigned by:

*Drew Combs*

52C1D491348F4A3...

Drew Combs, Mayor  
City of Menlo Park



# CERTIFICATE OF RECOGNITION

Presented to

**Kelvin David Rout**

Boy Scout Troup 222

*for attaining the rank of*

**Eagle Scout**

*Presented this seventeenth day of August, 2021*

DocuSigned by:

*Drew Combs*

52C1D491348F4A3...

Drew Combs, Mayor  
City of Menlo Park

# CERTIFICATE OF RECOGNITION

Presented to

**Mateo David Sabio Paese**

Boy Scout Troup 222

*for attaining the rank of*

**Eagle Scout**

*Presented this seventeenth day of August, 2021*

DocuSigned by:

*Drew Combs*

52C1D491348F4A3...

Drew Combs, Mayor  
City of Menlo Park

# CERTIFICATE OF RECOGNITION

Presented to

**Gianluca Andrew Shinn**

Boy Scout Troup 222

*for attaining the rank of*

**Eagle Scout**

*Presented this seventeenth day of August, 2021*

DocuSigned by:

*Drew Combs*

52C1D491348F4A3...

\_\_\_\_\_  
Drew Combs, Mayor  
City of Menlo Park



**STAFF REPORT**

**City Council**

**Meeting Date:**

**8/17/2021**

**Staff Report Number:**

**21-153-CC**

**Study Session:**

**Provide direction on parks projects and the use of remaining Measure T bond funds**

**Recommendation**

Staff recommends the City Council provide direction on the following options for the use of remaining Measure T bond funds for parks projects:

- \$8.8 million – maximum amount needed for Menlo Park Community Campus (MPCC) only; or
- \$14.3 million – total remaining amount in order to deliver additional parks projects.

**Policy Issues**

The City Council must authorize the issuance of bonds. The City has \$14,315,000 remaining “new money” bonding capacity under Measure T. Through development of the funding plan for the MPCC, the City Council has identified the use of up to \$8.8 million in Measure T. To meet the required schedule milestones for MPCC, an action item would be scheduled later on the September 14, 2021 agenda. Staff is therefore seeking City Council direction on whether other projects should be funded with Measure T bonds as part of this round of issuance.

**Background**

Measure T bond fund

At an election held November 6, 2001, the City submitted the following Measure T to the registered voters of the City, and at least two-thirds of those voting on the proposition were in favor:

“To renovate and expand the City's parks and recreation facilities, shall the City of Menlo Park be authorized to issue \$38,000,000 in General Obligation Bonds phased over several years for the construction, acquisition, and improvement of such facilities and all costs incident thereto; provided that at the time any bond is issued, the highest tax rate required to service all bonds authorized by this measure and issued shall not be in excess of \$14 per \$100,000 in assessed valuation?”

Menlo Park issued Measure T authorized bonds in 2002 for \$13,245,000, and, in 2009 totaling for \$10,440,000. Net of the previously issued bonds, \$14,315,000 debt capacity remains.

A list of completed Measure T-funded projects is provided in Attachment A.

Parks master planning efforts

On October 15, 2019, the City Council accepted the Parks and recreation facilities master plan (Attachment B.) Following a robust community engagement process and feedback from the Parks and Recreation Commission, the Plan included 123 recommendations, of which 44 were complex, capital projects that required further prioritization and future funding to be completed. The prioritization framework was detailed

in the Plan (Chapter 6), and resulted in 14 projects identified in the highest priority “Tier 1” ranking system and are summarized in Table 1 below. The Plan identified Measure T bonds as possible funding source to deliver some of these projects. Based on order of magnitude cost estimates for the remaining unfunded projects, staff anticipates funding needs of approximately \$20 to \$40 million to complete these Tier 1 projects. In addition, the Bedwell Bayfront Park Master Plan (Attachment C) identified an additional approximate \$11 to 13 million in needs for park improvements (escalated to 2021 dollars from plan estimates prepared in 2017.)

**Table 1: Parks and recreation master plan priority recommendations**

Facility/Park	Recommendation	Status
1 Belle Haven multigenerational community campus	Complete detailed feasibility study	Fully funded. Now called the MPCC. Construction is underway.
2 Bedwell Bayfront Park	Follow recommendations of Bedwell Bayfront park master plan (Attachment C)	Entry project design underway, supported by \$500,000 priority conservation area grant toward the approximate \$1.5 million project cost. The project will improve aesthetics at the park entry, improve bike and pedestrian access, and construct a new roundabout and gated entry. Construction is targeted to begin in 2022 upon the completion of the current flood control project constructing an underground flood diversion channel under the park entry at the same location.
3 Burgess Park	Reconfigure baseball diamond for more flexible and efficient multisport overlays	Not funded/started
4 Burgess Pool	Evaluate installing permanent retractable dome	Feasibility study was initiated in 2019 to analyze potential dome replacement options, but is currently on hold.
5 Burgess Park	Consider artificial turf to increase all season/weather play	Not funded/started
6 Willow Oaks Park	Complete improvements to dog park and complete restroom	Currently funded, though project likely to need additional funding. Playground renovation and bike connector also being considered simultaneously. Design contract initiated in early 2021 and community engagement underway.
7 Sharon Park	Upgrade park infrastructure, pathways, landscaping, lighting	Park pathway reconstruction bid award scheduled for August 17, 2021. Anticipated construction completion by fall 2021. Other elements not funded/started.

Table 1: Parks and recreation master plan priority recommendations		
Facility/Park	Recommendation	Status
8 Kelly Park	When multiuse trail is installed along Dumbarton Corridor, ensure safe and direct access.	This project was incorporated into the Transportation Master Plan adopted in 2020. Preliminary alignment options have been reviewed in conjunction with work at the Menlo Park Community Campus project and the Commonwealth Corporate Center project (162-164 Jefferson Drive) to ensure future construction does not preclude this trail and railroad crossing.
9 Menlo Children’s Center	Evaluate ability to renovate existing building, removing wall, create kitchen, storage, reception space	Not funded/started
10 Burgess Park	Renovate existing playground	Design funded. Design contract initiated in early 2021 to be performed simultaneously with Willow Oaks Park playground.
11 Nealon Park	Consider relocating dog park from sports field to another site in park	Not funded/started
12 Hamilton Park	Add barbecue and shade structure	Not funded/started
13 Karl E. Clark Park	Consider picnic area or community garden	Not funded/started
14 Burgess Park	Consider expansion of Snack Shack and add shade and seating	Not funded/started

Other parks project funding sources

In addition to Measure T bonds, the City also uses recreation in-lieu fees from residential development to fund capital construction of new parks and recreation facilities. General capital funds are also used for annual maintenance activities, including park pathway repairs, tennis court rehabilitation and maintenance, pool maintenance and sports field maintenance. These funding sources alone do not provide sufficient funding for the needs identified in the Parks and recreation and Bedwell Bayfront Park master plans.

**Analysis**

Since City Council’s acceptance of the Parks and recreation master plan, the philanthropic offer from Facebook has significantly accelerated the planning, design and anticipated delivery schedule of the MPCC (item 1 in Table 1 above.) As such, staff resources are heavily focused on delivering this project on schedule. In addition, other funded projects, including Willow Oaks Park improvements, Burgess Park playground renovation, the Bedwell Bayfront Park entrance improvements, and Sharon Park pathway reconstruction are underway as well.

However, the COVID-19 pandemic has impacted the capital planning, budgeting and delivery timelines for

the remaining Tier 1 parks projects following significant capital budget reductions in fiscal year 2020-21. The balance of the remaining Measure T funds could provide resources (up to \$5.5 million in additional funds) to deliver additional parks projects, as summarized in Table 2. Donations toward MPCC may also reduce the \$8.8 million maximum needed for MPCC.

Table 2: Measure T fund summary	
<b>Voter-approved bond capacity</b>	<b>\$38,000,000</b>
2002/12 Series	\$13,245,000
2009 Series	\$10,440,000
<b>Subtotal expended</b>	<b>\$23,685,000</b>
Amount remaining	\$14,315,000
Proposed maximum for MPCC	\$8,800,000
<b>Balance remaining for potential issuance</b>	<b>\$5,515,000</b>

Measure T funds expenditure timeline

Following guidance from the *California Debt Financing Guide* issued by the California Debt and Investment Advisory Commission (CDIAC), timely expenditure of bond proceeds from the date of issuance is important. Table 3 summarizes the expenditure requirements by year for the total remaining Measure T bonds (approximately \$14.3 million) and if only the maximum amount needed is issued for MPCC (\$8.8 million.) Staff does not anticipate concerns with the timeliness of expenditures for the \$8.8 million issued scenario, as the MPCC project is expected to be completed within two years which exceeds the expenditure timelines below. Staff has outlined options for City Council’s consideration for the \$14.3 million issued scenario below.

Table 3: Timeline for required Measure T expenditures			
Year	Expenditure guideline	\$8.8 million issued	\$14.3 million issued
1	10%	\$0.88 million	\$1.43 million
2	30%	\$2.64 million	\$4.29 million
3	60%	\$5.28 million	\$8.59 million
5	85%	\$7.48 million	\$12.17 million

Expected impacts to residents' tax bills

If the City Council decides to issue \$14.3 million in Measure T bonds to fund this and other Parks and Recreation master plan projects, property owners will begin paying approximately \$45 per 1 million assessed value in December 2022.

Table 4 summarizes the amount that a typical resident can anticipate paying as a result of these bonds. In addition, the measure caps the cost to property owners at \$140 per \$1 million of assessed value. Approximately 40 percent of the increase is anticipated to be paid by non-residential property owners.

Table 4: Anticipated tax implications	
Scenario	Tax amount per \$1 million assessed value
Current tax burden	\$80
\$8.8 million	+\$28 or \$108 total
\$14.3 million	+\$45 or \$125 total

Requested City Council direction

1. Should staff proceed with issuing Measure T bonds for the maximum amount needed for only MPCC (\$8.8 million); or another amount up to the total remaining amount (\$14.3 million) to deliver other parks projects as well?

The Measure T bond funds were approved by voters to invest in City park facilities. The Parks and Recreation and Bedwell Bayfront Park Master Plans identified clear needs for improvements and additional resources to complete the projects. It is more efficient to conduct one bond sale to provide the funds than to spread them out over two or more remaining events. However, staff has identified potential concerns with proceeding with the sale of the full amount, namely the ability to deliver additional projects on the timelines required by bond guidelines without either focusing on existing projects or providing additional resources to deliver the projects.

2. If issuing the total remaining amount (\$14.3 million), confirm prioritization of completing currently in-progress projects with Measure T funds.

As noted above, staff is focused on delivering the existing funded projects on their current schedules. These projects, their existing funding sources and estimated carry-over budgets are summarized in Table 5. As shown, the ongoing parks projects have budgets totaling approximately \$4.5 million from recreation in-lieu and general capital funds. In order to meet bond proceed expenditure requirements, staff recommends continuing to focus resources to complete these projects. As design and public engagement proceed on these projects, there may be opportunities to incrementally expand the scope of the projects to fully expend the Measure T funds. In particular, for Willow Oaks park improvements, staff has heard preliminary public feedback about opportunities to add additional seating and improve the basketball court area, and other opportunities may be identified as public engagement proceeds. In addition, the Burgess and Willow Oaks playground equipment replacements could be enhanced, such as that installed in 2019 at Nealon Park. While budget reductions in 2020-21 made these modifications otherwise out of reach, the use of Measure T may provide enhanced opportunities for such improvements.

If the existing funded projects are delivered with Measure T funds, currently appropriated resources may then be used to deliver additional parks projects (or other capital projects) in the future since those revenues are more flexible for delivery and timeline requirements. Staff would then program additional parks projects in future years of the capital improvement plan using the general capital and recreation in-lieu fee funds replaced by Measure T, following the Tier 1 Parks and Recreation Master Plan list (Table 1 above) to guide priorities.



Table 5: Currently funded (tier 1) parks capital projects			
Project name	Funding Source(s)	Est. Budgeted Amount	Amount Eligible for Measure T
Bedwell Bayfront Park entrance project	Grant/developer contribution/general capital	\$1,464,600	\$950,000
Willow Oaks Park improvements	Recreation in-lieu	\$898,900	\$898,900
Burgess and Willow Oaks Parks playground equipment (currently budgeted: design of both; construction of Willow Oaks)*	Recreation in-lieu	\$725,400	\$725,400
<b>Total</b>		<b>\$3,088,300</b>	<b>\$2,574,200</b>

\*The construction of both playgrounds could be funded with Measure T funds if they are expanded or improved. This would increase the budget needed for this project; for example, Nealon Park playground was approximately \$990,000 in 2019. Replacement of the equipment alone is considered maintenance and is not eligible expenditure under Measure T.

If City Council desires to proceed with new additional projects now by utilizing additional Measure T funds, additional resources (staff and/or consultant services) will be needed to deliver the projects. Staff would return to the City Council with a proposal for such resources at a later date, along with an assessment of capital projects that may be impacted.

**Next steps**

Following City Council direction, staff intends to return to the City Council to officially commence the Measure T bonds issuance process in the selected amount in order to maintain the schedule for MPCC on the September 14, 2021 City Council agenda. This schedule is critical to making the Measure T funds available on the necessary timeline for the MPCC project.

Staff plans to provide an informational update on the City Council’s direction at the August 25, 2021 Parks and Recreation Commission meeting.

**Impact on City Resources**

Significant future funding needs of \$20-40 million were identified in the Parks and recreation master plan for Tier 1 projects and \$11-13 million for projects in the Bedwell-Bayfront Park master plan. The use of additional Measure T funds would provide flexibility to program new future parks projects with currently budgeted recreation in-lieu fee funds and general capital projects. If no additional Measure T funds are desired to be used at this time, no impact on city resources is anticipated; however, delivery of future parks projects will be more constrained by available resources.

**Environmental Review**

This action is not a project within the meaning of the California Environmental Quality Act (CEQA) Guidelines §§ 15378 and 15061(b)(3) as it has no potential for resulting in any direct or indirect physical change in the environment. Individual projects within the capital improvement program would continue to be evaluated individually under CEQA as the projects proceed.

## Public Notice

Public notification was achieved by posting the agenda, with the agenda items being listed, at least 72 hours prior to the meeting.

## Attachments

- A. Hyperlink – October 17, 2017 City Council staff report including list of previously completed Measure T projects: [menlopark.org/DocumentCenter/View/15770/F1---Parks-and-Rec-Master-Plan-Consultant-Council-Staff-Report-20171017?bidId=](http://menlopark.org/DocumentCenter/View/15770/F1---Parks-and-Rec-Master-Plan-Consultant-Council-Staff-Report-20171017?bidId=)
- B. Hyperlink – Parks and recreation master plan: [menlopark.org/ArchiveCenter/ViewFile/Item/12107](http://menlopark.org/ArchiveCenter/ViewFile/Item/12107)
- C. Hyperlink – Bedwell Bayfront Park master plan: [menlopark.org/ArchiveCenter/ViewFile/Item/11956](http://menlopark.org/ArchiveCenter/ViewFile/Item/11956)

Report prepared by:  
Nikki Nagaya, Public Works Director

Report reviewed by:  
Justin Murphy, Deputy City Manager



# PARKS PROJECTS & MEASURE T FUNDS

August 17, 2021

## REQUESTED DIRECTION

- Should staff proceed with issuing Measure T bonds for only amount needed for MPCC (\$8.8 million) or the total remaining amount (\$14.3 million) to deliver other parks projects?

## MEASURE T OVERVIEW

- 2001 voter-approved measure for parks and recreation facilities
- Up to \$38 million
- Prior expenditures totaling \$23.7 million

### Measure T fund summary

Voter-approved bond capacity	\$38 million
Amount remaining	\$14.3 million
Proposed max for MPCC	\$8.8 million
Balance remaining for potential issuance	\$5.5 million

## PARKS PROJECTS

- Prior master plans have identified \$31-53 million in capital needs
  - Parks and Recreation Facilities Master Plan: 2019
  - Bedwell Bayfront Park Master Plan: 2017
- Funding sources:
  - General capital funds
  - Recreation in-lieu fees from residential development
  - Measure T

### Expenditure requirement at 3 years: 60%

\$8.8 million issued scenario	\$5.28 million
\$14.3 million issued scenario	\$8.59 million

## ANTICIPATED TAX IMPLICATIONS

Scenario	Per \$1 million assessed value
Current tax burden	\$80
\$8.8 million issued scenario	+ \$28 or \$108 total
\$14.3 million issued scenario	+ \$45 or \$125 total

- Increase expected in December 2022
- 40% of increase is anticipated to be paid by non-residential property owners
- Measure caps cost at \$140 per \$1 million assessed value

## REQUESTED DIRECTION

- Should staff proceed with issuing Measure T bonds for only amount needed for MPCC (\$8.8 million) or the total remaining amount (\$14.3 million) to deliver other parks projects?
- Confirm prioritization of projects



## NEXT STEPS

- Return September 14 to seek authorization by the City Council to commence bond issuance
- Continue progress on MPCC
- Update to the Parks and Recreation Commission on August 25



**THANK YOU**



## STAFF REPORT

**City Council**

**Meeting Date:**

**8/17/2021**

**Staff Report Number:**

**21-146-CC**

**Consent Calendar:**

**Receive Finance and Audit Committee's recommendation and adopt Resolution No. 6651 approving the 2021-22 investment policy for the City and the former Community Development Agency of Menlo Park**

### Recommendation

Receive Finance and Audit Committee's (FAC) recommendation and adopt Resolution No. 6651 to approve the 2021-22 investment policy for the City and the former Community Development Agency of Menlo Park

### Policy Issues

The investment policy provides guidelines for investing City and former Agency funds in accordance with State of California Government Code Section 53601 et seq.

### Background

The investment of funds by a California local agency, including the types of securities in which an agency may invest, is governed by the California Government Code. The law requires that the legislative body of each agency adopt an investment policy, which may add further limitations than those established by the State. In addition, an agency's investment policy must be reviewed annually, and any changes must be adopted at a public meeting. The City of Menlo Park has had such a policy in place since 1990. The investment policy was last reviewed and updated by the City Council August 10, 2020.

Annual adoption of the City's investment policy provides an opportunity to regularly review the policy to ensure its consistency with the overall objectives of safety, liquidity and yield, as well as its relevance to current law and economic trends. Early in each fiscal year, the City's investment adviser (Insight Investment) reviews the policy to ensure it is kept up to date and in compliance with applicable State statutes. Insight also makes recommendations for strategic changes to the investment policy to position the City's portfolio to maximize yield while maintaining safety and liquidity.

The annual review of the City's investment policy provides the opportunity to make modifications to reflect changes in the investment environment. The types of modifications will vary but are often focused on providing greater diversification to maintain a safe and liquid investment portfolio. Further, the annual review is also a good time to clarify certain terms, remove ambiguity in the policy language, and better reflect changes in current market trading technologies.

### Analysis

At their August 2, 2021 special meeting, the FAC reviewed City staff's recommended edits (Attachment A)

to the City's investment policy previously adopted by City Council August 10, 2020. The FAC approved a motion for City Council to approve the 2021-22 investment policy for the City and the former Community Development Agency of Menlo Park, as recommended by City staff. The motion passed with a vote of 5-1, (City Councilmember Mueller absent.)

### **Public Notice**

Public notification was achieved by posting the agenda, with the agenda items being listed, at least 72 hours prior to the meeting.

### **Attachments**

- A. Redline 2021-22 investment policy for the City and the former Community Development Agency of Menlo Park
- B. Resolution No. 6651

Report prepared by:  
Nick Pegueros, Assistant City Manager

# Investment Policy

City Council Procedure #CC-~~20-020~~21-020

Adopted August ~~11, 2020~~17, 2021



## Purpose

The City of Menlo Park (the “City”), incorporated in 1927, is located between San Francisco and Oakland on the North, and San Jose on the South. The city is governed by five members elected by district to City Council. ~~Effective November 2018, the city began the transition from at large elections to by district elections. Three of the five City Councilmembers were elected by district in November 2018. Two of the five City Councilmembers were elected at large in November 2016 to four-year terms expiring in 2020. The transition to by district elections will be complete in November 2020.~~

The City Council has adopted this Investment Policy (the “Policy”) in order to establish the investment scope, objectives, delegation of authority, standards of prudence, reporting requirements, internal controls, eligible investments and transactions, diversification requirements, risk tolerance, and safekeeping and custodial procedures for the investment of the unexpended funds of the city. All such investments will be made in accordance with the Policy and with applicable sections of the California Government Code.

This Policy was endorsed and adopted by the City Council of the City of Menlo Park on the ~~twentieth~~seventeenth of August ~~2019~~2021. It replaces any previous investment policy or investment procedures of the city.

## Scope

The provisions of this Policy shall apply to all financial assets of the city and the Community Development Agency of Menlo Park as accounted for in the city’s comprehensive annual financial report, with the exception of bond proceeds, which shall be governed by the provisions of the related bond indentures or resolutions.

All cash shall be pooled for investment purposes. The investment income derived from the pooled investment account shall be allocated to the contributing funds based upon the proportion of the respective average balances relative to the total pooled balance in the investment portfolio. Investment income shall be distributed to the individual funds on a quarterly basis.

## Objectives

The city’s funds shall be invested in accordance with all applicable municipal codes and resolutions, California statutes, and federal regulations, and in a manner designed to accomplish the following objectives, which are listed in priority order:

1. Preservation of capital and protection of investment principal.
2. Maintenance of sufficient liquidity to meet anticipated cash flows.
3. Attainment of a market value rate of return.

Diversification to avoid incurring unreasonable market risks.

## Delegation of authority

The management responsibility for the city’s investment program is delegated annually by the City Council to the chief financial officer (the “CFO”) pursuant to California Government Code Section 53607. The City’s ~~administrative services Director~~assistant city manager serves as the CFO. In the absence of the CFO, the finance and budget manager is authorized to conduct investment transactions. The CFO may delegate the authority to conduct investment transactions and to manage the operation of the investment portfolio to other specifically authorized staff members. The CFO shall maintain a list of persons authorized to transact securities business for the city. No person may engage in an investment transaction except as expressly provided under the terms of this policy.

The CFO shall develop written administrative procedures and internal controls, consistent with this policy, for the operation of the city’s investment program. Such procedures shall be designed to prevent losses of public funds arising from fraud, employee error, misrepresentation by third parties, or imprudent actions by employees of the city.

The city may engage the support services of outside investment advisors in regard to its investment program, so long as it can be clearly demonstrated that these services produce a net financial advantage or necessary financial protection of the city’s financial resources.

## Investment Policy

City Council Procedure #CC-20-02021-020

Adopted August 11, 2020/17, 2021

2

### Prudence

The standard of prudence to be used for managing the city's investments shall be California Government Code Section 53600.3, the prudent investor standard which states, "When investing, reinvesting, purchasing, acquiring, exchanging, selling, or managing public funds, a trustee shall act with care, skill, prudence, and diligence under the circumstances then prevailing, including, but not limited to, the general economic conditions and the anticipated needs of the agency, that a prudent person acting in a like capacity and familiarity with those matters would use in the conduct of funds of a like character and with like aims, to safeguard the principal and maintain the liquidity needs of the agency."

The city's overall investment program shall be designed and managed with a degree of professionalism that is worthy of the public trust. The city recognizes that no investment is totally without risk and that the investment activities of the city are a matter of public record. Accordingly, the city recognizes that occasional measured losses may occur in a diversified portfolio and shall be considered within the context of the overall portfolio's return, provided that adequate diversification has been implemented and that the sale of a security is in the best long-term interest of the city.

The CFO and authorized investment personnel acting in accordance with written procedures and exercising due diligence shall be relieved of personal responsibility for an individual security's credit risk or market price changes, provided that the deviations from expectations are reported in a timely fashion to the City Council and appropriate action is taken to control adverse developments.

### Ethic and conflicts of interest

Elected officials and employees involved in the investment process shall refrain from personal business activity that could conflict with proper execution of the investment program or could impair or create the appearance of an impairment of their ability to make impartial investment decisions. Employees and investment officials shall disclose to the city manager any business interests they have in financial institutions that conduct business with the city and they shall subordinate their personal investment transactions to those of the city. In addition, the city manager, the assistant city manager and the administrative services director shall file a Statement of Economic Interests each year pursuant to California Government Code Section 87203 and regulations of the Fair Political Practices Commission.

### Authorized securities and transactions

All investments and deposits of the city shall be made in accordance with California Government Code Sections 16429.1, 53600-53609 and 53630-53686, except that, pursuant to California Government Code Section 5903(e), proceeds of bonds and any moneys set aside or pledged to secure payment of the bonds may be invested in securities or obligations described in the ordinance, resolution, indenture, agreement, or other instrument providing for the issuance of the bonds.

Any revisions or extensions of these code sections will be assumed to be part of this policy immediately upon being enacted. However, in the event that amendments to these sections conflict with this policy or past city investment practices, the city may delay adherence to the new requirements when it is deemed in the best interest of the city to do so. In such instances, after consultation with the city's attorney, the CFO will present a recommended course of action to the City Council for approval.

The city has further restricted the eligible types of securities and transactions as follows:

1. United States treasury bills, notes, bonds, or strips with a final maturity not exceeding five years from the date of trade settlement.
2. Federal agency debentures, federal agency mortgage-backed securities, and mortgage-backed securities with a final maturity not exceeding five years from the date of trade settlement.
3. Federal instrumentality (government-sponsored enterprise) debentures, discount notes, callable securities, step-up securities, and mortgage-backed securities with a final maturity not exceeding five years from the date of trade settlement. Subordinated debt may not be purchased.
4. Medium-term notes issued by corporations organized and operating within the United States or by depository institutions licensed by the United States or any state and operating within the United States. Medium-term notes shall have a final maturity not exceeding five years from the date of trade settlement and shall be rated at least "A" or the equivalent by a nationally recognized statistical ratings organization (NRSRO), at the time of purchase.
5. Negotiable certificates of deposit with a maturity not exceeding five years from the date of trade settlement, in state or nationally chartered banks or savings banks that are insured by the FDIC, subject to the limitations of California Government Code Section 53638. Certificates of Deposits may be purchased only from financial institutions that meet the credit criteria set forth in the section of this Investment Policy, "Selection of Banks and Savings Banks." Depending on their maturity, Negotiable Certificates of Deposit shall have a short-term

## Investment Policy

City Council Procedure #CC-~~20-020~~21-020

Adopted August ~~11, 2020~~17, 2021

3

- rating of at least A-1+ or the equivalent by a NRSRO at the time of purchase.
6. Non-negotiable certificates of deposit and savings deposits with a maturity not exceeding five years from the date of trade settlement, in FDIC insured state or nationally chartered banks or savings banks that qualify as a depository of public funds in the State of California as defined in California Government Code Section 53630.5. Deposits exceeding the FDIC insured amount shall be secured pursuant to California Government Code Section 53652.
  7. Municipal and State obligations:
    - A. Municipal bonds with a final maturity not exceeding five years from the date of trade settlement. Such bonds include registered treasury notes or bonds of any of the 50 United States and bonds payable solely out of the revenues from a revenue-producing property owned, controlled, or operated by a state or by a department, board, agency, or authority of any of the states. Such obligations must be rated at least "A", or the equivalent, by a NRSRO at the time of purchase.
    - B. In addition, bonds, notes, warrants, or other evidences of indebtedness of any local agency in California, include bonds payable solely out of the revenues from a revenue-producing property owned, controlled, or operated by the local agency, or by a department, board, agency, or authority of the local agency. Such obligations must be rated at least "A", or the equivalent, by a NRSRO at the time of purchase.
  8. Prime commercial paper with a maturity not exceeding 270 days from the date of trade settlement with the highest ranking or of the highest letter and number rating as provided for by a NRSRO. The entity that issues the commercial paper shall meet all of the following conditions in either sub-paragraph A. or sub-paragraph B. below:
    - A. The entity shall (1) be organized and operating in the United States as a general corporation, (2) have total assets in excess of \$500 million, and (3)
    - B. The entity shall (1) be organized within the United States as a special purpose corporation, trust, or limited liability company, (2) have program-wide credit enhancements, including, but not limited to, over collateralization, letters of credit or surety bond, and (3) have commercial paper that is rated at least "A-1" or the equivalent or higher by a NRSRO.
  9. Eligible banker's acceptances with a maturity not exceeding 180 days from the date of trade settlement, issued by a national bank with combined capital and surplus of at least \$250 million, whose deposits are insured by the FDIC, and whose senior long-term debt is rated at least "A" or the equivalent by a NRSRO at the time of purchase.
  10. Repurchase agreements with a final termination date not exceeding 30 days collateralized by the U.S. Treasury obligations, federal agency securities, or federal instrumentality securities listed in items #1 through #3 above, with the maturity of the collateral not exceeding five years. For the purpose of this section, the term collateral shall mean purchased securities under the terms of the city's approved Master Repurchase Agreement. The purchased securities shall have a minimum market value including accrued interest of 102% of the dollar value of the funds borrowed. Collateral shall be held in the city's custodian bank, as safekeeping agent, and the market value of the collateral securities shall be marked-to-the-market daily. Repurchase agreements shall be entered into only with banks and with broker/dealers who are recognized as Primary Dealers with the Federal Reserve Bank of New York, or with firms that have a primary dealer within their holding company structure. Repurchase agreement counterparties shall execute a city approved Master Repurchase Agreement with the city. The CFO shall maintain a copy of the city's approved Master Repurchase Agreement along with a list of the banks and broker/dealers who have executed same.
  11. State of California's Local Agency Investment Fund (LAIF), pursuant to California Government Code Section 16429.1.
  12. Money market funds registered under the Investment Company Act of 1940 which (1) are "no-load" (meaning no commission or fee shall be charged on purchases or sales of shares); (2) have a constant daily net asset value per share of \$1.00; (3) invest only in the securities and obligations authorized in this Policy and (4) have a rating of at least "AAA" or the equivalent by at least two NRSROs.

Securities that have been downgraded to a level that is below the minimum ratings described herein may be sold or held at the city's discretion.

It is the intent of the city that the foregoing list of authorized securities and transactions be strictly interpreted. Any deviation from this list must be preapproved by resolution of the City Council.

### Investment diversification

The city shall diversify its investments to avoid incurring unreasonable risks inherent in over-investing in specific instruments, individual financial institutions or maturities. Nevertheless, the asset allocation in the investment portfolio should be flexible depending upon the outlook for the economy, the securities markets, and the city's anticipated cash flow needs.

## Investment Policy

City Council Procedure #CC-20-02021-020

Adopted August 11, 2020 17, 2021

4

Securities shall not exceed the following maximum limits as a percentage of the total portfolio:

Type of security	Maximum percentage of the total portfolio
U.S. Treasury obligations	100%
Federal agency securities	100%†
Federal instrumentality securities†	100% †
Repurchase agreements	100%
Local government investment pools	100%
Aggregate amount of Certificates of deposit, negotiable and non-negotiable	25%
Aggregate amount of prime commercial paper*	25%
Aggregate amount of money market funds *	20%
Aggregate amount of municipal bonds*	30%
Aggregate amount of eligible banker's acceptances*	15%
Aggregate amount of medium-term notes*	30%

† No more than 20% of the city's total portfolio shall be invested in mortgage-backed securities.

\*No more than 5% of the city's total portfolio shall be invested in any one issuer/financial institution and/or its affiliates.

### Portfolio maturities and liquidity

To the extent possible, investments shall be matched with anticipated cash flow requirements and known future liabilities. The city will not invest in securities maturing more than five years from the date of trade settlement unless the City Council has, by resolution, granted authority to make such an investment at least three months prior to the date of investment. The sole maturity distribution range shall be from zero to five years from the date of trade settlement.

### Selection of broker/dealers

The CFO shall maintain a list of broker/dealers approved for investment purposes, and it shall be the policy of the city to purchase securities only from those authorized firms. To be eligible, a firm must be licensed by the State of California as a broker/dealer as defined in Section 25004 of the California Corporations Code.

The city may engage the services of investment advisory firms to assist in the management of the portfolio and investment advisors may utilize their own list of approved Broker/Dealers. The list of approved firms shall be provided to the city on an annual basis or upon request.

In the event that an external investment advisory firm is not used in the process of recommending a particular transaction, each authorized broker/dealer shall be required to submit and annually update a city approved Broker/Dealer Information Request form which includes the firm's most recent financial statements. The CFO shall maintain a list of the broker/dealers that have been approved by the city, along with each firm's most recent broker/dealer information request form. The city may purchase commercial paper from direct issuers even though they are not on the approved broker/dealer list as long as they meet the criteria outlined in Item 8 of the authorized securities and transactions section of this Policy.

### Competitive transactions

Each investment transaction shall be competitively transacted with authorized broker/dealers. At least three broker/dealers shall be contacted for each transaction and their bid and offering prices shall be recorded.

If the city is offered a security for which there is no other readily available competitive offering, the CFO will then document quotations for comparable or alternative securities.

### Selection of banks and savings banks

The CFO shall maintain a list of authorized banks and savings banks that are approved to provide banking services for the city. To be eligible to provide banking services, a financial institution shall qualify as a depository of public funds in the State of California as defined in California Government Code Section 53630.5 and must be a member of the FDIC. The city shall utilize SNL Financial Bank Insight ratings to perform credit analyses on banks seeking authorization. The analysis shall include a composite rating and individual ratings of liquidity, asset quality, profitability and capital adequacy. Annually, the CFO shall review the most recent credit rating analysis reports.



## Investment Policy

City Council Procedure #CC-~~20-020~~21-020

Adopted August ~~11, 2020~~17, 2021

5

performed for each approved bank. Banks that in the judgment of the CFO no longer offer adequate safety to the city shall be removed from the city's list of authorized banks. Banks failing to meet the criteria outlined above, or in the judgment of the CFO no longer offer adequate safety to the city, will be removed from the list. The CFO shall maintain a file of the most recent credit rating analysis reports performed for each approved bank. Credit analysis shall be performed on a semi-annual basis.

### Safekeeping and custody

The CFO shall select one or more financial institutions to provide safekeeping and custodial services for the city, in accordance with the provisions of Section 53608 of the California Government Code. Custodian banks will be selected on the basis of their ability to provide services for the city's account and the competitive pricing of their safekeeping related services. The CFO shall maintain a file of the credit rating analysis reports performed semi-annually for each approved financial institution. A Safekeeping Agreement approved by the city shall be executed with each custodian bank prior to utilizing that bank's safekeeping services.

The purchase and sale of securities and repurchase agreement transactions shall be settled on a delivery versus payment basis. All securities shall be perfected in the name of the city. Sufficient evidence to title shall be consistent with modern investment, banking and commercial practices.

All investment securities purchased by the city will be delivered by book entry and will be held in third-party safekeeping by a city approved custodian bank, or its Depository Trust Company (DTC) participant account.

### Portfolio performance

The investment portfolio shall be designed to attain a market rate of return throughout budgetary and economic cycles, taking into account prevailing market conditions, risk constraints for eligible securities, and cash flow requirements. The performance of the city's investments shall be compared to the average yield on the U.S. Treasury security that most closely corresponds to the portfolio's actual weighted average effective maturity. When comparing the performance of the city's portfolio, its rate of return will be computed net of all fees and expenses.

### Portfolio review and reporting

Credit criteria and maximum percentages listed in this section refer to the credit of the issuing organization and/or maturity at the time the security is purchased. The city may, from time to time, be invested in a security whose rating is downgraded below the minimum ratings set forth in this policy. In the event a rating drops below the minimum allowed rating category for that given investment type, the administrative services director shall notify the city manager and/or designee and recommend a plan of action. Appropriate documentation of such a review, along with the recommended action and final decision shall be retained for audit.

Quarterly, the CFO shall submit to the City Council a report of the investment earnings and performance results of the city's investment portfolio. The report shall include the following information:

1. Investment type, issuer, date of maturity, par value and dollar amount invested in all securities, and investments and monies held by the city;
2. A description of the funds, investments and programs;
3. A market value as of the date of the report (or the most recent valuation as to assets not valued monthly) and the source of the valuation;
4. A statement of compliance with this Investment Policy or an explanation for not-compliance; and
5. A statement of the ability to meet expenditure requirements for six months, as well as an explanation of why money will not be available if that is the case.

### Policy review

This investment policy shall be adopted by resolution of the City Council annually. It shall be reviewed at least annually to ensure its consistency with the overall objectives of preservation of principal, liquidity, yield and diversification and its relevance to current law and economic trends. Any amendments to the Policy shall be reviewed by the City's Finance and /Audit Committee prior to being forwarded to the City Council for approval.

**Investment Policy**City Council Procedure #~~CC-20-020~~[21-020](#)

6

Adopted August ~~11, 2020~~[17, 2021](#)

<b>Procedure history</b>		
Action	Date	Notes
Procedure adoption	January 14, 1997	Resolution No. 4784
Procedure adoption	February 17, 1998	Resolution No. 4871
Procedure adoption	February 2, 1999	Resolution No. 5064
Procedure adoption	February 13, 2001	Resolution No. 5283
Procedure adoption	May 9, 2000	Adopted by minute order
Procedure adoption	February 5, 2002	Resolution No. 5362
Procedure adoption	June 24, 2003	Resolution No. 5457
Procedure adoption	June 20, 2004	Resolution No. 5545
Procedure adoption	August 15, 2005	Resolution No. 5616
Procedure adoption	July 25, 2006	Resolution No. 5960
Procedure adoption	July 31, 2007	Resolution No. 5759
Procedure adoption	September 23, 2008	Resolution No. 5825
Procedure adoption	September 1, 2009	Resolution No. 5886
Procedure adoption	August 31, 2010	Resolution No. 5957
Procedure adoption	September 27, 2011	Resolution No. 6028
Procedure adoption	September 18, 2012	Resolution No. 6103
Procedure adoption	October 15, 2013	Resolution No. 6171
Procedure adoption	August 19, 2014	Resolution No. 6221
Procedure adoption	August 25, 2015	Resolution No. 6286
Procedure adoption	September 13, 2016	Resolution No. 6343
Procedure adoption	August 20, 2019	Adopted by minute order
Procedure adoption	August 11, 2020	Adopted by minute order
<a href="#">Procedure adoption</a>	<a href="#">August 17, 2021</a>	<a href="#">Resolution No. 6651</a>

**RESOLUTION NO. 6651**

**RESOLUTION OF THE CITY COUNCIL OF THE CITY OF MENLO PARK  
ADOPTING THE REVISED INVESTMENT POLICY (EXHIBIT A) FOR THE  
CITY AND FORMER COMMUNITY DEVELOPMENT AGENCY TO BECOME  
EFFECTIVE IMMEDIATELY**

The City of Menlo Park, acting by and through its City Council, having considered and been fully advised in the matter and good cause appearing therefore.

BE IT AND IT IS HEREBY RESOLVED by the City Council of the City of Menlo Park that the City Council does hereby adopt Exhibit A as the revised investment policy for the City and former Community Development Agency to become effective immediately.

I, Judi A. Herren, City Clerk of Menlo Park, do hereby certify that the above and foregoing City Council Resolution was duly and regularly passed and adopted at a meeting by said City Council on the seventeenth day of August, 2021, by the following votes:

AYES:

NOES:

ABSENT:

ABSTAIN:

IN WITNESS WHEREOF, I have hereunto set my hand and affixed the Official Seal of said City on this seventeenth day of August, 2021.

---

Judi A. Herren, City Clerk

**Investment Policy**

City Council Procedure #CC-21-020

Adopted August 17, 2021

**Purpose**

The City of Menlo Park (the “City”), incorporated in 1927, is located between San Francisco and Oakland on the North, and San Jose on the South. The city is governed by five members elected by district to City Council.

The City Council has adopted this Investment Policy (the “Policy”) in order to establish the investment scope, objectives, delegation of authority, standards of prudence, reporting requirements, internal controls, eligible investments and transactions, diversification requirements, risk tolerance, and safekeeping and custodial procedures for the investment of the unexpended funds of the city. All such investments will be made in accordance with the Policy and with applicable sections of the California Government Code.

This Policy was endorsed and adopted by the City Council of the City of Menlo Park on the seventeenth of August 2021. It replaces any previous investment policy or investment procedures of the city.

**Scope**

The provisions of this Policy shall apply to all financial assets of the city and the Community Development Agency of Menlo Park as accounted for in the city’s comprehensive annual financial report, with the exception of bond proceeds, which shall be governed by the provisions of the related bond indentures or resolutions.

All cash shall be pooled for investment purposes. The investment income derived from the pooled investment account shall be allocated to the contributing funds based upon the proportion of the respective average balances relative to the total pooled balance in the investment portfolio. Investment income shall be distributed to the individual funds on a quarterly basis.

**Objectives**

The city’s funds shall be invested in accordance with all applicable municipal codes and resolutions, California statutes, and federal regulations, and in a manner designed to accomplish the following objectives, which are listed in priority order:

1. Preservation of capital and protection of investment principal.
2. Maintenance of sufficient liquidity to meet anticipated cash flows.
3. Attainment of a market value rate of return.

Diversification to avoid incurring unreasonable market risks.

**Delegation of authority**

The management responsibility for the city’s investment program is delegated annually by the City Council to the chief financial officer (the “CFO”) pursuant to California Government Code Section 53607. The City’s assistant city manager serves as the CFO. In the absence of the CFO, the finance and budget manager is authorized to conduct investment transactions. The CFO may delegate the authority to conduct investment transactions and to manage the operation of the investment portfolio to other specifically authorized staff members. The CFO shall maintain a list of persons authorized to transact securities business for the city. No person may engage in an investment transaction except as expressly provided under the terms of this policy.

The CFO shall develop written administrative procedures and internal controls, consistent with this policy, for the operation of the city’s investment program. Such procedures shall be designed to prevent losses of public funds arising from fraud, employee error, misrepresentation by third parties, or imprudent actions by employees of the city.

The city may engage the support services of outside investment advisors in regard to its investment program, so long as it can be clearly demonstrated that these services produce a net financial advantage or necessary financial protection of the city’s financial resources.

**Investment Policy**

City Council Procedure #CC-21-020

Adopted August 17, 2021

**Prudence**

The standard of prudence to be used for managing the city's investments shall be California Government Code Section 53600.3, the prudent investor standard which states, "When investing, reinvesting, purchasing, acquiring, exchanging, selling, or managing public funds, a trustee shall act with care, skill, prudence, and diligence under the circumstances then prevailing, including, but not limited to, the general economic conditions and the anticipated needs of the agency, that a prudent person acting in a like capacity and familiarity with those matters would use in the conduct of funds of a like character and with like aims, to safeguard the principal and maintain the liquidity needs of the agency."

The city's overall investment program shall be designed and managed with a degree of professionalism that is worthy of the public trust. The city recognizes that no investment is totally without risk and that the investment activities of the city are a matter of public record. Accordingly, the city recognizes that occasional measured losses may occur in a diversified portfolio and shall be considered within the context of the overall portfolio's return, provided that adequate diversification has been implemented and that the sale of a security is in the best long-term interest of the city.

The CFO and authorized investment personnel acting in accordance with written procedures and exercising due diligence shall be relieved of personal responsibility for an individual security's credit risk or market price changes, provided that the deviations from expectations are reported in a timely fashion to the City Council and appropriate action is taken to control adverse developments.

**Ethic and conflicts of interest**

Elected officials and employees involved in the investment process shall refrain from personal business activity that could conflict with proper execution of the investment program or could impair or create the appearance of an impairment of their ability to make impartial investment decisions. Employees and investment officials shall disclose to the city manager any business interests they have in financial institutions that conduct business with the city and they shall subordinate their personal investment transactions to those of the city. In addition, the city manager, the assistant city manager and the administrative services director shall file a Statement of Economic Interests each year pursuant to California Government Code Section 87203 and regulations of the Fair Political Practices Commission.

**Authorized securities and transactions**

All investments and deposits of the city shall be made in accordance with California Government Code Sections 16429.1, 53600-53609 and 53630-53686, except that, pursuant to California Government Code Section 5903(e), proceeds of bonds and any moneys set aside or pledged to secure payment of the bonds may be invested in securities or obligations described in the ordinance, resolution, indenture, agreement, or other instrument providing for the issuance of the bonds.

Any revisions or extensions of these code sections will be assumed to be part of this policy immediately upon being enacted. However, in the event that amendments to these sections conflict with this policy or past city investment practices, the city may delay adherence to the new requirements when it is deemed in the best interest of the city to do so. In such instances, after consultation with the city's attorney, the CFO will present a recommended course of action to the City Council for approval.

The city has further restricted the eligible types of securities and transactions as follows:

1. United States treasury bills, notes, bonds, or strips with a final maturity not exceeding five years from the date of trade settlement.
2. Federal agency debentures, federal agency mortgage-backed securities, and mortgage-backed securities with a final maturity not exceeding five years from the date of trade settlement.
3. Federal instrumentality (government-sponsored enterprise) debentures, discount notes, callable securities, step-up securities, and mortgage-backed securities with a final maturity not exceeding five years from the date of trade settlement. Subordinated debt may not be purchased.
4. Medium-term notes issued by corporations organized and operating within the United States or by depository institutions licensed by the United States or any state and operating within the United States. Medium-term notes shall have a final maturity not exceeding five years from the date of trade settlement and shall be rated at least "A" or the equivalent by a nationally recognized statistical ratings organization (NRSRO), at the time of purchase.
5. Negotiable certificates of deposit with a maturity not exceeding five years from the date of trade settlement, in state or nationally chartered banks or savings banks that are insured by the FDIC, subject to the limitations of California Government Code Section 53638. Certificates of Deposits may be purchased only from financial institutions that meet the credit criteria set forth in the section of this Investment Policy, "Selection of Banks and Savings Banks." Depending on their maturity, Negotiable Certificates of Deposit shall have a short-term

**Investment Policy**

City Council Procedure #CC-21-020

Adopted August 17, 2021

3

- rating of at least A-1+ or the equivalent by a NRSRO at the time of purchase.
6. Non-negotiable certificates of deposit and savings deposits with a maturity not exceeding five years from the date of trade settlement, in FDIC insured state or nationally chartered banks or savings banks that qualify as a depository of public funds in the State of California as defined in California Government Code Section 53630.5. Deposits exceeding the FDIC insured amount shall be secured pursuant to California Government Code Section 53652.
  7. Municipal and State obligations:
    - A. Municipal bonds with a final maturity not exceeding five years from the date of trade settlement. Such bonds include registered treasury notes or bonds of any of the 50 United States and bonds payable solely out of the revenues from a revenue-producing property owned, controlled, or operated by a state or by a department, board, agency, or authority of any of the states. Such obligations must be rated at least "A", or the equivalent, by a NRSRO at the time of purchase.
    - B. In addition, bonds, notes, warrants, or other evidences of indebtedness of any local agency in California, include bonds payable solely out of the revenues from a revenue-producing property owned, controlled, or operated by the local agency, or by a department, board, agency, or authority of the local agency. Such obligations must be rated at least "A", or the equivalent, by a NRSRO at the time of purchase.
  8. Prime commercial paper with a maturity not exceeding 270 days from the date of trade settlement with the highest ranking or of the highest letter and number rating as provided for by a NRSRO. The entity that issues the commercial paper shall meet all of the following conditions in either sub-paragraph A. or sub-paragraph B. below:
    - A. The entity shall (1) be organized and operating in the United States as a general corporation, (2) have total assets in excess of \$500 million, and (3)
    - B. The entity shall (1) be organized within the United States as a special purpose corporation, trust, or limited liability company, (2) have program-wide credit enhancements, including, but not limited to, over collateralization, letters of credit or surety bond, and (3) have commercial paper that is rated at least "A-1" or the equivalent or higher by a NRSRO.
  9. Eligible banker's acceptances with a maturity not exceeding 180 days from the date of trade settlement, issued by a national bank with combined capital and surplus of at least \$250 million, whose deposits are insured by the FDIC, and whose senior long-term debt is rated at least "A" or the equivalent by a NRSRO at the time of purchase.
  10. Repurchase agreements with a final termination date not exceeding 30 days collateralized by the U.S. Treasury obligations, federal agency securities, or federal instrumentality securities listed in items #1 through #3 above, with the maturity of the collateral not exceeding five years. For the purpose of this section, the term collateral shall mean purchased securities under the terms of the city's approved Master Repurchase Agreement. The purchased securities shall have a minimum market value including accrued interest of 102% of the dollar value of the funds borrowed. Collateral shall be held in the city's custodian bank, as safekeeping agent, and the market value of the collateral securities shall be marked-to-the-market daily. Repurchase agreements shall be entered into only with banks and with broker/dealers who are recognized as Primary Dealers with the Federal Reserve Bank of New York, or with firms that have a primary dealer within their holding company structure. Repurchase agreement counterparties shall execute a city approved Master Repurchase Agreement with the city. The CFO shall maintain a copy of the city's approved Master Repurchase Agreement along with a list of the banks and broker/dealers who have executed same.
  11. State of California's Local Agency Investment Fund (LAIF), pursuant to California Government Code Section 16429.1.
  12. Money market funds registered under the Investment Company Act of 1940 which (1) are "no-load" (meaning no commission or fee shall be charged on purchases or sales of shares); (2) have a constant daily net asset value per share of \$1.00; (3) invest only in the securities and obligations authorized in this Policy and (4) have a rating of at least "AAA" or the equivalent by at least two NRSROs.

Securities that have been downgraded to a level that is below the minimum ratings described herein may be sold or held at the city's discretion.

It is the intent of the city that the foregoing list of authorized securities and transactions be strictly interpreted. Any deviation from this list must be preapproved by resolution of the City Council.

**Investment diversification**

The city shall diversify its investments to avoid incurring unreasonable risks inherent in over-investing in specific instruments, individual financial institutions or maturities. Nevertheless, the asset allocation in the investment portfolio should be flexible depending upon the outlook for the economy, the securities markets, and the city's anticipated cash flow needs.

**Investment Policy**

City Council Procedure #CC-21-020

Adopted August 17, 2021

Securities shall not exceed the following maximum limits as a percentage of the total portfolio:

<b>Type of security</b>	<b>Maximum percentage of the total portfolio</b>
U.S. Treasury obligations	100%
Federal agency securities	100%†
Federal instrumentality securities†	100% †
Repurchase agreements	100%
Local government investment pools	100%
Aggregate amount of Certificates of deposit, negotiable and non-negotiable	25%
Aggregate amount of prime commercial paper*	25%
Aggregate amount of money market funds *	20%
Aggregate amount of municipal bonds*	30%
Aggregate amount of eligible banker's acceptances*	15%
Aggregate amount of medium-term notes*	30%

† No more than 20% of the city's total portfolio shall be invested in mortgage-backed securities.

\*No more than 5% of the city's total portfolio shall be invested in any one issuer/financial institution and/or its affiliates.

**Portfolio maturities and liquidity**

To the extent possible, investments shall be matched with anticipated cash flow requirements and known future liabilities. The city will not invest in securities maturing more than five years from the date of trade settlement unless the City Council has, by resolution, granted authority to make such an investment at least three months prior to the date of investment. The sole maturity distribution range shall be from zero to five years from the date of trade settlement.

**Selection of broker/dealers**

The CFO shall maintain a list of broker/dealers approved for investment purposes, and it shall be the policy of the city to purchase securities only from those authorized firms. To be eligible, a firm must be licensed by the State of California as a broker/dealer as defined in Section 25004 of the California Corporations Code.

The city may engage the services of investment advisory firms to assist in the management of the portfolio and investment advisors may utilize their own list of approved Broker/Dealers. The list of approved firms shall be provided to the city on an annual basis or upon request.

In the event that an external investment advisory firm is not used in the process of recommending a particular transaction, each authorized broker/dealer shall be required to submit and annually update a city approved Broker/Dealer Information Request form which includes the firm's most recent financial statements. The CFO shall maintain a list of the broker/dealers that have been approved by the city, along with each firm's most recent broker/dealer information request form. The city may purchase commercial paper from direct issuers even though they are not on the approved broker/dealer list as long as they meet the criteria outlined in Item 8 of the authorized securities and transactions section of this Policy.

**Competitive transactions**

Each investment transaction shall be competitively transacted with authorized broker/dealers. At least three broker/dealers shall be contacted for each transaction and their bid and offering prices shall be recorded.

If the city is offered a security for which there is no other readily available competitive offering, the CFO will then document quotations for comparable or alternative securities.

**Selection of banks and savings banks**

The CFO shall maintain a list of authorized banks and savings banks that are approved to provide banking services for the city. To be eligible to provide banking services, a financial institution shall qualify as a depository of public funds in the State of California as defined in California Government Code Section 53630.5 and must be a member of the FDIC. The city shall utilize SNL Financial Bank Insight ratings to perform credit analyses on banks seeking authorization. The analysis shall include a composite rating and individual ratings of liquidity, asset quality, profitability and capital adequacy. Annually, the CFO shall review the most recent credit rating analysis reports

**Investment Policy**

City Council Procedure #CC-21-020

Adopted August 17, 2021

5

performed for each approved bank. Banks that in the judgment of the CFO no longer offer adequate safety to the city shall be removed from the city's list of authorized banks. Banks failing to meet the criteria outlined above, or in the judgment of the CFO no longer offer adequate safety to the city, will be removed from the list. The CFO shall maintain a file of the most recent credit rating analysis reports performed for each approved bank. Credit analysis shall be performed on a semi-annual basis.

**Safekeeping and custody**

The CFO shall select one or more financial institutions to provide safekeeping and custodial services for the city, in accordance with the provisions of Section 53608 of the California Government Code. Custodian banks will be selected on the basis of their ability to provide services for the city's account and the competitive pricing of their safekeeping related services. The CFO shall maintain a file of the credit rating analysis reports performed semi-annually for each approved financial institution. A Safekeeping Agreement approved by the city shall be executed with each custodian bank prior to utilizing that bank's safekeeping services.

The purchase and sale of securities and repurchase agreement transactions shall be settled on a delivery versus payment basis. All securities shall be perfected in the name of the city. Sufficient evidence to title shall be consistent with modern investment, banking and commercial practices.

All investment securities purchased by the city will be delivered by book entry and will be held in third-party safekeeping by a city approved custodian bank, or its Depository Trust Company (DTC) participant account.

**Portfolio performance**

The investment portfolio shall be designed to attain a market rate of return throughout budgetary and economic cycles, taking into account prevailing market conditions, risk constraints for eligible securities, and cash flow requirements. The performance of the city's investments shall be compared to the average yield on the U.S. Treasury security that most closely corresponds to the portfolio's actual weighted average effective maturity. When comparing the performance of the city's portfolio, its rate of return will be computed net of all fees and expenses.

**Portfolio review and reporting**

Credit criteria and maximum percentages listed in this section refer to the credit of the issuing organization and/or maturity at the time the security is purchased. The city may, from time to time, be invested in a security whose rating is downgraded below the minimum ratings set forth in this policy. In the event a rating drops below the minimum allowed rating category for that given investment type, the administrative services director shall notify the city manager and/or designee and recommend a plan of action. Appropriate documentation of such a review, along with the recommended action and final decision shall be retained for audit.

Quarterly, the CFO shall submit to the City Council a report of the investment earnings and performance results of the city's investment portfolio. The report shall include the following information:

1. Investment type, issuer, date of maturity, par value and dollar amount invested in all securities, and investments and monies held by the city;
2. A description of the funds, investments and programs;
3. A market value as of the date of the report (or the most recent valuation as to assets not valued monthly) and the source of the valuation;
4. A statement of compliance with this Investment Policy or an explanation for not-compliance; and
5. A statement of the ability to meet expenditure requirements for six months, as well as an explanation of why money will not be available if that is the case.

**Policy review**

This investment policy shall be adopted by resolution of the City Council annually. It shall be reviewed at least annually to ensure its consistency with the overall objectives of preservation of principal, liquidity, yield and diversification and its relevance to current law and economic trends. Any amendments to the Policy shall be reviewed by the City's Finance and Audit Committee prior to being forwarded to the City Council for approval.



**Investment Policy**

City Council Procedure #CC-21-020

Adopted August 17, 2021

<b>Procedure history</b>		
Action	Date	Notes
Procedure adoption	January 14, 1997	Resolution No. 4784
Procedure adoption	February 17, 1998	Resolution No. 4871
Procedure adoption	February 2, 1999	Resolution No. 5064
Procedure adoption	February 13, 2001	Resolution No. 5283
Procedure adoption	May 9, 2000	Adopted by minute order
Procedure adoption	February 5, 2002	Resolution No. 5362
Procedure adoption	June 24, 2003	Resolution No. 5457
Procedure adoption	June 20, 2004	Resolution No. 5545
Procedure adoption	August 15, 2005	Resolution No. 5616
Procedure adoption	July 25, 2006	Resolution No. 5960
Procedure adoption	July 31, 2007	Resolution No. 5759
Procedure adoption	September 23, 2008	Resolution No. 5825
Procedure adoption	September 1, 2009	Resolution No. 5886
Procedure adoption	August 31, 2010	Resolution No. 5957
Procedure adoption	September 27, 2011	Resolution No. 6028
Procedure adoption	September 18, 2012	Resolution No. 6103
Procedure adoption	October 15, 2013	Resolution No. 6171
Procedure adoption	August 19, 2014	Resolution No. 6221
Procedure adoption	August 25, 2015	Resolution No. 6286
Procedure adoption	September 13, 2016	Resolution No. 6343
Procedure adoption	August 20, 2019	Adopted by minute order
Procedure adoption	August 11, 2020	Adopted by minute order
Procedure adoption	August 17, 2021	Resolution No. 6651



## STAFF REPORT

### City Council

Meeting Date: 8/17/2020  
Staff Report Number: 21-147-CC

Consent Calendar: Approve the 2021-22 Finance and Audit Committee work plan

### Recommendation

City staff and the Finance and Audit Committee recommend approval of the 2021-22 Finance and Audit Committee work plan.

### Policy Issues

City Council Procedure # CC-19-004 directs all advisory bodies to develop an annual workplan, finalized by a majority of the advisory body, and presented to the City Council for direction and approval on an annual basis.

### Background

The Finance and Audit Committee (FAC) met August 2, 2021 to review the prior year's workplan and draft a workplan for fiscal year 2021-22. FAC members present at the August 2, 2021 meeting, representing a majority of the committee, unanimously recommended approval of a workplan to City Council. The workplan, as recommended by the FAC, is included as Table 1.

The FAC largely completed the fiscal year 2019-20 workplan and City Council Procedure # CC 19-004 identifies a number of ongoing focus areas, including:

- Review the process for periodic financial reporting to the City Council and the public, as needed
- Review financial audit and annual financial report with the City's external auditors
- Review of the resolution of prior year audit findings
- Review of the auditor selection process and scope, as needed

### Analysis

City Council approved the 2020-21 FAC work plan at their August 25, 2020. Since that time, the committee has worked to meet its mission of facilitating an environment that focuses on accurate, efficient, and transparent financial reporting in an easy-to-understand format. At their August 2 special meeting, the FAC approved their 2021-22 work plan by a vote of 5-1 (City Councilmember Muller absent.)

Table 1: Finance and Audit Committee 2020-21 work plan			
Ref #	Title	Assignment	Status
1	Annual investment policy review	Full Committee	Complete, 8/2/21
2	Annual independent auditor's report review	Full committee	Week of 11/29/21
3	OpenGov transparency portal improvements and community training	Normington and Wong	Pending subcommittee work
4	Capital improvement plan review	Royse and Westcott	Pending subcommittee work
5	Communication of climate action plan costs to City and residents	Westcott	Pending subcommittee work

**Impact on City Resources**

There is no impact on City resources.

**Environmental Review**

This action is not a project within the meaning of the California Environmental Quality Act (CEQA) Guidelines §§ 15378 and 15061(b)(3) as it will not result in any direct or indirect physical change in the environment.

**Public Notice**

Public notification was achieved by posting the agenda, with the agenda items being listed, at least 72 hours prior to the meeting.

**Attachments**

None.

Report prepared by:  
 Nick Pegueros, Assistant City Manager



## STAFF REPORT

**City Council**  
**Meeting Date:** 8/17/2021  
**Staff Report Number:** 21-149-CC

**Consent Calendar:** **Adopt Resolution No. 6652 to reduce the posted speed limit in school zones consistent with the California Vehicle Code**

### Recommendation

Staff recommends that the City Council adopt Resolution No. 6652 (Attachment A) to reduce the posted speed limit in school zones consistent with the California Vehicle Code (CVC.)

### Policy Issues

This project is consistent with the City's circulation element, adopted in 2016, which includes the following goals and policies:

- Goal Circ-1: Provide and maintain a safe, efficient, attractive user-friendly circulation system that promotes a healthy, safe and active community and quality of life throughout Menlo Park.
- Policy Circ-1.1: Vision Zero. Eliminate traffic fatalities and reduce the number of non-fatal collisions by 50 percent by 2040.
- Policy Circ-1.5 Enforcement Program. Develop and implement enforcement program to encourage safe travel behavior and to reduce aggressive and/or negligent behavior among drivers, bicyclists and pedestrians.
- Policy CIRC-1.9 Safe Routes to Schools. Support Safe Routes to School programs to enhance the safety of school children who walk and bike to school.

Per Municipal Code section 11.12.010, the City Council, by resolution, orders the installation of traffic control devices including posted speed limit signs.

### Background

Speed plays a critical role in the cause and severity of crashes. In a collision between a vehicle and a pedestrian, for instance, speed influences the severity of injury and fatality risk of a pedestrian. Studies have shown that the severity of the injury and likelihood of fatality to the pedestrian increases as speed increases. According to the 1999 National Highway Traffic Safety Administration (NHTSA) "Literature Review on Vehicle Travel Speeds and Pedestrian Injuries" study, fatality and serious injury rates increase substantially when travel speeds rise. For children ages 14 and under, 20.2 percent suffer fatal or serious injuries when struck by a vehicle traveling 1-20 mph while 33.8 percent are killed or seriously injured when hit by a vehicle traveling 21-25 mph. Attachment B from the National Association of City Transportation Officials (NACTO) design guide shows how travel speeds can affect severity of crashes, driver behavior and vehicle operation. That is why it is important that safe speed limits be set for a specific road context and that proper enforcement and data collection measures be followed to ensure the desired speeds are achieved once a speed limit is set.

The limits/distance from schools that the school zone speed limits can be set is proscribed in the CVC and California-Manual on Uniform Traffic Control Devices (MUTCD) and staff follows this guidance. Some of the other cities that have implemented this guidance include cities of San Francisco, San Jose, Palo Alto, Sacramento, Mountain View and Los Altos.

On October 13, 2020, the City Council reviewed the 2019 Citywide engineering and traffic survey and passed the following motion:

1. Adopt Resolution No. 6593 approving the 2019 Citywide engineering and traffic survey with the following modifications:
  - Reduce speed limit on Olive Street from 30 mph to 25 mph
  - Reduce speed limit on O'Brien Drive from 30 mph to 25 mph
  - Reduce speed limit on the segment of Chilco Street between Constitution Drive and Terminal Avenue from 35 mph to 30 mph
2. Return with options for traffic calming on Middle Avenue to achieve a 25 mph zone.
3. Look at expanding the 25 mph school zones to the furthest extent of law.

Updated speed limit signs, per item 1 above, were installed in March 2021. Per item 2, the five-year capital improvement plan includes a project on Middle Avenue to develop project concepts.

The action identified for City Council consideration in this staff report would expand school zones per item 3. Even though the City Council's direction was to look at expanding the 25 mph school zones per item 3, the furthest extent of the law per the CVC allows the City to reduce the speed limit on school zones further to 15 mph that are less than 500 feet from the schools. Staff recommends that this be implemented to make the school zones even safer for school children that either bike or walk to school. Establishment of 15 mph speed limit zones in lieu of the 25 mph on roadway segments within 500 feet from schools is recommended due to the potential for fewer severe injury or fatal collisions with the use of a lower speed limit as shown in the 1999 NHTSA study described above and would help address the following pedestrian and bicycle collision data for Menlo Park. From the California Office of Traffic Safety crash ranking results, in 2018, out of the 97 incorporated cities in California with populations between 25,001 and 50,000, Menlo Park was ranked 12<sup>th</sup> and 4<sup>th</sup> for number of victims killed and injured for crashes involving pedestrians under the age of 15 years old and bicyclists under the age of 15 years old, respectively. The Transportation Injury Mapping System developed by UC Berkeley provides an interactive map of the bicycle and pedestrian collisions around schools. Attachment C is an example of such map for Belle Haven Elementary School. The 15 mph speed reduction can potentially reduce the bicycle and pedestrian collisions as well as the severity of the collisions for the school zones within ¼ mile of schools.

Staff has already installed 15 mph speed limit school zones on some streets at the Belle Haven Elementary School and at the Upper Laurel School in 2018. These were installed without City Council direction or action because staff thought that at that time it had the discretion to establish 15 mph limit school zones. Without a City Council resolution, however, this is not currently enforceable. On January 26, 2021, the City Council approved, in conjunction with the Sharon Road Sidewalk Project, the establishment of 15 mph speed limit zones around La Entrada Middle School.

The CVC, section 22358.4b(1) grants authority to local jurisdictions to 1) reduce the posted speed limit to 15 mph within 500 feet of the school grounds, and 2) extend the 25 mph posted speed limit in school zones from 500 feet to 1,000 feet from the school grounds, while children are going to or leaving the school, either during school hours or during the noon recess period.

This reduced or extended school zone speed limits per CVC 22358 4b(1) are applicable on roadway segments that meet the following conditions:

1. Within a residential district
2. Posted speed limit no greater than 30 mph immediately before and after the school zone.
3. No more than a total of two through lanes of traffic.

### **Analysis**

Staff identified the public and private schools with school zones and extended school zones that are proposed for either speed reduction to 15 mph posted speed limit or extension of the 25 mph posted speed limit in accordance with CVC Section 22358.4b(1.) The schools listed in Table 1 are limited to those wholly within Menlo Park's jurisdiction and whose school zones and extended school zones are wholly within Menlo Park's jurisdiction. Staff will work with the Town of Atherton and San Mateo County to consider speed limit reductions on the schools that serve Menlo Park residents but are not wholly within Menlo Park. These schools include Laurel School Lower Campus, Encinal Elementary School, Menlo Atherton High School, Menlo School and Sacred Heart Schools. TIDE Academy, a school wholly within Menlo Park's jurisdiction, is not included because its school zones and extended school zones are on roadway segments that are currently not within a residential district. The roadway segments proposed for either speed limit reduction of 15 mph or extension of 25 mph in Attachment A are wholly in the City's jurisdiction. Attachment D shows the map of the different schools in the list and the proposed school frontage extensions for the 15 mph speed limit. The speed limit signs are supplemented by "When Children are Present" signs.

Table 1: Schools identified for speed reduction

School name	Address	Grade	Type
1. Alto International School <sup>1</sup> KIPP Valiant Community Prep <sup>1</sup>	475 Pope St	Pre-K to 12 TK to 4 & 6-8	Private Public
2. Belle Haven Child Development Center <sup>1</sup> Belle Haven Elementary School <sup>1&amp;2</sup>	410 Ivy Dr 415 Ivy Dr	Pre-K K to 5	Public Public
3. Hillview Middle School <sup>1</sup>	1100 Elder Ave.	6 to 8	Public
4. La Entrada Middle School <sup>3</sup> Phillips Brooks School <sup>3</sup>	2200 Sharon Rd 2245 Avy Ave.	4 to 8 Pre-K to 5	Public Private
5. Laurel School Upper Campus <sup>2</sup>	275 Elliott Dr	3 to 5	Public
6. Lydian Academy	815 El Camino Real	6 to 12	Private
7. Menlo Atherton Cooperative Nursery School	802 Middle Ave.	Pre-K	Private
8. Menlo Children's Center	801 Laurel St	Pre-K	Public
9. Nativity School	1250 Laurel St	Pre-K to 8	Private
10. Oak Knoll Elementary School	1895 Oak Knoll Ln	K to 5	Public
11. Roberts School	641 Coleman Av	Pre-K	Private
12. St. Raymond's Elementary School	1211 Arbor Rd	K to 8	Private
13. Beechwood School	50 Terminal Ave.	Pre-K to 8	Private
14. Trinity School	2650 Sand Hill Rd	Pre-K to 5	Private
15. Kirk House Pre-School	950 Santa Cruz Ave.	Pre-K	Private
16. Bright Angel Montessori Academy	695 Bay Road	Pre-K	Private

## Notes:

1. These schools either share the same campus or very close to each other.
2. Currently has 15 mph zones on some roadway segments in proximity to Belle Haven Elementary School and Upper Laurel School.
3. City Council previously approved the 15 mph speed limit zones around La Entrada School January 26, 2021, but the signs have not been installed yet. Portions of 15 mph speed limit zones around La Entrada also apply to Phillips Brooks School because of its very close proximity to La Entrada School.

### Impact on City Resources

If approved by City Council, the costs of furnishing and installing the new posted speed limit signs in school zones and extended school zones would be borne by the City operating budget for its roadway signing maintenance. Staff anticipates this would cost approximately \$57,000, based on the bid prices provided by the City's signing and striping contractor. The installation costs are estimated to be approximately \$27,000 and the purchase costs of the signs and poles are estimated at \$30,000. The sign installation would be completed in either late October or early November through the City's signing and striping contractor.

## **Environmental Review**

The proposed installations are minor upgrades to an existing residential street right-of-way and would not result in any new impacts to the existing environment. This project is considered as a minor alteration to the existing street system, and therefore categorically exempt (Class 1 Exemption, Section 15301) from the provisions of the California Environmental Quality Act (CEQA.)

## **Public Notice**

Public notification was achieved by posting the agenda, with the agenda items being listed, at least 72 hours prior to the meeting.

## **Attachments**

- A. Resolution No. 6652
- B. How Speed Kills (From NACTO Design Guide) Pedestrian and Bicycle Collision Around School Map
- C. Belle Haven Elementary School example map
- D. Map of proposed school frontage extensions

Report prepared by:  
Rene Baile, Associate Transportation Engineer

Report reviewed by:  
Kristiann Choy, Acting Transportation Manager



**RESOLUTION NO. 6652****RESOLUTION OF THE CITY COUNCIL OF THE CITY OF MENLO PARK TO REDUCE THE POSTED SPEED LIMIT TO 15 MPH WITHIN 500 FEET OF THE SCHOOL GROUNDS, AND EXTEND THE 25 MILES PER HOUR POSTED SPEED LIMIT IN SCHOOL ZONES FROM 500 FEET TO 1,000 FEET FROM THE SCHOOL GROUNDS, WHILE CHILDREN ARE GOING TO OR LEAVING THE SCHOOL, EITHER DURING SCHOOL HOURS OR DURING THE NOON RECESS PERIOD**

WHEREAS, California Vehicle Code (CVC) Section 22358.4b(1) grants authority to local jurisdictions to 1) reduce the posted speed limit to 15 mph within 500 feet of the school grounds, and 2) extend the 25 miles per hour posted speed limit in school zones from 500 feet to 1,000 feet from the school grounds, while children are going to or leaving the school, either during school hours or during the noon recess period, and,

WHEREAS, the reduced or extended school zone speed limits per CVC Section 22358b(1) are consistent with several goals and policies in the City's circulation element, adopted in 2016, specifically Goal Circ. 1, Policy Circ. 1-1, Policy Circ. 1-5, and Policy Circ. 1-9, and,

WHEREAS, the City of Menlo Park, acting by and through its City Council, having considered and been fully advised in the matter and good cause appearing therefor,

BE IT AND IT IS HEREBY RESOLVED by the City Council of the City of Menlo Park that the City Council does hereby determine and justify pursuant to CVC Section 22358.4(b)(1) that 15 miles per hour shall be the prima facie speed limit at a distance within 500 feet of the school grounds and 25 miles per hours in school zones from 500 feet to 1000 feet from the school grounds on the road segments shown below while children are going to or leaving the school, either during school hours or during the noon recess period:

Table 1					
Number	School Name	Road Segments	Posted or Prima Facie Speed Limit (mph)	Recommended School Zone Speed Limit (mph)	
1	Alto International School	Pope St	25	15	
	KIPP Valiant Community Prep	Elm St	25	15	
2	Belle Haven Child Development Center	Ivy Dr	25	15	
		Chilco St	25	15	
		Belle Haven Elementary School	Ivy Drive	25	15
		Almanor Ave	25	15	
		Chilco St	25	15	
		Hamilton Ave	25	15	

Number	School Name	Road Segments	Posted or Prima Facie Speed Limit (mph)	Recommended School Zone Speed Limit (mph)
		Henderson Ave	25	15
3	Hillview Middle School	Santa Cruz Ave	25	15
		Elder Ave	25	15
		Olive St	25	15
4	La Entrada Middle School	Avy Ave	25	15
	Phillips Brooks School	Sharon Rd	25	15
		Bellair Way	25	15
		Altschul Ave	25	15
		Harkins Ave	25	15
5	Laurel School Upper Campus	O'Connor St	25	15
		Elliott Dr	25	15
		Oak Ct	25	15
6	Lydian Academy	Roble Ave	25	15
7	Menlo Atherton Cooperative Nursery School	Middle Ave	30/25	25/15
		Blake St	25	25
8	Menlo Children's Center	Laurel St	25	15
		Ravenswood Ave	30/25	25/15
9	Nativity School	Oak Grove Ave	25	15
		Laurel St	25	15
10	Oak Knoll Elementary School	Oak Knoll Ln	25	15
11	Roberts School	Coleman Ave	25	15
12	St. Raymond's Elementary School	Arbor Rd	25	15
		Santa Cruz Ave	25	15
13	Beechwood School	Terminal Ave	25	15

Number	School Name	Road Segments	Posted or Prima Facie Speed Limit (mph)	Recommended School Zone Speed Limit (mph)
		Del Norte Ave	25	15
14	Trinity School	Monte Rosa Dr	25	15
15	Kirk House Pre-School	Johnson St	25	15
16	Bright Angel Montessori Academy	Bay Road	30	25/15
		Hollyburne Ave	25	15

I, Judi A. Herren, City Clerk of Menlo Park, do hereby certify that the above and foregoing City Council Resolution was duly and regularly passed and adopted at a meeting by said City Council on the seventeenth day of August, 2021, by the following votes:

AYES:

NOES:

ABSENT:

ABSTAIN:

IN WITNESS WHEREOF, I have hereunto set my hand and affixed the Official Seal of said City on this seventeenth day of August, 2021.

---

Judi A. Herren, City Clerk

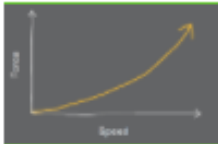

## How Speed Kills

1

Crashes at higher speeds are more forceful and thus more likely to be fatal

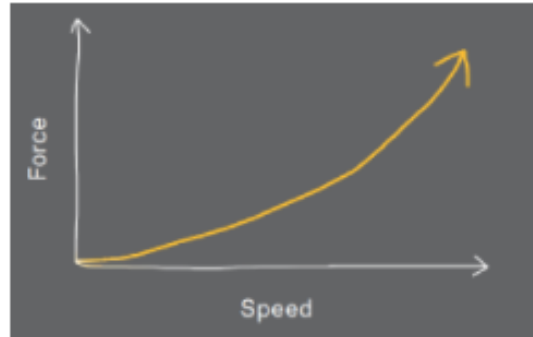

2

Drivers traveling at higher speeds have a narrower field of vision

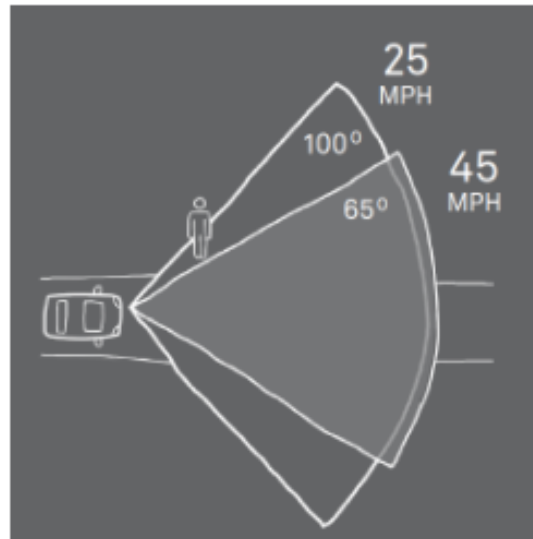

3

Drivers traveling at higher speeds travel further before they can react

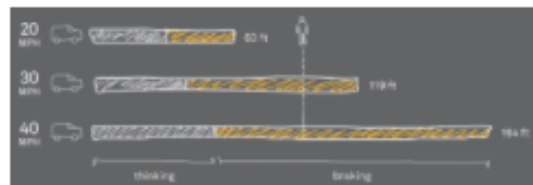

4

Vehicles traveling at higher speeds have longer braking distances

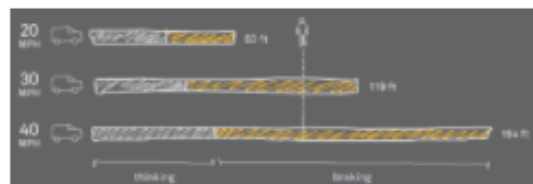

Interactive map and data summaries of bicycle and/or pedestrian collisions around school.

Types of Collisions:  cycle  Pedestrian  
 Collision Severity:  Fatal  Severe Injury  Other Visible Injury  Complaint of Pain  
 Years: 2016 - 2018

## Belle Haven Elementary

415 Ivy Drive | Menlo Park | San Mateo County | CDS: 41689996044309

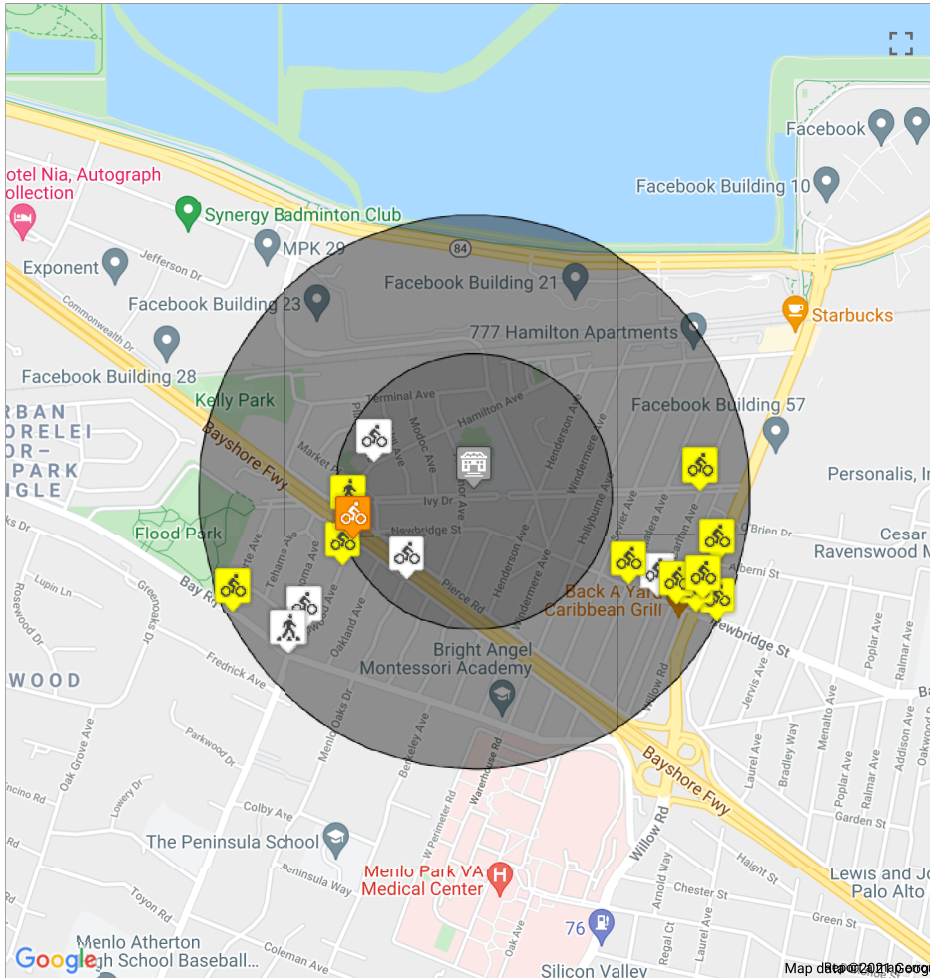

### Summary Statistics

Radius	Fatal	Severe Injury	Visible Injury	Complaint of Pain	Pedestrian	Bicycle	Total
< 1/4 mi.	0	1	2	2	1	4	5
1/4 - 1/2 mi.	0	0	9	4	1	12	13
<b>Total</b>	<b>0</b>	<b>1</b>	<b>11</b>	<b>6</b>	<b>2</b>	<b>16</b>	<b>18</b>

### Collision List

# City of Menlo Park: Proposed School Frontage Extensions





## STAFF REPORT

### City Council

Meeting Date:

8/17/2021

Staff Report Number:

21-150-CC

Consent Calendar:

**Award an on-call construction contract to Catos General Engineering, Inc. for the On-call asphalt and concrete repair services project**

### Recommendation

Staff recommends that the City Council award an on-call construction contract (Attachment A) to Catos General Engineering, Inc. for the on-call asphalt and concrete repair services project (Project) and authorize the city manager the option to extend the agreement for up to two additional years. The Project's maximum contract value is \$750,000 and will be funded through gas tax funds.

### Policy Issues

This Project is consistent with the City's goal of maintaining its municipal infrastructure and extending the life and safety of its roadway network. The Project is also included in the fiscal year 2021-22 capital improvement plan (CIP) as part of the street resurfacing project.

### Background

Menlo Park uses a pavement management system (PMS) that is approved by the Metropolitan Transportation Commission (MTC.) Through grants provided by the MTC, a pavement management technical assistance program report is generated every two years. This report evaluates the City's streets and develops a list of potential roadway maintenance projects, based on pavement condition and budgeting. These recommended projects from the PMS are reviewed by staff for inclusion in the CIP.

While this program is an effective tool for managing and maintaining City streets at an appropriate level of service overall, pavement damage and drainage issues are also reported throughout the year by roadway users and staff. These are often isolated areas of failure, and as such, need to be repaired more quickly than the annual resurfacing program in the CIP. Small repairs that do not require the restoration of large street segments are addressed by public works maintenance staff. By contrast, other repairs that involve larger restoration areas, design requirements, or complex traffic controls employ contractors. For example, tree roots have damaged a portion of Ravenswood Avenue between El Camino Real and the Caltrain railroad tracks. This should be remedied to prevent further deterioration of the road, however, traffic controls and arborist requirements are beyond the capacity of maintenance staff. Consequently, staff must procure a licensed contractor through the construction bidding process which delays the repair schedule. Such delays may further exacerbate pavement conditions and result in more expensive restoration measures. To be cost effective, and to improve the timeliness of such repairs, staff developed an on-call construction contract for asphalt and concrete repair services.

## Analysis

### Project description

This on-call Project allows staff to issue asphalt and concrete repairs to a licensed contractor, based on demand. To expedite repair work, the on-call contractor is required to begin construction within 30 working days from a given work order. The on-call contract is budgeted up to \$750,000 and is valid to the end of this fiscal year (June 30, 2022) with an option to renew up to two one-year extensions thereafter. The Project's scope of work generally includes the following services as directed by staff:

- Installing hot mix asphalt overlays or six-inch base repairs (dig-outs) to correct failing pavement
- Slurry sealing where preventative maintenance is required
- Installing concrete curb and gutters to correct drainage issues
- Installing concrete curb ramps, sidewalks, or driveways per the Americans with Disabilities Act
- Adjusting utilities to grade where the utilities overlap asphalt or concrete repair work
- Installing new signing and thermoplastic striping where overlapping asphalt or concrete repair work

The full extent of work is unknown as repairs will be identified or reported throughout the duration of the contract. However, select locations may be prioritized for repair based on areas of known pavement failures. These areas include the aforementioned uprooted section of Ravenswood Avenue between El Camino Real and the Caltrain railroad tracks. Other prioritized repairs may include resurfacing the Union Pacific Railroad (UPRR) crossing at Marsh Road. Pending contract award, select work in these areas may be scheduled during the 2021 autumn or winter seasons, weather permitting.

### Construction Bidding

Given the on-call nature of the Project, exact quantities and locations of work cannot be outlined in the bid package. Thus, the low bid was determined from a sample project that best reflects the magnitude of a potential on-call work order. Unit prices from the low bid will be used to estimate actual construction costs when a future on-call repair is requested. This estimate will be reviewed against remaining project funds before construction. On June 24, the City solicited bids from prospective contractors for the Project. Project bids were opened July 20, with results per Table 1. Of the three bids received based on the sample project, Catos General Engineering, Inc. offered the lowest price at \$133,300 and was under the engineer's estimate of \$204,940. As noted, the sample project is solely used for calculating the low bid and the project's maximum contract value is \$750,000.

Bidder	Sample project
Engineer's estimate	\$204,940
Catos General Engineering, Inc.	\$133,300
Golden Bay Construction, Inc.	\$236,067
O'Grady Paving, Inc.	\$835,100

Assuming the sample project reflects one work order, and factoring a 10 percent contingency, the low bidder's estimate is \$154,000 per mobilization. Consequently, there is available funding for a maximum of five separate work orders in this hypothetical scenario. Note that these figures may vary due to the on-call nature of this contract. Staff determined the lowest bidder to be experienced with projects involving similar work for asphalt and concrete improvements. The low bidder was also found to be responsive and



responsible per the project contract and public contracting code requirements.

### **Impact on City Resources**

The Project is budgeted up to \$750,000 for construction. There is sufficient funding in the street resurfacing project budget to finance this work using gas tax funds. Any excess monies upon expiration of the contract will be re-allocated to this fund. Staff recommends that the City Council award a \$750,000 on-call construction contract to Catos General Engineering, Inc. for the on-call asphalt and concrete repair services project.

### **Environmental Review**

This project is categorically exempt pursuant to California Environmental Quality Act (CEQA) Guidelines §§ 15301(b) Existing Facilities.

### **Public Notice**

Public notification was achieved by posting the agenda, with the agenda items being listed, at least 72 hours prior to the meeting.

### **Attachments**

A. Construction contract

Report prepared by:  
Phillip Linarte, Associate Civil Engineer  
Michael Fu, Senior Civil Engineer

Report reviewed by:  
Karen Pachmayer, Interim Assistant Public Works Director

**CONSTRUCTION AGREEMENT**

City Manager's Office  
701 Laurel St., Menlo Park, CA 94025  
tel 650-330-6620



<b>Agreement #:</b>
<b>AGREEMENT FOR SERVICES BETWEEN THE CITY OF MENLO PARK AND CATOS GENERAL ENGINEERING, INC.</b>
THIS CONSTRUCTION CONTRACT ("Contract") is made and entered into this _____ ("Execution Date") by and between the CITY OF MENLO PARK, a California municipal corporation, ("City") and CATOS GENERAL ENGINEERING, INC. ("Contractor").
<b>RECITALS</b>
<p>A. Contractor is a <u>California Corporation</u> duly organized and in good standing in the State of California, License Number <u>1000087</u>. Contractor represents and warrants that it has the background and experience set forth in the Contractor's responses to the notice inviting bids.</p> <p>B. Contractor represents that it is duly licensed by the State of California and has the background, knowledge, experience and expertise to perform the obligations set forth in this Contract.</p> <p>C. On <u>June 24, 2021</u>, the City issued a Notice to Contractors inviting bids for the Project. A copy of the Contractor's Bid proposal and List of Subcontractors is attached herein and incorporated by this reference.</p> <p>D. The City desires to retain Contractor as an independent contractor to provide the construction and other services identified in this Contract for the Project upon the terms and conditions contained herein.</p>
<b>AGREEMENT</b>
<p>NOW, THEREFORE, in consideration of performance by the parties of the promises, covenants and conditions contained herein, the parties hereby agree as follows:</p> <p>1. DEFINITIONS. Capitalized terms used throughout the Contract Documents shall have the meanings set forth in this Contract and/or the Special Provisions. If there is a conflict between the definitions in this Contract and the Special Provisions, the definitions in this Contract shall prevail.</p> <p>2. PROJECT. The project is the construction of <u>Citywide Asphalt and Concrete Repair Services project</u> ("Project"). The work includes all labor, materials, equipment, services, permits, licenses and taxes, and all other things necessary for Contractor to perform its obligations and complete the Project, including, without limitation, any Change Orders executed by City and Contractor in accordance with the requirements of the Contract Documents ("Work").</p> <p>3. CONTRACT DOCUMENTS.</p> <p>3.1 List of Documents. The Contract Documents (sometimes collectively referred to as "Agreement" or "Bid Documents") consist of the following documents which are on file with the Public Works Department and are hereby incorporated by reference.</p> <p>1) Change Orders 2) Field Orders</p>

- 3) Contract
- 4) Bidding Addenda
- 5) Special Provisions
- 6) Project Plans and Drawings
- 7) Technical Specifications
- 8) City Standard Details
- 9) State of California Department of Transportation Specifications, 2006 Edition (Cal Trans specifications)
- 10) Notice to Contractors
- 11) Contractor's Bid
- 12 Bidder Certifications, Questionnaire and Statements
- 13) Reports listed in the Contract Documents
- 14) City of Menlo Park Waste Management Form, Waste Management Daily Transport Report
- 15) City of Menlo Park Truck Route Map and Regulations
- 16) Performance, Payment and Maintenance Bonds

3.2 Order of Precedence. For the purposes of construing, interpreting and resolving inconsistencies between and among the provisions of this Contract, the Contract Documents shall have the order of precedence as set forth in the preceding section. If a claimed inconsistency cannot be resolved through the order of precedence, the City shall have the sole power to decide which document or provision shall govern as may be in the best interests of the City.

4. PERMITS. Contractor, at its sole expense, shall obtain and maintain during the term of this Contract, all appropriate permits, licenses and certificates that may be required in connection with the performance of the Work, including, but not limited to, a City business license.

5. DEPARTMENT OF INDUSTRIAL RELATIONS. Contractor and any subcontractor performing Work on this Project shall be registered with the Department of Industrial Relations ("DIR") pursuant to Labor Code Section 1725.5. No contractor or subcontractor may be listed on a bid proposal for a public works project unless registered with the DIR pursuant to Labor Code Section 1725.5, with limited exceptions from this requirement for bid purposes only under Labor Code Section 1771.1(a). This Project is subject to compliance monitoring and enforcement by the DIR. It is the responsibility of the Contractor to ensure all DIR requirements and regulations are met and stay current. For more information, see <http://dir.ca.gov/Public-Works/SB854.html>.

6. TERM. This Contract is effective on the Execution Date set forth in the initial paragraph of this Contract and shall remain in effect until the Project has been satisfactorily completed by Contractor, unless earlier terminated pursuant to the terms of this Contract.

7. TIME OF COMPLETION. Time is of the essence with respect to all time limits set forth in the Contract Documents. Contractor shall commence the Work on the date specified in the City's Notice to Proceed. Contractor shall diligently prosecute the Work to Substantial Completion within 30 calendar days after the date specified in the City's Notice to Proceed ("Contract Time"). The Contract Time may only be adjusted for extensions of time approved by the City and agreed to by Change Order executed by City and Contractor in accordance with the requirements of the Contract Documents.

8. COMPENSATION. The City agrees to compensate Contractor for its satisfactory completion of the Work in compliance with the Contract Documents for the not to exceed amount of One Hundred Thirty-Three Thousand Three Hundred (\$133,300) ("Contract Sum"). Payment shall be as set forth in the Plans, Special Provisions and/or Technical Specifications. The Contract Sum may only be adjusted by Change Orders issued, executed and satisfactorily performed by Contractor in accordance with the

requirements of the Contract Documents. The Contract Sum shall be adjusted (upward or downward) only to account for Change Orders. The Contract Sum is and shall be full compensation for all Work performed by Contractor. The Contract Sum shall cover all losses arising out of the nature of the Work or from the elements or any unforeseen difficulties or obstructions which may arise or be encountered in performance of the Work until its Acceptance by the City, all risks connected with the Work and any and all expenses incurred due to the suspension or discontinuance of the Work.

9. STANDARD OF PERFORMANCE. As a material inducement to the City to enter into this Contract, Contractor hereby represents and warrants that it has the qualifications and experience necessary to undertake the Work to be provided and the Project to be completed pursuant to this Contract. Contractor agrees that the Work shall be performed by qualified, experienced and well-supervised personnel. The Work performed pursuant to this Contract shall be performed in a manner consistent with the standard of care under California law applicable to those who specialize in providing such services for projects of the type, scope and complexity of the Project.

10. COMPLIANCE WITH LAW. This Project constitutes a public work within the meaning of California Labor Code Section 1720 et. seq. and is subject to prevailing wage laws. The Work performed by Contractor pursuant to this Contract shall be provided in accordance with all ordinances, resolutions, statutes, rules and regulations of the City, and any federal, state or local governmental agency having jurisdiction in effect at the time the work is rendered.

11. REPRESENTATIVE. Santosh B Reddappa is hereby designated as the project manager/superintendent/foreman of Contractor authorized to act on its behalf with respect to the Work specified in this Contract. It is expressly understood that the experience, knowledge, capability and reputation of Catos General Engineering, Inc. were a substantial inducement for City to enter into this Contract. Therefore, Santosh B Reddappa shall be responsible during the term of this Contract for directing all activities of Contractor and devoting sufficient time to personally supervise the services hereunder. The representative may not be changed by Contractor without the express written approval of the City.

## 12. LIQUIDATED DAMAGES.

12.1 Entitlement. City and Contractor acknowledge and agree that if Contractor fails to fully and satisfactorily complete the Work within the Contract Time, the City will suffer, as a result of Contractor's failure, substantial damages which are both extremely difficult and impracticable to ascertain. Such damages may include, but are not limited to: (a) loss of public confidence in the City and its contractors; (b) loss of public use of public facilities; and (c) extended disruption to public.

12.2 Daily Amount. City and Contractor have reasonably endeavored, but failed, to ascertain the actual damage that the City will incur if the Contractor fails to achieve Substantial Completion of the Work within the Contract Time. Therefore, the parties agree that in addition to all other damages to which the City may be entitled other than delay damages, in the event the Contractor shall fail to achieve Substantial Completion of the Work within the Contract Time, Contractor shall pay City as liquidated damages the amount of five hundred Dollars (\$500) per day for each calendar day after the expiration of the Contract Time until Contractor achieves Substantial Completion of the Work. The liquidated damages amount is not a penalty, but a reasonable estimate of the amount of damages the City will suffer.

12.3 Apportionment. Such liquidated damages shall be subject to reduction for delays for which Contractor is entitled to receive an extension of time under the Contract Documents ("Apportionment"). Such Apportionment shall not be affected by the fact that liquidated damages may not be applied for

periods of time during which delays have occurred that are caused by both City and Contractor. It is agreed that the liquidated damages shall not be applied for portions of the Work completed prior to the expiration of the Contract Time.

12.4 Exclusive Remedy. City and Contractor acknowledge and agree that this Section 11, Liquidated Damages, shall be the City's only remedy for delay damages caused by the Contractor's failure to achieve Substantial Completion of the Work within the Contract Time.

12.5 Damages upon Abandonment. In the event that the Contractor either abandons the Work or is terminated for default in accordance with the provisions of this Contract, City shall have the right, in its sole discretion exercised by written notice issued either before or after Substantial Completion, to elect to either assert or waive its right to liquidated damages. If City elects to assert its right to liquidated damages, then the liquidated damages shall be calculated from expiration of the Contract Time to the date that Substantial Completion of the Work is achieved by the City or its replacement contractor employed to complete Contractor's performance. If City elects to waive its right to liquidated damages, then Contractor shall be liable to the City, in lieu of the liquidated damages, for all actual Losses (as defined in the General Conditions) proximately resulting from Contractor's failure to complete the Work within the Contract Time.

12.6 Other Remedies. The parties further acknowledge and agree that the City is entitled to any and all available legal and equitable remedies City may have where City's Losses are caused by any reason other than Contractor's failure to achieve Substantial Completion of the Work within the Contract Time.

13. INDEPENDENT CONTRACTOR. Contractor is, and shall at all times remain as to the City, a wholly independent contractor and not an agent or employee of the City. Contractor shall receive no premium or enhanced pay for work normally understood as overtime, nor shall Contractor receive holiday pay, sick leave, administrative leave, or pay for any other time not actually worked. The intention of the parties is that Contractor shall not be eligible for benefits and shall receive no compensation from the City except as expressly set forth in this Contract. Contractor shall have no power to incur any debt, obligation, or liability on behalf of the City or otherwise act on behalf of the City as an agent. Neither the City, nor any of its agents shall have control over the conduct of Contractor, any of Contractor's employees, or any subcontractors, except as set forth in this Contract. Contractor shall at no time, or in any manner, represent that it or any of its agents or employees or subcontractors are in any manner employees of the City. Contractor agrees to pay all required taxes on amounts paid to Contractor under this Contract, and to indemnify and hold the City harmless from any and all taxes, assessments, penalties, and interest asserted against the City by reason of the independent contractor relationship created by this Contract. Contractor shall fully comply with the worker's compensation law regarding Contractor, Contractor's employees and subconsultants. Contractor further agrees to indemnify and hold the City harmless from any failure of Contractor and any subconsultants to comply with applicable worker's compensation laws.

14. CONFLICT OF INTEREST. Contractor covenants that it presently has no interest and shall not acquire any interest, direct or indirect, which may be affected by the work to be performed by Consultant under this Contract, or which would conflict in any manner with the performance of its services hereunder. Contractor further covenants that, in performance of this Contract, no person having any such interest shall be employed by it. Furthermore, Contractor shall avoid the appearance of having any interest which would conflict in any manner with the performance of the work pursuant to this Contract. Contractor agrees not to accept any employment during the term of this Contract which is or may make Contractor financially interested, as provided in California Government Code Sections 1090 and 87100, in any decision made by the City on any matter in connection with which Contractor has been retained pursuant to this Contract. However, nothing herein shall preclude Contractor from

accepting other engagements with the City.

## 15. INDEMNIFICATION.

15.1 To the fullest extent permitted by law, Contractor shall indemnify, defend, with independent counsel approved by the City, and hold harmless the City, and its elective or appointive boards, officers, employees agents and volunteers ("Indemnitee") from and against any and all claims, losses, or liability that may arise out of or result from damages to property or personal injury received by reason of, or in the course of work performed under this Contract due to the acts or omissions of Contractor or Contractor's officers, employees, agents or subcontractors. The indemnification provisions survive completion of the Work or the termination of this Contract. The acceptance of such services shall not operate as a waiver of such right of indemnification. Notwithstanding the foregoing, nothing contained herein shall be construed as obligating Contractor to indemnify any Indemnitee for any claims, losses or liability resulting from the sole or active negligence or willful misconduct of the Indemnitee. Contractor shall pay City for any costs incurred in enforcing this provision.

15.2 The City does not and shall not waive any rights that they may possess against Contractor because of the acceptance by the City or the deposit with the City of any insurance policy or certificate required pursuant to this Contract. This hold harmless and indemnification provision shall apply regardless of whether or not any insurance policies are determined to be applicable to the claim, demand, damage, liability, loss, cost or expense.

15.3 Pursuant to Public Contract Code Section 9201, the City shall timely notify Contractor upon receipt of any third-party claim relating to the Contract.

16. ASSIGNABILITY. The parties agree that the experience and qualifications of Contractor as set forth in the Contractor's Bid are material considerations for the City entering into this Contract. Consultant shall not assign or transfer any interest in this Contract, without the prior written consent of the City, and any attempt by Contractor to do so shall be void and of no effect and a breach of this Contract. For purposes of this section, the sale, assignment, transfer or other disposition of any of the issued and outstanding capital stock of Contractor or of any general partner or joint venturer or syndicate member of Contractor, if a partnership or joint venture or syndicate or co-tenancy exists, which shall result in changing the control of Contractor, shall be construed as an assignment of this Construction Contract. Control means more than fifty percent (50%) of the voting power of the corporation or other entity.

## 17. INSURANCE AND BOND REQUIREMENTS.

17.1 Prior to the commencement of any Work, the Contractor shall provide the City with evidence that it has obtained the insurance required by this Section and all bonds, including, but not limited to, payment and performance bonds, required in the Special Provisions. Failure to obtain and maintain the required insurance and bonds to so shall be deemed a material breach of this Contract.

17.2 Insurance Requirements. Contractor shall obtain the following insurance.

A. Worker's Compensation and Employer's Liability Insurance: The CONTRACTOR shall have in effect during the entire life of this Contract workers' compensation and Employer's Liability Insurance providing full statutory coverage. In signing this Contract, the CONTRACTOR makes the following certification, required by Section 18161 of the California Labor Code: "I am aware of the provisions of Section 3700 of the California Labor Code which require every employer to be insured against liability for workers' compensation or to undertake self-insurance in accordance with the provisions of the Code, and I will comply with such provisions before commencing the performance of the work of this Contract."

B. Commercial General Liability Insurance: The CONTRACTOR shall take out and maintain during the life of this Contract such Bodily Injury Liability and Property Damage Liability Insurance (Commercial General Liability Insurance) on an occurrence basis as shall protect it while performing work covered by this Contract from any and all claims for damages for bodily injury, including accidental death, as well as claims for property damage which may arise from the CONTRACTOR's operations under this Contract, whether such operations be by CONTRACTOR or by any sub-consultant or by anyone directly or indirectly employed by either of them. The amounts of such insurance shall be not less than two million dollars (\$2,000,000) per occurrence and four million dollars (\$4,000,000) in aggregate, or four million dollars (\$4,000,000) combined single limit bodily injury and property damage for each occurrence. CONTRACTOR shall provide the City with acceptable evidence of coverage, including a copy of all declarations of coverage exclusions.

C. Automobile Liability Insurance: CONTRACTOR shall maintain Automobile Liability Insurance pursuant to this Contract in an amount of not less than one million dollars (\$1,000,000) for each accident combined single limit or not less than one million dollars (\$1,000,000) for any one (1) person, and one million dollars (\$1,000,000) for any one (1) accident, and Three Hundred Thousand Dollars, (\$300,000) property damage.

17.3 CITY and its subsidiary agencies, and their officers, agents, employees and servants shall be named as additional insured on any such policies of Commercial General Liability and Automobile Liability Insurance, (but not for the workers' compensation), which shall also contain a provision that the insurance afforded thereby to the CITY, its subsidiary agencies, and their officers, agents, employees, and servants shall be primary insurance to the full limits of liability of the policy, and that if the CITY, its subsidiary agencies and their officers and employees have other insurance against a loss covered by a policy, such other insurance shall be excess insurance only.

17.4 In the event of the breach of any provision of this Section, or in the event any notice is received which indicates any required insurance coverage will be diminished or canceled, CITY, at its option, may, notwithstanding any other provision of this Contract to the contrary, immediately declare a material breach of this Contract and suspend all further work pursuant to this Contract.

17.5. Before the execution of this Contract, any deductibles or self-insured retentions must be declared to and approved by CITY.

18. SUSPENSION. The City may, at any time and from time to time, without cause, order Contractor, in writing ("Suspension Order"), to suspend, delay, or interrupt the Work in whole or in part for such period of time, up to an aggregate of fifty percent (50%) of the Contract Time, as City may determine, with such period of suspension to be computed from the date of the Suspension Order. Upon receipt of a Suspension Order, Contractor shall, at City's expense, comply with its terms and take all reasonable steps to minimize costs allocable to the Work covered by the Suspension Order during the period of work stoppage. Within the period of the above noted aggregate time, or such extension to that period as is agreed upon by Contractor and City, City shall either cancel the Suspension Order or delete the work covered by the Suspension Order by issuing a Change Order. If a Suspension Order is canceled or expires, Contractor shall resume and continue with the Work. A Change Order will be issued to cover any adjustments of the Contract Sum or the Contract Time necessarily caused by such suspension.

19. BOOKS AND RECORDS. Contractor shall keep full and detailed accounts and exercise such controls as may be necessary for proper financial management under this Contract in accordance with generally accepted accounting principles and practices consistently applied. City and City's accountants shall be afforded access at all times during normal business hours, to inspect, audit and copy Contractor's records, books, estimates, take-offs, cost reports, ledgers, schedules, correspondence,

instructions, drawings, receipts, subcontracts, purchase orders, vouchers, memoranda and other data relating to this Project, and Contractor shall preserve these for a period of three years after the later of (i) final payment or (ii) final resolution of all Contract Disputes and other disputes or for such longer period as may be required by law. Contractor's compliance with any request by City pursuant to this Section 18 shall be a condition precedent to filing or maintenance of any legal action or proceeding by Contractor against City and to Contractor's right to receive further payments under the Contract Documents. Any failure by Contractor to provide access to its business records for inspection or copying by City shall be specifically enforceable by issuance of a writ or a provisional or permanent mandatory injunction by a court of competent jurisdiction based on affidavits submitted to such court, without the necessity of oral testimony.

20. WAIVER. Waiver by either party of any breach or violation of any one or more terms or conditions of this Contract shall not be deemed to be a waiver of any other term or condition contained herein or a waiver of any subsequent breach or violation of the same or any other term or condition. Acceptance by the City of the performance of any work by the Contractor shall not be deemed to be a waiver of any term or condition of this Contract. In no event shall the City's making of any payment to Contractor constitute or be construed as a waiver by the City of any breach of this Contract, or any default which may then exist on the part of Contractor, and the making of any such payment by the City shall in no way impair or prejudice any right or remedy available to the City with regard to such breach or default.

21. DEFAULT. In the event the City determines, in its sole discretion, that Contractor has failed or refused to perform any of the obligations set forth in the Contract Documents, or is in breach of any provision of the Contract Documents, the City may give written notice of default to Contractor in the manner specified for this giving of notices in this Contract. Except for emergencies, Contractor shall cure any default in performance of its obligations under the Contract Documents within two (2) business days after receipt of written notice. However, if the breach cannot be reasonably cured within such time, Contractor will commence to cure the breach within two (2) days and will diligently and continuously prosecute such cure to completion within a reasonable time, which shall in no event be later than ten (10) days after receipt of such written notice.

## 22. CITY RIGHTS AND REMEDIES.

22.1 Remedies Upon Default. In the event that Contractor fails to cure any default of this Contract within the time period set forth in Section 20, then City may pursue any remedies available under law or equity, including, without limitation, the following: (1) the City may, without terminating the Contract, delete certain portions of the Work, reserving to itself all rights to losses related thereto; (2) the City may, without terminating the Contract, engage others to perform the Work or portion of the Work that has not been performed by the Contractor and withhold the cost thereof to City from future payments to the Contractor, reserving to itself all rights to Losses related thereto; or (3) the City may, without terminating the Contract and reserving to itself all rights to Losses related thereto, suspend all or any portion of this Construction Contract for as long a period of time as City determines, in its sole discretion, appropriate, in which event City shall have no obligation to adjust the Contract Sum or Contract Time, and shall have no liability to Contractor for damages if City directs Contractor to resume Work; (4) the City may terminate all or any part of this Contract for default, reserving to itself all rights to Losses related thereto; or (5) the City may, without terminating the Contract and reserving to itself all rights to Losses related thereto, exercise its rights under the Performance Bond.

22.2 Additional Provisions. All of City's rights and remedies under this Contract are cumulative, and shall be in addition to those rights and remedies available in law or in equity. Designation in the Contract Documents of certain breaches as material shall not be construed as implying that other breaches not so designated are not material nor shall such designations be construed as limiting City's



right to terminate the Contract, or the exercise of its other rights or remedies for default, to only material breaches. City's determination of whether there has been noncompliance with the Contract so as to warrant exercise by City of its rights and remedies for default under the Contract, shall be binding on all parties. No termination or action taken by City after such termination shall prejudice any other rights or remedies of City provided by law or equity or by the Contract Documents upon such termination; and City may proceed against Contractor to recover all liquidated damages and Losses suffered by City.

22.3 Delays by Sureties. Without limitation to any of City's other rights or remedies under the law, City has the right to suspend the performance by Contractor's sureties in the event of any of the following: (1) failure of the sureties to begin Work within a reasonable time in such manner as to insure full compliance with the Contract within the Contract Time; (2) abandonment of the Work; (3) if at any time City is of the opinion the Work is unnecessarily or unreasonably delayed; (4) willful violation of any terms of the Contract; (5) failure to perform according to the Contract Documents; or (6) failure to follow instructions of City for its completion within the Contract Time. City will serve notice of such failure upon the sureties and in the event the sureties neglect or refuse to cure the breach within the time specified in such notice, City shall have the power to suspend the performance or any part thereof of the sureties.

22.4 Damages to the City. The City will be entitled to recovery of all Losses under law or equity in the event of Contractor's default under the Contract Documents. In the event that City's Losses arise from Contractor's default under the Contract Documents, City shall be entitled to withhold monies otherwise payable to Contractor until Final Completion, as defined in the General Conditions, of the Project. If City incurs Losses due to Contractor's default, then the amount of Losses shall be deducted from the amounts withheld. Should the amount withheld exceed the amount deducted, the balance will be paid to Contractor or its designee upon Final Completion of the Project. If the Losses incurred by City exceed the amount withheld, Contractor shall be liable to City for the difference and shall promptly remit same to City.

22.5 Termination of the Contract for Default. Without limitation to any of City's other rights or remedies at law or in equity, and reserving to itself all rights to Losses related thereto, City shall have the right to terminate this Contract, in whole or in part, upon the failure of Contractor to promptly cure any default. City's election to terminate the Contract for default shall be communicated by giving Contractor a written notice of termination in the manner specified for the giving of notices in the Contract. Any notice of termination given to Contractor by City shall be effective immediately, unless otherwise provided therein.

22.6 Termination Without Cause. City shall have the option, at its sole discretion and without cause, of terminating this Contract in part or in whole by giving thirty (30) days written notice to Contractor. Contractor agrees to accept such sums as allowed under this Section as its sole and exclusive compensation and waives any claim for other compensation or Losses, including, but not limited to, loss of anticipated profits, loss of revenue, lost opportunity, or other consequential, direct, indirect or incidental damages of any kind.

22.7 Compensation. Following termination without cause and within forty-five (45) days after receipt of a billing from Contractor seeking payment of sums authorized by this Section, City shall pay to Contractor as its sole compensation for performance of the Work the following: (1) the amount of the Contract Sum allocable to the portion of the Work properly performed by Contractor as of the date of termination, less sums previously paid to Contractor; (2) reasonable costs of Contractor and its Subcontractors and Sub-subcontractors for demobilizing and administering the close-out of its participation in the Project (including, without limitation, all billing and accounting functions, not including attorney or expert fees) for a period of no longer than thirty (30) days after receipt of the notice of termination in an amount not to exceed the daily sum payable to Contractor for Compensable Delays;

(3) previously unpaid cost of any items delivered to the Project Site which were fabricated for subsequent incorporation in the Work.

22.8 Subcontractors. Contractor shall include provisions in all of its subcontracts, purchase orders and other contracts permitting termination for convenience by Contractor on terms that are consistent with this Contract and that afford no greater rights of recovery against Contractor than are afforded to Contractor under this Section.

22.9 Contractor's Duties Upon Termination. Upon receipt of a notice of termination for default or for convenience, Contractor shall, unless the notice directs otherwise, do the following: (1) immediately discontinue the Work to the extent specified in the notice; (2) place no further orders or subcontracts for materials, equipment, services or facilities, except as may be necessary for completion of such portion of the Work as is not discontinued; (3) provide to City a description, in writing no later than fifteen (15) days after receipt of the notice of termination, of all subcontracts, purchase orders and contracts that are outstanding, including, without limitation, the terms of the original price, any changes, payments, balance owing, the status of the portion of the Work covered and a copy of the subcontract, purchase order or contract and any written changes, amendments or modifications thereto, together with such other information as City may determine necessary in order to decide whether to accept assignment of or request Contractor to terminate the subcontract, purchase order or contract; (4) promptly assign to City those subcontracts, purchase orders or contracts, or portions thereof, that City elects to accept by assignment and cancel, on the most favorable terms reasonably possible, all subcontracts, purchase orders or contracts, or portions thereof, that City does not elect to accept by assignment; and (5) hereafter do only such Work as may be necessary to preserve and protect Work already in progress and to protect materials, plants, and equipment on the Project Site or in transit thereto.

23. CONTRACTOR'S RIGHTS AND REMEDIES. Contractor may terminate this Construction Contract for cause only upon the occurrence of one of the following: (1) the Work is stopped for sixty (60) consecutive days, through no act or fault of Contractor, any subcontractor or any employee or agent of Contractor or any subcontractor, due to issuance of an order of a court or other public authority other than City having jurisdiction or due to an act of government, such as a declaration of a national emergency making material unavailable; or (2) if the City does not make payment of sums that are not in good faith disputed by the City and does not cure such default within ninety (90) days after receipt of notice from Contractor, then upon an additional thirty (30) days' notice to City, Contractor may terminate the Contract.

23.1 Damages to Contractor. In the event of termination for cause by Contractor, City shall pay Contractor the sums provided for in Section 21 above. Contractor agrees to accept such sums as its sole and exclusive compensation and agrees to waive any claim for other compensation or Losses, including, but not limited to, loss of anticipated profits, loss of revenue, lost opportunity, or other consequential, direct, indirect and incidental damages, of any kind.

24. NOTICES. Any notices or other communications required or permitted to be given under this Contract shall be given in writing by personal delivery, by a recognized courier service, or by U.S. mail, postage prepaid, and return receipt requested, addressed to the respective parties as follows:

To City:

Assistant Public Works Director/City Engineer  
City of Menlo Park  
City Hall, 701 Laurel St.  
Menlo Park, CA 94025

To Contractor:

Catos General Engineering, Inc.  
22302 Hathaway Ave.  
Hayward, CA 94541

25. Notice shall be deemed communicated on the earlier of actual receipt or 48 hours after deposit in the U.S. mail, or the date of delivery shown on deliverer's receipt. In the event of any change of address, the moving party is obligated to notify the other party of the change of address in writing within a reasonable period of time.

In addition, copies of all Claims by Contractor under this contract shall be provided to the City Attorney as follows:

To City Attorney:

City Attorney  
Burke, Williams & Sorensen, LLP  
181 Third Street, Suite 200  
San Rafael, CA 94901

All claims shall be delivered personally or sent by certified mail.

26. NON-DISCRIMINATION AND EQUAL EMPLOYMENT OPPORTUNITY. In the performance of this Contract, Contractor shall not discriminate against any employee, subcontractor or applicant for employment because of race, color, creed, religion, sex, marital status, sexual orientation, national origin, ancestry, age, physical or mental handicap, or medical condition. Contractor will take affirmative action to ensure that employees are treated without regard to race, color, creed, religion, sex, marital status, sexual orientation, national origin, ancestry, age, physical or mental handicap, or medical condition.

27. CONTRACT DOCUMENTS AND PRECEDENCE. The Contract Documents shall consist of the following documents. In case of inconsistencies between Contract Documents, the documents are listed in order of precedence.

28. PUBLIC WORKS CLAIMS. This Contract is subject to Public Contracts Code Section 9204 governing contractor claims.

29. ATTORNEYS' FEES; VENUE. In the event that any party to this Contract commences any legal action or proceeding to enforce or interpret the provisions of this Contract, the prevailing party in such action or proceeding shall be entitled to recover reasonable attorneys' fees and other costs incurred in that action or proceeding, in addition to any other relief to which the successful party may be entitled. The venue for any litigation shall be San Mateo County.

30. COOPERATION. In the event any claim or action is brought against the City relating to Contractor's performance or services under this Agreement, Contractor shall render any reasonable assistance and cooperation which City might require.

31. NUISANCE. Contractor shall not maintain, commit, nor permit the maintenance or commission of any nuisance in connection with the performance of services under this Contract.

32. GOVERNING LAW. This Contract shall be construed in accordance with and governed by the laws of the State of California.

33. COMPLETE AGREEMENT; SEVERABILITY. This Contract, and any other documents incorporated herein by reference, represent the entire and integrated agreement between the City and Contractor. This Contract supersedes all prior oral and written negotiations, representations or agreements. No prior

oral or written understanding shall be of any force or effect with respect to those matters covered hereunder. This Contract may only be modified by a written amendment duly executed by the parties to this Contract. In case a provision of this Contract is held to be invalid, illegal or unenforceable, the validity, legality and enforceability of the remaining provisions shall not be affected.

34. COUNTERPARTS. This Contract may be signed in multiple counterparts, which shall, when executed by all the parties constitute a single binding contract.

SIGNATURE PAGE TO FOLLOW

IN WITNESS WHEREOF, the parties hereto have executed this agreement on the day and year first above written.

**FOR FIRST PARTY:**

\_\_\_\_\_  
Signature

\_\_\_\_\_  
Date

\_\_\_\_\_  
Printed name

\_\_\_\_\_  
Title

\_\_\_\_\_  
Tax ID#

**APPROVED AS TO FORM:**

\_\_\_\_\_  
Nira F. Doherty, City Attorney

\_\_\_\_\_  
Date

**FOR CITY OF MENLO PARK:**

\_\_\_\_\_  
Starla Jerome-Robinson, City Manager

\_\_\_\_\_  
Date

**ATTEST:**

\_\_\_\_\_  
Judi A. Herren, City Clerk

\_\_\_\_\_  
Date



## STAFF REPORT

**City Council**

**Meeting Date:** 8/17/2021

**Staff Report Number:** 21-151-CC

**Consent Calendar:** Award a construction contract to Terramark General Engineering Contractors Inc. for the Sharon Park walkways reconstruction project

### Recommendation

Staff recommends that the City Council award a construction contract (Attachment A) to Terramark General Engineering Contractors Inc. for \$343,380 and approve a 15 percent construction contingency of \$51,507 (held by the City) for the Sharon Park walkways reconstruction project.

### Policy Issues

The project is consistent with the City's General Plan Policy LU-6.1 that states the following: "Develop and maintain a parks and recreation system that provides areas, play fields, and facilities conveniently located and properly designed to serve the recreation needs of all Menlo Park residents." In keeping with the City's General Plan Policy, Sharon Park provides areas for walking, playing, exercising, and gathering by being conveniently located, suitably maintained, and designed to serve the recreational needs. The proposed Sharon Park walkways reconstruction project addresses the City's policy to properly maintain recreational facilities and is consistent with improvements identified for Sharon Park in the City's Parks and recreation master plan, adopted in 2019, to replace the walking paths around the lake.

### Background

Sharon Park is one of 16 City parks and open space areas, and is located generally between Sharon Park Drive, Monte Rosa Drive, Siskiyou Drive and Kamath Drive. The five-year capital improvement program includes an annual maintenance project for Park Pathways Repairs. In the last five years, pathway work was also completed at Jack W. Lyle with installation of the new restroom and Karl E. Clark Parks. Parks identified for pathway rehabilitation work include Sharon Park, Nealon Park, Stanford Hills Park, and as well as a new pathway connection in Willow Oaks Park to connect to Elm Street. This proposed project, the Sharon Park walkways reconstruction project, would complete repairs in Sharon Park. Nealon Park and Willow Oaks Park work are currently in the design phase.

The Sharon Park walkways reconstruction project will include:

- Reconstruction of the asphalt upper and lower walkways (pathways)
- Replacement of redwood header/bender boards
- Replacement of segments of existing damaged concrete curb and gutter
- Construction of an asphalt pad for City maintenance trucks adjacent to the upper walkway
- Paving for an Americans with Disabilities Act compliant parking stall
- Installation of new bollards

- Other miscellaneous minor work

**Analysis**

On May 28, 2021, bids were solicited from prospective contractors for the Sharon Park walkways reconstruction project via a competitive bidding process. On June 16, the City received six bids as shown in Table 1. Of the six project bids submitted, five were within the range of the engineer’s estimated cost with three of those five coming in lower than the engineer’s estimate.

Table 1: Bid results (Engineer’s estimate \$450,000)	
Contractor	Bid price (base bid)
1. Terramark General Engineering Contractors Inc.	\$ 343,380.00
2. GradeTech Inc.	\$ 351,650.00
3. Catos General Engineering, Inc.	\$ 393,735.00
4. Burch Engineering and Construction, Inc.	\$ 460,615.00
5. O’Grady Paving Inc.	\$ 496,750.00
6. NBC Construction & Engineering Inc.	\$ 584,957.28

Of the six bids received, Terramark General Engineering Contractors, Inc. submitted the lowest bid in the amount of \$343,380. After checking references, staff found the bidder to have positive background and related work experience responses on previous projects. Accordingly, the Terramark bid appears both responsive and responsible.

**Impact on City Resources**

Funding for the Sharon Park walkways reconstruction project is included in the capital improvement plan (CIP) under the Park pathways repair project. The available fund balance is \$1,370,000. The total project construction budget, including contingencies, inspection and materials testing, and contract administration is \$521,387. The total estimated construction cost would not exceed this amount, per Table 2.

Table 2: Construction budget	
Item	Amount
Project construction bid	\$343,380
Inspection and field testing services	\$69,000
Project administration	\$57,500
Construction contingency (15%) (held by City)	\$51,507
<b>Total construction cost</b>	<b>\$521,387</b>

Upon completion of construction, if funds remain, they will be returned to the CIP project fund to be used

on future park pathway rehabilitation work. Other parks identified for rehabilitation work include Nealon Park and Stanford Hills Park.

**Environmental Review**

This project is categorically exempt pursuant to California Environmental Quality Act (CEQA) Guidelines §§ 15301(d) Existing Facilities.

**Public Notice**

Public notification was achieved by posting the agenda, with the agenda items being listed, at least 72 hours prior to the meeting.

**Attachments**

A. Construction contract

Report prepared by:  
Rodolfo Ordonez, Associate Engineer

Report reviewed by:  
Karen Pachmayer, Interim Assistant Public Works Director



**CONSTRUCTION AGREEMENT**

City Manager's Office  
701 Laurel St., Menlo Park, CA 94025  
tel 650-330-6620



<b>Agreement #:</b>
<b>AGREEMENT FOR SERVICES BETWEEN THE CITY OF MENLO PARK AND TERRAMARK GENERAL ENGINEERING CONTRACTORS INC.</b>
THIS CONSTRUCTION CONTRACT ("Contract") is made and entered into this _____ ("Execution Date") by and between the CITY OF MENLO PARK, a California municipal corporation, ("City") and TERRAMARK GENERAL ENGINEERING CONTRACTORS INC. ("Contractor").
<b>RECITALS</b>
<p>A. Contractor is a California Corporation duly organized and in good standing in the State of California, License Number <u>1037977</u>. Contractor represents and warrants that it has the background and experience set forth in the Contractor's responses to the notice inviting bids.</p> <p>B. Contractor represents that it is duly licensed by the State of California and has the background, knowledge, experience and expertise to perform the obligations set forth in this Contract.</p> <p>C. On May 28, 2021, the City issued a Notice to Contractors inviting bids for the Project. A copy of the Contractor's Bid proposal and List of Subcontractors is attached herein and incorporated by this reference.</p> <p>D. The City desires to retain Contractor as an independent contractor to provide the construction and other services identified in this Contract for the Project upon the terms and conditions contained herein.</p>
<b>AGREEMENT</b>
<p>NOW, THEREFORE, in consideration of performance by the parties of the promises, covenants and conditions contained herein, the parties hereby agree as follows:</p> <p>1. DEFINITIONS. Capitalized terms used throughout the Contract Documents shall have the meanings set forth in this Contract and/or the Special Provisions. If there is a conflict between the definitions in this Contract and the Special Provisions, the definitions in this Contract shall prevail.</p> <p>2. PROJECT. The project is the construction of Sharon Park Walkways Reconstruction Project ("Project"). The work includes all labor, materials, equipment, services, permits, licenses and taxes, and all other things necessary for Contractor to perform its obligations and complete the Project, including, without limitation, any Change Orders executed by City and Contractor in accordance with the requirements of the Contract Documents ("Work").</p> <p>3. CONTRACT DOCUMENTS.</p> <p>3.1 List of Documents. The Contract Documents (sometimes collectively referred to as "Agreement" or "Bid Documents") consist of the following documents which are on file with the Public Works Department and are hereby incorporated by reference.</p> <p>1) Change Orders 2) Field Orders</p>

- 3) Contract
- 4) Bidding Addenda
- 5) Special Provisions
- 6) Project Plans and Drawings
- 7) Technical Specifications
- 8) City Standard Details
- 9) State of California Department of Transportation Specifications, 2006 Edition (Cal Trans specifications)
- 10) Notice to Contractors
- 11) Contractor's Bid
- 12 Bidder Certifications, Questionnaire and Statements
- 13) Reports listed in the Contract Documents
- 14) City of Menlo Park Waste Management Form, Waste Management Daily Transport Report
- 15) City of Menlo Park Truck Route Map and Regulations
- 16) Performance, Payment and Maintenance Bonds

3.2 Order of Precedence. For the purposes of construing, interpreting and resolving inconsistencies between and among the provisions of this Contract, the Contract Documents shall have the order of precedence as set forth in the preceding section. If a claimed inconsistency cannot be resolved through the order of precedence, the City shall have the sole power to decide which document or provision shall govern as may be in the best interests of the City.

4. PERMITS. Contractor, at its sole expense, shall obtain and maintain during the term of this Contract, all appropriate permits, licenses and certificates that may be required in connection with the performance of the Work, including, but not limited to, a City business license.

5. DEPARTMENT OF INDUSTRIAL RELATIONS. Contractor and any subcontractor performing Work on this Project shall be registered with the Department of Industrial Relations ("DIR") pursuant to Labor Code Section 1725.5. No contractor or subcontractor may be listed on a bid proposal for a public works project unless registered with the DIR pursuant to Labor Code Section 1725.5, with limited exceptions from this requirement for bid purposes only under Labor Code Section 1771.1(a). This Project is subject to compliance monitoring and enforcement by the DIR. It is the responsibility of the Contractor to ensure all DIR requirements and regulations are met and stay current. For more information, see <http://dir.ca.gov/Public-Works/SB854.html>.

6. TERM. This Contract is effective on the Execution Date set forth in the initial paragraph of this Contract and shall remain in effect until the Project has been satisfactorily completed by Contractor, unless earlier terminated pursuant to the terms of this Contract.

7. TIME OF COMPLETION. Time is of the essence with respect to all time limits set forth in the Contract Documents. Contractor shall commence the Work on the date specified in the City's Notice to Proceed. Contractor shall diligently prosecute the Work to Substantial Completion within twenty-five (25) working days after the date specified in the City's Notice to Proceed ("Contract Time"). The Contract Time may only be adjusted for extensions of time approved by the City and agreed to by Change Order executed by City and Contractor in accordance with the requirements of the Contract Documents.

8. COMPENSATION. The City agrees to compensate Contractor for its satisfactory completion of the Work in compliance with the Contract Documents for the not to exceed amount of Three Hundred Forty Three Thousand Three Hundred Eighty (\$343,380) ("Contract Sum"). Payment shall be as set forth in the Plans, Special Provisions and/or Technical Specifications. The Contract Sum may only be adjusted

by Change Orders issued, executed and satisfactorily performed by Contractor in accordance with the requirements of the Contract Documents. The Contract Sum shall be adjusted (upward or downward) only to account for Change Orders. The Contract Sum is and shall be full compensation for all Work performed by Contractor. The Contract Sum shall cover all losses arising out of the nature of the Work or from the elements or any unforeseen difficulties or obstructions which may arise or be encountered in performance of the Work until its Acceptance by the City, all risks connected with the Work and any and all expenses incurred due to the suspension or discontinuance of the Work.

9. STANDARD OF PERFORMANCE. As a material inducement to the City to enter into this Contract, Contractor hereby represents and warrants that it has the qualifications and experience necessary to undertake the Work to be provided and the Project to be completed pursuant to this Contract. Contractor agrees that the Work shall be performed by qualified, experienced and well-supervised personnel. The Work performed pursuant to this Contract shall be performed in a manner consistent with the standard of care under California law applicable to those who specialize in providing such services for projects of the type, scope and complexity of the Project.

10. COMPLIANCE WITH LAW. This Project constitutes a public work within the meaning of California Labor Code Section 1720 et. seq. and is subject to prevailing wage laws. The Work performed by Contractor pursuant to this Contract shall be provided in accordance with all ordinances, resolutions, statutes, rules and regulations of the City, and any federal, state or local governmental agency having jurisdiction in effect at the time the work is rendered.

11. REPRESENTATIVE. \_\_\_\_\_ is hereby designated as the project manager/superintendent/foreman of Contractor authorized to act on its behalf with respect to the Work specified in this Contract. It is expressly understood that the experience, knowledge, capability and reputation of Terramark General Engineering Contractors Inc. were a substantial inducement for City to enter into this Contract. Therefore, \_\_\_\_\_ shall be responsible during the term of this Contract for directing all activities of Contractor and devoting sufficient time to personally supervise the services hereunder. The representative may not be changed by Contractor without the express written approval of the City.

## 12. LIQUIDATED DAMAGES.

12.1 Entitlement. City and Contractor acknowledge and agree that if Contractor fails to fully and satisfactorily complete the Work within the Contract Time, the City will suffer, as a result of Contractor's failure, substantial damages which are both extremely difficult and impracticable to ascertain. Such damages may include, but are not limited to: (a) loss of public confidence in the City and its contractors; (b) loss of public use of public facilities; and (c) extended disruption to public.

12.2 Daily Amount. City and Contractor have reasonably endeavored, but failed, to ascertain the actual damage that the City will incur if the Contractor fails to achieve Substantial Completion of the Work within the Contract Time. Therefore, the parties agree that in addition to all other damages to which the City may be entitled other than delay damages, in the event the Contractor shall fail to achieve Substantial Completion of the Work within the Contract Time, Contractor shall pay City as liquidated damages the amount of five hundred Dollars (\$500) per day for each calendar day after the expiration of the Contract Time until Contractor achieves Substantial Completion of the Work. The liquidated damages amount is not a penalty, but a reasonable estimate of the amount of damages the City will suffer.

12.3 Apportionment. Such liquidated damages shall be subject to reduction for delays for which Contractor is entitled to receive an extension of time under the Contract Documents ("Apportionment").

Such Apportionment shall not be affected by the fact that liquidated damages may not be applied for periods of time during which delays have occurred that are caused by both City and Contractor. It is agreed that the liquidated damages shall not be applied for portions of the Work completed prior to the expiration of the Contract Time.

12.4 Exclusive Remedy. City and Contractor acknowledge and agree that this Section 11, Liquidated Damages, shall be the City's only remedy for delay damages caused by the Contractor's failure to achieve Substantial Completion of the Work within the Contract Time.

12.5 Damages upon Abandonment. In the event that the Contractor either abandons the Work or is terminated for default in accordance with the provisions of this Contract, City shall have the right, in its sole discretion exercised by written notice issued either before or after Substantial Completion, to elect to either assert or waive its right to liquidated damages. If City elects to assert its right to liquidated damages, then the liquidated damages shall be calculated from expiration of the Contract Time to the date that Substantial Completion of the Work is achieved by the City or its replacement contractor employed to complete Contractor's performance. If City elects to waive its right to liquidated damages, then Contractor shall be liable to the City, in lieu of the liquidated damages, for all actual Losses (as defined in the General Conditions) proximately resulting from Contractor's failure to complete the Work within the Contract Time.

12.6 Other Remedies. The parties further acknowledge and agree that the City is entitled to any and all available legal and equitable remedies City may have where City's Losses are caused by any reason other than Contractor's failure to achieve Substantial Completion of the Work within the Contract Time.

13. INDEPENDENT CONTRACTOR. Contractor is, and shall at all times remain as to the City, a wholly independent contractor and not an agent or employee of the City. Contractor shall receive no premium or enhanced pay for work normally understood as overtime, nor shall Contractor receive holiday pay, sick leave, administrative leave, or pay for any other time not actually worked. The intention of the parties is that Contractor shall not be eligible for benefits and shall receive no compensation from the City except as expressly set forth in this Contract. Contractor shall have no power to incur any debt, obligation, or liability on behalf of the City or otherwise act on behalf of the City as an agent. Neither the City, nor any of its agents shall have control over the conduct of Contractor, any of Contractor's employees, or any subcontractors, except as set forth in this Contract. Contractor shall at no time, or in any manner, represent that it or any of its agents or employees or subcontractors are in any manner employees of the City. Contractor agrees to pay all required taxes on amounts paid to Contractor under this Contract, and to indemnify and hold the City harmless from any and all taxes, assessments, penalties, and interest asserted against the City by reason of the independent contractor relationship created by this Contract. Contractor shall fully comply with the worker's compensation law regarding Contractor, Contractor's employees and subconsultants. Contractor further agrees to indemnify and hold the City harmless from any failure of Contractor and any subconsultants to comply with applicable worker's compensation laws.

14. CONFLICT OF INTEREST. Contractor covenants that it presently has no interest and shall not acquire any interest, direct or indirect, which may be affected by the work to be performed by Consultant under this Contract, or which would conflict in any manner with the performance of its services hereunder. Contractor further covenants that, in performance of this Contract, no person having any such interest shall be employed by it. Furthermore, Contractor shall avoid the appearance of having any interest which would conflict in any manner with the performance of the work pursuant to this Contract. Contractor agrees not to accept any employment during the term of this Contract which is or may make Contractor financially interested, as provided in California Government Code Sections 1090 and 87100, in any decision made by the City on any matter in connection with which Contractor has

been retained pursuant to this Contract. However, nothing herein shall preclude Contractor from accepting other engagements with the City.

#### 15. INDEMNIFICATION.

15.1 To the fullest extent permitted by law, Contractor shall indemnify, defend, with independent counsel approved by the City, and hold harmless the City, and its elective or appointive boards, officers, employees agents and volunteers ("Indemnitee") from and against any and all claims, losses, or liability that may arise out of or result from damages to property or personal injury received by reason of, or in the course of work performed under this Contract due to the acts or omissions of Contractor or Contractor's officers, employees, agents or subcontractors. The indemnification provisions survive completion of the Work or the termination of this Contract. The acceptance of such services shall not operate as a waiver of such right of indemnification. Notwithstanding the foregoing, nothing contained herein shall be construed as obligating Contractor to indemnify any Indemnitee for any claims, losses or liability resulting from the sole or active negligence or willful misconduct of the Indemnitee. Contractor shall pay City for any costs incurred in enforcing this provision.

15.2 The City does not and shall not waive any rights that they may possess against Contractor because of the acceptance by the City or the deposit with the City of any insurance policy or certificate required pursuant to this Contract. This hold harmless and indemnification provision shall apply regardless of whether or not any insurance policies are determined to be applicable to the claim, demand, damage, liability, loss, cost or expense.

15.3 Pursuant to Public Contract Code Section 9201, the City shall timely notify Contractor upon receipt of any third-party claim relating to the Contract.

16. ASSIGNABILITY. The parties agree that the experience and qualifications of Contractor as set forth in the Contractor's Bid are material considerations for the City entering into this Contract. Consultant shall not assign or transfer any interest in this Contract, without the prior written consent of the City, and any attempt by Contractor to do so shall be void and of no effect and a breach of this Contract. For purposes of this section, the sale, assignment, transfer or other disposition of any of the issued and outstanding capital stock of Contractor or of any general partner or joint venturer or syndicate member of Contractor, if a partnership or joint venture or syndicate or co-tenancy exists, which shall result in changing the control of Contractor, shall be construed as an assignment of this Construction Contract. Control means more than fifty percent (50%) of the voting power of the corporation or other entity.

#### 17. INSURANCE AND BOND REQUIREMENTS.

17.1 Prior to the commencement of any Work, the Contractor shall provide the City with evidence that it has obtained the insurance required by this Section and all bonds, including, but not limited to, payment and performance bonds, required in the Special Provisions. Failure to obtain and maintain the required insurance and bonds to so shall be deemed a material breach of this Contract.

17.2 Insurance Requirements. Contractor shall obtain the following insurance.

A. Worker's Compensation and Employer's Liability Insurance: The CONTRACTOR shall have in effect during the entire life of this Contract workers' compensation and Employer's Liability Insurance providing full statutory coverage. In signing this Contract, the CONTRACTOR makes the following certification, required by Section 18161 of the California Labor Code: "I am aware of the provisions of Section 3700 of the California Labor Code which require every employer to be insured against liability for workers' compensation or to undertake self-insurance in accordance with the provisions of the Code, and I will

comply with such provisions before commencing the performance of the work of this Contract."

B. Commercial General Liability Insurance: The CONTRACTOR shall take out and maintain during the life of this Contract such Bodily Injury Liability and Property Damage Liability Insurance (Commercial General Liability Insurance) on an occurrence basis as shall protect it while performing work covered by this Contract from any and all claims for damages for bodily injury, including accidental death, as well as claims for property damage which may arise from the CONTRACTOR's operations under this Contract, whether such operations be by CONTRACTOR or by any sub-consultant or by anyone directly or indirectly employed by either of them. The amounts of such insurance shall be not less than two million dollars (\$2,000,000) per occurrence and four million dollars (\$4,000,000) in aggregate, or four million dollars (\$4,000,000) combined single limit bodily injury and property damage for each occurrence. CONTRACTOR shall provide the City with acceptable evidence of coverage, including a copy of all declarations of coverage exclusions.

C. Automobile Liability Insurance: CONTRACTOR shall maintain Automobile Liability Insurance pursuant to this Contract in an amount of not less than one million dollars (\$1,000,000) for each accident combined single limit or not less than one million dollars (\$1,000,000) for any one (1) person, and one million dollars (\$1,000,000) for any one (1) accident, and Three Hundred Thousand Dollars, (\$300,000) property damage.

17.3 CITY and its subsidiary agencies, and their officers, agents, employees and servants shall be named as additional insured on any such policies of Commercial General Liability and Automobile Liability Insurance, (but not for the workers' compensation), which shall also contain a provision that the insurance afforded thereby to the CITY, its subsidiary agencies, and their officers, agents, employees, and servants shall be primary insurance to the full limits of liability of the policy, and that if the CITY, its subsidiary agencies and their officers and employees have other insurance against a loss covered by a policy, such other insurance shall be excess insurance only.

17.4 In the event of the breach of any provision of this Section, or in the event any notice is received which indicates any required insurance coverage will be diminished or canceled, CITY, at its option, may, notwithstanding any other provision of this Contract to the contrary, immediately declare a material breach of this Contract and suspend all further work pursuant to this Contract.

17.5. Before the execution of this Contract, any deductibles or self-insured retentions must be declared to and approved by CITY.

18. SUSPENSION. The City may, at any time and from time to time, without cause, order Contractor, in writing ("Suspension Order"), to suspend, delay, or interrupt the Work in whole or in part for such period of time, up to an aggregate of fifty percent (50%) of the Contract Time, as City may determine, with such period of suspension to be computed from the date of the Suspension Order. Upon receipt of a Suspension Order, Contractor shall, at City's expense, comply with its terms and take all reasonable steps to minimize costs allocable to the Work covered by the Suspension Order during the period of work stoppage. Within the period of the above noted aggregate time, or such extension to that period as is agreed upon by Contractor and City, City shall either cancel the Suspension Order or delete the work covered by the Suspension Order by issuing a Change Order. If a Suspension Order is canceled or expires, Contractor shall resume and continue with the Work. A Change Order will be issued to cover any adjustments of the Contract Sum or the Contract Time necessarily caused by such suspension.

19. BOOKS AND RECORDS. Contractor shall keep full and detailed accounts and exercise such controls as may be necessary for proper financial management under this Contract in accordance with generally accepted accounting principles and practices consistently applied. City and City's accountants

shall be afforded access at all times during normal business hours, to inspect, audit and copy Contractor's records, books, estimates, take-offs, cost reports, ledgers, schedules, correspondence, instructions, drawings, receipts, subcontracts, purchase orders, vouchers, memoranda and other data relating to this Project, and Contractor shall preserve these for a period of three years after the later of (i) final payment or (ii) final resolution of all Contract Disputes and other disputes or for such longer period as may be required by law. Contractor's compliance with any request by City pursuant to this Section 18 shall be a condition precedent to filing or maintenance of any legal action or proceeding by Contractor against City and to Contractor's right to receive further payments under the Contract Documents. Any failure by Contractor to provide access to its business records for inspection or copying by City shall be specifically enforceable by issuance of a writ or a provisional or permanent mandatory injunction by a court of competent jurisdiction based on affidavits submitted to such court, without the necessity of oral testimony.

20. WAIVER. Waiver by either party of any breach or violation of any one or more terms or conditions of this Contract shall not be deemed to be a waiver of any other term or condition contained herein or a waiver of any subsequent breach or violation of the same or any other term or condition. Acceptance by the City of the performance of any work by the Contractor shall not be deemed to be a waiver of any term or condition of this Contract. In no event shall the City's making of any payment to Contractor constitute or be construed as a waiver by the City of any breach of this Contract, or any default which may then exist on the part of Contractor, and the making of any such payment by the City shall in no way impair or prejudice any right or remedy available to the City with regard to such breach or default.

21. DEFAULT. In the event the City determines, in its sole discretion, that Contractor has failed or refused to perform any of the obligations set forth in the Contract Documents, or is in breach of any provision of the Contract Documents, the City may give written notice of default to Contractor in the manner specified for this giving of notices in this Contract. Except for emergencies, Contractor shall cure any default in performance of its obligations under the Contract Documents within two (2) business days after receipt of written notice. However, if the breach cannot be reasonably cured within such time, Contractor will commence to cure the breach within two (2) days and will diligently and continuously prosecute such cure to completion within a reasonable time, which shall in no event be later than ten (10) days after receipt of such written notice.

## 22. CITY RIGHTS AND REMEDIES.

22.1 Remedies Upon Default. In the event that Contractor fails to cure any default of this Contract within the time period set forth in Section 20, then City may pursue any remedies available under law or equity, including, without limitation, the following: (1) the City may, without terminating the Contract, delete certain portions of the Work, reserving to itself all rights to losses related thereto; (2) the City may, without terminating the Contract, engage others to perform the Work or portion of the Work that has not been performed by the Contractor and withhold the cost thereof to City from future payments to the Contractor, reserving to itself all rights to Losses related thereto; or (3) the City may, without terminating the Contract and reserving to itself all rights to Losses related thereto, suspend all or any portion of this Construction Contract for as long a period of time as City determines, in its sole discretion, appropriate, in which event City shall have no obligation to adjust the Contract Sum or Contract Time, and shall have no liability to Contractor for damages if City directs Contractor to resume Work; (4) the City may terminate all or any part of this Contract for default, reserving to itself all rights of Losses related thereto; or (5) the City may, without terminating the Contract and reserving to itself all rights to Losses related thereto, exercise its rights under the Performance Bond.

22.2 Additional Provisions. All of City's rights and remedies under this Contract are cumulative, and shall be in addition to those rights and remedies available in law or in equity. Designation in the

Contract Documents of certain breaches as material shall not be construed as implying that other breaches not so designated are not material nor shall such designations be construed as limiting City's right to terminate the Contract, or the exercise of its other rights or remedies for default, to only material breaches. City's determination of whether there has been noncompliance with the Contract so as to warrant exercise by City of its rights and remedies for default under the Contract, shall be binding on all parties. No termination or action taken by City after such termination shall prejudice any other rights or remedies of City provided by law or equity or by the Contract Documents upon such termination; and City may proceed against Contractor to recover all liquidated damages and Losses suffered by City.

22.3 Delays by Sureties. Without limitation to any of City's other rights or remedies under the law, City has the right to suspend the performance by Contractor's sureties in the event of any of the following: (1) failure of the sureties to begin Work within a reasonable time in such manner as to insure full compliance with the Contract within the Contract Time; (2) abandonment of the Work; (3) if at any time City is of the opinion the Work is unnecessarily or unreasonably delayed; (4) willful violation of any terms of the Contract; (5) failure to perform according to the Contract Documents; or (6) failure to follow instructions of City for its completion within the Contract Time. City will serve notice of such failure upon the sureties and in the event the sureties neglect or refuse to cure the breach within the time specified in such notice, City shall have the power to suspend the performance or any part thereof of the sureties.

22.4 Damages to the City. The City will be entitled to recovery of all Losses under law or equity in the event of Contractor's default under the Contract Documents. In the event that City's Losses arise from Contractor's default under the Contract Documents, City shall be entitled to withhold monies otherwise payable to Contractor until Final Completion, as defined in the General Conditions, of the Project. If City incurs Losses due to Contractor's default, then the amount of Losses shall be deducted from the amounts withheld. Should the amount withheld exceed the amount deducted, the balance will be paid to Contractor or its designee upon Final Completion of the Project. If the Losses incurred by City exceed the amount withheld, Contractor shall be liable to City for the difference and shall promptly remit same to City.

22.5 Termination of the Contract for Default. Without limitation to any of City's other rights or remedies at law or in equity, and reserving to itself all rights to Losses related thereto, City shall have the right to terminate this Contract, in whole or in part, upon the failure of Contractor to promptly cure any default. City's election to terminate the Contract for default shall be communicated by giving Contractor a written notice of termination in the manner specified for the giving of notices in the Contract. Any notice of termination given to Contractor by City shall be effective immediately, unless otherwise provided therein.

22.6 Termination Without Cause. City shall have the option, at its sole discretion and without cause, of terminating this Contract in part or in whole by giving thirty (30) days written notice to Contractor. Contractor agrees to accept such sums as allowed under this Section as its sole and exclusive compensation and waives any claim for other compensation or Losses, including, but not limited to, loss of anticipated profits, loss of revenue, lost opportunity, or other consequential, direct, indirect or incidental damages of any kind.

22.7 Compensation. Following termination without cause and within forty-five (45) days after receipt of a billing from Contractor seeking payment of sums authorized by this Section, City shall pay to Contractor as its sole compensation for performance of the Work the following: (1) the amount of the Contract Sum allocable to the portion of the Work properly performed by Contractor as of the date of termination, less sums previously paid to Contractor; (2) reasonable costs of Contractor and its Subcontractors and Sub-subcontractors for demobilizing and administering the close-out of its participation in the Project (including, without limitation, all billing and accounting functions, not including



attorney or expert fees) for a period of no longer than thirty (30) days after receipt of the notice of termination in an amount not to exceed the daily sum payable to Contractor for Compensable Delays; (3) previously unpaid cost of any items delivered to the Project Site which were fabricated for subsequent incorporation in the Work.

22.8 Subcontractors. Contractor shall include provisions in all of its subcontracts, purchase orders and other contracts permitting termination for convenience by Contractor on terms that are consistent with this Contract and that afford no greater rights of recovery against Contractor than are afforded to Contractor under this Section.

22.9 Contractor's Duties Upon Termination. Upon receipt of a notice of termination for default or for convenience, Contractor shall, unless the notice directs otherwise, do the following: (1) immediately discontinue the Work to the extent specified in the notice; (2) place no further orders or subcontracts for materials, equipment, services or facilities, except as may be necessary for completion of such portion of the Work as is not discontinued; (3) provide to City a description, in writing no later than fifteen (15) days after receipt of the notice of termination, of all subcontracts, purchase orders and contracts that are outstanding, including, without limitation, the terms of the original price, any changes, payments, balance owing, the status of the portion of the Work covered and a copy of the subcontract, purchase order or contract and any written changes, amendments or modifications thereto, together with such other information as City may determine necessary in order to decide whether to accept assignment of or request Contractor to terminate the subcontract, purchase order or contract; (4) promptly assign to City those subcontracts, purchase orders or contracts, or portions thereof, that City elects to accept by assignment and cancel, on the most favorable terms reasonably possible, all subcontracts, purchase orders or contracts, or portions thereof, that City does not elect to accept by assignment; and (5) hereafter do only such Work as may be necessary to preserve and protect Work already in progress and to protect materials, plants, and equipment on the Project Site or in transit thereto.

23. CONTRACTOR'S RIGHTS AND REMEDIES. Contractor may terminate this Construction Contract for cause only upon the occurrence of one of the following: (1) the Work is stopped for sixty (60) consecutive days, through no act or fault of Contractor, any subcontractor or any employee or agent of Contractor or any subcontractor, due to issuance of an order of a court or other public authority other than City having jurisdiction or due to an act of government, such as a declaration of a national emergency making material unavailable; or (2) if the City does not make payment of sums that are not in good faith disputed by the City and does not cure such default within ninety (90) days after receipt of notice from Contractor, then upon an additional thirty (30) days' notice to City, Contractor may terminate the Contract.

23.1 Damages to Contractor. In the event of termination for cause by Contractor, City shall pay Contractor the sums provided for in Section 21 above. Contractor agrees to accept such sums as its sole and exclusive compensation and agrees to waive any claim for other compensation or Losses, including, but not limited to, loss of anticipated profits, loss of revenue, lost opportunity, or other consequential, direct, indirect and incidental damages, of any kind.

24. NOTICES. Any notices or other communications required or permitted to be given under this Contract shall be given in writing by personal delivery, by a recognized courier service, or by U.S. mail, postage prepaid, and return receipt requested, addressed to the respective parties as follows:

To City:

Assistant Public Works Director/City Engineer  
City of Menlo Park  
City Hall, 701 Laurel St.  
Menlo Park, CA 94025

To Contractor:

Terramark General Engineering  
Contractors, Inc.  
PO Box 22089  
San Jose, CA 95151

25. Notice shall be deemed communicated on the earlier of actual receipt or 48 hours after deposit in the U.S. mail, or the date of delivery shown on deliverer's receipt. In the event of any change of address, the moving party is obligated to notify the other party of the change of address in writing within a reasonable period of time.

In addition, copies of all Claims by Contractor under this contract shall be provided to the City Attorney as follows:

To City Attorney:

City Attorney  
Burke, Williams & Sorensen, LLP  
181 Third Street, Suite 200  
San Rafael, CA 94901

All claims shall be delivered personally or sent by certified mail.

26. NON-DISCRIMINATION AND EQUAL EMPLOYMENT OPPORTUNITY. In the performance of this Contract, Contractor shall not discriminate against any employee, subcontractor or applicant for employment because of race, color, creed, religion, sex, marital status, sexual orientation, national origin, ancestry, age, physical or mental handicap, or medical condition. Contractor will take affirmative action to ensure that employees are treated without regard to race, color, creed, religion, sex, marital status, sexual orientation, national origin, ancestry, age, physical or mental handicap, or medical condition.

27. CONTRACT DOCUMENTS AND PRECEDENCE. The Contract Documents shall consist of the following documents. In case of inconsistencies between Contract Documents, the documents are listed in order of precedence.

28. PUBLIC WORKS CLAIMS. This Contract is subject to Public Contracts Code Section 9204 governing contractor claims.

29. ATTORNEYS' FEES; VENUE. In the event that any party to this Contract commences any legal action or proceeding to enforce or interpret the provisions of this Contract, the prevailing party in such action or proceeding shall be entitled to recover reasonable attorneys' fees and other costs incurred in that action or proceeding, in addition to any other relief to which the successful party may be entitled. The venue for any litigation shall be San Mateo County.

30. COOPERATION. In the event any claim or action is brought against the City relating to Contractor's performance or services under this Agreement, Contractor shall render any reasonable assistance and cooperation which City might require.

31. NUISANCE. Contractor shall not maintain, commit, nor permit the maintenance or commission of any nuisance in connection with the performance of services under this Contract.

32. GOVERNING LAW. This Contract shall be construed in accordance with and governed by the laws of the State of California.

33. COMPLETE AGREEMENT; SEVERABILITY. This Contract, and any other documents incorporated herein by reference, represent the entire and integrated agreement between the City and Contractor. This Contract supersedes all prior oral and written negotiations, representations or agreements. No prior oral or written understanding shall be of any force or effect with respect to those matters covered hereunder. This Contract may only be modified by a written amendment duly executed by the parties to this Contract. In case a provision of this Contract is held to be invalid, illegal or unenforceable, the validity, legality and enforceability of the remaining provisions shall not be affected.

34. COUNTERPARTS. This Contract may be signed in multiple counterparts, which shall, when executed by all the parties constitute a single binding contract.

SIGNATURE PAGE TO FOLLOW

IN WITNESS WHEREOF, the parties hereto have executed this agreement on the day and year first above written.

**FOR FIRST PARTY:**

\_\_\_\_\_  
Signature

\_\_\_\_\_  
Date

\_\_\_\_\_  
Printed name

\_\_\_\_\_  
Title

\_\_\_\_\_  
Tax ID#

**APPROVED AS TO FORM:**

\_\_\_\_\_  
Nira F. Doherty, City Attorney

\_\_\_\_\_  
Date

**FOR CITY OF MENLO PARK:**

\_\_\_\_\_  
Starla Jerome-Robinson, City Manager

\_\_\_\_\_  
Date

**ATTEST:**

\_\_\_\_\_  
Judi A. Herren, City Clerk

\_\_\_\_\_  
Date



## STAFF REPORT

### City Council

Meeting Date:

8/17/2021

Staff Report Number:

21-152-CC

Consent Calendar:

**Award a construction contract to Tricon  
Construction for the Burgess Pool chemical room  
renovation**

### Recommendation

Staff recommends that the City Council award a construction contract (Attachment A) to Tricon Construction Company for \$129,641 and approve 15 percent construction contingency of \$19,446 (held by the City) for an aggregate not to exceed amount of \$165,000 for the Burgess pool chemical room renovation project.

### Policy Issues

City Council authorization of this construction agreement is required as the agreement amount exceeds the city manager's expenditure authority.

### Background

The existing Burgess Pool chemical room has been used without upgrades for the last 16 years. This renovation project was identified seven years ago to make the chemical room safer. The existing system is an antiquated system. The system is no longer used in aquatic facilities in general. The chemical room itself is becoming corroded from the chemicals, which can cause structural damage in the future if not addressed.

### Analysis

On May 17, 2021, the project request for proposal invited all interested contractors to bid on the project. The scope of work included replacing the pool's pH system, converting from hydrochloric acid to CO<sub>2</sub>, repairing and/or replacing mechanical room and chemical room elements impacted by corrosion such as doors, hardware, roof and structural elements and providing all specified labor, materials, equipment and furnishings.

On June 7, 2021, the City received one proposal per Table 1. The cost is higher than we would have expected for the scope of the work, but that due to limited contractor availability the resulting bid is the best available price. Due to the need to complete this work, and the fact that we do not expect availability (or pricing) to change in the near future, we recommend proceeding with this contract/bid.

Contractors	Bid amount
Tricon Construction	\$129,641

**Impact of City**

This project is funded in the City’s five year capital improvement program (CIP) as part of the aquatics center maintenance programmatic category. The available balance is \$1,400,000. The estimated construction cost will not exceed \$165,000 per Table 2.

Items	Amount
Contractor proposal amount	\$129,641
Contingency (15%)	\$19,446
Construction administration	\$15,913
Total cost of recommendation	\$165,000

**Environmental Review**

This project is categorically exempt pursuant to California Environmental Quality Act (CEQA) Guidelines §§ 15301(d) replacement of existing facilities.

**Public Notice**

Public notification was achieved by posting the agenda, with the agenda items being listed, at least 72 hours prior to the meeting.

**Attachments**

- A. Construction contract

Report prepared by:  
 Arian Khosravian, Project Manager

Report reviewed by:  
 Karen Pachmayer, Interim Assistant Public Works Director

**CONSTRUCTION AGREEMENT**

City Manager's Office  
701 Laurel St., Menlo Park, CA 94025  
tel 650-330-6620



<b>Agreement #:</b>
<b>AGREEMENT FOR SERVICES BETWEEN THE CITY OF MENLO PARK AND TRICON AQUATICS CONSTRUCTION, INC.</b>
THIS CONSTRUCTION CONTRACT ("Contract") is made and entered into this _____ ("Execution Date") by and between the CITY OF MENLO PARK, a California municipal corporation, ("City") and TRICON AQUATICS CONSTRUCTION, INC. ("Contractor").
<b>RECITALS</b>
<p>A. Contractor is a <u>California Corporation</u> duly organized and in good standing in the State of California, License Number <u>1000000528</u>. Contractor represents and warrants that it has the background and experience set forth in the Contractor's responses to the notice inviting bids.</p> <p>B. Contractor represents that it is duly licensed by the State of California and has the background, knowledge, experience and expertise to perform the obligations set forth in this Contract.</p> <p>C. On <u>May 17, 2021</u>, the City issued a Notice to Contractors inviting bids for the Project. A copy of the Contractor's Bid proposal and List of Subcontractors is attached herein and incorporated by this reference.</p> <p>D. The City desires to retain Contractor as an independent contractor to provide the construction and other services identified in this Contract for the Project upon the terms and conditions contained herein.</p>
<b>AGREEMENT</b>
<p>NOW, THEREFORE, in consideration of performance by the parties of the promises, covenants and conditions contained herein, the parties hereby agree as follows:</p> <ol style="list-style-type: none"> <li>1. DEFINITIONS. Capitalized terms used throughout the Contract Documents shall have the meanings set forth in this Contract and/or the Special Provisions. If there is a conflict between the definitions in this Contract and the Special Provisions, the definitions in this Contract shall prevail.</li> <li>2. PROJECT. The project is the construction of <u>Burgess Pool Chemical Room Renovation project</u> ("Project"). The work includes all labor, materials, equipment, services, permits, licenses and taxes, and all other things necessary for Contractor to perform its obligations and complete the Project, including, without limitation, any Change Orders executed by City and Contractor in accordance with the requirements of the Contract Documents ("Work").</li> <li>3. CONTRACT DOCUMENTS. <ol style="list-style-type: none"> <li>3.1 List of Documents. The Contract Documents (sometimes collectively referred to as "Agreement" or "Bid Documents") consist of the following documents which are on file with the Public Works Department and are hereby incorporated by reference. <ol style="list-style-type: none"> <li>1) Change Orders</li> </ol> </li> </ol> </li> </ol>

- 2) Field Orders
- 3) Contract
- 4) Bidding Addenda
- 5) Special Provisions
- 6) Project Plans and Drawings
- 7) Technical Specifications
- 8) City Standard Details
- 9) State of California Department of Transportation Specifications, 2006 Edition (Cal Trans specifications)
- 10) Notice to Contractors
- 11) Contractor's Bid
- 12 Bidder Certifications, Questionnaire and Statements
- 13) Reports listed in the Contract Documents
- 14) City of Menlo Park Waste Management Form, Waste Management Daily Transport Report
- 15) City of Menlo Park Truck Route Map and Regulations
- 16) Performance, Payment and Maintenance Bonds

3.2 Order of Precedence. For the purposes of construing, interpreting and resolving inconsistencies between and among the provisions of this Contract, the Contract Documents shall have the order of precedence as set forth in the preceding section. If a claimed inconsistency cannot be resolved through the order of precedence, the City shall have the sole power to decide which document or provision shall govern as may be in the best interests of the City.

4. PERMITS. Contractor, at its sole expense, shall obtain and maintain during the term of this Contract, all appropriate permits, licenses and certificates that may be required in connection with the performance of the Work, including, but not limited to, a City business license.

5. DEPARTMENT OF INDUSTRIAL RELATIONS. Contractor and any subcontractor performing Work on this Project shall be registered with the Department of Industrial Relations ("DIR") pursuant to Labor Code Section 1725.5. No contractor or subcontractor may be listed on a bid proposal for a public works project unless registered with the DIR pursuant to Labor Code Section 1725.5, with limited exceptions from this requirement for bid purposes only under Labor Code Section 1771.1(a). This Project is subject to compliance monitoring and enforcement by the DIR. It is the responsibility of the Contractor to ensure all DIR requirements and regulations are met and stay current. For more information, see <http://dir.ca.gov/Public-Works/SB854.html>.

6. TERM. This Contract is effective on the Execution Date set forth in the initial paragraph of this Contract and shall remain in effect until the Project has been satisfactorily completed by Contractor, unless earlier terminated pursuant to the terms of this Contract.

7. TIME OF COMPLETION. Time is of the essence with respect to all time limits set forth in the Contract Documents. Contractor shall commence the Work on the date specified in the City's Notice to Proceed. Contractor shall diligently prosecute the Work to Substantial Completion within 90 calendar days after the date specified in the City's Notice to Proceed ("Contract Time"). The Contract Time may only be adjusted for extensions of time approved by the City and agreed to by Change Order executed by City and Contractor in accordance with the requirements of the Contract Documents.

8. COMPENSATION. The City agrees to compensate Contractor for its satisfactory completion of the Work in compliance with the Contract Documents for the not to exceed amount of One Hundred Twenty-Seven Thousand Seven Hundred Twenty-Five (\$127,725) ("Contract Sum"). Payment shall be as set forth in the Plans, Special Provisions and/or Technical Specifications. The Contract Sum may



only be adjusted by Change Orders issued, executed and satisfactorily performed by Contractor in accordance with the requirements of the Contract Documents. The Contract Sum shall be adjusted (upward or downward) only to account for Change Orders. The Contract Sum is and shall be full compensation for all Work performed by Contractor. The Contract Sum shall cover all losses arising out of the nature of the Work or from the elements or any unforeseen difficulties or obstructions which may arise or be encountered in performance of the Work until its Acceptance by the City, all risks connected with the Work and any and all expenses incurred due to the suspension or discontinuance of the Work.

9. STANDARD OF PERFORMANCE. As a material inducement to the City to enter into this Contract, Contractor hereby represents and warrants that it has the qualifications and experience necessary to undertake the Work to be provided and the Project to be completed pursuant to this Contract. Contractor agrees that the Work shall be performed by qualified, experienced and well-supervised personnel. The Work performed pursuant to this Contract shall be performed in a manner consistent with the standard of care under California law applicable to those who specialize in providing such services for projects of the type, scope and complexity of the Project.

10. COMPLIANCE WITH LAW. This Project constitutes a public work within the meaning of California Labor Code Section 1720 et. seq. and is subject to prevailing wage laws. The Work performed by Contractor pursuant to this Contract shall be provided in accordance with all ordinances, resolutions, statutes, rules and regulations of the City, and any federal, state or local governmental agency having jurisdiction in effect at the time the work is rendered.

11. REPRESENTATIVE. Jonathan Peel is hereby designated as the project manager/superintendent/foreman of Contractor authorized to act on its behalf with respect to the Work specified in this Contract. It is expressly understood that the experience, knowledge, capability and reputation of Tricon Construction, Inc. were a substantial inducement for City to enter into this Contract. Therefore, Jonathan Peel shall be responsible during the term of this Contract for directing all activities of Contractor and devoting sufficient time to personally supervise the services hereunder. The representative may not be changed by Contractor without the express written approval of the City.

## 12. LIQUIDATED DAMAGES.

12.1 Entitlement. City and Contractor acknowledge and agree that if Contractor fails to fully and satisfactorily complete the Work within the Contract Time, the City will suffer, as a result of Contractor's failure, substantial damages which are both extremely difficult and impracticable to ascertain. Such damages may include, but are not limited to: (a) loss of public confidence in the City and its contractors; (b) loss of public use of public facilities; and (c) extended disruption to public.

12.2 Daily Amount. City and Contractor have reasonably endeavored, but failed, to ascertain the actual damage that the City will incur if the Contractor fails to achieve Substantial Completion of the Work within the Contract Time. Therefore, the parties agree that in addition to all other damages to which the City may be entitled other than delay damages, in the event the Contractor shall fail to achieve Substantial Completion of the Work within the Contract Time, Contractor shall pay City as liquidated damages the amount of Five Hundred Dollars (\$500) per day for each calendar day after the expiration of the Contract Time until Contractor achieves Substantial Completion of the Work. The liquidated damages amount is not a penalty, but a reasonable estimate of the amount of damages the City will suffer.

12.3 Apportionment. Such liquidated damages shall be subject to reduction for delays for which Contractor is entitled to receive an extension of time under the Contract Documents ("Apportionment"). Such Apportionment shall not be affected by the fact that liquidated damages may not be applied for

periods of time during which delays have occurred that are caused by both City and Contractor. It is agreed that the liquidated damages shall not be applied for portions of the Work completed prior to the expiration of the Contract Time.

12.4 Exclusive Remedy. City and Contractor acknowledge and agree that this Section 11, Liquidated Damages, shall be the City's only remedy for delay damages caused by the Contractor's failure to achieve Substantial Completion of the Work within the Contract Time.

12.5 Damages upon Abandonment. In the event that the Contractor either abandons the Work or is terminated for default in accordance with the provisions of this Contract, City shall have the right, in its sole discretion exercised by written notice issued either before or after Substantial Completion, to elect to either assert or waive its right to liquidated damages. If City elects to assert its right to liquidated damages, then the liquidated damages shall be calculated from expiration of the Contract Time to the date that Substantial Completion of the Work is achieved by the City or its replacement contractor employed to complete Contractor's performance. If City elects to waive its right to liquidated damages, then Contractor shall be liable to the City, in lieu of the liquidated damages, for all actual Losses (as defined in the General Conditions) proximately resulting from Contractor's failure to complete the Work within the Contract Time.

12.6 Other Remedies. The parties further acknowledge and agree that the City is entitled to any and all available legal and equitable remedies City may have where City's Losses are caused by any reason other than Contractor's failure to achieve Substantial Completion of the Work within the Contract Time.

13. INDEPENDENT CONTRACTOR. Contractor is, and shall at all times remain as to the City, a wholly independent contractor and not an agent or employee of the City. Contractor shall receive no premium or enhanced pay for work normally understood as overtime, nor shall Contractor receive holiday pay, sick leave, administrative leave, or pay for any other time not actually worked. The intention of the parties is that Contractor shall not be eligible for benefits and shall receive no compensation from the City except as expressly set forth in this Contract. Contractor shall have no power to incur any debt, obligation, or liability on behalf of the City or otherwise act on behalf of the City as an agent. Neither the City, nor any of its agents shall have control over the conduct of Contractor, any of Contractor's employees, or any subcontractors, except as set forth in this Contract. Contractor shall at no time, or in any manner, represent that it or any of its agents or employees or subcontractors are in any manner employees of the City. Contractor agrees to pay all required taxes on amounts paid to Contractor under this Contract, and to indemnify and hold the City harmless from any and all taxes, assessments, penalties, and interest asserted against the City by reason of the independent contractor relationship created by this Contract. Contractor shall fully comply with the worker's compensation law regarding Contractor, Contractor's employees and subconsultants. Contractor further agrees to indemnify and hold the City harmless from any failure of Contractor and any subconsultants to comply with applicable worker's compensation laws.

14. CONFLICT OF INTEREST. Contractor covenants that it presently has no interest and shall not acquire any interest, direct or indirect, which may be affected by the work to be performed by Consultant under this Contract, or which would conflict in any manner with the performance of its services hereunder. Contractor further covenants that, in performance of this Contract, no person having any such interest shall be employed by it. Furthermore, Contractor shall avoid the appearance of having any interest which would conflict in any manner with the performance of the work pursuant to this Contract. Contractor agrees not to accept any employment during the term of this Contract which is or may make Contractor financially interested, as provided in California Government Code Sections 1090 and 87100, in any decision made by the City on any matter in connection with which Contractor has been retained pursuant to this Contract. However, nothing herein shall preclude Contractor from

accepting other engagements with the City.

## 15. INDEMNIFICATION.

15.1 To the fullest extent permitted by law, Contractor shall indemnify, defend, with independent counsel approved by the City, and hold harmless the City, and its elective or appointive boards, officers, employees agents and volunteers ("Indemnitee") from and against any and all claims, losses, or liability that may arise out of or result from damages to property or personal injury received by reason of, or in the course of work performed under this Contract due to the acts or omissions of Contractor or Contractor's officers, employees, agents or subcontractors. The indemnification provisions survive completion of the Work or the termination of this Contract. The acceptance of such services shall not operate as a waiver of such right of indemnification. Notwithstanding the foregoing, nothing contained herein shall be construed as obligating Contractor to indemnify any Indemnitee for any claims, losses or liability resulting from the sole or active negligence or willful misconduct of the Indemnitee. Contractor shall pay City for any costs incurred in enforcing this provision.

15.2 The City does not and shall not waive any rights that they may possess against Contractor because of the acceptance by the City or the deposit with the City of any insurance policy or certificate required pursuant to this Contract. This hold harmless and indemnification provision shall apply regardless of whether or not any insurance policies are determined to be applicable to the claim, demand, damage, liability, loss, cost or expense.

15.3 Pursuant to Public Contract Code Section 9201, the City shall timely notify Contractor upon receipt of any third-party claim relating to the Contract.

16. ASSIGNABILITY. The parties agree that the experience and qualifications of Contractor as set forth in the Contractor's Bid are material considerations for the City entering into this Contract. Consultant shall not assign or transfer any interest in this Contract, without the prior written consent of the City, and any attempt by Contractor to do so shall be void and of no effect and a breach of this Contract. For purposes of this section, the sale, assignment, transfer or other disposition of any of the issued and outstanding capital stock of Contractor or of any general partner or joint venturer or syndicate member of Contractor, if a partnership or joint venture or syndicate or co-tenancy exists, which shall result in changing the control of Contractor, shall be construed as an assignment of this Construction Contract. Control means more than fifty percent (50%) of the voting power of the corporation or other entity.

## 17. INSURANCE AND BOND REQUIREMENTS.

17.1 Prior to the commencement of any Work, the Contractor shall provide the City with evidence that it has obtained the insurance required by this Section and all bonds, including, but not limited to, payment and performance bonds, required in the Special Provisions. Failure to obtain and maintain the required insurance and bonds to so shall be deemed a material breach of this Contract.

17.2 Insurance Requirements. Contractor shall obtain the following insurance.

A. Worker's Compensation and Employer's Liability Insurance: The CONTRACTOR shall have in effect during the entire life of this Contract workers' compensation and Employer's Liability Insurance providing full statutory coverage. In signing this Contract, the CONTRACTOR makes the following certification, required by Section 18161 of the California Labor Code: "I am aware of the provisions of Section 3700 of the California Labor Code which require every employer to be insured against liability for workers' compensation or to undertake self-insurance in accordance with the provisions of the Code, and I will comply with such provisions before commencing the performance of the work of this Contract."

B. Commercial General Liability Insurance: The CONTRACTOR shall take out and maintain during the life of this Contract such Bodily Injury Liability and Property Damage Liability Insurance (Commercial General Liability Insurance) on an occurrence basis as shall protect it while performing work covered by this Contract from any and all claims for damages for bodily injury, including accidental death, as well as claims for property damage which may arise from the CONTRACTOR's operations under this Contract, whether such operations be by CONTRACTOR or by any sub-consultant or by anyone directly or indirectly employed by either of them. The amounts of such insurance shall be not less than two million dollars (\$2,000,000) per occurrence and four million dollars (\$4,000,000) in aggregate, or four million dollars (\$4,000,000) combined single limit bodily injury and property damage for each occurrence. CONTRACTOR shall provide the City with acceptable evidence of coverage, including a copy of all declarations of coverage exclusions.

C. Automobile Liability Insurance: CONTRACTOR shall maintain Automobile Liability Insurance pursuant to this Contract in an amount of not less than one million dollars (\$1,000,000) for each accident combined single limit or not less than one million dollars (\$1,000,000) for any one (1) person, and one million dollars (\$1,000,000) for any one (1) accident, and Three Hundred Thousand Dollars, (\$300,000) property damage.

17.3 CITY and its subsidiary agencies, and their officers, agents, employees and servants shall be named as additional insured on any such policies of Commercial General Liability and Automobile Liability Insurance, (but not for the workers' compensation), which shall also contain a provision that the insurance afforded thereby to the CITY, its subsidiary agencies, and their officers, agents, employees, and servants shall be primary insurance to the full limits of liability of the policy, and that if the CITY, its subsidiary agencies and their officers and employees have other insurance against a loss covered by a policy, such other insurance shall be excess insurance only.

17.4 In the event of the breach of any provision of this Section, or in the event any notice is received which indicates any required insurance coverage will be diminished or canceled, CITY, at its option, may, notwithstanding any other provision of this Contract to the contrary, immediately declare a material breach of this Contract and suspend all further work pursuant to this Contract.

17.5. Before the execution of this Contract, any deductibles or self-insured retentions must be declared to and approved by CITY.

18. SUSPENSION. The City may, at any time and from time to time, without cause, order Contractor, in writing ("Suspension Order"), to suspend, delay, or interrupt the Work in whole or in part for such period of time, up to an aggregate of fifty percent (50%) of the Contract Time, as City may determine, with such period of suspension to be computed from the date of the Suspension Order. Upon receipt of a Suspension Order, Contractor shall, at City's expense, comply with its terms and take all reasonable steps to minimize costs allocable to the Work covered by the Suspension Order during the period of work stoppage. Within the period of the above noted aggregate time, or such extension to that period as is agreed upon by Contractor and City, City shall either cancel the Suspension Order or delete the work covered by the Suspension Order by issuing a Change Order. If a Suspension Order is canceled or expires, Contractor shall resume and continue with the Work. A Change Order will be issued to cover any adjustments of the Contract Sum or the Contract Time necessarily caused by such suspension.

19. BOOKS AND RECORDS. Contractor shall keep full and detailed accounts and exercise such controls as may be necessary for proper financial management under this Contract in accordance with generally accepted accounting principles and practices consistently applied. City and City's accountants shall be afforded access at all times during normal business hours, to inspect, audit and copy Contractor's records, books, estimates, take-offs, cost reports, ledgers, schedules, correspondence,

instructions, drawings, receipts, subcontracts, purchase orders, vouchers, memoranda and other data relating to this Project, and Contractor shall preserve these for a period of three years after the later of (i) final payment or (ii) final resolution of all Contract Disputes and other disputes or for such longer period as may be required by law. Contractor's compliance with any request by City pursuant to this Section 18 shall be a condition precedent to filing or maintenance of any legal action or proceeding by Contractor against City and to Contractor's right to receive further payments under the Contract Documents. Any failure by Contractor to provide access to its business records for inspection or copying by City shall be specifically enforceable by issuance of a writ or a provisional or permanent mandatory injunction by a court of competent jurisdiction based on affidavits submitted to such court, without the necessity of oral testimony.

20. WAIVER. Waiver by either party of any breach or violation of any one or more terms or conditions of this Contract shall not be deemed to be a waiver of any other term or condition contained herein or a waiver of any subsequent breach or violation of the same or any other term or condition. Acceptance by the City of the performance of any work by the Contractor shall not be deemed to be a waiver of any term or condition of this Contract. In no event shall the City's making of any payment to Contractor constitute or be construed as a waiver by the City of any breach of this Contract, or any default which may then exist on the part of Contractor, and the making of any such payment by the City shall in no way impair or prejudice any right or remedy available to the City with regard to such breach or default.

21. DEFAULT. In the event the City determines, in its sole discretion, that Contractor has failed or refused to perform any of the obligations set forth in the Contract Documents, or is in breach of any provision of the Contract Documents, the City may give written notice of default to Contractor in the manner specified for this giving of notices in this Contract. Except for emergencies, Contractor shall cure any default in performance of its obligations under the Contract Documents within two (2) business days after receipt of written notice. However, if the breach cannot be reasonably cured within such time, Contractor will commence to cure the breach within two (2) days and will diligently and continuously prosecute such cure to completion within a reasonable time, which shall in no event be later than ten (10) days after receipt of such written notice.

## 22. CITY RIGHTS AND REMEDIES.

22.1 Remedies Upon Default. In the event that Contractor fails to cure any default of this Contract within the time period set forth in Section 20, then City may pursue any remedies available under law or equity, including, without limitation, the following: (1) the City may, without terminating the Contract, delete certain portions of the Work, reserving to itself all rights to losses related thereto; (2) the City may, without terminating the Contract, engage others to perform the Work or portion of the Work that has not been performed by the Contractor and withhold the cost thereof to City from future payments to the Contractor, reserving to itself all rights to Losses related thereto; or (3) the City may, without terminating the Contract and reserving to itself all rights to Losses related thereto, suspend all or any portion of this Construction Contract for as long a period of time as City determines, in its sole discretion, appropriate, in which event City shall have no obligation to adjust the Contract Sum or Contract Time, and shall have no liability to Contractor for damages if City directs Contractor to resume Work; (4) the City may terminate all or any part of this Contract for default, reserving to itself all rights to Losses related thereto; or (5) the City may, without terminating the Contract and reserving to itself all rights to Losses related thereto, exercise its rights under the Performance Bond.

22.2 Additional Provisions. All of City's rights and remedies under this Contract are cumulative, and shall be in addition to those rights and remedies available in law or in equity. Designation in the Contract Documents of certain breaches as material shall not be construed as implying that other breaches not so designated are not material nor shall such designations be construed as limiting City's

right to terminate the Contract, or the exercise of its other rights or remedies for default, to only material breaches. City's determination of whether there has been noncompliance with the Contract so as to warrant exercise by City of its rights and remedies for default under the Contract, shall be binding on all parties. No termination or action taken by City after such termination shall prejudice any other rights or remedies of City provided by law or equity or by the Contract Documents upon such termination; and City may proceed against Contractor to recover all liquidated damages and Losses suffered by City.

22.3 Delays by Sureties. Without limitation to any of City's other rights or remedies under the law, City has the right to suspend the performance by Contractor's sureties in the event of any of the following: (1) failure of the sureties to begin Work within a reasonable time in such manner as to insure full compliance with the Contract within the Contract Time; (2) abandonment of the Work; (3) if at any time City is of the opinion the Work is unnecessarily or unreasonably delayed; (4) willful violation of any terms of the Contract; (5) failure to perform according to the Contract Documents; or (6) failure to follow instructions of City for its completion within the Contract Time. City will serve notice of such failure upon the sureties and in the event the sureties neglect or refuse to cure the breach within the time specified in such notice, City shall have the power to suspend the performance or any part thereof of the sureties.

22.4 Damages to the City. The City will be entitled to recovery of all Losses under law or equity in the event of Contractor's default under the Contract Documents. In the event that City's Losses arise from Contractor's default under the Contract Documents, City shall be entitled to withhold monies otherwise payable to Contractor until Final Completion, as defined in the General Conditions, of the Project. If City incurs Losses due to Contractor's default, then the amount of Losses shall be deducted from the amounts withheld. Should the amount withheld exceed the amount deducted, the balance will be paid to Contractor or its designee upon Final Completion of the Project. If the Losses incurred by City exceed the amount withheld, Contractor shall be liable to City for the difference and shall promptly remit same to City.

22.5 Termination of the Contract for Default. Without limitation to any of City's other rights or remedies at law or in equity, and reserving to itself all rights to Losses related thereto, City shall have the right to terminate this Contract, in whole or in part, upon the failure of Contractor to promptly cure any default. City's election to terminate the Contract for default shall be communicated by giving Contractor a written notice of termination in the manner specified for the giving of notices in the Contract. Any notice of termination given to Contractor by City shall be effective immediately, unless otherwise provided therein.

22.6 Termination Without Cause. City shall have the option, at its sole discretion and without cause, of terminating this Contract in part or in whole by giving thirty (30) days written notice to Contractor. Contractor agrees to accept such sums as allowed under this Section as its sole and exclusive compensation and waives any claim for other compensation or Losses, including, but not limited to, loss of anticipated profits, loss of revenue, lost opportunity, or other consequential, direct, indirect or incidental damages of any kind.

22.7 Compensation. Following termination without cause and within forty-five (45) days after receipt of a billing from Contractor seeking payment of sums authorized by this Section, City shall pay to Contractor as its sole compensation for performance of the Work the following: (1) the amount of the Contract Sum allocable to the portion of the Work properly performed by Contractor as of the date of termination, less sums previously paid to Contractor; (2) reasonable costs of Contractor and its Subcontractors and Sub-subcontractors for demobilizing and administering the close-out of its participation in the Project (including, without limitation, all billing and accounting functions, not including attorney or expert fees) for a period of no longer than thirty (30) days after receipt of the notice of termination in an amount not to exceed the daily sum payable to Contractor for Compensable Delays;

(3) previously unpaid cost of any items delivered to the Project Site which were fabricated for subsequent incorporation in the Work.

22.8 Subcontractors. Contractor shall include provisions in all of its subcontracts, purchase orders and other contracts permitting termination for convenience by Contractor on terms that are consistent with this Contract and that afford no greater rights of recovery against Contractor than are afforded to Contractor under this Section.

22.9 Contractor's Duties Upon Termination. Upon receipt of a notice of termination for default or for convenience, Contractor shall, unless the notice directs otherwise, do the following: (1) immediately discontinue the Work to the extent specified in the notice; (2) place no further orders or subcontracts for materials, equipment, services or facilities, except as may be necessary for completion of such portion of the Work as is not discontinued; (3) provide to City a description, in writing no later than fifteen (15) days after receipt of the notice of termination, of all subcontracts, purchase orders and contracts that are outstanding, including, without limitation, the terms of the original price, any changes, payments, balance owing, the status of the portion of the Work covered and a copy of the subcontract, purchase order or contract and any written changes, amendments or modifications thereto, together with such other information as City may determine necessary in order to decide whether to accept assignment of or request Contractor to terminate the subcontract, purchase order or contract; (4) promptly assign to City those subcontracts, purchase orders or contracts, or portions thereof, that City elects to accept by assignment and cancel, on the most favorable terms reasonably possible, all subcontracts, purchase orders or contracts, or portions thereof, that City does not elect to accept by assignment; and (5) hereafter do only such Work as may be necessary to preserve and protect Work already in progress and to protect materials, plants, and equipment on the Project Site or in transit thereto.

23. CONTRACTOR'S RIGHTS AND REMEDIES. Contractor may terminate this Construction Contract for cause only upon the occurrence of one of the following: (1) the Work is stopped for sixty (60) consecutive days, through no act or fault of Contractor, any subcontractor or any employee or agent of Contractor or any subcontractor, due to issuance of an order of a court or other public authority other than City having jurisdiction or due to an act of government, such as a declaration of a national emergency making material unavailable; or (2) if the City does not make payment of sums that are not in good faith disputed by the City and does not cure such default within ninety (90) days after receipt of notice from Contractor, then upon an additional thirty (30) days' notice to City, Contractor may terminate the Contract.

23.1 Damages to Contractor. In the event of termination for cause by Contractor, City shall pay Contractor the sums provided for in Section 21 above. Contractor agrees to accept such sums as its sole and exclusive compensation and agrees to waive any claim for other compensation or Losses, including, but not limited to, loss of anticipated profits, loss of revenue, lost opportunity, or other consequential, direct, indirect and incidental damages, of any kind.

24. NOTICES. Any notices or other communications required or permitted to be given under this Contract shall be given in writing by personal delivery, by a recognized courier service, or by U.S. mail, postage prepaid, and return receipt requested, addressed to the respective parties as follows:

To City:

Assistant Public Works Director/City Engineer  
City of Menlo Park  
City Hall, 701 Laurel St.  
Menlo Park, CA 94025

To Contractor:

Tricon Construction, Inc.  
11419 Sunrise Gold Circle, Suite 6  
Rancho Cordova, CA 95742

25. Notice shall be deemed communicated on the earlier of actual receipt or 48 hours after deposit in the U.S. mail, or the date of delivery shown on deliverer's receipt. In the event of any change of address, the moving party is obligated to notify the other party of the change of address in writing within a reasonable period of time.

In addition, copies of all Claims by Contractor under this contract shall be provided to the City Attorney as follows:

To City Attorney:

City Attorney  
Burke, Williams & Sorensen, LLP  
181 Third Street, Suite 200  
San Rafael, CA 94901

All claims shall be delivered personally or sent by certified mail.

26. NON-DISCRIMINATION AND EQUAL EMPLOYMENT OPPORTUNITY. In the performance of this Contract, Contractor shall not discriminate against any employee, subcontractor or applicant for employment because of race, color, creed, religion, sex, marital status, sexual orientation, national origin, ancestry, age, physical or mental handicap, or medical condition. Contractor will take affirmative action to ensure that employees are treated without regard to race, color, creed, religion, sex, marital status, sexual orientation, national origin, ancestry, age, physical or mental handicap, or medical condition.

27. CONTRACT DOCUMENTS AND PRECEDENCE. The Contract Documents shall consist of the following documents. In case of inconsistencies between Contract Documents, the documents are listed in order of precedence.

28. PUBLIC WORKS CLAIMS. This Contract is subject to Public Contracts Code Section 9204 governing contractor claims.

29. ATTORNEYS' FEES; VENUE. In the event that any party to this Contract commences any legal action or proceeding to enforce or interpret the provisions of this Contract, the prevailing party in such action or proceeding shall be entitled to recover reasonable attorneys' fees and other costs incurred in that action or proceeding, in addition to any other relief to which the successful party may be entitled. The venue for any litigation shall be San Mateo County.

30. COOPERATION. In the event any claim or action is brought against the City relating to Contractor's performance or services under this Agreement, Contractor shall render any reasonable assistance and cooperation which City might require.

31. NUISANCE. Contractor shall not maintain, commit, nor permit the maintenance or commission of any nuisance in connection with the performance of services under this Contract.

32. GOVERNING LAW. This Contract shall be construed in accordance with and governed by the laws of the State of California.

33. COMPLETE AGREEMENT; SEVERABILITY. This Contract, and any other documents incorporated herein by reference, represent the entire and integrated agreement between the City and Contractor. This Contract supersedes all prior oral and written negotiations, representations or agreements. No prior



oral or written understanding shall be of any force or effect with respect to those matters covered hereunder. This Contract may only be modified by a written amendment duly executed by the parties to this Contract. In case a provision of this Contract is held to be invalid, illegal or unenforceable, the validity, legality and enforceability of the remaining provisions shall not be affected.

34. COUNTERPARTS. This Contract may be signed in multiple counterparts, which shall, when executed by all the parties constitute a single binding contract.

SIGNATURE PAGE TO FOLLOW

IN WITNESS WHEREOF, the parties hereto have executed this agreement on the day and year first above written.

**FOR FIRST PARTY:**

\_\_\_\_\_  
Signature

\_\_\_\_\_  
Date

\_\_\_\_\_  
Printed name

\_\_\_\_\_  
Title

\_\_\_\_\_  
Tax ID#

**APPROVED AS TO FORM:**

\_\_\_\_\_  
Nira F. Doherty, City Attorney

\_\_\_\_\_  
Date

**FOR CITY OF MENLO PARK:**

\_\_\_\_\_  
Starla Jerome-Robinson, City Manager

\_\_\_\_\_  
Date

**ATTEST:**

\_\_\_\_\_  
Judi A. Herren, City Clerk

\_\_\_\_\_  
Date



## STAFF REPORT

**City Council**  
**Meeting Date:** 8/17/2021  
**Staff Report Number:** 21-154-CC

**Consent Calendar:** **Adopt Resolution No. 6653 to authorize the city manager to accept the grant deed for 1155 Merrill St. Unit 209, execute all documents necessary to complete the purchase and approve the appropriation of below market rate housing funds not to exceed \$355,000 to purchase and retain the property in the below market rate housing program**

### Recommendation

Staff recommends that the City Council:

1. Adopt resolution No. 6653 (Attachment A) to authorize the city manager to accept the grant deed for 1155 Merrill St. Unit 209 and to execute all documents necessary to complete the purchase, including but not limited to a real estate purchase contract, escrow instructions and closing documents; and
2. Approve the appropriation of below market rate (BMR) housing funds not to exceed \$355,000 to purchase and retain 1155 Merrill St. Unit 209, a condominium unit, and thereafter sell the unit to an income-qualifying household.

### Policy Issues

The affordability restrictions on this unit were established in accordance with City requirements. The deed restrictions include a 90-day escrow closing provision that requires the City to purchase the unit in order to preserve the home in the BMR housing program, if the City does not identify a qualified buyer within the 90 days. Preserving the unit in the City's BMR housing program is consistent with the City's ongoing policies, programs and efforts to create and provide affordable homeownership opportunities for low and moderate-income households.

### Background

The aforementioned property, 1155 Merrill St. Unit 209, is located in a residential condominium building constructed in 2002 on Merrill Street between Santa Cruz Avenue and Oak Grove Avenue with a total of 25 residential condominium units. Three condominiums are BMR housing units that were sold to qualified, first-time homebuyers. Purchasers of BMR ownership units are required to meet the City's eligibility criteria as well as submit extensive financial records to ensure compliance with BMR requirements. Selected buyers are also required to sign deed restrictions and BMR subordination agreements that uphold the City's commitment to preserve existing affordable housing.

In compliance with the City of Menlo Park's BMR housing program guidelines (Attachment B), all BMR

units require deed restrictions and conditions that include a first right of refusal in favor of the City for a period of 55 years under which the City will be entitled to purchase the property or assign its right to an eligible buyer. Deed restrictions also prohibit sales or transfers of the property except with written consent of the City. When a current BMR homeowner decides to sell their unit, they are required to notify the City of their intent to sell. Subsequently, the City is obligated to find a qualified buyer within a given timeline outlined in the deed restriction. If time constraints do not allow for a qualified buyer to be identified, the City has the option to preserve the BMR unit by purchasing the property.

## Analysis

On June 16, 2021, the BMR homeowner of 1155 Merrill St. Unit 209 notified the City's BMR administrator of their intent to sell their home. The deed restriction for 1155 Merrill St. Unit 209, signed in 2002, stipulates the City has only 90 days, from the date of the receipt of intent to sell notice, to find a qualified buyer or complete the City's purchase of the property. The timeline of 90 days to identify a qualified buyer is not feasible, and staff is recommending City Council approve the appropriation of BMR housing funds to purchase the property and authorize the city manager to execute documents related to the purchase.

The benefit of proceeding with a City purchase at this time is that the City will be able to retain this valuable BMR unit in its stock of affordable housing and will then provide the requisite time necessary to identify a qualified buyer for the unit. It is impracticable to identify a qualified buyer and for the buyer to obtain the necessary mortgage financing to complete the purchase a BMR unit within 90 days from the time of receipt of the initial notice of intent to sell from the current owner. The 90-day timeline is antiquated and the City's current BMR deed restrictions include a provision of up to 180 days for the City to identify a qualified buyer, which is generally sufficient time. After the proposed purchase by the City of 1155 Merrill St. Unit 209, the City's BMR administrator will facilitate the identification of a qualified buyer and the resale of the BMR unit.

The current owner of 1155 Merrill St. Unit 209 qualified for the purchase of the property in 2002, which had a sales price of \$257,290. For all BMR ownership units, the initial sales prices is based on an income category up to 120 percent of the area median income as determined by the California Department of Housing and Community Development for San Mateo County. Included in the maximum sales price are monthly housing costs including mortgage payment, insurance costs, homeowners' dues, taxes, closing costs and any other consideration of costs of qualifying for a first mortgage and purchase of the BMR unit. These calculations are strictly followed to ensure the sales price and ownership expenses remain affordable according to the income category of first-time BMR homeowners.

In accordance with the City's BMR guidelines, the City or its designee establishes the resale price for the property, based on the original selling price of the unit, depreciated value of substantial improvements made by the seller and one-third of the increase in the cost of living index for the Bay Area. Applying this established formula, the estimated sales price for the property is \$308,000. This dollar amount is subject to change as the depreciated value of the current owner's improvements (e.g., installation of hardwood flooring, etc.) and any necessary work to make the unit in saleable condition are identified and evaluated. The full resale price is expected to be recovered at the time the City identifies a new buyer and moves forward with their resale of the property. Additional costs the City anticipates incurring, which are not expected to be recovered, include home inspection, escrow and closing cost, real estate agent fees and a

contingency for repairs after the purchase of the home before a new buyer being identified. These additional costs are expected to be equal to or less than \$47,000, some of which include contingency funds that may go unused. Combining the estimated sales price and added expenses, staff recommends appropriating a total of up to \$355,000 from the BMR housing fund toward the purchase of 1155 Merrill St. Unit 209. The majority of these funds will be returned to the City BMR fund when the BMR unit is sold to a qualified buyer within the next 3-6 months.

A summary of the BMR housing fund balance is provided in Table 1. At the close of the 2020-21 fiscal year, staff calculated approximately \$10.4 million in available BMR housing funds. City staff released the 2020 Notice of Funding Availability (NOFA) with available funding up to \$10 million during the 2020-21 fiscal year. Two of three NOFA proposals received have been approved by the City Council, listed in Table 1 as 6-8 Coleman Place and Habitat for Humanity ownership preservation. The remaining proposal from MidPen Housing requests \$3.6 million for the construction of 12 two-bedroom townhomes on Pierce Road proposed as BMR ownership units to households at 80% AMI. Staff is evaluating this proposal and will return to the City Council with more information and/or a recommendation for the proposal in the near future.

Table 1: BMR housing fund balance summary			
Notes payable	2019-20	2020-21	2021-22
Adjusted available balance <sup>1</sup>	\$21,741,831	\$17,212,791	\$10,397,291
1317-1385 Willow Road (approved)	(\$9,331,000)	-	-
1105 and 1141 Willow Road (approved)	(\$635,502)	-	-
6-8 Coleman Place (approved) <sup>2</sup>	-	(\$5,500,000)	-
Habitat for Humanity ownership preservation (approved) <sup>2</sup>	-	(\$1,200,000)	-
555 Hamilton Ave. (approved) <sup>3</sup>	-	(\$525,500)	-
2020 NOFA Pierce Road proposal (pending)	-	-	(\$3,600,000)
1155 Merrill St. Unit 209 (pending)	-	-	(\$355,000)
Assets (BMR in-lieu fees, interest, etc.)	\$5,437,462	\$410,000	-
Estimated ending balance	\$17,212,791	\$10,397,291	\$6,442,291

<sup>1</sup> Adjusted available balance reflects BMR fund balance less non-cash assets and commitments

<sup>2</sup> Approved proposals from the 2020 NOFA

<sup>3</sup> Expected sale of 555 Hamilton Ave. to a qualified BMR household expect to close by November 2021

With the median home price in Menlo Park surpassing \$2.5 million, retaining 1155 Merrill St. Unit 209 in the City’s BMR housing program is consistent with the policies, programs and efforts to preserve and provide affordable ownership opportunities for lower income households working or living in Menlo Park. There are a total of 68 deed restricted BMR ownership units in Menlo Park’s portfolio, including 1155 Merrill Unit 209. Additional ownership units are expected to be added with new developments currently in the pipeline, which will all include a provision of up to 180 days for the City to identify a qualified buyer. It is expected that new ownership units in the pipeline will take years to construct; therefore, retaining the existing portfolio is of utmost importance given the high cost of housing in Menlo Park. Furthermore, staff

is evaluating the BMR agreements of the City's entire ownership portfolio and may return to City Council with recommendations to address comprehensively the 90-day timeline included in the majority of BMR ownership agreements executed prior to 2016.

### **Impact on City Resources**

Up to \$355,000 from the City's BMR housing fund will be utilized for this action. The majority of these funds will be returned to the City BMR fund when the BMR unit is sold to a qualified buyer within the next 3-6 months.

### **Environmental Review**

This action is not a project within the meaning of the California Environmental Quality Act (CEQA) Guidelines §§ 15378 and 15061(b)(3) as it will not result in any direct or indirect physical change in the environment.

### **Public Notice**

Public notification was achieved by posting the agenda, with the agenda items being listed, at least 72 hours prior to the meeting.

### **Attachments**

- A. Resolution No. 6653
- B. Hyperlink – BMR housing program guidelines:  
[menlopark.org/DocumentCenter/View/1495/Below-Market-Rate-Housing-Program-Guidelines?bidId](https://menlopark.org/DocumentCenter/View/1495/Below-Market-Rate-Housing-Program-Guidelines?bidId)

Report prepared by:  
Michael Noce, Management Analyst II

Report reviewed by:  
Rhonda Coffman, Deputy Community Development Director – Housing

**RESOLUTION NO. 6653**

**RESOLUTION OF THE CITY COUNCIL OF THE CITY OF MENLO PARK  
AUTHORIZING THE CITY MANAGER TO ACCEPT THE GRANT DEED FOR  
1155 MERRILL STREET UNIT 209, EXECUTE ALL DOCUMENTS NECESSARY  
TO COMPLETE THE PURCHASE AND APPROVE THE APPROPRIATION OF  
UP TO \$355,000 FROM THE BELOW MARKET RATE (BMR) HOUSING FUND  
TO PURCHASE AND RETAIN THE PROPERTY IN THE BMR HOUSING  
PROGRAM**

WHEREAS, on August 17, 2021 the City Council for the City of Menlo Park allocates BMR housing funds not to exceed \$355,000 to purchase and retain 1155 Merrill St. Unit 209 [APN 114 090 170] (hereinafter the "Property");

WHEREAS, on August 6, 2002 the City entered into a below market rate (BMR) agreement and deed restriction regarding resale controls (hereinafter the "Agreement") with a qualified BMR homeowner (hereinafter the "Owner"), which provides that prior to a sale of the Property the Owner shall issue to the City a notice of intent to transfer the property and the City shall have 60 days to exercise a right of first refusal to accept Owner's offer to sell the Property;

WHEREAS, on the sixteenth day of June, 2021 the Owner provided City a notice of intent to transfer the Property;

WHEREAS, the need to facilitate affordable homeownership opportunities for low and moderate-income households remains a policy and priority in Menlo Park; and

WHEREAS, the BMR Program Guidelines allows the City of Menlo Park to purchase and preserve real estate property as an eligible use of the BMR Housing Fund; and

WHEREAS, the City of Menlo Park affirms the City's commitment to providing affordable homeownership units to lower income households;

WHEREAS, in order to ensure the Property remains within the City's BMR unit inventory, the City wishes to exercise its right of first refusal and acquire the Property from Owner.

NOW, THEREFORE, BE IT RESOLVED, that the City Council of Menlo Park hereby (a) authorizes the City Manager to exercise a right of first refusal on behalf of the City and accept the grant deed for 1155 Merrill St. Unit 209 and to execute all documents necessary to complete the purchase, including but not limited to a real estate purchase contract, escrow instructions and closing documents; and (b) approve the appropriation of below market rate (BMR) housing funds not to exceed \$355,000 to purchase and retain 1155 Merrill St. Unit 209, a condominium unit, and thereafter sell the unit to an income-qualifying household in accordance with Menlo Park Municipal Code Ch. 16.96 and the City's BMR Program Guidelines.

//  
  
//  
  
//  
  
//

I, Judi A. Herren, City Clerk of Menlo Park, do hereby certify that the above and foregoing City Council Resolution was duly and regularly passed and adopted at a meeting by said City Council on the seventeenth day of August, 2021, by the following votes:

AYES:

NOES:

ABSENT:

ABSTAIN:

IN WITNESS WHEREOF, I have hereunto set my hand and affixed the Official Seal of said City on this seventeenth day of August, 2021.

---

Judi A. Herren, City Clerk





**STAFF REPORT**

**City Council**

**Meeting Date:**

**8/17/2021**

**Staff Report Number:**

**21-155-CC**

**Consent Calendar:**

**Establish the Reimagining Public Safety Ad Hoc Subcommittee and appoint City Councilmembers Taylor and Wolosin**

**Recommendation**

Staff recommends that the City Council establish the Reimagining Public Safety Ad Hoc Subcommittee (Subcommittee) and appoint City Councilmembers Taylor and Wolosin.

**Policy Issues**

According to City Council policy #CC-19-010, City Council Powers and Responsibilities, (Attachment A), City Council subcommittees are to help the City Council do its job. Subcommittees ordinarily will assist the City Council by preparing policy alternatives and implications for City Council deliberation. City Council subcommittees may not speak or act for the City Council. Subcommittees will be used sparingly and ordinarily in an ad hoc capacity. This policy applies to any group that is formed by City Council action, whether or not it is called a subcommittee. Unless otherwise stated, a subcommittee is deemed to be ad hoc and ceases to exist as soon as its task is complete. Standing subcommittees are City Council subcommittees with regular responsibilities as assigned by the City Council generally spanning more than a single year or project. Standing subcommittees are subject to the Open Meetings Act (e.g., Brown Act.)

**Background**

At the July 29 study session, the City Council directed staff to return with an action item to establish the Reimagining Public Safety Ad Hoc Subcommittee and appoint City Councilmembers Taylor and Wolosin.

**Analysis**

The Subcommittee will be charged with working with Police Chief Norris to prioritize topics, create a process, and provide a timeline for the full City Council to consider. The duration of this is Subcommittee is through December 31, 2021.

**Impact on City Resources**

Impacts on City resources is related to staff time to schedule and attended Subcommittee meetings as needed.

**Environmental Review**

This action is not a project within the meaning of the California Environmental Quality Act (CEQA) Guidelines §§ 15378 and 15061(b)(3) as it will not result in any direct or indirect physical change in the environment.

**Public Notice**

Public notification was achieved by posting the agenda, with the agenda items being listed, at least 72 hours prior to the meeting.

**Attachments**

A. City Council policy #CC-19-010, City Council Powers and Responsibilities

Report prepared by:

Judi A. Herren, City Clerk

Report reviewed by:

Nick Pegueros, Assistant City Manager

# City Council Powers and Responsibilities

City Council Procedure #CC-19-010

Adopted November 12, 2019

ATTACHMENT A



## Purpose

The powers of the City Council to establish policy are quite broad. Essentially, the City Council may undertake any action related to city affairs other than those forbidden or preempted by state or federal law. Specifically, the City Council has the power, in the name of the city, to do and perform all acts and things appropriate to a municipal corporation and for the general welfare of its inhabitants which are not specifically forbidden by the Constitution and laws of the State of California.

It is important to note that the City Council acts as a body. No member has any extraordinary powers beyond those of other members. While the Mayor and Vice Mayor have some additional ceremonial and administrative responsibilities as described below, in the establishment execution of policies and procedures, all city councilmembers are equal.

It is also important to note that policy is established by at least a majority vote of the City Council. While individual city councilmembers may disagree with decisions of the majority, a decision of the majority does bind the City Council to a course of action. In turn, it is staff's responsibility to ensure the policy of the City Council is upheld. Actions of staff to pursue the policy direction established by a majority of the City Council do not reflect any bias against city councilmembers who held a minority opinion on an issue.

## Appointment of City Council officers and City Council subcommittees

### Selection of Mayor and Vice Mayor

The City Council shall meet in December of each year to choose one of its members as Mayor and one as Mayor Pro Tempore.<sup>1</sup> The City Council has determined that for the purpose of this policy, the "Mayor Pro Tempore" title shall be replaced with "Vice Mayor" beginning with the annual rotation in December 2019.

### *Mayor*

The Mayor presides at all meetings of the City Council and performs such other duties consistent with the office as may be imposed by the City Council or by vote of the people. The Mayor does not possess any power of veto. As presiding officer of the City Council, the Mayor is to faithfully communicate the will of the City Council majority in matters of policy. The Mayor is also recognized as the official head of the city for all ceremonial purposes.

The Mayor, unless unavailable, shall sign all ordinances, and other documents that have been adopted by the City Council and require an official signature; except when the city manager has been authorized by City Council action to sign documents. In the event the Mayor is unavailable, the Vice Mayor's signature may be used.

The Mayor also consults and coordinates with the city manager and Vice Mayor in the development of agendas for meetings of the City Council. The Mayor shall appoint members of the Planning Commission, with the approval of the City Council<sup>2</sup>, and the Mayor has additional roles and responsibilities in the event of a declared disaster including serving as chairperson of the Disaster Council<sup>3</sup>.

### *Vice Mayor*

The Vice Mayor shall perform the duties of the Mayor during the Mayor's absence, at the pleasure of the City Council.

### Appointment of City Council subcommittees

City Council subcommittees, when used, are to help the City Council do its job. Subcommittees ordinarily will assist the City Council by preparing policy alternatives and implications for City Council deliberation. City Council subcommittees may not speak or act for the City Council. Subcommittees will be used sparingly and ordinarily in an ad hoc capacity. This policy applies to any group that is formed by City Council action, whether or not it is called a subcommittee. Unless otherwise stated, a subcommittee is deemed to be ad hoc and ceases to exist as soon as its task is complete. Standing subcommittees are City Council subcommittees with regular responsibilities as assigned by the City Council generally spanning more than a single year or project. Standing subcommittees are subject to the Open Meetings Act (Brown Act.) Ad hoc subcommittees are not listed below considering their limited nature.

<sup>1</sup> MPMC Section [2.04.120](#)

<sup>2</sup> MPMC Section [2.12.020](#)

<sup>3</sup> MPMC Section [2.44.040](#)

**City Council Powers and Responsibilities**

City Council Procedure #CC-19-010

Adopted November 12, 2019

<b>Standing City Council subcommittees</b>
Community grant funding
Rail

**Appointment of City Councilmembers to outside boards and organizations**

Typically, appointments to outside boards and organizations are made at the beginning of a City Council term in December. The Mayor will ask city councilmembers which appointments they desire and will submit recommendations to the full City Council regarding the various outside appointments. Certain appointments are reserved for the incumbent Mayor and Vice Mayor as primary and alternate members, respectively. Alternates shall also be appointed to ensure participation in the decision making processes of outside boards and organizations. In the instance where more than one city councilmember wishes to be appointed to an outside board or organization, a vote of the City Council will be taken to confirm appointment of the primary and alternate appointees. Outside boards and organization appointments are as follows:

<b>Outside boards</b>	<b>Notes</b>
Association of Bay Area Government (ABAG)	Incumbent Mayor and Vice Mayor
Bay Area Water Conservation Agency (BAWSCA)	4-year appointment
City/County Association of Governments (C/CAG)	
Emergency Services Council	
Peninsula Clean Energy Authority (PCE)	
San Francisquito Creek Joint Powers Authority	
South Bayside Waste Management Authority	

<b>Outside organizations</b>	<b>Notes</b>
Airport Community Roundtable	
Caltrain Modernization Local Policy Maker Group	Same members as the Rail Subcommittee
County of Santa Clara Community Resources Group for Stanford University	Same members as subcommittees pertaining to Stanford University
Facebook Local Community Fund	
Grand Boulevard Initiative Taskforce	
League of California Cities (League/LCC), including LCC Peninsula Division	Incumbent Mayor and Vice Mayor
Menlo Park Chamber of Commerce	Incumbent Mayor and Vice Mayor
San Mateo County Council of Cities City Selection Committee	Incumbent Mayor and Vice Mayor

As a City Council appointee to an outside board or organization, the appointee shall represent the policy set by the majority of the City Council at a public meeting. If the appointee is unclear as to the position of the City Council on a particular business item scheduled for vote at the outside board or organization, the appointee shall consult the full City Council under “City Councilmember Reports” section of the public meeting agenda or, if sufficient time is not available, consult the city manager.

Appointees to an outside board or organization shall report to the City Council under “City Councilmember Reports” following each meeting.

As a member of an outside board or organization, appointees must attend all regular scheduled meetings of the outside board or organization to ensure that Menlo Park has a voice on matters of significance to the community. If an appointee is not available, s/he shall coordinate with the alternate to ensure Menlo Park representation.

**Appointment of advisory bodies and advisory body liaisons**

Advisory bodies  
 The City Council has formed several commissions, committees, and taskforces, collectively referred to as “advisory bodies”. The City Council shall adopt a City Council procedure to provide guidelines on the appointment, roles, and responsibilities<sup>4</sup> of the various advisory bodies excluding the Planning Commission which is established by Municipal Code<sup>5</sup> and is vested with statutory duties.

<sup>4</sup> MPMC Section [2.04.200](#)

<sup>5</sup> MPMC Section [2.12.040](#)

**City Council Powers and Responsibilities**

City Council Procedure #CC-19-010

Adopted November 12, 2019

<b>2019 Commissions</b>	<b>2019 Committees/Taskforces<sup>6</sup></b>
Complete Streets Commission	Belle Haven Neighborhood Library Advisory Committee
Environmental Quality Commission	Finance and Audit Committee
Housing Commission	Sister City Committee
Library Commission	Transportation Master Plan Oversight and Outreach Committee
Parks & Recreation Commission	
Planning Commission	

Liaisons to City Council advisory bodies

City councilmembers are assigned to serve in a liaison capacity with one or more City Council advisory bodies. The purpose of the liaison assignments is to facilitate communication between the City Council and the advisory body. The liaison also helps to increase the City Council's familiarity with the membership, programs, and issues of the advisory body. In fulfilling their liaison assignment, city councilmembers may elect to attend advisory body meetings periodically to observe the activities of the advisory body or simply maintain communication with the advisory body Chair on a regular basis.

*Assignment of liaisons*

Typically, advisory body liaison assignments are made at the beginning of a City Council term in December. The Mayor will ask city councilmembers which liaison assignments they desire and will submit recommendations to the full City Council regarding the assignments. In the instance where more than one city councilmembers wish to be the appointed liaison to a City Council advisory body, a vote of the City Council will be taken to confirm assignments.

City Councilmembers should be sensitive to the fact that they are not participating members of the advisory body but are there rather to create a linkage between the City Council and advisory body. In interacting with advisory bodies, city councilmembers are to reflect the views of the City Council as a body. Being an advisory body liaison bestows no special right with respect to advisory body business.

City Council relationship with advisory bodies

The City Council has determined that city councilmembers should not lobby advisory body members for particular votes. However, city councilmembers may attend meetings as residents and request that advisory body members consider certain issues during their deliberations or in unusual instances as city councilmembers to reflect the views of the City Council as a body.

City Councilmembers choosing to attend advisory body meetings should be sensitive to the fact that they are not participating members of the body. City Councilmembers have the rights, and only the rights, of ordinary citizens with respect to advisory bodies – including the right to write to and speak to the advisory body during public comment periods.

**Appointment of city attorney and city manager**

The City Council appoints two positions within the city organization: the city manager and city attorney. Both positions serve at the will of the City Council and have employment agreements that specify certain terms of employment including an annual evaluation by the City Council.

Appointment of city attorney

The city attorney is the legal adviser for the City Council, city manager and departments. The general legal responsibilities of the city attorney are to: 1) provide legal assistance necessary for formulation and implementation of legislative policies and projects; 2) represent the city's interest, as determined by the City Council, in litigation, administrative hearings, negotiations and similar proceedings; 3) prepare ordinances, resolutions, contracts and other legal documents to best reflect and implement the purposes for which they are prepared; and 4) keep the City Council and staff apprised of court rulings and legislation affecting the legal interest of the City. It is important to note that the city attorney does not represent individual city councilmembers, but the City Council as a whole.

Appointment of city manager

The city manager shall be appointed by the City Council solely on the basis of his or her executive and administrative qualifications and ability. He or she shall hold office at and during the pleasure of the City Council<sup>7</sup>. The city manager shall receive such compensation as the City Council from time to time determines and fixes by resolution and such compensation shall be a proper charge against such funds of the city that the City Council designates<sup>8</sup>.

<sup>6</sup> 2019 Committees and taskforces all have City Councilmembers serving as voting members and no liaison is required.

<sup>7</sup> MPMC Section [2.08.010](#)

<sup>8</sup> MPMC Section [2.08.060](#)

## City Council Powers and Responsibilities

City Council Procedure #CC-19-010

Adopted November 12, 2019

4

The city manager shall be the administrative head of the city government under the direction and control of the city council, except as otherwise provided in the Municipal Code. He or she shall be responsible for the efficient administration of all the affairs of the city, which are under his or her control. In addition to his or her general powers as administrative head, and not as a limitation thereon, it shall be his or her duty and he or she shall have the power<sup>9</sup>:

1. Enforcement of laws. To see that all laws and ordinances of the city are duly enforced, and that all franchises, permits and privileges granted by the city are faithfully observed;
2. To direct, etc., officers and employees. To control, order and give directions to all heads of departments, subordinate officers, and employees of the city, except the city attorney; and to transfer employees from one (1) department to another, and to consolidate or combine offices, positions, departments or units under his or her direction;
3. Appointment and removal of officers and employees. To appoint and remove any officers and employees of the city except the city attorney, subject to the rules relating to personnel management;
4. Control of departments and officers and employees. To exercise control over all departments of the city government and over all appointive officers and employees thereof, except the city attorney;
5. Attendance at City Council meetings. To attend all meetings of the city council unless excused therefrom by the city council, except when his or her removal is under consideration by the city council;
6. Recommendation of ordinances. To recommend to the city council for adoption such measures and ordinances as he or she deems necessary or expedient;
7. Fiscal advice. To keep the City Council at all times fully advised as to the financial conditions and needs of the city;
8. Preparation of budget. To prepare and submit to the City Council the annual budget;
9. Purchases and expenditures. To purchase all supplies for all of the departments or divisions of the city. No expenditure shall be submitted or recommended to the City Council, except on report or approval of the city manager;
10. Investigation of city affairs. To make investigations into the affairs of the city, and any department or division thereof, and any contract, or the proper performance of any obligations running to the city;
11. Investigation of complaints. To investigate all complaints in relation to matters concerning the administration of the city government and in regard to the service maintained by public utilities in the city, and to see that all franchises, permits and privileges granted by the city are faithfully performed and observed;
12. Supervision of public buildings. To exercise general supervision over all public buildings, public parks and other public property which are under the control and jurisdiction of the City Council and not specifically delegated to a particular board or officer;
13. Approval of plans and designs. To exercise directly or through his or her designee discretionary approval of plans, designs and any design amendments or addenda for public improvement projects for which the city council has delegated authority to the city manager or which are within the city manager's discretionary authority. The city manager or his or her designee shall sign the plans and designs indicating approval;
14. Devotion of entire time to duties. To devote his or her entire time to the duties of his or her office and the interests of the city;
15. Leadership in civic movements. To provide leadership for civic movements designed to benefit the residents of the city when so authorized by the City Council;
16. Additional duties. To perform such other duties and exercise such other powers as may be delegated to him or her from time to time by ordinance or resolution of the City Council.

<sup>9</sup> MPMC Section [2.08.080](#)

## City Council Powers and Responsibilities

City Council Procedure #CC-19-010

Adopted November 12, 2019

5

The City Council and its members shall deal with the administrative services of the city only through the city manager, except for the purpose of inquiry, and neither the City Council nor any members thereof shall give orders to any subordinates of the city manager<sup>10</sup>.

### City manager code of ethics

The city manager is subject to the International City/County Management Association (ICMA) professional code of ethics that binds the city manager to certain practices that are designed to ensure his or her actions are in support of the city's best interests. Violations of such standards can result in censure.

The mission of ICMA is to create excellence in local governance by developing and fostering professional local government management worldwide. To further this mission, certain principles, as enforced by ICMA Rules of Procedure, shall govern the conduct of every member of ICMA, who shall:

1. Be dedicated to the concepts of effective and democratic local government by responsible elected officials and believe that professional general management is essential to the achievement of this objective.
2. Affirm the dignity and worth of the services rendered by government and maintain a constructive, creative, and practical attitude toward local government affairs and a deep sense of social responsibility as a trusted public servant.
3. Be dedicated to the highest ideals of honor and integrity in all public and personal relationships in order that the member may merit the respect and confidence of the elected officials, of other officials and employees, and of the public.
4. Serve the best interests of the people.
5. Submit policy proposals to elected officials; provide them with facts and advice on matters of policy as a basis for making decisions and setting community goals; and uphold and implement local government policies adopted by elected officials.
6. Recognize that elected representatives of the people are entitled to the credit for the establishment of local government policies; responsibility for policy execution rests with the members.
7. Refrain from all political activities which undermine public confidence in professional administrators. Refrain from participation in the election of the members of the employing legislative body.
8. Make it a duty continually to improve the member's professional ability and to develop the competence of associates in the use of management techniques.
9. Keep the community informed on local government affairs; encourage communication between the citizens and all local government officers; emphasize friendly and courteous service to the public; and seek to improve the quality and image of public service.
10. Resist any encroachment on professional responsibilities, believing the member should be free to carry out official policies without interference, and handle each problem without discrimination on the basis of principle and justice.
11. Handle all matters of personnel on the basis of merit so that fairness and impartiality govern a member's decisions pertaining to appointments, pay adjustments, promotions, and discipline.
12. Public office is a public trust. A member shall not leverage his or her position for personal gain or benefit.

<sup>10</sup> MPMC Section [2.08.100](#)

**City Council Powers and Responsibilities**

City Council Procedure #CC-19-010

Adopted November 12, 2019

**Appointment to vacancies on the City Council**

If a vacancy occurs in the office of a member of the City Council, an election shall be held to fill the vacancy. The person elected shall hold office for the unexpired term of the former incumbent. The election shall be held at the next regularly scheduled election held at least eighty-nine days after the vacancy is created.<sup>11</sup>

The city councilmember elected to represent a district must reside in that district and be a registered voter in that district. Termination of residency in a district by a city councilmember shall create an immediate vacancy for that City Council district unless a substitute residence within the district is established within thirty (30) days after the termination of residency.<sup>12</sup>

**Procedure history**

Action	Date	Notes
Draft procedure presented	October 1, 2019	City Council directed edits
Procedure adoption	November 19, 2019	

<sup>11</sup> MPMC Section [2.04.190](#)

<sup>12</sup> MPMC Section [2.04.220](#)





**STAFF REPORT**

**City Council**  
**Meeting Date:** 8/17/2021  
**Staff Report Number:** 21-144-CC

**Regular Business:** **Adopt Resolution No. 6648 to ratify successor agreement between the City of Menlo Park and the Service Employees International Union Local 521 expiring June 30, 2023**

**Recommendation**

Adopt Resolution No. 6648 to ratify a successor agreement between the City of Menlo Park and the Service Employees International Union Local 521 (SEIU) expiring June 30, 2023.

UPDATE – This report has been updated from the early release version with several edits indicated in red underlined text.

**Policy Issues**

City Council retains sole authority to enter into memoranda of understanding with recognized labor units. Memorandum of understanding (MOU) negotiations are governed by the Meyers-Milias-Brown Act (MMBA), Government Code section 3500. MMBA requires that local agencies meet and confer in good faith regarding wages, hours, and other terms and conditions of employment with representatives of recognized collective bargaining units. MMBA further requires that the City fully consider proposals made by collective bargaining unit representatives before determining policy or course of action.

**Background**

City Council held its initial hearing to receive public input before launching negotiations with SEIU February 9. After the public input hearing, City Council appointed Charles Sakai of Sloan Sakai Yeung & Wong LLP to serve as the City's chief negotiator. Mr. Sakai received direction to negotiate the successor MOU with SEIU, and both parties reached a tentative agreement (Attachment A) June 2.

The previous MOU for SEIU represented employees had original terms of October 1, 2017, through June 30, 2020. The MOU was then extended to expire June 30, 2021, and added the California State Disability Insurance (SDI) benefit and modified the long-term disability program to coordinate with SDI. SEIU agreed to defer their July 2020 inflation-based across-the-board wage increase at the City's request due to the financial uncertainty resulting from the COVID-19 pandemic. Under that agreement, classifications and employees represented by SEIU received the deferred July 2020 inflation-based wage increase of 2.9 percent effective June 20, 2021. The MOU between City and SEIU expired June 30, 2021 so the wage increase that was deferred to June 20, 2021 was within the extended MOU term. Additionally, City past practice honors the terms and intent of expired MOUs until the full ratification of a successor agreement.

**Analysis**

This report summarizes the tentative agreement negotiated in good faith with SEIU representatives. SEIU’s membership ratified the tentative agreement June 15. While the tentative agreement conforms to the authority provided to Mr. Sakai in closed session, the final action requires City Council ratification at a public meeting. The City Council adopted 2021-22 budget fully funds the tentative agreement provisions.

Attachment A transmits a redline version of the expired MOU to highlight the tentative agreement for City Council ratification. Table 1 summarizes tentative agreement terms with financial impacts.

Table 1: Tentative agreement items with financial impact to City		
Item	Description	Cost/ (savings)
<b>Term</b> MOU Article 25 Page 57	The tentative agreement (TA) provides for a two-year term beginning with City Council ratification and ending June 30, 2023. Given that negotiation of a successor agreement is not required for one fiscal year, the City is estimated to save approximately \$30,000 per year which reflects legal costs and internal staff time required to support negotiations.	(\$30,000)
<b>Pay rates</b> MOU Section 7.1 Page 19	Assuming City Council ratification August 17, 2021, the TA includes an across the board cost of living adjustment to all pay rates in this unit, as follows: <ul style="list-style-type: none"> <li>• 3% effective the pay period following July 1, 2022</li> </ul>	\$396,997
<b>Lump sum payments</b> MOU Section 7.1.1 Page 20	The TA provides a lump sum payment to all employees in this unit as follows: <ul style="list-style-type: none"> <li>• \$2,000 per employee effective the pay period following ratification in 2021</li> <li>• \$2,000 per employee effective the pay period following July 1, 2022</li> </ul>	294,025 <u>294,025</u> \$588,050
<b>Flexible benefits plan contribution</b> MOU Section 13.1.2 Page 41	The TA includes an across the board increase in flexible benefits plan contribution based on the annual Consumer Price Index for the San Francisco Bay Area: <ul style="list-style-type: none"> <li>• 2022 CPI* Increase between 2-4%</li> <li>• 2023 CPI Increase between 2-4%</li> </ul>	72,920 <u>75,107</u> \$148,027
<b>Total</b>	Year 1 Year 2, incremental Contract term, compounded	\$366,945 \$736,129 \$809,049

\* Consumer price index

Classification and compensation study (MOU Section 7.1.2, Page 20)

The City last completed a classification and compensation study for non-sworn personnel in 2015-16. The 2015-16 study's results informed salary increases for those positions and job families found to be below market median total compensation. Total compensation incorporates the full range of wages and benefits, including pension costs and pension cost-share. The tentative agreement requires the City to retain a survey consultant, similar to the 2015-16 total compensation study. Unlike the 2015-16 study, Section 7.1.3 does not result in salary increases for positions identified as below market. The provision intends to inform negotiations of a successor agreement effective July 1, 2023, alongside the City's financial recovery, including assessed values for the 2021 and 2022 property tax rolls and the status of transient occupancy tax (TOT) revenue.

City staff will request proposals from qualified consultants in the first half of 2022 to meet the deadline of October 31, 2022, for the survey results. The cost is unknown.

**Impact on City Resources**

The City Council adopted budget incorporates the terms of the tentative agreement. The net increase in City costs is \$809,049 over the life of the contract.

**Environmental Review**

This action is not a project within the meaning of the California Environmental Quality Act (CEQA) Guidelines §§ 15378 and 15061(b)(3) as it will not result in any direct or indirect physical change in the environment.

**Public Notice**

Public notification was achieved by posting the report 15 days prior to the City Council meeting of August 17, 2021.

**Attachments**

- A. Redline version – MOU between SEIU and City of Menlo Park, July 1, 2021 – June 30, 2023
- B. Resolution No. 6648

Report prepared by:

Barbara Tong, Management Analyst I

Kristen Middleton, Interim Human Resources Manager

Nick Pegueros, Assistant City Manager

**MEMORANDUM OF UNDERSTANDING**  
**BETWEEN**  
**LOCAL 521**  
**SERVICE EMPLOYEES INTERNATIONAL UNION,**  
**CTW, CLC**  
**AND**  
**THE CITY OF MENLO PARK**



**October 1, 2017 through June 30, 2020****July 1, 2021**  
**– June 30, 2023**



## TABLE OF CONTENTS

	Page
PREAMBLE.....	4
ARTICLE 1: RECOGNITION.....	4
ARTICLE 2: UNION SECURITY.....	5
ARTICLE 3: REPRESENTATION.....	8
ARTICLE 4: DEFINITIONS.....	9
ARTICLE 5: LAYOFF AND RE-EMPLOYMENT.....	9
ARTICLE 6: PERSONNEL ACTION.....	13
6.1: Probation.....	13
6.2: Performance Evaluation.....	14
6.3: Performance Improvement Plan.....	15
6.4: Personnel Files.....	15
6.5: Promotional Opportunities.....	16
6.6: Reclassification.....	16
6.7: Flexible Staffing.....	17
ARTICLE 7: PAY RATES AND PRACTICES.....	18
7.1: Overall Wage Adjustments.....	18
7.2: Step Increases.....	18
7.3: Application of Rates.....	19
7.4: Effect of Promotion, Demotion or Transfer on Salaries.....	19
7.5: Bilingual Differential.....	20
7.6: Call Back Pay.....	20
7.7: Standby Pay.....	21
7.8: Rest Period Following Emergency Work.....	21
7.9: Working Out of Classification.....	21
7.10: Night and Weekend Differential.....	22
7.11: Court Appearances.....	22
ARTICLE 8: HOURS AND OVERTIME.....	23
ARTICLE 9: UNIFORMS.....	25
ARTICLE 10: HOLIDAYS.....	26
ARTICLE 11: VACATIONS.....	30
ARTICLE 12: LEAVE PROVISIONS.....	31
12.1: Sick Leave.....	31
12.2: Long Term Disability.....	34
12.3: Personal Business.....	35
12.4: Leave Without Pay.....	35
12.5: Jury Duty and Subpoenas.....	36
12.6: Military Leave.....	36
12.7: Bereavement Leave.....	36
12.8: Maternity and Parental Leave.....	37
12.9: Miscellaneous Leave Provisions.....	37
12.10: Educational Leave and Tuition Reimbursement.....	38
ARTICLE 13: BENEFIT PROGRAMS.....	39
ARTICLE 14: RETIREMENT.....	42
ARTICLE 15: GRIEVANCE PROCEDURE.....	43
ARTICLE 16: EFFECT ON EXISTING PRACTICES.....	48
ARTICLE 17: NONDISCRIMINATION.....	49

ARTICLE 18: MANAGEMENT RIGHTS.....	49
ARTICLE 19: CONCERTED ACTIVITIES.....	51
ARTICLE 20: SEPARABILITY.....	52
ARTICLE 21: DISCIPLINARY ACTION.....	52
ARTICLE 22: TRANSFER.....	53
ARTICLE 23: SAFETY.....	54
ARTICLE 24: CONTRACTING SERVICES .....	55
ARTICLE 25: TERM OF AGREEMENT.....	55
APPENDIX A: CLASSIFICATIONS	
APPENDIX B: PAY RANGES	
APPENDIX C: LABOR/MANAGEMENT COMMITTEE	
APPENDIX D: FMLA/CFRA NOTICE	
APPENDIX E: VACATION CASHOUT POLICY AND PROCEDURES	

## PREAMBLE

This Memorandum of Understanding is entered into by and between Service Employees' International Union, Local 521, CTW, CLC (hereinafter "Union") and the City of Menlo Park (hereinafter "City"). This Memorandum of Understanding is entered into pursuant to the Meyers-Milias-Brown Act (Government Code Sections 3500-3510) and has been jointly prepared by the parties.

### ARTICLE 1: RECOGNITION

- 1.1 The Union is recognized as the exclusive representative for the classifications of City workers as listed in Appendix "A" to this Agreement. Nothing herein shall be construed to discriminate against any individual who chooses to exercise his/her right of self-representation under Section 3502 of the Government Code.
- 1.2 Each newly established job classification shall be assigned to an appropriate representation unit by the Human Resources Director, after consultation with recognized employee organizations, if they find that there is an appropriate unit to which such job classifications may be assigned. An employee organization may appeal in writing from such assignment to the Human Resources Director within thirty (30) calendar days of said determination. If the Union is unsatisfied with the results of said appeal, the Union may invoke impasse procedures in accordance with Government Code 3500.

In general the City shall adhere to objectives which require that the appropriate unit shall be the broadest feasible grouping of positions that share an identifiable community of interests. Factors to be considered may include:

- a. Similarity of the general kinds of work performed, types of qualifications required and the general working conditions.
- b. History of representation in the City and similar environment.
- c. Consistency with the organizational patterns of the City of Menlo Park.
- d. Number of employees and classifications, and the effect on the administration of employer-employee relations created by the fragmentation of classifications and proliferation of units.
- e. Effect on the classification structure and impact on the stability of employer-employee relationship of dividing single or related classifications among two or more units.



## ARTICLE 2: UNION SECURITY

### 2.1 Agency Shop

2.1.1 Duty of Fair Representation. The Union has the duty to provide fair and non-discriminatory representation to all workers covered by this Memorandum of Understanding, regardless of whether they are members of the Union.

2.1.2 Implementation. Effective March 11, 2001, all unit members, as a condition of initial and continued employment, for the duration of this Agreement, shall either (a) become a member of the Union, or (b) pay a service fee to the Union in lieu of membership, or (c) claim religious exemption as a member of a bona fide religion, body or sect that has historically held conscientious objections to joining or financially supporting public employee organizations, as provided in Section 3502.5(c) of the Government Code.

When a person is hired in any of the covered job classifications, the City shall notify that person that the Union is the recognized bargaining representative for the worker's representation unit, that the Union and the City have entered into an Agency shop agreement requiring payment listed above as a condition of employment, provide an enrollment card (furnished by the Union) and give the worker a current copy of the Memorandum of Understanding.

Workers shall be free to become a member of the Union or to refrain from becoming a member of the Union. Workers who voluntarily become Union members shall maintain their membership in the Union for the duration of this Memorandum of Understanding, provided, however, that workers may resign Union membership during the first five business days of September of the final year of the Memorandum of Understanding, by notifying the Union and the Personnel Division in writing by registered mail, postmarked within the withdrawal period.

If an individual employee becomes delinquent in paying fees required under this Section due to a clerical error or the fact that the employee was not paid by the City during the pay period, the City shall not be responsible for paying such fees. However, once the City has been notified of the error, the City will make the correction within that pay period. In cases where a worker is not paid for a portion of the pay period and their salary is insufficient to cover part or all of the withholding of union dues or service fees, or their statutory withholding obligations exceed the withholding of union dues or service fees, there shall be no withholding. All legal, statutory and required deductions shall have priority over fees.

Each regular pay period, the City shall provide the Union with a list of the names, addresses, classifications, and membership status of all unit workers except those who file written notice with the Personnel Division objecting to the release of addresses, in which case information will be transmitted without address. Once a month, the City shall supply the Union with a list of representation unit new hires, terminations and retirements that occurred during the previous month.

The Union shall indemnify and hold the City, its officers and employees, harmless from any and all claims of any nature whatsoever, and against any claim or suit instituted against or involving the City arising from the execution of the City's obligations contained in this Article or from the use of the monies remitted to the Union, including the costs of defending against such actions or claims.

- 2.1.3 Dues Deduction. The City will deduct Union membership dues, agency fees, insurance fees, and any other mutually agreed upon payroll deduction from the biweekly pay of the worker, effective with the first pay period the worker is employed, subject to the provisions contained in Section 2.1.2. The worker must authorize deduction of membership dues in writing on an enrollment card acceptable to the City and the Union. In cases where an enrollment card has not been returned, the mandatory service fee shall be deducted from the biweekly pay of the worker. The City shall remit the deducted dues and other fees to the Union as soon as possible after deduction. The membership status report and dues deduction report shall be electronically transmitted to the Union via e-mail or other mutually agreeable method.

In cases where, for whatever reason, (e.g., the City being enjoined from collecting dues or service fees), a worker is delinquent in the payment of such dues or service fees, the Union shall utilize the judicial process to compel payment.

- 2.1.4 Establishment of Service Fee. The Union shall demonstrate to the City that it has complied with applicable law by (a) having disseminated to the bargaining unit adequate information about its expenditures for the preceding fiscal year, including information regarding its "chargeable" and "nonchargeable" activities in the prior fiscal year, broken down in adequate and reasonable detail between the chargeable and nonchargeable activities; (b) having established a full, fair and prompt procedure whereby objecting nonmembers are able to challenge allegedly objectionable expenditures; and (c) having established a procedure for escrowing the amount reasonably in dispute in connection with any challenge by an objecting non-member. The Union shall demonstrate its compliance with this Section before implementation of agency shop provisions, and on an annual basis thereafter.

2.1.5 Religious Exemption. Any worker occupying a position covered by this Memorandum of Understanding, who is a member of a bona fide religion, body or sect that has historically held conscientious objections to joining or financially supporting a public employee organization will, upon presentation of a written declaration to the Union and the City of active membership, notarized by an official representative of such religion, body or sect, be permitted to make a charitable contribution to one of the charities available through payroll deduction, equal to the service fee in lieu of Union membership or service fee payment.

The Union will have thirty days after receipt of a declaration of religious exemption to challenge any exemption that the City grants. If challenged, the deduction to the charity of the employee's choice will commence but will be held in escrow pending resolution of the challenge. Charitable contributions will be by regular payroll deduction only. For purposes of this Section, charitable deduction means a contribution to a non-religious, non-labor charitable organization available through the City's United Way or Combined Health Agencies payroll deduction slot, exempt from taxation under Section 501 of the IRS Code.

2.1.6 Financial Reports. The Union shall comply with Government Code §3502.5(d), which addresses the financial reporting requirements to agencies with negotiated agency shop provisions.

2.2 Except in cases of emergency, the Union shall be informed sufficiently in advance in writing by Management before any proposed changes not covered by this Memorandum of Understanding are made in benefits, working conditions, or other terms and conditions of employment which require the meet and confer or meet and consult process.

2.3 C.O.P.E. Checkoff. All workers who choose to do so may request an additional deduction from their paychecks to be forwarded to the Union and accounted for in a separate notation. Such additional deduction shall be used for political campaign purposes and shall be totally voluntary. The C.O.P.E. checkoff report shall be electronically transmitted to the Union via e-mail or other mutually agreeable method.

2.4 Bulletin Boards. The City shall furnish and maintain bulletin board space for use by the Union of a size and location mutually agreeable to the City and the Union. The bulletin board space provided shall be clearly identified as Union bulletin board space. The board may be used for the following subjects:

- (a) Information on Union elections, reports, newsletters and notices;
- (b) Reports of official business of the Union, including reports of committees or the governing boards thereof;

- (c) Scheduled membership benefits, programs and promotions;
- (d) Any other written material pertaining to the official business of the Union, the Santa Clara County or San Mateo County Central Labor Council or the Committee on Political Education (COPE).

### ARTICLE 3: REPRESENTATION

- 3.1 It is agreed that, as long as there is no disruption of work, five (5) Union representatives shall be allowed reasonable release time away from their work duties, without loss of pay, to act in representing a unit worker or workers on grievances or matters requiring representation. The Union shall designate the five (5) representatives under this section. The Union shall notify the City in writing of the names of the officers and representatives. Upon request, the City may approve release time for other bargaining unit members to represent a unit worker or workers under this Section. Only one (1) representative shall be entitled to release time under this section for any one (1) grievance or group of related grievances. Subject to the provisions of Section 3.2, release time shall be granted for the following types of activities:
  - 3.1.1 A meeting of the representative and a worker or workers in the unit related to a grievance.
  - 3.1.2 A meeting with Management
- 3.2 The Union agrees that the representative shall give advance notification to his/her supervisor before leaving the work location except in those cases involving emergencies where advance notice cannot be given. Release time is subject to the legitimate scheduling needs of the department.
- 3.3 Seven (7) Union representatives who are City employees, up to a maximum of two (2) employees from any department, shall be allowed a reasonable amount of time off without loss of pay for formal negotiation purposes. Preparation time for negotiations shall not be on release time without approval of the Human Resources Director. The Chapter Chair will not count towards the seven (7) total released employees or the maximum number of released employees from his or her department.
- 3.4 Nine (9) Union representatives, up to a maximum of two (2) employees from any department, shall be allocated up to one (1) hour per month time off without loss of pay for purposes of attending monthly Stewards' meetings. Workers shall normally be allowed to adjust their lunch period adjacent to this time.

## ARTICLE 4: DEFINITIONS

### 4.1 Definitions

4.1.1 A “temporary” or “contract” employee is a worker employed for a definite term of up to six months, although such temporary employee may be held over for up to three (3) additional months when the temporary employee is filling a vacancy created by leave without pay and the leave is extended beyond the initial fixed period.

A student intern may also be considered a temporary employee, provided he/she is not otherwise eligible for inclusion in the bargaining unit under the criteria listed in Article 1.

Recreation leaders and other recreation workers who commonly perform work at a level below a Recreation Supervisor may remain temporarily employed indefinitely. A temporary employee is not eligible for benefits provided in this agreement.

4.1.2 A “provisional” employee is a worker employed for a definite term of more than six (6) months, although such provisional employee may be held over beyond the initial term of employment as specified in Section 12.4.1. A provisional employee shall be employed and treated in all respects for the entire term of employment as a provisional employee, the same as a probationary employee.

4.1.3 A “probationary” employee is a worker who has not yet completed the probationary period, or any extension(s) thereof, as provided in this Agreement. A probationary employee is eligible for benefits provided in this Agreement, except as limited by Sections 6.1.5 and 6.1.8 of this Agreement.

4.1.4 A “permanent” employee is a worker who has satisfactorily completed the probationary period, or any extension(s) thereof. A permanent employee is eligible for benefits provided in this Agreement.

## ARTICLE 5: LAYOFF AND RE-EMPLOYMENT

### 5.1 Layoff

5.1.1 Whenever in the judgment of the City Council it becomes necessary in the interests of economy or because the position no longer exists, the City Council may abolish any position or employment in the competitive service, or may reduce the hours of any position. The decision to abolish a position or reduce the hours of any position shall not be subject to the grievance procedure contained in this Agreement.

- 5.1.2 It is agreed between the parties that attrition is the preferred method of accomplishing any necessary reduction in the work force.
  - 5.1.3 If a permanent reduction of hours is proposed for a particular classified position, the incumbent has the right to exercise any and all of the rights set forth in this Article. The incumbent may also choose to be laid off and receive the benefits contained in this article.
- 5.2 Notification of Layoff
- 5.2.1 Workers being laid off shall be given written notice from the City's Personnel Officer at least forty-five (45) calendar days prior to the effective dates of layoff. The layoff notice shall contain a statement of the effective date of layoff, a statement of "bumping rights" including the specific positions into which the worker may bump, and a statement of re-employment rights. Notice of layoff shall be given by personal service and the worker shall sign an acknowledgment of personal service; or by certified mail, return receipt, postage prepaid. The Union shall receive concurrent notice of individual layoff notices.
  - 5.2.2 Upon request, the Union shall be afforded an opportunity to meet with the City to discuss the circumstances requiring the layoff and any proposed alternatives.
- 5.3 Seniority
- 5.3.1. For the limited purposes of this Article 5, "length of service" means all hours in paid status including holiday, vacation, and paid leave, but does not include any hours compensated for overtime or standby, unpaid illness, unpaid industrial accident leave, or hours served as a temporary or contract employee in classifications other than the classification in which the worker is being laid off.
  - 5.3.2 In the event a worker reverts to a previously held classification, seniority shall include all time accrued previously in the lower classification, as well as all time accrued in the higher classification.
  - 5.3.3 No seniority credit shall be earned during periods of separation from service with the City, including suspension without pay as a result of disciplinary action.
- 5.4 Order of Layoff
- 5.4.1 All temporary employees in a particular classification will be laid off before any provisional, probationary or permanent employee in the classification.

- 5.4.2 All provisional employees in a particular classification will be laid off before any probationary or permanent employee in the classification.
- 5.4.3 All probationary employees in a particular classification will be laid off before any permanent employee in the classification.

## 5.5 Layoff Procedures

- 5.5.1 Except as otherwise provided, layoffs will be made in reverse order of seniority. The workers with the least time served in a classification shall be laid off first, with ensuing layoffs occurring in reverse order of length of service in the classification. If two workers have served the same time in the classification, then as between those two workers, the layoff will be based on total time of service with the City. If total time of service with the City is the same, then, as between those two workers, the layoff will be determined by a lottery.

## 5.6 Bumping Rights

- 5.6.1 A permanent employee who is designated for layoff, including a worker on probation following reclassification, transfer, or promotion from a permanent position, may elect, in lieu of layoff, to be reassigned to a position in a lateral or lower related classification within his/her department, or another department, provided that in order to displace the worker with less service the laid off worker must have held permanent status in the classification into which he/she is bumping.
- 5.6.2 When a senior employee chooses to bump into a position in a lateral or lower, related classification, said worker must accept the salary, hours, and working conditions of the position to which return is requested.
- 5.6.3 A bargaining unit worker requesting to bump into a classification as provided herein, must make such request to the Personnel Officer in writing within seven (7) calendar days of his/her receipt of written notice of layoff. Failure to comply with the deadline provided herein shall be deemed a waiver of the bumping rights provided in this Section 5.6.
- 5.6.4 Nothing herein shall preclude bumping between AFSCME and this bargaining unit.

## 5.7 Re-employment

- 5.7.1 The names of workers laid off shall be placed on a re-employment list in inverse order of seniority for a period of two (2) years from the date of layoff. The worker with the greatest seniority on the re-employment list shall be offered reinstatement when a vacancy occurs in a classification in which the worker held permanent status.

- 5.7.2 A laid off worker may refuse an offer of re-employment to a position for which he/she is qualified, however, refusal of two (2) offers of re-employment to the classification from which laid off shall automatically cause removal of the worker's name from the re-employment list and loss of any re-employment rights.
- 5.7.3 Any worker who accepts an offer of re-employment shall have his/her name removed from the re-employment list.
- 5.7.4 A worker who has been laid off and has been placed on a re-employment list shall be eligible, during the time the worker is on the re-employment list, to take promotional exams.
- 5.7.5 Offers of re-employment shall be made via the U.S. Mail Service, Certified Return Receipt, and shall include the specific position and/or hours being offered, the rate of pay, level of benefits, a current job description, a mechanism for acceptance or refusal of the offer of re-employment within the prescribed time limit, and a place for the laid off worker's signature. Failure to respond within ten (10) days from the date of service of offer of re-employment shall be deemed a refusal of that offer of re-employment.

The Union shall receive concurrent notice of each re-employment offer. Date of service is defined as the date marked on the certified mail return card, or the date the notice is returned by the postal service as undeliverable.

## 5.8 Miscellaneous Provisions

- 5.8.1 For the limited purpose of Article 5, permanent employees, including workers on probation following reclassification, re-employment, reinstatement, transfer, promotion, or demotion from a permanent position who are laid off shall be entitled to one (1) month severance pay and three (3) months of paid health insurance.
- 5.8.2 Workers appointed from a re-employment eligibility list shall have all rights accrued at the time of layoff restored including accrued sick leave, rate of vacation accrual and seniority, but excluding benefits to the extent compensation therefore has been received prior to re-employment. Severance pay, if any, shall not be repaid.



## ARTICLE 6: PERSONNEL ACTIONS

### 6.1 Probation

6.1.1 The probationary period shall be regarded as part of the testing process and shall be utilized for closely observing the worker's work, for securing the most effective adjustment of a new worker to a prospective position, and for rejecting any probationary worker whose performance is not satisfactory.

6.1.2 During the seventh pay period following employment, the worker shall receive a performance evaluation. Human Resources shall send a reminder notice of this deadline to the appropriate supervisor, with copies to the worker and City Manager.

6.1.3 All original appointments shall be subject to a probationary period of twelve (12) months for unit members. All promotional appointments shall be subject to a probationary period of six (6) months except for Police Department Communications Officers, who shall be subject to a probationary period of twelve (12) months. The Human Resources Director may, based upon the recommendation of the worker's supervisor, extend the probationary period not to exceed six (6) months if the worker marginally performed the necessary job functions and needs an additional six (6) months to bring performance to a satisfactory level. Total cumulative absences of two (2) weeks or more shall extend the review period by the corresponding duration of the absence.

6.1.4 At least one month prior to permanent appointment the City shall begin to review the work of the probationary employee to determine the following:

- a. certify him/her for the position;  
or
- b. extend the probation;  
or
- c. reject him/her for the position.

The City shall take action on this determination by the last day of the probation period by notifying the worker in writing. If the notification is delayed by more than five working days following the last day of probation, the worker shall become permanent.

6.1.5 If the service of a probationary employee is unsatisfactory, the worker will be notified in writing that he/she has been rejected for the permanent position. Said notice shall contain the reasons for rejection. The Human Resources Director shall, upon request, afford an interview in a timely fashion to the terminated worker for discussion of the reasons for termination. The worker may, upon request, be accompanied by a Union

representative. The interview shall not be deemed a hearing nor shall it obligate the City to reconsider or alter the termination action.

6.1.6 A worker deemed unsatisfactory for a position shall return to his/her prior classification and non-probationary status in that classification and to the pay step he/she would have had if not promoted, transferred or voluntarily demoted.

6.1.7 Departments may not shift job assignments as a reason in itself for placing a worker on probationary status.

6.1.8 The parties agree that probationary employees shall have the same rights as other workers under this Memorandum of Understanding, including full and complete access to the grievance procedure, except that workers who do not hold prior permanent status with the City shall have no right to review any disciplinary action or decision to unfavorably terminate the probation.

Workers who do hold prior permanent status shall have the right to appeal any disciplinary action, but not the decision to unfavorably terminate the probation.

6.1.9 A probationary period begins on the first day of work when the worker is selected to fill a permanent position.

## 6.2 Performance Evaluation

6.2.1 The City may, from time to time, develop reasonable guidelines that enable the supervisor to adequately evaluate the worker as to satisfactory job performance. Job performance reviews shall be conducted pursuant to regularly established and announced policies. The guidelines shall be in accordance with the job specifications for the position being reviewed.

6.2.2 Performance evaluations will be given to workers at least annually, but normally no more than twice a year, as scheduled by Management. Additional evaluations may be scheduled where there is documented evidence in preceding evaluations of the worker's inability to perform significant duties of the position. Management must complete performance evaluations by the date stated on the job performance form. After signing the evaluation to acknowledge receipt, the worker will have ten (10) working days in which to write a response. Signature of the evaluation will not constitute agreement with its contents.

Performance evaluations are not appealable through the grievance procedure but, in the event of disagreement over content, the worker may request a review of the evaluation with the next higher level of Management, in consultation with the Human Resources Director. For purposes of this review, the worker may be represented by the Union.

Decisions regarding evaluation appeal shall be made in writing within ten (10) working days following the meeting.

### 6.3 Performance Improvement Plans

When the performance of a worker falls below minimum standards established for a position a performance improvement plan may be developed. The worker has the right to have a Union representative present during the development of the performance improvement plan. Performance improvement plans must describe in detail the areas of deficiency, and contain a reasonable plan for improvement.

When used, Performance Improvement Plans shall be an integral extension of the job performance review process, and shall not be used, by themselves, for disciplinary actions.

### 6.4 Personnel Files

6.4.1 Human Resources shall maintain personnel records for each worker in the service of the City showing the name, title of position held, the department to which assigned, salary, changes in employment status, attendance records and such other information as may be considered pertinent. A worker is entitled to review his/her personnel file upon written request or may authorize, in writing, review by his/her Union representatives, with the exception of information obtained confidentially in response to reference inquiries. Upon written request by the worker, a worker or the Union shall be allowed copies of materials in a worker's personnel file relating to a grievance.

6.4.2 The City shall notify a worker of any adverse material placed in his/her personnel file if that material is or has not previously been reviewed with the worker. The worker shall have a reasonable time and opportunity to comment thereon.

6.4.3 In any disciplinary action the City may not rely upon any previous written warnings, notice of suspension or demotion, or written evaluation not contained in said file as justification for any personnel action which adversely affects the worker in question, but may rely on oral warnings not made a part of the file and issued within the preceding six (6) months. In the event a worker who has received written warnings or reprimands has completed twenty-four (24) months of work without further disciplinary action, his/her prior disciplinary record of similar instances, except for sustained findings of violations of the City's Anti-Harassment and Non-Discrimination Policy, shall no longer be relied upon in any determination which in any manner affects his/her employment status and shall be removed from the worker's personnel file upon request from the worker. In cases where a worker is suspended or demoted and such discipline is sustained, a record of such action shall be kept in the personnel file and

any such documentation supporting such action shall be kept in a separate file in the Human Resources Department.

- 6.4.4 Personnel files of individual workers are confidential information and shall be used or exhibited only for administrative purposes or in connection with official proceedings before the City Council. The City will only release information to creditors or other persons upon proper identification of the inquirer and acceptable reasons for the inquiry. Information then given from personnel files is limited to verification of employment, length of employment, any individual salary and benefit information, and any other information requested under the freedom of information act and deemed to be public information. Release of more specific information may be authorized in writing.

## 6.5 Promotional Opportunities

- 6.5.1 Promotional opportunities for classifications within the representation unit will be posted for at least ten (10) working days (Monday through Friday) prior to closing applications. Such postings shall include a description of the type of examination and screening process that will be used in filling the position. Any test given shall relate to the skills, knowledge, and abilities necessary to perform the job.
- 6.5.2 The top two (2) permanent bargaining unit members applying for promotional opportunities for classifications within the representation unit and who meet the minimum qualifications for the position will be interviewed regardless of the number of interviewees otherwise requested by the hiring department. When possible, the top two (2) permanent bargaining unit members applying for promotional opportunities outside of the representation unit and who meet the minimum qualifications for the position will be interviewed.
- 6.5.3 The City shall notify the worker applying for the promotion, in writing, of the City's decision to grant or deny the promotion upon request of the worker.

## 6.6 Reclassification

- 6.6.1 During the term of this Agreement, the City shall notify the worker concerned in case of contemplated change in job content as contained in the classification descriptions which were in effect at the beginning of the Agreement. The Union shall be notified in advance of any contemplated changes in classification descriptions and such changes shall be discussed with the Union, provided that the City shall have the final decision regarding job content. The Union shall be given a reasonable opportunity to meet and confer on the impact of any such changes on matters within the scope of representation.

- 6.6.2 Once each year, during the month of January, a worker may request in writing a re-evaluation of a Classification based on significant changes in job content or significant discrepancies between job content and the classification description. The request must contain justification. A statement by Management that a job re-evaluation request will be submitted with the department budget does not relieve a worker from the responsibility of submitting his/her own request in a timely manner. If meetings are held, the worker may request representation by the Union. The City will process the request and issue a recommendation within ninety (90) days. The City shall not agree to a change in the appropriate pay level for a job description until the Union has received a copy of the proposed change and has been given the opportunity to meet and confer with the City. Reclassifications shall become effective after City Council approval of the budget, retroactive to the first pay period of the fiscal year. Human Resources shall notify the Union at least ten (10) days prior to recommending a reclassification. Upon request, the Human Resources Director will meet and confer with the Union to determine whether the worker shall be subject to a probationary period. In cases where there is a dispute regarding the recommendation of the Human Resources Director, the recommendation may be appealed to the City Manager, whose decision shall be final and not subject to the arbitration provisions of Article 15, Grievance Procedure.
- 6.6.3 In conducting classification studies, the compensation figure calculated for each City shall consist of the following components: base salary, employer paid employee contributions to the retirement system, and deferred compensation contributions made by the employer on behalf of the employee
- 6.6.4 The reclassification procedure shall not be used for the purpose of avoiding use of the promotion or demotion procedures.
- 6.6.5 Salary step placement upon reclassification shall be in accordance with Article 7.4.1 (Effect of Promotion on Salaries).

## 6.7 Flexible Staffing

- 6.7.1 The term “flexibly staffed” position refers to those specifically designated positions within a classification series containing an entry level (I or Assistant) classification and journey level (II or Associate) classification and which can be filled at either of those two levels.

6.7.2 The currently identified flexibly staffed positions are:

- Accountant I/II
- Accounting Assistant I/II
- Assistant Planner/Associate Planner
- Child Care Teacher I/II
- Engineering Technician I/II
- Facilities Maintenance Technician I/II
- Librarian I/II
- Maintenance Worker I/II
- Water System Operator I/II

The City may post and fill the position at either the I /Assistant or II/Associate level. If the City fills the position at the I/Assistant level, promotion to the II/Associate level shall be considered after two years of service at the I/Assistant level, and after the most recent performance review reflects that acquired skills and experience have advanced to the journey level.

## ARTICLE 7: PAY RATES AND PRACTICES

### 7.1 Overall Wage Adjustments

Effective the beginning of the first full pay period following the later of July 1, 2022 or City Council adoption, the pay rates for employees in this representation unit shall be increased by an amount equal to three percent (3%).

~~Effective the beginning of the first full pay period after ratification of this Agreement by the membership and adoption by City Council, the pay rates for workers in this representation unit shall be increased by Four Percent (4.0%). The pay rates for workers in the representation unit shall be set forth in Appendix "B" to this Agreement.~~

~~7.1.2 Effective the beginning of the first full pay period following July 1, 2018, the pay rates for workers in this representation unit shall be increased by Three Percent (3.0%). The pay rates for workers in the representation unit shall be set forth in Appendix "B" to this Agreement.~~

~~7.1.3 Effective the beginning of the first full pay period following July 1, 2019, the pay rates for workers in this representation unit shall be increased by two and one half percent (2.5%). The pay rates for workers in the representation unit shall be set forth in Appendix "B" to this Agreement.~~

#### 7.1.4 Equity Adjustment

~~7.1.4.1 Effective the first full pay period after ratification of this Agreement by the membership and adoption by City Council, the pay rate~~

~~for the IT Specialist I/II shall be increased by Two and six tenths percent (2.6%).~~

#### 7.1.1 Lump Sum Payments

##### Year 1

Year 1 Payment - SEIU members who are City employees during the first pay period following the later of City Council adoption of the resolution authorizing amendments to the MOU or July 1, 2021 will receive a one-time lump sum payment of \$2,000. Employees may elect to have the \$2,000 Lump Sum Payment deposited into their Deferred Compensation Account (subject to IRS maximum contribution limits). If the employee does not elect to deposit the Lump Sum Payment into their Deferred Compensation Account or if the money cannot be lawfully deposited, it will be included in the employee's paycheck for the applicable pay period. The Parties intend and understand that this lump sum payment is non-pensionable and will not be reported to CalPERS. The parties also agree that this payment is intended to be specific to the pay period in which it is paid and is to be considered part of the regular rate for this pay period only.

##### Year 2

Year 2 Payment – SEIU members who are City employees during the first pay period following the later of City Council adoption of the resolution authorizing amendments to the MOU or July 1, 2022 will receive a one-time lump sum payment of \$2,000. Employees may elect to have the \$2,000 Lump Sum Payment deposited into their Deferred Compensation Account (subject to IRS maximum contribution limits). If the employee does not elect to deposit the Lump Sum Payment into their Deferred Compensation Account or if the money cannot be lawfully deposited, it will be included in the employee's paycheck for the applicable pay period. The Parties intend and understand that this lump sum payment is non-pensionable and will not be reported to CalPERS. The parties also agree that this payment is intended to be specific to the pay period in which it is paid and is to be considered part of the regular rate for this pay period only.

#### 7.1.2 Classification and Compensation Study

The parties agree to meet with the City's retained survey consultant, and review the consultant's recommended survey jurisdictions, benchmark classifications, and survey matches for a revised Total Compensation Survey to be completed by October 31, 2022. The union will have a minimum of two (2) SEIU members representatives attending each meeting on release time. Meetings shall begin no later than September 1, 2022 and shall continue on a monthly basis, subject to any agreement to modify the schedule.

The Parties intend the Total Compensation Survey to provide information to support consideration of market-based equity adjustments for individual classifications for successor MOU negotiations. Negotiations will consider both the total compensation survey results and the City's Financial recovery, including:

- Impact on assessed values for the 2021 and 2022 rolls
- TOT recovery, considering 2019 baseline.

## 7.2 Step Increases

Merit advances from the first salary step and subsequent steps shall be granted at one (1) year intervals if the affected worker has demonstrated continued competent service. For the purpose of determining step time requirements, time will commence on the first day of the month coinciding with or following entrance onto a salary step. Step increases shall be effective on the first day of the payroll period in which the time requirements have been met.

## 7.3 Application of Rates

7.3.1 Workers occupying a position in the competitive service shall be paid a salary or wage within the range established for that position's class under the pay plan as provided. The minimum rate for the class shall normally apply to beginning workers. However, subject to the approval of the Personnel Officer, the department head may hire beginning workers who are especially qualified by their training or by their previous experience at any step in the range.

7.3.2 In the event that a newly hired worker is placed above Step A on the salary schedule due to recruitment problems, as opposed to the conditions in 7.3.1 above, incumbents in that classification who have been placed on a lower step of the salary schedule will be moved to the same step on the salary schedule as the newly hired worker, and all such workers will be allowed to move to the next step in six months.

## 7.4 Effect of Promotion, Demotion or Transfer on Salaries

### 7.4.1 Promotion

Upon promotion, a worker's salary shall be adjusted as follows:

7.4.1.1 If the first step in the salary range for the worker's new position is at least five percent (5%) greater than the worker's current salary range, the worker shall be moved to the first step of the new salary range.

7.4.1.2 If the first step in the salary range for the worker's new position is less than five percent (5%) greater than the worker's current salary range, the worker shall be moved to the step which would



provide at least a five percent (5%) increase in salary.

7.4.1.3 If no step in the salary range for the new position would provide the worker with at least a five percent (5%) salary adjustment, the worker shall be moved to the top step of the new salary range.

7.4.2 Demotion

Upon demotion of a worker with permanent status in his/her current class, his/her salary shall be adjusted to the highest step in the new class not exceeding the salary received in the former class.

7.4.3 Transfer

Upon transfer, the salary shall remain unchanged.

7.5 Bilingual Differential

7.5.1 Workers who are assigned to job duties requiring bilingual skills are eligible to receive Sixty-Five Dollars (\$65.00) each pay period for the use of bilingual skills in job duties arising during the normal course of work.

7.5.2 Eligibility for the bilingual pay differential shall be determined by the Personnel Officer on the basis of a proficiency test developed and administered by the City.

7.5.3 Bilingual skills shall not be a condition of employment except for workers who are hired specifically with that requirement. If a worker is hired under this provision, that requirement shall be included in the initial appointment letter.

7.5.4 The City retains the right to discontinue the bilingual differential for any individual worker when bilingual services are no longer required, provided the City gives the exclusive representative ten (10) days' notice prior to such revocation, in order to allow the opportunity for the parties to meet and consult.

7.5.5 No employee shall be required to use bilingual skills who is not compensated under this section.

7.6 Call Back Pay

7.6.1 Any worker who is required by the City to report to their normal work location on a day when the worker has not been scheduled, or any worker called back to work after the worker has completed his or her regular work day and left the worksite, shall be entitled to a minimum of two (2) hours of compensation at the flat rate of Twenty-Five Dollars and Thirty-Five

Cents (\$25.35) per hour or one and one-half times their regular rate of pay, whichever is greater. Call back pay shall not apply where the City requires a worker to remain at the worksite after the completion of his or her regular work shift.

7.6.2 Employees who do not return to their normal work location, but who are required to work remotely, are not eligible for call back pay, but shall be paid for time actually worked at one and one-half times their hourly rate of pay.

7.6.3 Payment for call back may be at the cash rate specified in Section 7.6.1 above or in compensatory time off at the rate of one and one-half hours for each hour worked, at the worker's option. Prior to the end of the pay period, the worker shall designate, on the appropriate City form, his/her choice of either compensation at the flat dollar rate or one and one-half times their regular rate of pay, whichever is greater or compensatory time off.

#### 7.7 Standby Pay

7.7.1 A worker performing standby duty outside the worker's regular work shift shall be compensated at the rate of Three Dollars and Twenty Five Cents (\$3.25) per hour for each hour the worker is assigned to standby duty. A worker shall not combine standby pay with call back pay or overtime.

#### 7.8 Rest Period Following Emergency Work

7.8.1 Bargaining unit employees in the Police or Public Works Departments shall be entitled to eight (8) hours of rest period when they work more than sixteen (16) hours within a twenty-four (24) hour period beginning with the time the worker reports to work.

7.8.2 Prior to working over sixteen (16) hours within a twenty-four (24) hour period and triggering the eight (8) hour rest period the employee must get approval from the Department Director or his/her designee.

7.8.3 Rest periods are unpaid unless the rest period overlaps the employee's regular work shift in whole or in part. The employee will be paid for that portion of the rest period that overlaps the employee's normal working shift. The employee will be required to work the remainder of their normal working shift that does not overlap with the eight (8) hour rest period unless they request and are approved for leave. The employee will not be paid for the time between expiration of the rest period and his/her normal work shift.

7.8.4 This section shall not apply in emergency situations.

#### 7.9 Working Out of Classification

7.9.1 The term “working out of classification” is defined as a Management authorized assignment to perform work on a temporary basis wherein significant duties are performed by a worker holding a classification within a lower compensation range. The employer shall notify workers in advance of making such assignments. Pay for working out of classification shall be as follows:

7.9.1.1 A worker performing duties associated with a higher position, whether filled or unfilled, on an out of classification basis will receive acting pay of five percent (5%) for the hours worked in that capacity.

When the Department Head anticipates that the out of classification assignment will be for a period of 240 hours or more, the worker will receive the pay rate of the higher classification beginning with the start of the assignment. If such a determination has not been made by the end of the 240 cumulative hours worked in the higher classification, the worker shall receive the pay rate of the higher classification.

7.9.2 Out of classification provisions do not apply to work assignments performed in connection with declared conditions of public peril and/or disaster.

## 7.10 Night and Weekend Differential

Workers in the Library assigned to work hours between 5:00 P.M. and 8:00 A.M. weekdays or between Friday from 5:00 P.M. to Monday 8:00 A.M. shall be compensated for night and weekend differential at five percent (5%) above the worker’s base pay.

Workers in the Police Department assigned swing, midnight, relief or day shift on the weekend shall be compensated for night and weekend differential at five percent (5%) above the worker’s base pay. Overtime hours shall not be used to qualify for weekend or night shift differential.

## 7.11 Court Appearances

Workers required to appear in Court during off-duty hours to testify regarding matters arising out of the worker’s employment with the City, shall receive a minimum of four (4) hours pay at time and one-half (1.5). The City reserves the right to require the worker to wait to testify at their work location and perform duties as assigned while waiting to testify, provided the Court consents. If the Court requirement expires prior to the expiration of the four (4) hour minimum, the employee shall be released.

This section does not apply in situations where the worker is held over after or called in prior to his or her regular shift as long as the period is adjacent to the normal work shift. In these situations, standard overtime provisions shall apply.

## ARTICLE 8: HOURS AND OVERTIME

### 8.1 Hours of Work

#### 8.1.1 Regular Work Schedules

- a. The regular work schedule for all workers except those on a flexible schedule such as a 4/10, or 9/80
- b. schedule, shall consist of forty (40) hours within a seven (7) day work week and is five consecutive days served in units of eight (8) hours. For this schedule, the workweek begins Sunday midnight and ends Saturday at 11:59 P.M.
- c. A 4/10 work schedule shall be four (4) days served in units of ten (10) hours within a seven (7) day workweek. For this schedule, the workweek begins Sunday midnight and ends Saturday at 11:59 P.M.
- d. A 9/80 work schedule shall be nine (9) days served in one (1) unit of eight (8) hours and eight (8) units of nine (9) hours over a two week pay period. For this schedule, the workweek shall begin exactly four (4) hours after the start time of the day of the week which is each employee's regular alternate day off.

8.1.2 Part-time Workers. Workers who work less than the regular week and day as set forth above shall be designated as part-time and shall have hours scheduled by the appropriate supervisor and approved by the City's Human Resources Director.

8.1.3 Lunch Periods. All workers working a work shift of six (6) hours or more, except Communications Officers, City Service Officers assigned to patrol or daytime parking enforcement, and Code Enforcement Officers shall observe an unpaid lunch period of not less than thirty (30) minutes nor more than sixty (60) minutes. Lunch periods shall be scheduled with the approval of the department director. When required by the needs of the department, or requested by the worker and authorized by the Department, Communications Officers, City Service Officers assigned to patrol or daytime parking enforcement, Community Service Officers, and Code Enforcement Officers shall take an "on duty" lunch period which shall be counted as time worked.

Workers assigned to a shift of at least five (5) but fewer than six (6) hours may request to observe a regularly scheduled unpaid lunch period of not less than thirty (30) minutes nor more than sixty (60) minutes, which shall

not be unreasonably denied. Lunch periods shall be scheduled with the approval of the department director or designee.

8.1.4 Rest Periods. One (1) fifteen (15) minute rest break with pay shall be provided to workers for each four (4) hours of service. Rest periods and lunch periods may not be aggregated and used to extend the lunch period or shorten the work day.

## 8.2 Overtime

### 8.2.1 Definition.

- a. Overtime for workers is defined as any time worked in excess of forty (40) paid hours in any work week as defined in section 8.1.1.
- b. For Communications Officers, overtime shall also include any hours worked outside their normally assigned shift.

Overtime shall be compensated pursuant to Section 8.2.3. All overtime must be authorized and approved in advance by the department director or designee.

8.2.2 Modified Schedules. At the request of either the worker or department director, the department director may approve a schedule of more than eight (8) hours per day without overtime compensation. Such a work schedule must be consistent with the regular work schedules defined in Section 8.1.1.

8.2.3 Overtime. Overtime may be assigned on a required basis or requested by the worker and approved by the department director. Overtime shall be compensated at the rate of one and one-half (1.5) times the worker's regular rate of pay or in the form of compensatory time at the rate of one and one-half (1.5) hours for each hour worked, at the worker's option except when the worker's choice of compensatory time would interfere with a department's ability to recover the cost of the overtime.

The parties agree to meet and confer over ways to address the constructive receipt issue with regard to compensatory time, with a goal of implementing changes no later than November 2017.

8.2.4 Compensatory Time. A worker may accumulate a maximum of one hundred sixty (160) hours of compensatory time. Compensatory time may be used when the services of a worker are not needed for the efficient functioning of his/her department, and must be approved in advance by the department head. Once a worker has reached the limits of compensatory time in this section he/she shall receive cash at the overtime rate for all overtime worked.

Upon termination, all unused compensatory time shall be paid off at the final rate of pay received by the worker, or the average regular rate received during the last three (3) years of the worker's employment, whichever is higher.

### 8.3 Work Schedule

All work schedule and flexible time work schedule arrangements presently in effect shall continue. If the City proposes to change the work schedule of a classification the Union shall be notified at least ten (10) working days in advance and given an opportunity to meet and consult over such proposed changes prior to implementation.

## ARTICLE 9: UNIFORMS

9.1 The City will provide uniforms, raingear, coveralls or shop coats when necessary for all Public Works, Engineering, applicable Building and Planning Department, and Police Department workers, consistent with existing practice.

9.2 Communications Officers, Lead Communications Officers, Records Personnel, Community Service Officers, and Parking Enforcement Officers shall upon initial appointment be provided required uniforms as determined by the Chief of Police, and thereafter receive Six Hundred Dollars (\$600) per year uniform allowance. As soon as practicable, payment shall be made in the amount of \$23.077 per biweekly pay period. If an employee is on unpaid leave for a period of one (1) full pay period or more, the employee will not receive uniform allowance for that period.

The City will provide uniform jackets for Community Service Officers and Parking Enforcement Officers whose work is primarily outdoors. Jackets that are worn or damaged in the course of work will be routinely replaced by the City. It will be the employee's obligation to replace lost or misplaced jackets.

If any other worker is required to wear a uniform during the life of this Memorandum of Understanding, the City will meet and confer with the Union concerning the establishment of an equitable uniform allowance.

9.3 On presentation of appropriate receipts, the City shall reimburse workers who are required by the City to wear safety shoes/boots for up to Two Hundred Eighty-Five Dollars (\$285) toward the cost of no more than three (3) pairs of OSHA approved safety shoes/boots per year. Workers in the Public Works Department assigned to the tree crew shall be reimbursed for up to Three Hundred Forty Dollars (\$340) toward the cost of no more than three (3) pairs of OSHA approved safety shoes/boots per year. Shoe repair and resoling are reimbursable under this provision. Shoes/boots purchased under this provision are for the use of the worker exclusively. So long as all required documents are submitted, reimbursements will be processed within two (2) pay periods following supervisory approval.

~~On presentation of appropriate receipts, the City shall reimburse workers who are required by the City to wear safety shoes/boots for up to Two Hundred Eighty Five Dollars (\$285) toward the cost of no more than three (3) pairs of OSHA approved safety shoes/boots per year. Workers in the Public Works Department assigned to the tree crew shall be reimbursed for up to Three Hundred Forty Dollars (\$340) toward the cost of no more than three (3) pairs of OSHA approved safety shoes/boots per year. Shoe repair and resoling are reimbursable under this provision. Shoes/boots purchased under this provision are for the use of the worker exclusively.~~

9.4 Employee clothing seriously damaged or destroyed in conjunction with employment duties will be reasonably replaced by the City.

9.5 Workers in the Public Works Department shall be permitted to wear shorts, provided that supervisory approval has been given as to their appropriateness in terms of style, location and safety.

9.6 The City shall reimburse Equipment Mechanics in the Maintenance Division who, as a condition of employment, are required to provide their own tools and equipment. Reimbursement will be made for tools that the worker selects to purchase, or for tools required to be added to the inventory in order to carry out his or her duties. Reimbursement will be made on submission of receipts, but no more than twice per fiscal year. The reimbursement shall be administered in accordance with Maintenance Division policy. Effective July 1, 2016, the City shall reimburse a maximum of one thousand four hundred dollars (\$1,400) per fiscal year.

9.6.1 Tool Inventory. To qualify for reimbursement pursuant to paragraph 9.6.3 below, Equipment Mechanics must provide an inventory of tools which are maintained on City property. The inventory must include the following for each tool: (1) manufacturer and part number (2) approximate purchase date; and (3) a photo of the tool.

9.6.2 The City will cover the replacement of inventoried tools and equipment which are lost on City property due to (1) theft or (2) damage due to normal wear and tear (e.g., accident or fire). Tools left on City property must be properly secured when not in use. No reimbursement will be permitted for loss or damage attributable to the negligence or willful misconduct of the employees.

9.6.3 Requests for replacement tools will be made through the normal tort claim process.

## ARTICLE 10: HOLIDAYS

### 10.1 Fixed Holidays

Except as otherwise provided, workers within the representation unit shall have the following fixed holidays with pay:

New Year's Day	January 1
Martin Luther King Day	Third Monday in January
Washington's Birthday	Third Monday in February
Memorial Day	Last Monday in May
Independence Day	July 4
Labor Day	First Monday in September
Veterans Day	November 11
Thanksgiving	Fourth Thursday in November
Day after Thanksgiving	Fourth Friday in November
Christmas Eve	December 24
Christmas Day	December 25

- 10.1.1 Except for Communications Dispatchers and Senior Communications Dispatchers, in the event that any of the aforementioned days, except December 24, falls on a Sunday, the following Monday shall be considered a holiday. In the event that any of the aforementioned days falls on a Saturday, the preceding Friday shall be considered a holiday. In the event that December 24 falls on a Sunday, then the preceding Friday shall be considered a holiday.

Bargaining unit members in the Communications Dispatcher and Senior Communications Dispatcher classifications shall observe Independence Day, Veterans Day, Christmas Day, Christmas Eve and New Year's Day on the actual date of the holiday.

- 10.1.2 Pay for Fixed Holidays. All full-time workers shall be paid eight (8) hours pay at their regular straight time base hourly rate for all fixed holidays as defined herein. All part-time workers shall be entitled to holiday leave with pay for the number of hours each holiday based on the number of hours per week such part-time worker is indefinitely assigned to work in the employee's regularly scheduled part-time position. An employee who is scheduled to work on a fixed holiday, and who does not work shall use vacation or other appropriate paid/unpaid leave to make up any difference between the holiday and his or her regularly scheduled shift. An employee will not be paid for more than his or her regular day's pay for any holiday when he or she does not work.

Pay for fixed holidays may not be taken as compensatory time off.

- 10.1.3 Work on Fixed Holidays.
- a. Except for Communications Dispatchers and Senior Communications Dispatchers, any full-time worker required to work on a fixed holiday shall be paid time and one-half for such work in addition to his/her holiday pay. Work on a fixed holiday beyond the number of hours in the regular shift being worked on the holiday shall be compensated at double time.
  - b. Except for Communications Dispatchers and Senior Communications Dispatchers, any part-time worker required to work on a fixed holiday shall be



paid time and one-half for such work in addition to his or her holiday pay. Work on a fixed holiday beyond the number of hours in a regular shift shall be compensated at time and one-half.

Part-time Communications Dispatchers shall be treated the same as full-time workers with regard to double time pay on a holiday.

- c. Bargaining unit members in the Communications Dispatcher and Senior Communications Dispatcher classifications required to work on a fixed holiday shall be paid as follows:

- 1. Holidays on Employee's Regular Workday. A Communications Dispatcher or Senior Communications Dispatcher required to work on a fixed holiday which falls on his or her regular workday shall be paid time and one-half for such work in addition to his or her regular pay. Work on a fixed holiday beyond the number of hours in the regular shift being worked on the holiday shall be compensated at double time. Employees who work their regular shift on a fixed holiday shall not receive additional holiday pay.

Example 1, if a Communications Dispatcher works a full (10-hour) shift on a holiday which falls on his or her regular workday, he or she would be paid a total of 25 hours (10 hours plus 10 hours at time and one half).

Example 2, if a half-time Communications Dispatcher works a full (10-hour) shift on a holiday which falls on his or her regular workday (scheduled 5 hours), he or she would be paid a total of 22.5 hours [5 hours plus 5 hours at time and one half (for the 5 hours of their regular shift) plus 5 hours at double time (for time beyond their regular shift).]

- 2. Holidays on an Employee's Regular Day Off. A Communications Dispatcher or Senior Communications Dispatcher required to work on a fixed holiday on his or her regular day off shall be paid double time for such work in addition to eight (8) hours of holiday pay (pro-rated for part-time workers,)

For example, if a full-time Communications Dispatcher works a full (10-hour) shift on a holiday which falls on his or her regular day off, he or she would be paid a total of 28 hours (8 hours holiday pay plus 10 hours at double time.)

- 10.1.4 A full time worker who is regularly scheduled to work more than eight (8) hours on a holiday may make up the additional hours using vacation, compensatory time, floating holiday time, or unpaid time. In addition, with the approval of his or her supervisor, and subject to the operational needs of the City, a worker may work additional straight time hours during the same workweek to make up the difference.

A part-time worker who is regularly scheduled to work on a holiday for more hours than they receive in holiday time may use vacation, compensatory time, floating holiday time, or unpaid time to complete their regularly scheduled workweek. In addition, with the approval of his or her supervisor, and subject to the operational needs of the City, a worker may work additional straight time hours during the same workweek to make up the difference. [For example, a worker who is regularly scheduled to work twenty (20) hours per week receives four (4) hours of holiday pay for the July 4 holiday but is scheduled to work six (6) hours on the day the holiday is observed. The worker may use two (2) hours of vacation to complete his or her regular workweek.]

- 10.1.5 The City Manager, or designee may close individual worksites or all non-essential City operations on non-City holidays (for example, during the week between Christmas and New Years). In that event, affected employees shall be encouraged to take time off, however, it shall not be a requirement. Employees electing to take time off may choose to take vacation, compensatory time, floating holiday time or unpaid time during the closure period.

Employees who choose to work on a City closure day may be assigned to perform duties outside of their normal job duties. Any assigned duties must be reasonable in nature. For example, a Public Works employee may be assigned to perform clerical duties such as file review in City Hall. However, a clerical employee may not be assigned to operate heavy machinery (e.g., a chain saw).

The City Manager will notify employees of any closure between Christmas and New Years on or before the fourth Thursday in November immediately preceding the closure.

## 10.2 Floating Holiday Time

————For calendar year 2021, workers shall receive thirty-four (34) floating holiday hours off with pay, credited on the first pay period following City Council adoption of the resolution authorizing amendments to the MOU. Workers hired after the first pay period following City Council adoption shall receive a pro-rated amount of floating holiday hours for the remainder of the calendar year.

For calendar years ~~2018, 2019, and 2020~~2022 and 2023, workers shall annually receive thirty-four (34) floating holiday hours off with pay, credited on the first pay period of the year. Workers hired after the first pay period of the year shall receive a pro-rated amount of floating holiday hours for the remainder of the calendar year.

The following conditions will apply to such floating days off:

- 10.2.1 Workers shall request a floating day off in accordance with normal vacation time off request procedure.
- 10.2.2 Floating days off must be used during or prior to the end of the twenty-sixth (26<sup>th</sup>) pay period of the year in which it was credited or be forfeited.

- 10.2.3 If a worker fails to take a day off as scheduled, the day off so scheduled will be forfeited, unless a mutually agreeable alternative day off is arranged.
- 10.2.4 Any floating day off for workers who work less than full-time or less than a full year shall be prorated on the basis of hours worked as compared to full-time employment.
- 10.2.5 Floating holiday balances remaining at the time of separation will be forfeited.

## ARTICLE 11: VACATIONS

11.1 Each worker shall be entitled to an annual paid vacation, accrued as follows:

11.1.1 For full-time workers:

Less than three (3) years of service - 88 hours per year.

Three (3) years of service through five (5) years of service - 104 hours per year.

Six (6) years of service through ten (10) years of service - 136 hours per year.

Eleven (11) years of service through fifteen (15) years of service - 152 hours per year.

Over fifteen (15) years of service - 176 hours per year.

11.1.2 For permanent part-time workers: a proportional equivalent based on the assigned number of hours worked per week as compared to those worked by a full-time worker.

11.2 Maximum Accrual

Vacation may be accrued up to a maximum of three hundred thirty-six (336) hours. The maximum accrual for part time employees shall be a proportional equivalent. After reaching said maximum, the worker must take time off or accrual will be frozen. Upon separation, there will be no payment for hours in excess of the maximum accrual.

11.3 Scheduling

The department head shall determine the vacation schedule considering the needs of the department, specifically with regard to the worker's assigned duties and the

worker's desires. Use of vacation is subject to the advanced approval of the Department Director or designee. Any and all vacation granted pursuant to this Article shall be granted at time or times as will not reduce the number of employees below that which is reasonably necessary for the efficient conduct of the public business of such department, division or work group. Vacation time requested shall not be unreasonably denied.

11.4 Payment on Separation

Accrued vacation time up to the maximums described in Section 11.3 above shall be paid to a worker permanently separated from City service,

11.5 Vacation Cashout

A worker may cash out vacation leave in accordance with the Vacation Cashout Policy, attached hereto as Appendix "E".

11.6 Illness During Scheduled Vacation

A worker who, during a scheduled vacation period, becomes ill or injured, shall be entitled to have the remaining time off coded as sick leave, under the following conditions:

- a. The worker otherwise qualifies for sick leave as provided by this Agreement and has sufficient sick leave to cover the period; and,
- b. The worker's illness or injury is verified by a statement from an accredited medical doctor for each such day of illness for which leave is requested.

If vacation time has been deducted for the period covered under this Section, and the use of sick leave has been approved, the time will be credited back and sick leave used in its place.

ARTICLE 12: LEAVE PROVISIONS

12.1 Sick Leave

12.1.1 Accrual Rates. The City shall provide each worker with paid sick leave at the rate of eight hours per month, earned on a biweekly basis and computed as follows:

12.1.1.1 Full-time workers may accrue up to a maximum of one thousand four hundred forty (1,440) hours for full time workers, and a proportional equivalent for part-time employees.

12.1.2 Use of Sick Leave. Sick leave shall be allowed and used in cases of actual personal sickness or disability, medical or dental treatment, or as authorized for other necessary health reasons. Up to six (6) days per year of sick leave may be used in cases of actual sickness or disability, medical or dental treatment of members of the worker's immediate family.

If a worker is scheduled to work on a designated City holiday, and subsequently calls in sick, the worker shall not receive holiday pay.

12.1.3 Abuse Enforcement. The City shall be obligated to monitor all sick leave use, and shall take appropriate actions to ensure that benefits are paid out only for use as authorized in Section 12.1.2.

12.1.3.1 Any worker who does not have an accrued sick leave balance and who does not otherwise qualify under the provisions of this Article 12, shall not be paid for any day of sick leave called in, whether genuine or not.

12.1.3.2 Management has the authority to monitor potential sick leave abuse and patterns of abuse, and when there is a reasonable basis for suspecting such abuse, may require medical verification as a condition for payment of sick leave.

12.1.4 Compensation for Accumulated Sick Leave.

12.1.4.1 Resignation. A resigning worker, who was hired into the unit prior to May 4, 2010 and who has fifteen (15) or more years of continuous service shall receive compensation for up to fifteen percent (15%) of his/her accumulated sick leave balance up to a maximum of five hundred (500) hours. Such compensation shall be based on the worker's rate of pay on his/her last day paid service to the City.

12.1.4.2 Retirement. A worker who was hired into the unit prior to May 4, 2010 and who retires under PERS from the City may elect to receive cash compensation for fifteen percent (15%) of his or her accumulated sick leave balance, up to a maximum of one thousand three hundred sixty (1,360) hours, based upon the worker's rate of pay on his or her last day of paid service to the City, or may convert their sick leave balance, up to a maximum of one thousand three hundred sixty (1,360) hours, to retirement health credits at the rate prescribed in Section 12.1.4.3. Workers may combine any of the above two options.

12.1.4.3 Retirement Health Credit Conversion. A worker who was hired into the unit prior to May 4, 2010 and who has a minimum of five (5) years of continuous service who elects to convert accumulated sick leave to retirement health credits upon

retirement from the City may do so under the following schedule:

Five (5) years of service to fifteen (15) years of service: eight (8) hours of sick leave for each retirement health credit, with any remainder being rounded to the next higher credit;

Fifteen (15) years of service to twenty (20) years of service: six (6) hours of sick leave for each retirement health credit, with any remainder being rounded to the next higher credit;

Over twenty (20) years of service three (3) hours of sick leave for each retirement health credit, with any remainder being rounded to the next higher credit.

If this election is made, the retirement health credit calculated shall not exceed the highest HMO health plan premium as may be in effect at such time such credit is applied. Election shall be made at the time of retirement.

- 12.1.4.4 Layoff. A worker who was hired into the unit prior to May 4, 2010 and who has been laid off may select as compensation for accumulated sick leave one month of paid health insurance for each unit of retirement health credit. After the health insurance benefit paid under Section 5.8.1 has been exhausted, up to a maximum of forty-eight (48) hours of the accrued sick leave balance may be converted to retirement health credits at the rate of one (1) unit for every eight (8) hours of accumulated sick leave with any remainder being rounded to the next higher credit.
- 12.1.5 Double Coverage. Workers who qualify for the retirement health credit conversion may elect double coverage at the rate of two (2) units for every month of paid health insurance.
- 12.1.6 Family Coverage. Workers who qualify for the retirement health credit conversion may elect family coverage at the rate of three (3) units for every month of paid health insurance.
- 12.1.7 Transfer of Sick Leave for Catastrophic Illness. Transfer of sick leave for catastrophic illness is designed to assist workers who have exhausted sick leave due to a catastrophic illness, injury or condition of the worker. This policy allows other workers to make voluntary grants of time to that worker so that he/she can remain in a paid status for a longer period of time, this partially ameliorating the financial impact of the illness, injury or condition.

A catastrophic illness is defined as an illness which has been diagnosed by a competent physician, requiring an extended period of treatment or

recuperation, and which has a significant risk to life or life expectancy. Confirmation of the condition and prognosis by a health care provider chosen by the City may be required.

Human Resources will discuss with the Union or their designated representative an appropriate method of soliciting contributions from coworkers. The contributions shall be submitted to Human Resources and Human Resources will process the contribution list in the order established. Any worker shall be allowed to contribute a maximum of eighty (80) hours of sick leave from their accrued sick leave balance to another full-time or permanent part-time worker in the City who is suffering from a catastrophic illness and has exhausted his or her own sick leave, provided, however, they have maintained a positive sick leave balance of forty (40) hours or more following the donation. Once the contribution is made it cannot be rescinded.

Upon return to work, a worker may bank any remaining hours that have been contributed up to a maximum of forty (40) hours. If the contribution list has not been exhausted, the contributing workers will be notified that their contribution was not required and the balance restored.

Determination of employees eligible for the program shall be made by the Human Resources Director, whose decision shall be final.

## 12.2 Long Term Disability

- 12.2.1 Should any illness or injury extend beyond forty-five (45) calendar days, the City will ensure continued payment to the worker at 66.67 percent of salary, up to a maximum as provided in the long-term disability policy. The amounts paid shall be less any payments received from either Workers' Compensation or retirement. During the first year of disability and so long as no retirement determination has been made by the City, the worker will be entitled to continued City paid health insurance, AD&D, dental and life insurance benefits, providing that the employee continues to pay the worker share of the benefit cost, where applicable. Accrued leave earned shall only continue for periods during which the worker is utilizing accrued leave time. At the end of 365 calendar days from the date of illness or injury or unless previously retired, should the not be able to return to work, the worker will be permitted to continue to participate in City paid health insurance, AD&D, dental and life insurance benefits. However, the worker will be required to pay 100% of any premiums.
- 12.2.2 Workers who have a sufficient amount of sick leave time may, at the worker's option, use sick leave on a hour-for-hour basis to delay the start of the long term disability plan. The long term disability plan would start upon the exhaustion of sick leave. The City procedures which allow for follow-up of a worker who has been out on an extended disability shall apply to workers under this section.

## 12.3 Personal Business Leave

- 12.3.1 A worker shall be entitled to a maximum of three (3) days per calendar year for Personal Business Leave without loss of pay. Such leave shall be deducted from accrued sick leave.
- 12.3.2 Personal Business is defined as business of urgent and compelling importance which cannot be taken care of outside of normal working hours and which is not covered under other leave provisions of this Memorandum of Understanding.
- 12.3.3 A worker shall notify the department head two (2) days before taking this leave, unless an emergency exists which prohibits the worker from providing such advance notice.
- 12.3.4 Personal Business Leave may only be used for personal business of urgent and compelling importance, and may not be used for recreational purposes, extension of holidays or vacation, work stoppages, or for matters of purely personal convenience.
- 12.3.5 At the discretion of the supervisor, a worker may also use vacation, compensatory time off or floating holiday time to cover absences of an emergency nature. No request shall be unreasonably denied.

## 12.4 Leave Without Pay

- 12.4.1 Vacancies created as a result of leave without pay may be filled in the following manner:
  - a) By temporary employees for a maximum of six (6) months;
  - b) By provisional employees.

If a leave is extended beyond the initial fixed period, temporary employees may be held over for up to three (3) months (for a total term of employment of nine (9) months) in a temporary capacity. Provisional employees may be held over if a leave is extended, or, in cases where the position is vacated, for the duration of the recruitment period.

- 12.4.2 Leaves of absence without pay may be granted in cases of personal emergency or when such absences would not be contrary to the best interest of the City.



12.4.3 Requests for leaves of absence without pay must be written and submitted to the department director and Human Resources. The Human Resources Director may grant a permanent employee leave of absence without pay for a period not to exceed one (1) year, during which time no benefits and no seniority credit will accrue. Approval shall be in writing and a copy filed with the Human Resources. Upon expiration of a regularly approved leave, or within five (5) working days after notice to return to duty, the worker shall be reinstated in the position held at the time the leave was granted. Failure on the part of a worker on leave to report promptly at its expiration, or within three (3) working days after notice to report to duty, may be deemed notice of resignation and/or cause for disciplinary action.

## 12.5 Jury Duty and Subpoenas

12.5.1 A worker required to report for jury duty or to answer a subpoena as a witness on behalf of the City, provided the witness has no financial interest in the outcome of the case, shall be granted a leave of absence with pay from his/her assigned duties until released by the court, provided the worker remits to the City all fees received from such duties other than mileage or subsistence allowances within thirty (30) days from the termination of jury service.

12.5.2 This leave of absence with pay shall extend to workers' whose regular shift is a shift outside of the hours of 8:00 A.M. to 5:00 P.M., so that such workers shall not be required to work their regular shift on a day in which they perform jury duty or respond to a subpoena.

12.5.3 When a worker returns to complete a regular shift following time served on jury duty or as a witness, such time falling within work shift shall be considered as time worked for purposes of shift completion and overtime computation. In determining whether or not a worker shall return to his/her regular shift following performance of the duties above, reasonable consideration shall be given to such factors as travel time and a period of rest.

## 12.6 Military Leave

Military leave of absence shall be granted and compensated in accordance with all applicable laws. Workers entitled to military leave shall give the appointing power an opportunity, within the limits of military regulations, to determine when such leave shall be taken.

## 12.7 Bereavement Leave

A worker shall be allowed regular pay for not more than three (3) working days when absent because a death has occurred in the immediate family. For purpose of bereavement leave, members of the immediate family shall be limited to mother, stepmother, father, stepfather, mother-in-law, father-in-law, grandmother,

grandfather or grandchild of the worker, or spouse, brother, stepbrother, sister, stepsister, domestic partner or dependent of the worker.

To qualify for bereavement leave in the event of the death of a domestic partner, a declaration of domestic partnership must have been filed by the worker with Human Resources prior to the request to utilize such leave.

Employees may use other appropriate leave for bereavement purposes for relations not included above provided such leave is approved in advance by the Department Director.

## 12.8 Maternity and Parental Leave

Workers are entitled to leaves of absence for maternity, parental bonding, and pregnancy-related disability. All such leave of absence shall be granted and compensated in accordance with state and federal laws covering these topics, including the California Family Rights Act.

## 12.9 Miscellaneous Leave Provisions

12.9.1 Leaves of absence without pay which exceed four (4) weeks and are for leaves other than military, shall not be included in determining seniority.

12.9.2 At the conclusion of a leave of absence a worker shall be returned to an equivalent position within his/her classification.

12.9.3 For any unpaid leave of absence the worker may elect to continue insurance coverage for up to the duration of his/her leave of absence at his/her own expense.

12.9.4 For any paid leave of absence, all benefits continue to accrue.

12.9.5 The Human Resources Director or designee will designate the specific beginning and ending dates to meet the needs of the worker and the City, which shall not be less than four weeks nor exceed one unpaid year.

12.9.6 At the conclusion of a leave of absence for any disability the worker may be required to submit a physician's statement certifying that he/she is medically qualified to resume work.

12.9.7 Use of unpaid leave is subject to the advanced approval of the Department Director or designee and Human Resources. Any and all unpaid leave granted pursuant to this Article shall be granted at time or times as will not reduce the number of employees below that which is reasonably necessary for the efficient conduct of the public business of such department, division or work group. Leaves shall not be unreasonably denied.

12.9.8 All provisions of this Article shall be administered in conformance with all Federal and State Laws.

12.10 Educational Leave and Tuition Reimbursement

12.10.1 The City shall contribute Eleven Thousand Two Hundred Dollars (\$11,200.00) annually on July 1st of each year to an educational leave and tuition reimbursement fund. The City will reimburse expenses for tuition, books, lab fees and equipment, and curriculum fees incurred by a worker, to a maximum of One Thousand Dollars (\$1,000.00) per fiscal year, for classes completed in accredited institutions of learning or approved specialized training groups leading to an academic degree or improved job related skills. Parking fees or non-mandatory health fees related to enrollment will not be included. Programs must be approved in advance. Reimbursement will be provided upon successful completion of approved courses. Employees must attach a final grade of "C" or better for both undergraduate and graduate work. The employee may not elect to take a "pass/fail" grade if the letter system of grading is offered. Courses providing a "pass/fail" must achieve a "pass" to qualify for reimbursement. Funds expended on tuition reimbursement will be subject to appropriate IRS regulations.

12.10.2 Workers wishing to engage in educational programs involving work time may be granted rescheduled time if departmental operations permit.

12.10.3 All workers assigned by the City to attend meetings, workshops, or conventions shall have their dues and reasonable expenses paid by the City and shall be allowed to attend such workshops, meeting and conventions on paid City time. Such required educational functions shall be reimbursed from departmental training funds and shall not be counted against the worker's allowance or the annual tuition reimbursement.

Workers may under the tuition reimbursement fund request reimbursement for trade publications, technical books, and printed materials related to the worker's employment.

12.10.4 In the event that there are unused funds remaining in the city-wide educational leave and tuition reimbursement fund on June 30 of any year, workers who present appropriate receipts verifying expenditures in excess of One Thousand Dollars (\$1,000.00), for items which are reimbursable under this Section 12.12, shall receive a pro rata share of those remaining funds not to exceed the actual amount of the difference between the actual expenditure and One Thousand Dollars (\$1,000.00) up to a maximum of Four Thousand Dollars (\$4,000.00). These requests for additional reimbursement must be received by the City no later than July 15 of that year.

ARTICLE 13: BENEFIT PROGRAMS

13.1 Medical

13.1.1 The City shall continue the existing flexible benefits plan through the term of this Agreement.

13.1.2 The City shall continue to make a non-elective employer contribution to the flexible benefits plan on behalf of each active employee in an amount which, together with the minimum PEMHCA contribution in 13.1.1 equals the following:

\$2,351 per month - family coverage

\$1,811 per month - two-person coverage

\$961 per month - single coverage

[EXAMPLE: If the PEMHCA minimum contribution is \$140, then the City shall make a flexible benefits plan contribution of \$2,211 per month for family coverage, \$1,671 per month for two-person coverage and \$821 per month for single coverage.]

Cash-in-Lieu of Medical Coverage: Employees who waive coverage will be entitled to \$367.00 per month. Effective January 1, 2018, this amount is no longer contributed through the flexible benefits plan.

13.1.3 For the plan year beginning January 1, 2022, the City shall make a nonelective employer contribution to the flexible benefits plan on behalf of each active employee in an amount which, together with the minimum PEMHCA contribution in 13.1.1 equals the contributions in Section 13.1.4 increased by an amount equal to the twelve-month increase in the consumer price index (CPI-U San Francisco-Oakland-San Jose) measured from February 2020 to February 2021. However, the increase in the City's contribution shall be no less than two percent (2.0%) and no more than four percent (4%) (i.e., CPI 2-4%).

13.1.4 For the plan year beginning January 1, 2023, the City shall make a nonelective employer contribution to the flexible benefits plan on behalf of each active employee in an amount which, together with the minimum PEMHCA contribution in 13.1.1 equals the contributions in Section 13.1.4 increased by an amount equal to the twelve-month increase in the consumer price index (CPI-U San Francisco-Oakland-San Jose) measured from February 2021 to February 2022. However, the increase in the City's contribution

shall be no less than two percent (2.0%) and no more than four percent (4%) (i.e., CPI 2-4%).

~~The City shall make a direct contribution equal to the minimum employer contribution for agencies participating in the Public Employees Medical and Hospital Care Act (PEMHCA) on behalf of each active employee and qualified retiree.~~

~~13.1.3 The City shall continue to make a non-elective employer contribution to the flexible benefits plan on behalf of each active employee in an amount which, together with the minimum PEMHCA contribution in 13.1.2 equals the following:~~

~~————— \$2,184 per month ————— family coverage  
————— \$1,659 per month ————— two person coverage  
————— \$833 per month ————— single coverage~~

~~[EXAMPLE: If the PEMHCA minimum contribution is \$122, then the City shall make a flexible benefits plan contribution of \$2,062 per month for family coverage, \$1,537 per month for two person coverage and \$711 per month for single coverage.]~~

~~————— Cash in Lieu of Medical Coverage: Employees who waive coverage will be entitled to \$367.00 per month. Effective January 1, 2018, this amount will no longer be contributed through the flexible benefits plan.~~

~~13.1.4 Effective the latter of January 1, 2019 or ratification of this agreement by the membership, the City shall make a non-elective employer contribution to the flexible benefits plan on behalf of each active employee in an amount which, together with the minimum PEMHCA contribution in 13.1.2 equals the following:~~

~~————— \$2,234 per month ————— family coverage  
————— \$1,709 per month ————— two person coverage  
————— \$883 per month ————— single coverage~~

~~————— Cash in Lieu of Medical Coverage: Employees who waive coverage will be entitled to \$367.00 per month.~~

13.1.5 For the year beginning January 1, 2020 the City shall make a non-elective employer contribution to the flexible benefits plan on behalf of each active employee in an amount which, together with the minimum PEMHCA contribution in 13.1.2 equals the following:

\$2,284 per month family coverage  
\$1,759 per month two-person coverage  
\$933 per month single coverage

Cash-in-Lieu of Medical Coverage: Employees who waive coverage will be entitled to \$367 per month.

- 13.1.6 For calendar year 2016 and calendar 2017, the City will contribute an additional \$41.67 each month towards each bargaining unit member's cafeteria plan. For example, for calendar year 2016, the monthly City contribution for members on the family plan will be \$2189.67 (2148+41.67). This provision will sunset on December 31, 2017.
- 13.1.7 Consistent with applicable laws and regulations, each employee may use his/her allocated amount for any benefits permitted by law and provided for in the flexible benefit plan document. The plan document will be amended to eliminate cash distributions, and to add employee-paid "buy up" of vision benefits. If possible the City will also add an employee-paid short term disability plan such as AFLAC.
- 13.1.8 Workers hired into the unit prior to May 4, 2010, who have at least ten (10) continuous years of permanent service with the City and who retire under PERS shall be reimbursed by the City at the rate of one hundred dollars (\$100.00) per month (in addition to the minimum employer contribution contained in 13.1.2) toward the retiree's worker only health care premium once the employee has exhausted the sick leave conversion to retiree health credits under Section 12.1.4.3.
- In order to be eligible for the reimbursement in this Section, the worker must be enrolled in an available PEMHCA health insurance plan.
- 13.1.9 The City will continue to pay flexible compensation in the amount of Thirty-One Dollars (\$31.00) per month and cash in lieu of medical benefits of Five Hundred Forty-Four Dollars and Seventy-Seven Cents (\$544.77) to those workers hired prior to July 1, 1983 who qualify pursuant to the current programs. Workers hired on July 1, 1983, and thereafter, shall not be entitled to these options. Workers who discontinue flexible compensation or cash in lieu of medical coverage after June 30, 1983, shall not be entitled to re-enroll in these programs.
- 13.1.10 For part-time workers who are a member of the unit, the City shall prorate the dollar amount allocated under Sections 13.1.3, 13.1.4, and 13.1.7.
- 13.1.11 Workers whose medical insurance premium costs exceed the combined allocation available through the cafeteria plan and Section

13.1.2 shall have the excess cost of their medical premiums paid with before-tax compensation through a premium conversion plan.

13.1.12 Each full-time worker must enroll in an available health insurance plan or demonstrate that he/she has health insurance coverage in order to waive coverage under Section 13.1.4.

13.1.12 Workers who wish to have domestic partners covered under the cafeteria plan may do so after filing the “Declaration of Domestic Partnership” form with the California Secretary of State and complying with any other requirements necessary to qualify for domestic partner health benefits under the PEMHCA plans. It is understood that the premiums and benefits provided as a result of covering domestic partners may be taxable, and that the City will administer the program in accordance with State and Federal Tax regulations.

13.1.13 The parties share an interest in addressing the increase in the cost of PEMHCA benefits. The City shall meet and confer with the Union prior to contracting with the alternative provider, consortia or group. However, the Union will have the option to remain in the PEMHCA program.

13.1.14 Effective July 1, 2017, Cash-in-Lieu of Medical Coverage amounts will be included in the calculation of regular rate for overtime purposes. In the event that a court issues a final decision holding that Cash-in-Lieu of Medical Coverage payments do not need to be included in the regular rate, the City will cease including Cash-in-Lieu in the regular rate.

13.1.15 In the event that the City’s contributions towards medical premiums are less than the Kaiser rate at each level of participation (single, two-party, or family) for either plan year 2019 or plan year 2020, the parties will meet and confer in an attempt to address the differences between the City contribution and the Kaiser premium.

## 13.2 Dental Insurance

13.2.1 The City shall pay the full cost for Dental Insurance administered by Delta Dental or an equivalent third party administrator up to the annual maximums described in the summary plan description.

13.2.2 Dental Benefits will be provided as described in the summary plan description.

## 13.3 Vision

- a. Effective the latter of January 1, 2016, or upon agreement with all employee groups, the City shall pay the full cost for fully insured Vision Insurance provided by VSP, or an equivalent insurance provider, providing vision benefits as described in the summary plan description.

13.4 Employee Assistance Program

The City shall continue to provide an employee assistance program to workers as currently provided.

13.5 Life Insurance

The City will provide to all workers life insurance at the rate of 1-1/2 times each worker's regular yearly wage.

ARTICLE 14: RETIREMENT

14.1 The City will continue the retirement program and benefits currently provided under contract with the Public Employees' Retirement System.

14.2 Retirement benefits for employees hired by the City prior to February 12, 2012 shall be those established by the Public Employees' Retirement System (CalPERS) for local miscellaneous members 2.7% at age 55 formula, single highest year.

14.3 Retirement benefits for employees hired by the City on or after February 12, 2012, who are not new members as defined by CalPERS, shall be those established by the Public Employees' Retirement System (CalPERS) for local miscellaneous members 2.0% at age 60 formula, highest three years.

14.4 For new employees, as defined by CalPERS, hired on or after January 1, 2013, retirement benefits shall be those established by the California Public Employees' Retirement System (CalPERS) for Miscellaneous Members 2.0% at age 62 formula, highest three years.

14.5 The full unit member's contribution shall be deducted from the unit member's pay by the City and forwarded to the Public Employees' Retirement System in accordance with the rules and regulations governing such contributions.

14.6 Should the employer rate rise above 14.597%, the increase shall be shared equally between the employee and the employer. As an example, if the employer rate for 2011-12 is 15.597%, the City shall pay 15.097% and the employee shall pay 8.500% (inclusive of the 8.000% fixed employee contribution).

14.7 Effective as soon as practicable and after December 1, 2014, the employee contribution towards the employer's contribution to the Public Employees' Retirement System (CalPERS) shall be taken as a pre-tax deduction from the employees' paycheck each payroll period. The City and the Union agree that the employee contribution towards the employer's contribution will continue past the expiration of the MOU. If for any reason the City is precluded from making this



deduction or the deduction cannot be made on a pre-tax basis, the parties agree to meet and confer regarding ways to cure the defect.

## ARTICLE 15: GRIEVANCE PROCEDURE

### 15.1 Definitions

- 15.1.1 A grievance is an alleged violation, misinterpretation or misapplication of the provisions of this Memorandum of Understanding, policy and/or procedure manuals affecting the working conditions of the workers covered by this Agreement.
- 15.1.2 A “Disciplinary appeal” is an appeal from a disciplinary action of a Letter of Reprimand or higher, against an employee covered by this Memorandum of Understanding.
- 15.1.3 A “grievant” is any worker adversely affected by an alleged violation of the specific provision of this Memorandum, or the Union.
- 15.1.4 A “day” is any day in which the City Hall of Menlo Park is open for business.
- 15.1.5 The “immediate supervisor” is the lowest level administrator who has been designated to adjust grievances and who has immediate jurisdiction over the grievant.

### 15.2 General Provisions

- 15.2.1 Every effort will be made by the parties to settle grievances at the lowest possible level.
- 15.2.2 All documents dealing with the processing of a grievance shall be filed separately from the personnel files of the participants.15.2.3 No party to a grievance shall take any reprisals against the other party to the grievance because the party participated in an orderly manner in the grievance procedure.
- 15.2.3 Failure of the grievant to adhere to the time deadlines shall mean that the grievance is settled. The grievant and the City may extend any time deadline by mutual agreement.
- 15.2.4 Every effort will be made to schedule meetings for the processing of grievances at times which will not interfere with the regular work day of the participants.
- 15.2.5 Either the City or the Grievant may be represented at any step of the grievance procedure by an individual of the party’s choice.

- 15.2.6 Any unit member may at any time present grievances to the City and have such grievances adjusted without the intervention of the Union, as long as the adjustment is reached prior to arbitration and is not inconsistent with the terms of this Memorandum; provided that the City shall not agree to a resolution of the grievance until the Union has received a copy of the grievance and the proposed resolution and has been given the opportunity to file a response. Upon request of the grievant, the grievant may be represented at any stage of the grievance procedure by a representative of the Union.
- 15.2.7 Failure of a unit member to file a grievance over an adverse action which constitutes a “grievance” as defined herein shall not constitute a waiver of other unit members’ rights to file future grievances involving the same or similar adverse actions.
- 15.2.8 The City and Union may agree to consolidate grievances at Level III and beyond.
- 15.2.9 All written responses by Management regarding a grievance shall be sent to the grievant, designated union steward, and the Union.

15.3 Grievance Procedure (for grievances as defined in 15.1.1)

Grievances will be processed in accordance with the following procedures.

15.3.1 Level I - Informal Resolution/Immediate Supervisor

15.3.1.1 Any unit member who believes he/she has a grievance shall present the grievance orally to the immediate supervisor within ten (10) days after the grievant knew, or reasonably should have known, of the circumstances which form the basis for the grievance. Failure to do so will render the grievance null and void. The immediate supervisor shall hold discussions and attempt to resolve the matter within ten (10) days after the presentation of the grievance. It is the intent of this informal meeting that at least one (1) personal conference be held between the aggrieved unit member and the immediate supervisor.

15.3.2 Level II - Department Director

15.3.2.1 If the grievance is not resolved at Level I and the grievant wishes to press the matter, the grievant shall present the grievance in writing on the appropriate form to Department Director within ten (10) days after the oral decision of the immediate supervisor. The written information shall include:

- a) a description of the specific grounds of the grievance including names, dates, and places necessary for a complete understanding of the grievance;
- b) a listing of the provisions of this Memorandum which are alleged to have been violated;
- c) a listing of the reasons why the immediate supervisor's proposed resolution of the problem is unacceptable; and
- d) a listing of specific actions requested by the grievant of the City which will remedy the grievance.

15.3.2.2 The Department Director or designee shall communicate the decision to the grievant in writing within ten (10) days after receipt of the grievance. If the Department Director or designee does not respond within the time limits, the grievant may appeal to the next level.

15.3.2.3 With the concurrence of the City, a worker or the Union may choose to file the formal grievance initially at Level II (the Department Director) instead of Level I.

15.3.2.4 Within the above time limits either party may request a personal conference.

### 15.3.3 Level III - Appeal to City Manager

15.3.3.1 If the grievant is not satisfied with the decision at Level II, the grievant may, within ten (10) days of the receipt of the decision at Level III, appeal the decision to the City Manager. The statement shall include a copy of the original grievance, all decisions rendered and a clear and concise statement of the reasons for the appeal.

15.3.3.2 The City Manager or designee shall respond to the grievance in writing within ten (10) days of receipt of the written appeal.

### 15.3.4 Level IV - Arbitration

15.3.4.1 If the grievant is not satisfied with the decision at Level IV, the grievant may within five (5) days of the receipt of the decision submit a request in writing to the Union for arbitration of the dispute. Within fifteen (15) days of the grievant's receipt of the decision at Level III, the Union shall inform the City of its intent as to whether or not the grievance will be arbitrated. The Union and the City shall attempt to agree upon an arbitrator. If no agreement can be reached, they shall request that the State

Mediation and Conciliation Service supply a panel of five (5) names of persons experienced in hearing grievances involving City employees and who are members of the National Academy of Arbitrators (NAA). Each party shall alternately strike a name until only one (1) name remains. The remaining panel member shall be the arbitrator. The order of striking shall be determined by lot.

- 15.3.4.2 If either the City or the Union so requests, a separate arbitrator shall be selected to hear the merits of any issue raised regarding the arbitrability of a grievance. No hearing on the merits of the grievance will be conducted until the issue of arbitrability has been decided. The process to be used in selecting an arbitrator shall be as set forth in 15.3.5.1.
- 15.3.4.3 The arbitrator shall, as soon as possible, hear evidence and render a decision on the issue or issues submitted to him. If the parties cannot agree upon a submission agreement, the arbitrator shall determine the issues by referring to the written grievance and the answers thereto at each step.
- 15.3.4.4 The City and the Union agree that the jurisdiction and authority of the arbitrator so selected and the opinions the arbitrator expresses will be confined exclusively to the interpretation of the express provision or provisions of this Memorandum at issue between the parties. The arbitrator shall have no authority to add to, subtract from, alter, amend, or modify any provisions of this Memorandum or impose any limitations or obligations not specifically provided for under the terms of this Memorandum. The arbitrator shall be without power or authority to make any decision that requires the City or the administration to do an act prohibited by law.
- 15.3.4.5 After a hearing and after both parties have had an opportunity to make written arguments, the arbitrator shall submit in writing to all parties his/her findings and award.
- 15.3.4.6 The arbitrator shall make a final and binding determination.
- 15.3.4.7 The fees and expenses of the arbitrator shall be shared equally by the City and the Union (including the cost of any list of arbitrators requested pursuant to Section 15.3.4.1). All other expenses shall be borne by the party incurring them, and neither party shall be responsible for the expense of witnesses called by the other. Either party may request a certified court reporter to record the entire arbitration hearing. The cost of the services of such court reporter shall be paid by the party requesting the reporter or shared by the parties if they both mutually agree. If

the arbitrator requests a court reporter, then the costs shall be shared by both parties.

#### 15.4 Disciplinary Appeals

- 15.4.1 A “disciplinary appeal” is a formal written appeal of a Notice of Disciplinary Action (post-Skelly) of any punitive disciplinary action including dismissal, demotion, suspension, reduction in salary, letters of reprimand, or transfer for purposes of punishment. However, letters of reprimand are not subject to the arbitration provisions of this procedure. This procedure also shall not apply to the rejection or termination of at will employees, including those in probationary status. Any reduction in pay for change of assignments which occurs in the course of regular rotation and is not punitive shall not be subject to this procedure.
- 15.4.2 Persons on probationary status (entry-level or promotional) may not appeal under this agreement rejection on probation. Letters of Reprimand may be appealed under this section only to the City Manager level (Section 15.4.4).
- 15.4.3 Any appeal to any punitive disciplinary action (as defined in Section 15.1.2) shall be presented in writing to the City Manager within ten (10) days after receipt of the Notice of Disciplinary Action. Failure to do so will be deemed a waiver of any appeal. The City Manager or designee shall hold a meeting to hear the appeal within ten (10) days after the presentation of the appeal and shall issue a decision on the appeal within ten (10) days of the presentation of the appeal. For letters of reprimand, the City Manager’s decision shall be final. However the employee may write a response and have that response included in his or her personnel file.
- 15.4.4 For appeals from dismissal, demotion, suspension, or reduction in salary, if the employee is not satisfied with the decision of the City Manager, the employee may, within ten (10) days of the receipt of the decision, submit a request in writing to the Union for arbitration of the dispute. Within twenty (20) days of the City Manager’s decision, the Union shall inform the City of its intent as to whether or not the disciplinary matter will be arbitrated. The Union must be the party taking the matter to arbitration.
- 15.4.5 The parties shall attempt to agree to the selection of an arbitrator and may agree to strike names from a list provided by an outside agency such as the State Mediation and Conciliation Service. However, in the event that the City and the Union cannot agree upon the selection of an arbitrator within forty-five (45) days from the date that Union has notified the City of its intent to proceed to Arbitration, either party may request the Superior Court of the County of San Mateo appoint an arbitrator who shall be a retired judge of the Superior Court of San Mateo County.

- 15.4.6 The City and the Union agree that the arbitrator shall prepare a written decision containing findings of fact, determinations of issues and a disposition either affirming, modifying or overruling the disciplinary action being appealed. The parties expressly agree that the arbitrator may only order as remedies those personnel actions which the City may lawfully impose.
- 15.4.7 The fees and expenses of the arbitrator (including the cost of any list of arbitrators) shall be shared equally by the City and Union. All other expenses shall be borne by the party incurring them, and neither party shall be responsible for the expense of witnesses called by the other. Either party may request a certified court reporter to record the entire arbitration hearing. By mutual agreement, the cost of the services of such court reporter shall be shared equally by the parties. However, each party shall be responsible for the cost of transcripts that they order.
- 15.4.8 Nothing herein constitutes a waiver of City or employee rights otherwise granted by law.

## ARTICLE 16: EFFECT ON EXISTING PRACTICES

### 16.1 Changes in Personnel Rules and Department Regulations

During the term of this Memorandum of Understanding, the parties hereto will meet and confer regarding changes proposed by the City in the City's Personnel Rules and Department Rules and Regulations.

### 16.2 Effect of Agreement

This Agreement completely supersedes any prior agreements between the parties. It also supersedes any conflicting provision in the City's Personnel Rules.

### 16.3 Existing Practices

Existing practices and/or benefits which are not referenced in this Memorandum and which are subject to the meet and confer process shall continue without change unless modified subject to the meet and confer process.

### 16.4 Waiver Clause

Except as provided in Section 16.3, Existing Practices, the workers waive their right to meet and confer during the term of this Agreement on any matter raised during the meeting and conferring which preceded this Agreement.

## ARTICLE 17: NONDISCRIMINATION

- 17.1 The parties agree that they, and each of them, shall not discriminate against any employee on the basis of race, religion, color, creed, age, marital status, national origin, ancestry, sex, sexual orientation, medical condition or disability. The parties further agree that this Section shall not be subject to the Grievance Procedure provided in this Agreement. However, any individual, including a representative of the Union, may bring forth a complaint of discrimination and/or harassment on behalf of a worker.
- 17.2 The parties agree that they, and each of them, shall not discriminate against any employee because of membership or lack of membership in the Union, or because of any authorized activity on behalf of the Union. The parties further agree that this Section may be subject to the Grievance Procedure provided in this Agreement.

## ARTICLE 18: MANAGEMENT RIGHTS

- 18.1 Except to the extent that the rights are specifically limited by the provisions of this Agreement, the City retains all rights, powers, and authority granted to it or which it has pursuant to any law, including, but not limited to: The right to direct the work force; increase, decrease or re-assign the work force; hire, promote, demote; discharge or discipline for cause; transfer or reclassify employees; assign employees days of work, shifts, overtime and special work requirements, and to determine the necessity, merits, mission and organization of any service or activity of the City or of any City Department, Agency or Unit.
- 18.2 The City has the sole and absolute right to determine the nature and type of, assign, reassign, revoke assignments of or withdraw assignments of, City equipment, including motor vehicles, to or from employees during, after or before hours of duty.
- 18.1.3 The City has the sole and absolute right to determine the methods, means and numbers and kinds of personnel by which City operations are to be conducted, including the right to contract or subcontract bargaining unit work provided that the City will meet and confer in advance on the impact of subcontracting on work load and safety and any other matter within the scope of representation;
- 18.4 The City has the sole and absolute right to determine methods of financing;
- 18.5 The City has the sole and absolute right to determine size and composition of the work force and allocate and assign work by which the City operations are to be conducted;

- 18.6 The City has the sole and absolute right to determine and change the number of locations, relocations and types of operations, processes and materials to be used in carrying out all City functions;
  - 18.7 The City has the sole and absolute right to make all decision relating to merit, necessity or organization of City Service;
  - 18.8 The City has the sole and absolute right to discharge, suspend, demote, reprimand, withhold salary increases and benefits, or otherwise discipline workers in accordance with applicable laws;
  - 18.9 The City has the sole and absolute right to establish employee performance standards including, but not limited to, quality and standards, and to require compliance therewith;
  - 18.10 The City has the sole and absolute right to take necessary actions to carry out its mission in emergencies; and
  - 18.11 The City has the sole and absolute right to exercise complete control and discretion over its organization and the technology of performing its work.
  - 18.12 The City has the sole and absolute right to take any and all steps necessary to discharge the City’s responsibilities to provide for the safety of the public it serves and to provide employees with a safe working environment; provided, however, nothing herein shall preclude the Union from providing input, consulting and/or meeting and conferring with the City as required by law on such safety issues so long as such actions do not prevent the City from discharging these responsibilities.
- 18.2 The exercise of the foregoing powers, rights, authority, duties, and responsibilities by the City, the adoption of policies, rules, regulations and practices in furtherance thereof, and the use of judgment and discretion in connection therewith shall be limited only by the specific and express terms of this Memorandum and then only to the extent such specific and express terms hereof are in conformance with the Constitution and laws of the United States and the Constitution and laws of the State of California.
- 18.3 The exercise by the City through its Council and management representatives of its rights hereunder shall not in any way, directly or indirectly, be subject to any grievance procedure nor subject to meeting and conferring.

ARTICLE 19: CONCERTED ACTIVITIES

- 19.1 As used in this Article 19, “strike or work stoppage” means the concerted failure to report for duty, the willful absence from one’s position, the stoppage of work, or the abstinence in whole or in part from the full, faithful performance of the duties of



employment for the purpose of inducing, influencing or coercing a change in the conditions of compensation, or the rights, privileges or obligations of employment.

- 19.2 It is agreed and understood that there will be no strike, work stoppage, slowdown, or refusal to fully and faithfully perform job functions with responsibilities, or any interference with the operations of the City, or any concerted effort designed to improve its bargaining position which interferes with, impedes, or impairs City operations by the Union or by its officers, agents or members. The Union agrees that neither the Union nor its officers, agents or members will, in any manner whatsoever, honor, assist or participate in any picketing activities, sanctions or any other form of interference with City operations by any other non-unit employees or members of other employee associations or groups.
- 19.3 Furthermore, the Union agrees that the provisions in this Article 19 are enforceable by the City in a Court of law. The City may, upon its own election, initiate such court action as it deems appropriate to enjoin or impose damages on the Union, its officers, agents or members for activities referred to herein.
- 19.4 It is further agreed and understood that neither the Union nor its officers, agents, or members shall engage in any boycott, picketing or any other concerted attempts to discourage, impair or negatively affect the businesses of members of the City Council.
- 19.5 Nothing herein shall be deemed to limit the remedies available to the City in dealing with concerted activities as described hereinabove.

#### ARTICLE 20: SEPARABILITY

If any provision of this Agreement shall be declared void or unenforceable by a court of competent jurisdiction, the remaining provisions of this Agreement shall remain in full force and effect, except that either party to the Agreement may request the other party to meet and confer in regard to amending the Agreement to replace the provisions declared void or unenforceable. However, there will be no obligation on either party to agree on a replacement provision.

#### ARTICLE 21: DISCIPLINARY ACTION

- 21.1 For just cause, the City has the right to discipline, including suspend, demote, or discharge permanent workers for unsatisfactory work or conduct.
- 21.2 Non-probationary workers whose work or conduct is unsatisfactory but not sufficiently deficient to warrant discipline, demotion, or discharge will be given a written notification of unsatisfactory work or conduct and an opportunity to improve. Failure to correct deficiencies and improve to meet standards may result in

discipline, demotion or discharge. Reprimands shall not be subject to the arbitration provisions of Article 15, Disciplinary Appeals.

21.3 A Notice of Intended Discipline (NOID) must be in writing and served on the worker in person or by registered mail prior to the disciplinary action becoming effective. The Chief Steward of the Chapter and the Union shall also be given a copy unless the worker submits a written request to Human Resources that the Notice of Intended Discipline not be forwarded to the Union. The Notice of Intended Discipline must be filed on a timely basis with the Human Resources Department. The Notice of Intended Discipline shall include:

21.3.1 Statement of the nature of the disciplinary action;

21.3.2 Statement of the reasons for the proposed action;

21.3.3 Statement in ordinary and concise language of the act or the omissions upon which the reasons for the proposed disciplinary action are based; and

21.3.4 Copies of any documents or other items of evidence upon which the intended disciplinary action was fully or in part based.

21.3.5 In cases of demotion, discharge, or suspension of workers in permanent status at the time of the discipline, the Notice of Intended Discipline shall include a statement of the worker's right to respond, either orally, at a meeting requested by the worker, or in writing. The opportunity to respond shall be afforded prior to the action becoming effective, but the worker must respond no later than five (5) days after receipt of notice of intended disciplinary action. A conference, if requested, shall be scheduled and held as soon as possible but in no event later than thirty (30) days after receipt of notice of intended disciplinary action.

## ARTICLE 22: TRANSFER

22.1 Definition

22.1.1 For purposes of this Article, a "transfer" shall consist of a change in work location of a worker from one work site to another work site within the City. Such a transfer does not encompass the process of assignment of a specific position and responsibilities within the department or work location. A worker assigned to more than one work site shall be considered as being transferred only when moved from one City-wide program to another program. A transfer may be initiated by a worker ("voluntary") or by the City ("administrative").

22.2 Voluntary Transfers as a Result of Posting and Filling Vacancies

- 22.2.1 A “vacancy” is a new position, an opening arising from a resignation, retirement, or termination, any position to which a worker is not assigned or which is not committed for purposes of leaves, unresolved administrative transfers or layoffs.
- 22.2.2 Notices of vacancies shall be posted for at least five (5) working days on the bulletin board in the City’s administrative offices. Such notices shall be posted as soon as the City determines that a vacancy exists and shall include the position description, location, and other special requirements.
- 22.2.3 The request for transfer will be sent to the Human Resources with a copy to the Department Director. A conference shall be held at the request of the worker or Human Resources in order to discuss the request.
- 22.2.4 For purposes of selection between two or more workers requesting transfer to a vacant position, the City shall consider the training experience, competencies, length of service in the City, past evaluations, and qualifications of each worker.
- 22.2.5 When the City has considered two or more workers requesting a transfer to a vacant position to be relatively equal on the basis of training, experience, competence, past evaluations, and qualifications, the worker with the most City-wide seniority shall be selected for transfer to the vacant position.
- 22.2.6 The City shall notify the worker requesting transfer, in writing, of the City’s acceptance or denial of the request. The City shall provide written reasons for not granting the transfer request upon the request of the worker. Transfer requests shall be acted upon prior to filling positions by promotion or outside applicants.

22.3 Administrative Transfers

- 22.3.1 An administrative transfer may be initiated by the Human Resources Director or his/her designee and shall be based exclusively on the work related special needs of the City and/or welfare of the workers involved and will not be for punitive or capricious reasons.
- 22.3.2 In the event that circumstances require that a worker be transferred on an administrative basis, the worker and the Union shall be informed of the reason(s) in writing prior to such action and shall be afforded an opportunity to meet with the Human Resources Director regarding the proposed transfer.
- 22.3.3 For purposes of selecting which worker shall be administratively transferred in order to meet the needs of the City, the City shall consider the training, experience, competencies, length of service in the City, past evaluations, qualifications, and current classification of each worker considered. All things being relatively equal, the worker with the least City-wide seniority will be transferred.

22.3.4 If total time of service with the City for two (2) or more workers considered equal is the same, then, as between those workers, the transfer will be determined by a lottery.

22.4 Length of Service Defined

22.4.1 For the purpose of this Article, “length of service” means all hours in paid status including holiday, vacation, and paid leave, but does not include any hours compensated for overtime or standby, , unpaid illness, unpaid industrial accident leave, or hours served as temporary or contract employee in classification other than the classification from which the worker is being transferred.

22.4.2 No seniority credit shall be earned during periods of separation from service with the City, including suspension without pay as a result of disciplinary action.

ARTICLE 23: SAFETY

23.1 It is the City’s intention to provide the safest possible equipment and working conditions to the workforce of the City of Menlo Park. Toward that end, the City is committed to making the necessary expenditures to purchase this equipment.

23.2 The Union and the City agree to continue to participate in the City Safety Committee.

ARTICLE 24: CONTRACTING SERVICES

The City shall notify the Union at least sixty days in advance of the effective date of the proposed action to contract services and shall, upon request, meet and confer with the Union regarding the contracting out of any work to an independent contractor which results in the elimination of a filled bargaining unit position, layoff, or permanently reduces the hours worked by a member of the unit. This provision would also apply if a position was frozen and contract services used to fill the position for more than one annual budget cycle. This provision is not intended to expand upon or contract any rights or obligations already granted or imposed by law. This provision does not mean that the Union is agreeing in advance to anything other than to meet and confer.

ARTICLE 25: TERM OF AGREEMENT

This Agreement shall remain in full force and effect up to and including June 30, 2020, and thereafter shall continue in effect year by year unless one of the parties notifies the other in writing no earlier than January 30 of any year, and no later than March 30 of any year, of its request to modify, amend, or terminate the Agreement. If the parties enter into subsequent meeting and conferring regarding a successor agreement, the terms and conditions of this Agreement shall remain in effect until a successor Agreement is reached, or until meeting and conferring is concluded.

The terms of this Agreement shall be effective upon the adoption of this Agreement by the City Council except as otherwise provided by specific sections of this Agreement.

Dated: \_\_\_\_\_

City of Menlo Park

Local 521, SEIU, CTW, CLC

\_\_\_\_\_  
\_\_\_\_\_  
\_\_\_\_\_

\_\_\_\_\_  
\_\_\_\_\_  
\_\_\_\_\_  
\_\_\_\_\_  
\_\_\_\_\_  
\_\_\_\_\_  
\_\_\_\_\_  
\_\_\_\_\_

APPENDIX "A"

CLASSIFICATIONS REPRESENTED BY  
LOCAL 521, SERVICE EMPLOYEES INTERNATIONAL UNION, CTW, CLC

ACCOUNTANT I  
ACCOUNTANT II  
ACCOUNTING ASSISTANT I  
ACCOUNTING ASSISTANT II  
ADMINISTRATIVE ASSISTANT  
ASSISTANT ENGINEER  
ASSISTANT PLANNER  
ASSOCIATE CIVIL ENGINEER  
ASSOCIATE ENGINEER  
ASSOCIATE PLANNER  
ASSOCIATE TRANSPORTATION ENGINEER  
BUILDING CUSTODIAN  
BUILDING INSPECTOR  
CHILD CARE TEACHER I  
CHILD CARE TEACHER II  
CHILD CARE TEACHER'S AID/ENFORCEMENT OFFICER  
COMMUNICATIONS DISPATCHER  
COMMUNICATIONS TRAINING DISPATCHER  
COMMUNITY DEVELOPMENT TECHNICIAN  
COMMUNITY SERVICE OFFICER  
CONSTRUCTION INSPECTOR  
CONTRACTS SPECIALIST  
DEPUTY CITY CLERK  
ENGINEERING TECHNICIAN I  
ENGINEERING TECHNICIAN II  
ENTERPRISE APPLICATIONS SUPPORT SPECIALIST  
EQUIPMENT MECHANIC  
EXECUTIVE ASSISTANT  
FACILITIES MAINTENANCE TECHNICIAN I  
FACILITIES MAINTENANCE TECHNICIAN II  
GYMNASTICS INSTRUCTOR  
INFORMATION TECHNOLOGY SPECIALIST I  
INFORMATION TECHNOLOGY SPECIALIST II  
JUNIOR ENGINEER  
LIBRARIAN I  
LIBRARIAN II  
LIBRARY ASSISTANT I  
LIBRARY ASSISTANT II  
LIBRARY ASSISTANT III  
LIBRARY CLERK  
LIBRARY PAGE

Classifications

Page 2

MAINTENANCE WORKER I  
MAINTENANCE WORKER II  
MANAGEMENT ANALYST I  
OFFICE ASSISTANT  
PARKING ENFORCEMENT OFFICER  
PERMIT TECHNICIAN  
PLAN CHECK ENGINEER  
PLANNING TECHNICIAN  
POLICE RECORDS SPECIALIST  
PROGRAM AIDE/DRIVER  
PROGRAM ASSISTANT  
PROPERTY AND COURT SPECIALIST  
RECREATION AIDE  
RECREATION LEADER  
RED LIGHT PHOTO ENFORCEMENT SPECIALIST  
SENIOR COMMUNICATIONS DISPATCHER  
SENIOR ENGINEERING TECHNICIAN  
SENIOR EQUIPMENT MECHANIC  
SENIOR FACILITIES MAINTENANCE TECHNICIAN  
SENIOR MAINTENANCE WORKER  
SENIOR OFFICE ASSISTANT  
SENIOR PLANNER  
SENIOR POLICE RECORDS SPECIALIST  
SENIOR PROGRAM ASSISTANT  
SENIOR RECREATION LEADER  
SENIOR SUSTAINABILITY SPECIALIST  
SENIOR WATER SYSTEM OPERATOR  
SUSTAINABILITY SPECIALIST  
TRANSPORTATION DEMAND MANAGEMENT COORDINATOR  
WATER QUALITY SPECIALIST  
WATER SYSTEM OPERATOR I  
WATER SYSTEM OPERATOR II

APPENDIX "B - 1"



## APPENDIX "C"

### Menlo Park Labor Management Committee

#### GOAL

The Union and Management have a sincere desire to maintain and improve their progressive, mature and cooperative labor relations/personnel relationship throughout the length of the contract.

#### MEETINGS

In order to facilitate this, the parties agree to meet as necessary to discuss work and personnel/labor relations related issues of interest to either the workers or management. These meetings shall not replace informal grievance meetings nor the responsibilities of the parties to meet and confer pursuant to the law and the agreement. However topics may include preliminary discussions of matters which may later develop into more formal concerns to be dealt with in official forums.

#### PARTICULARS

In attendance will be representatives from the City of Menlo Park, as determined by the issues to be discussed. A Union staff person and three members selected by the union shall represent the workers. Additional department heads, members or consultants may be included as necessary.

Agenda shall be set in advance and mutually agreed to except that there shall be a regular item for either party to confirm or dispel rumors in labor relations/personnel topics since the last meeting.

Additional meetings may be set with mutual agreement.

Minutes shall be taken with each side alternately taking responsibility for taking and reproducing them. Confidential personal issues shall be discussed off the record and summarized in the minutes.

#### CALPERS LABOR MANAGEMENT COMMITTEE

Effective for the term of this agreement, the City and Union agree to the establishment of a Labor Management Committee (LMC) to serve as an advisory committee and to facilitate employee education and involvement in issues regarding CalPERS retirement benefits, including but not limited to, potential future costs increases and the impacts of said cost increases to the financial stability of the City.

The City and the Union shall each select their own representatives and in equal number, with no more than three (3) on each side. Each side is encouraged to propose issues for discussion, and the committee will jointly set priorities. Decision making within this forum will be by consensus. The LMC will set up regular meetings to occur not less than once per quarter and a means for calling additional meetings to handle issues on an ad hoc basis.

The LMC is not authorized to meet and confer or create contractual obligations nor are they to change the MOU to authorize any practice in conflict with existing contracts or rules.

#### STATE DISABILITY INSURANCE LABOR MANAGEMENT COMMITTEE (SDI-LMC)

Effective for the term of this agreement, the City and Union agree to the establishment of a Labor Management Committee to explore the possibility of the City enrolling employees into the California State Disability Insurance program (SDI –LMC). The SDI-LMC shall evaluate the benefits of enrolling employees in CSDI and consider the benefits of different payment structures (e.g., City contributions versus employee contributions) and will make recommendations on these issues.

The City and Union shall each select their own representatives in equal number, with no more than three (3) on each side. The SDI-LMC is not authorized to meet and confer or create contractual obligations nor are they to change the MOU to authorize any practice in conflict with existing contracts or rules.

The City and Union will consider the recommendations of the SDI-LMC and will meet and confer over those recommendations, but neither will be under any obligation with regard to the SDI-LMC's recommendations.

#### SPECIAL LABOR MANAGEMENT SUB-COMMITTEES

Effective for the term of this agreement, the City and Union agree to the use of a special Labor Management Sub-Committee to serve as an advisory committee and to facilitate employee education and involvement regarding the performance appraisal program and the City of Menlo Park Dental and Vision Plan.

The City and the Union shall each select their own representatives and in equal number, with no more than two (2) on each side. The sub-committee will jointly set priorities. Decision making within this forum will be by consensus. The sub-committee will set up regular meetings to occur not less than once per quarter.

The LMC is not authorized to meet and confer or create contractual obligations nor are they to change the MOU to authorize any practice in conflict with existing contracts or rules.

## APPENDIX “D”

# EMPLOYEE RIGHTS AND RESPONSIBILITIES UNDER THE FAMILY AND MEDICAL LEAVE ACT

### Basic Leave Entitlement

FMLA requires covered employers to provide up to 12 weeks of unpaid, job-protected leave to eligible employees for the following reasons:

- for incapacity due to pregnancy, prenatal medical care or child birth;
- to care for the employee’s child after birth, or placement for adoption or foster care;
- to care for the employee’s spouse, son, daughter or parent, who has a serious health condition; or
- for a serious health condition that makes the employee unable to perform the employee’s job.

### Military Family Leave Entitlements

Eligible employees whose spouse, son, daughter or parent is on covered active duty or call to covered active duty status may use their 12-week leave entitlement to address certain qualifying exigencies. Qualifying exigencies may include attending certain military events, arranging for alternative childcare, addressing certain financial and legal arrangements, attending certain counseling sessions, and attending post-deployment reintegration briefings.

FMLA also includes a special leave entitlement that permits eligible employees to take up to 26 weeks of leave to care for a covered servicemember during a single 12-month period. A covered servicemember is: (1) a current member of the Armed Forces, including a member of the National Guard or Reserves, who is undergoing medical treatment, recuperation or therapy, is otherwise in outpatient status, or is otherwise on the temporary disability retired list, for a serious injury or illness\*; or (2) a veteran who was discharged or released under conditions other than dishonorable at any time during the five-year period prior to the first date the eligible employee takes FMLA leave to care for the covered veteran, and who is undergoing medical treatment, recuperation, or therapy for a serious injury or illness.\*

**\*The FMLA definitions of “serious injury or illness” for current servicemembers and veterans are distinct from the FMLA definition of “serious health condition”.**

### Benefits and Protections

During FMLA leave, the employer must maintain the employee’s health coverage under any “group health plan” on the same terms as if the employee had continued to work. Upon return from FMLA leave, most employees must be restored to their original or equivalent positions with equivalent pay, benefits, and other employment terms.

Use of FMLA leave cannot result in the loss of any employment benefit that accrued prior to the start of an employee’s leave.

### Eligibility Requirements

Employees are eligible if they have worked for a covered employer for at least 12 months, have 1,250 hours of service in the previous 12 months\*, and if at least 50 employees are employed by the employer within 75 miles.

**\*Special hours of service eligibility requirements apply to airline flight crew employees.**

### Definition of Serious Health Condition

A serious health condition is an illness, injury, impairment, or physical or mental condition that involves either an overnight stay in a medical care facility, or continuing treatment by a health care provider for a condition that either prevents the employee from performing the functions of the employee’s job, or prevents the qualified family member from participating in school or other daily activities.

Subject to certain conditions, the continuing treatment requirement may be met by a period of incapacity of more than 3 consecutive calendar days combined with at least two visits to a health care provider or one visit and

a regimen of continuing treatment, or incapacity due to pregnancy, or incapacity due to a chronic condition. Other conditions may meet the definition of continuing treatment.

### Use of Leave

An employee does not need to use this leave entitlement in one block. Leave can be taken intermittently or on a reduced leave schedule when medically necessary. Employees must make reasonable efforts to schedule leave for planned medical treatment so as not to unduly disrupt the employer’s operations. Leave due to qualifying exigencies may also be taken on an intermittent basis.

### Substitution of Paid Leave for Unpaid Leave

Employees may choose or employers may require use of accrued paid leave while taking FMLA leave. In order to use paid leave for FMLA leave, employees must comply with the employer’s normal paid leave policies.

### Employee Responsibilities

Employees must provide 30 days advance notice of the need to take FMLA leave when the need is foreseeable. When 30 days notice is not possible, the employee must provide notice as soon as practicable and generally must comply with an employer’s normal call-in procedures.

Employees must provide sufficient information for the employer to determine if the leave may qualify for FMLA protection and the anticipated timing and duration of the leave. Sufficient information may include that the employee is unable to perform job functions, the family member is unable to perform daily activities, the need for hospitalization or continuing treatment by a health care provider, or circumstances supporting the need for military family leave. Employees also must inform the employer if the requested leave is for a reason for which FMLA leave was previously taken or certified. Employees also may be required to provide a certification and periodic recertification supporting the need for leave.

### Employer Responsibilities

Covered employers must inform employees requesting leave whether they are eligible under FMLA. If they are, the notice must specify any additional information required as well as the employees’ rights and responsibilities. If they are not eligible, the employer must provide a reason for the ineligibility.

Covered employers must inform employees if leave will be designated as FMLA-protected and the amount of leave counted against the employee’s leave entitlement. If the employer determines that the leave is not FMLA-protected, the employer must notify the employee.

### Unlawful Acts by Employers

FMLA makes it unlawful for any employer to:

- interfere with, restrain, or deny the exercise of any right provided under FMLA; and
- discharge or discriminate against any person for opposing any practice made unlawful by FMLA or for involvement in any proceeding under or relating to FMLA.

### Enforcement

An employee may file a complaint with the U.S. Department of Labor or may bring a private lawsuit against an employer.

FMLA does not affect any Federal or State law prohibiting discrimination, or supersede any State or local law or collective bargaining agreement which provides greater family or medical leave rights.

**FMLA section 109 (29 U.S.C. § 2619) requires FMLA covered employers to post the text of this notice. Regulation 29 C.F.R. § 825.300(a) may require additional disclosures.**



For additional information:  
1-866-4US-WAGE (1-866-487-9243) TTY: 1-877-889-5627  
[WWW.WAGEHOUR.DOL.GOV](http://WWW.WAGEHOUR.DOL.GOV)

U.S. Department of Labor | Wage and Hour Division



WHD Publication 1420 · Revised February 2013

## APPENDIX “D”

### California Family Rights Act

The *Fair Employment and Housing Act*, enforced by the Department of Fair Employment and Housing (DFEH), contains family care and medical leave provisions for California employees. These leave provisions, known as the *California Family Rights Act* (CFRA), cover employers who do business in California and employ 50 or more part-time or full-time people.

All such employers must provide information about the CFRA provisions to their employees and post this information in a conspicuous place where employees tend to gather. Employers who provide employee handbooks must include information about CFRA leave in the handbook.

#### CFRA Leave Requirements

- To be eligible for CFRA leave, an employee must have more than 12 months of service with the employer and have worked at least 1,250 hours for that employer in the 12-month period before the leave begins.
- An eligible employee may take an **unpaid** leave to bond with an adopted or foster child or to bond with a newborn.
- An eligible CFRA employee may take **unpaid** leave to care for a parent, spouse or child with a serious health condition. CFRA leave may also be taken for the employee's own serious health condition.
- Full-time employees may take leave of up to 12 work weeks in a 12-month period. Part-time employees may take leave on a proportional basis. The leave does not need to be taken in one continuous period of time.
- An employer may require a 30-day advance notice of the need for a CFRA-qualifying leave. When this is not possible due to the unexpected nature of the leave, notice should be given as soon as practicable. Notice can be written or verbal and should include the timing and the anticipated duration of the leave. An employer must respond to a leave request within 10 calendar days.
- The employer may require written communication from the health-care provider of the child, parent, spouse, or employee with a serious health condition stating the reasons for the

leave and the probable duration of the condition.

- Employees are entitled to take CFRA leave in addition to any leave entitlement they might have under PDL. Leave taken for the birth or adoption of a child must be completed within **one year** of the event.
- In addition to the family care and medical leave requirements of the CFRA, employers of five or more persons have additional obligations pertaining to PDL. Please refer to the DFEH publication “Facts on Pregnancy Disability Leave” for more information.

#### Salary and Benefits During CFRA Leave

- Employers are **not** required to pay employees during a CFRA leave. An employer may require an employee to use accrued vacation time or other accumulated paid leave other than sick time. If the CFRA leave is for the employee's own serious health condition, the use of sick time **can be** required.
- If the employer provides health benefits under a group plan, the employer must continue to make these benefits available during the leave. The employee is also entitled to accrual of seniority and participation in other benefit plans.

#### Return Rights After CFRA Leave

- After CFRA leave, employees are guaranteed a return to the same or comparable position and can request the guarantee in writing.
- If the same position is no longer available, such as in a layoff or closure, the employer must offer a position that is comparable in terms of pay, location, job content, and promotional opportunities, unless the employer can prove that no comparable position exists. An employee is not entitled to reinstatement if the employee would have been otherwise laid off or terminated.

#### Family Temporary Disability Insurance (FTDI) or “Paid Family Leave”

Employees on CFRA leave of absence may also be eligible for six weeks of **paid** leave under FTDI, a program administered by the California Employment Development Department (EDD). For further information, contact the EDD at (800) 480-3287 or visit the web site at [www.edd.ca.gov](http://www.edd.ca.gov).

#### Filing a Complaint

If you believe your CFRA rights have been violated, you can explore filing a complaint with DFEH by following these steps:

- Contact DFEH by calling the toll-free number at (800) 884-1684 to schedule an appointment.
- Be prepared to present specific facts about the alleged discrimination or denial of leave.
- Keep records and provide copies of documents that support the charges in the complaint, such as paycheck stubs, calendars, correspondence, and other potential proof of discrimination.

Complaints must be filed within **one year** of the last act of discrimination.

DFEH will conduct an impartial investigation. We are not an advocate for either the person complaining or the person complained against. We represent the State of California. DFEH will, if possible, try to assist both parties to resolve the complaint.

If a voluntary settlement cannot be reached, and there is sufficient evidence to establish a violation of the law, DFEH may issue an accusation and litigate the case before the Fair Employment and Housing Commission or in civil court. If the Commission or a court decides in favor of the complaining party, remedies may include reinstatement, back pay, reasonable attorney's fees, damages for emotional distress, and administrative fines.

For more information, contact DFEH toll free at (800) 884-1684

TTY number at (800) 700-2320  
or visit our web site at [www.dfeh.ca.gov](http://www.dfeh.ca.gov)

*In accordance with the California Government Code and ADA requirements, this publication can be made available in Braille, large print, computer disk, or tape cassette as a disability-related reasonable accommodation for an individual with a disability. To discuss how to receive a copy of this publication in an alternative format, please contact DFEH at the numbers above.*



State of California  
Department of Fair Employment & Housing

DFEH-188 (04/04)

## APPENDIX "E"

### ANNUAL VACATION LEAVE CASHOUT

#### PURPOSE

To establish a streamlined policy and procedure for eligible employees to receive the cash value of Vacation upon "selling" that Vacation time back to the City, otherwise known as the "Cashout" of Vacation accruals.

#### SCOPE

The Vacation "Cashout" program is available to all eligible employees represented by the Service Employees International Union (SEIU).

#### POLICY

Eligibility for participating in "Cashout" shall be determined by the following:

1. Employees must be Fulltime or Part-time with benefits.
2. Employees must have taken at least twenty-four (24) hours of Vacation Leave and/or Compensatory Time in the twelve (12) months immediately preceding the request for "Cashout" to be eligible to "Cashout" up to eighty (80) hours of Vacation. Employees must have taken at least forty (40) hours of Vacation Leave and/or Compensatory Time in the twelve (12) months immediately preceding the request for "Cashout" to be eligible to "Cashout" up to one hundred twenty (120) hours of Vacation.
3. Employee must pre-elect the number of Vacation Leave hours they will "Cashout" during the following calendar year up to maximum of 120 hours, prior to the start of that calendar year. The election will apply only to Vacation Leave hours accrued in the next tax year and eligible for "Cashout".
4. The election to "Cashout" Vacation Leave hours in each designated year will be irrevocable. This means that employees who elect to "Cashout" Vacation Leave hours must cash out the number of accrued hours pre-designated on the election form provided by the City.
5. Employees who do not pre-designate or decline a "Cashout" amount by the annual deadline established by the City will be deemed to have waived the right to "Cashout" any leave in the following tax year and will not be eligible to "Cashout" Vacation Leave hours in the next tax year.

6. Employees who pre-designate “Cashout” amounts may request a “Cashout” at any time in the designated tax year by submitting a “Cashout” Request Form to Payroll. Payroll will complete the “Cashout” upon request, provided the requested “Cashout” amount has accrued and is consistent with the amount the employee pre-designated. If the full amount of hours designated for cash out is not available at the time of “Cashout” request, the maximum available will be paid.
  
7. For employees who have not requested payment of the elected “Cashout” amount by November 1 of each Calendar Year, Payroll will automatically “Cashout” the pre-designated amount in a paycheck issued on or after the payroll date including November 1.

PROCEDURES

<u>Employee:</u>	<ol style="list-style-type: none"> <li>1. <u>Verify eligibility for participation.</u></li> <li>2. <u>Complete the “Cashout” Election Form and submit to Human Resources Division prior to the annual deadline.</u></li> </ol>
<u>Human Resources Division:</u>	<ol style="list-style-type: none"> <li>1. <u>Communicate list of Employee elections to Finance/Payroll Division.</u></li> </ol>
<u>Finance Department/Payroll Division:</u>	<ol style="list-style-type: none"> <li>1. <u>Verify eligibility for “Cashout” when requested by confirming election and available annual accruals.</u></li> <li>2. <u>Process payment for cash value of “Cashout” requests minus withholdings required by State and IRS, to be distributed with regular payroll check in the next available payroll cycle.</u></li> <li>3. <u>Adjust employee records to deduct Vacation Leave time paid off from available accruals.</u></li> </ol>

**RESOLUTION NO. 6648**

**RESOLUTION OF THE CITY COUNCIL OF THE CITY OF MENLO PARK  
APPROVING AND ADOPTING THE COMPREHENSIVE MEMORANDUM OF  
UNDERSTANDING WITH SERVICE EMPLOYEES INTERNATIONAL UNION  
LOCAL 521 WITH A TERM OF JULY 1, 2021 THROUGH JUNE 30, 2023**

WHEREAS, the City of Menlo Park received a report on expiring labor agreements on February 9, 2021 in accordance with City Council’s policy on Public Input and Outreach Regarding Labor Negotiations; and

WHEREAS, the Memorandum of Understanding (“MOU”) between the City of Menlo Park (“City”) and the Service Employees International Union Local 521 (“SEIU”) expired on June 30, 2021; and

WHEREAS, Negotiators for City and SEIU began the meet and confer process on March 26, 2021, and met three times before reaching tentative agreement (TA) on a successor MOU on June 2, 2021; and

WHEREAS, City and the SEIU have met and conferred in good faith and have agreed to the attached comprehensive successor MOU (Exhibit A); and

WHEREAS, the terms of the successor MOU make changes to the wages, flexible benefit plan contributions, and one-time lump sum payments in 2021 and 2022 and has a term July 1, 2021 through June 30, 2023; and

WHEREAS, SEIU membership ratified the TA set forth in Exhibit A on June 15, 2021; and

NOW THEREFORE, THE CITY COUNCIL OF THE CITY OF MENLO PARK HEREBY RESOLVES THAT:

1. City ratifies the TA with SEIU for a successor MOU with a term of July 1, 2021 through June 30, 2023, as set forth in Exhibit A attached and incorporated by reference.
2. City Council authorizes the city manager to execute the successor MOU.
3. City Manager may approve formatting edits to the successor MOU.

I, Judi A. Herren, City Clerk of Menlo Park, do hereby certify that the above and foregoing City Council Resolution was duly and regularly passed and adopted at a meeting by said City Council on the seventeenth day of August, 2021, by the following votes:

//  
  
//  
  
//  
  
//  
  
//

AYES:

NOES:

ABSENT:

ABSTAIN:

IN WITNESS WHEREOF, I have hereunto set my hand and affixed the Official Seal of said City on this seventeenth day of August, 2021.

---

Judi A. Herren, City Clerk





**STAFF REPORT**

**City Council**  
**Meeting Date:** 8/17/2021  
**Staff Report Number:** 21-145-CC

**Regular Business:** **Adopt Resolution No. 6649 to ratify a successor agreement between the City of Menlo Park and the American Federation of State, County, and Municipal Employees Local 829 expiring June 30, 2023**

**Recommendation**

Adopt Resolution No. 6649 to ratify a successor agreement between the City of Menlo Park and the American Federation of State, County and Municipal Employees, Local 829 (AFSCME) expiring June 30, 2023.

UPDATE – This report has been updated from the early release version with several edits indicated in red underlined text. Attachment C provides additional background for the Committee for employee cost share reduction (MOU Section 14.8, Page 40.)

**Policy Issues**

City Council retains sole authority to enter into memoranda of understanding with recognized labor units. Memorandum of understanding (MOU) negotiations are governed by the Meyers-Milias-Brown Act (MMBA), Government Code section 3500. MMBA requires that local agencies meet and confer in good faith regarding wages, hours, and other terms and conditions of employment with representatives of recognized collective bargaining units. MMBA further requires that the City fully consider proposals made by collective bargaining unit representatives before determining policy or course of action.

**Background**

City Council held its initial hearing to receive public input before launching negotiations with AFSCME February 9. After the public input hearing, City Council appointed Charles Sakai of Sloan Sakai Yeung Wong LLP to serve as the City's chief negotiator. Mr. Sakai received direction to negotiate the successor MOU with AFSCME, and both parties reached a tentative agreement (Attachment A) June 18.

The previous MOU for non-sworn supervisors, AFSCME, had original terms of October 1, 2017, through June 30, 2020. The MOU was then extended to expire June 30, 2021, and added the California State Disability Insurance (SDI) benefit and modified the long-term disability program to coordinate with SDI. AFSCME agreed to defer their July 2020 inflation-based across-the-board wage increase at the City's request due to the financial uncertainty resulting from the COVID-19 pandemic. Under that agreement,

classifications and employees represented by AFSCME received the deferred July 2020 inflation-based wage increase of 2.9 percent effective June 20, 2021. The MOU between City and AFSCME expired June 30, 2021, so the wage increase that was deferred to June 20, 2021 was within the extended MOU term. Additionally, City past practice honors the terms and intent of expired MOUs until the full ratification of a successor agreement.

**Analysis**

This report summarizes the tentative agreement negotiated in good faith with AFSCME representatives. AFSCME’s membership ratified the tentative agreement June 21. While the tentative agreement conforms to the authority provided to Mr. Sakai in-closed session, the final action requires City Council ratification at a public meeting. The City Council adopted 2021-22 budget fully funds the tentative agreement provisions.

Attachment A transmits a redline version of the expired MOU to highlight the tentative agreement for City Council ratification. Table 1 summarizes tentative agreement terms with financial impacts.

Table 1: Tentative agreement items with financial impact to City		
Item	Description	Cost/ (savings)
<b>Term</b> MOU Article 24 Page 51	The tentative agreement (TA) provides for a two-year term beginning with City Council ratification and ending June 30, 2023. Given that negotiation of a successor agreement is not required for one fiscal year, the City is estimated to save approximately \$30,000 per year which reflects legal costs and internal staff time required to support negotiations.	(\$30,000)
<b>Pay rates</b> MOU Section 7.1 Page 17	Assuming City Council ratification August 17, 2021, the TA includes an across the board cost of living adjustment to all pay rates in this unit, as follows: <ul style="list-style-type: none"> <li>3% effective the pay period following July 1, 2022</li> </ul>	\$146,400
<b>Lump sum payments</b> MOU Section 7.1.2 Page 17	The TA provides a lump sum payment to all employees in this unit as follows: <ul style="list-style-type: none"> <li>\$2,000 per employee effective the pay period following ratification in 2021</li> <li>\$2,000 per employee effective the pay period following July 1, 2022</li> </ul>	75,441 <u>75,441</u> \$150,882
<b>Flexible benefits plan contribution</b> MOU Section 13.1.2 Page 36	The TA includes an across the board increase in flexible benefits plan contribution based on the annual Consumer Price Index for the San Francisco Bay Area: <ul style="list-style-type: none"> <li>2022 CPI* Increase between 2-4%</li> <li>2023 CPI Increase between 2-4%</li> </ul>	20,808 <u>21,227</u> \$42,035
<b>Total</b>	Year 1 Year 2, incremental Contract term, compounded	\$96,249 \$213,068 \$330,125

\*Consumer price index

Classification and compensation study (MOU Section 7.1.3, Page 17)

The City last completed a classification and compensation study for non-sworn personnel in 2015-16. The 2015-16 study's results informed salary increases for those positions and job families found to be below market median total compensation. Total compensation incorporates the full range of wages and benefits, including pension costs and pension cost-share. The tentative agreement requires the City to retain a survey consultant, similar to the 2015-16 total compensation study. Unlike the 2015-16 study, Section 7.1.3 does not result in salary increases for positions identified as below market. The provision intends to inform negotiations of a successor agreement effective July 1, 2023, alongside the City's financial recovery, including assessed values for the 2021 and 2022 property tax rolls and the status of transient occupancy tax (TOT) revenue.

City staff will request proposals from qualified consultants in the first half of 2022 to meet the deadline of October 31, 2022, for the survey results. The cost is unknown.

Committee for employee cost share reduction (MOU Section 14.8, Page 40)

Menlo Park led the pension reform effort during the Great Recession of the mid-'00s by implementing a cost-share provision the AFSCME MOU (Section 14) beginning July 1, 2011. The cost-share provision requires that employees fully pay their employee cost (~~6.5 percent~~, 7.0 percent, ~~7.3 percent~~ or 8.0 percent, depending on their date of hire) plus 50 percent of the employer's variable cost over 15.850 percent. Active AFSCME employees contribute 5.53 percent in 2021-22 per the terms of Section 14.

The Public Employees' Pension Reform Act (PEPRA) of 2012 structurally modified pension benefits available to new members in the CalPERS system. Effective January 1, 2013, all new members to CalPERS (PEPRA members) are subject to the following reduction in benefit compared to employees grandfathered under the legislation:

1. A required 50/50 cost-share of the total cost retirement benefit (normal cost) earned by the employee in a given year. The PEPRA employee contribution, ~~7.3~~ ~~6.5~~ percent for 2021-22, is above the City's cost-share, and adjusts annually to reflect changes in CalPERS' normal cost assumptions;
2. Full retirement age of 62 and early retirement starting at age 52 with an early retirement penalty;
3. A cap on pensionable wages that adjusts annually, 2021 cap is \$153,671; and
4. Exemption of certain wages and benefits previously included in the pension benefit calculation.

The tentative agreement establishes a venue for management and labor representatives to discuss the complex issue of rising pension costs and the current pension landscape .

**Impact on City Resources**

The City Council adopted budget incorporates the terms of the tentative agreement. The net increase in City costs is \$330,125 over the life of the contract.

**Environmental Review**

This action is not a project within the meaning of the California Environmental Quality Act (CEQA) Guidelines §§ 15378 and 15061(b)(3) as it will not result in any direct or indirect physical change in the environment.

## Public Notice

Public notification was achieved by posting the report 15 days prior to the City Council meeting of August 17, 2021.

## Attachments

- A. Redlined version – MOU between AFSCME and City of Menlo Park, July 1, 2021 – June 30, 2023
- B. Resolution No. 6649
- C. [Memo: Pension cost-share background and factors; July 9, 2021](#)

Report prepared by:

Barbara Tong, Management Analyst I

Kristen Middleton, Interim Human Resources Manager

Nick Pegueros, Assistant City Manager

**MEMORANDUM OF UNDERSTANDING**  
**BETWEEN**  
**AMERICAN FEDERATION OF**  
**STATE, COUNTY, AND MUNICIPAL EMPLOYEES**  
**LOCAL 829**  
**AND**  
**THE CITY OF MENLO PARK**



~~October 1, 2017 through June 30, 2020~~ July 1, 2021 – June 30, 2023

TABLE OF CONTENTS

	Page
PREAMBLE.....	4
ARTICLE 1: RECOGNITION.....	4
ARTICLE 2: UNION SECURITY.....	5
ARTICLE 3: REPRESENTATION.....	8
ARTICLE 4: DEFINITIONS.....	9
ARTICLE 5: LAYOFF AND RE-EMPLOYMENT.....	9
ARTICLE 6: PERSONNEL ACTIONS.....	12
6.1: Probation.....	12
6.2: Performance Evaluation.....	14
6.3: Performance Improvement Plan.....	14
6.4: Personnel Files.....	14
6.5: Promotional Opportunities.....	15
6.6: Reclassification.....	16
6.7: Recruitment.....	17
6.8: Re-employment – Voluntary Separation.....	17
ARTICLE 7: PAY RATES AND PRACTICES.....	17
7.1: Overall Wage Adjustments.....	17
7.2: Step Increases.....	18
7.3: Application of Rates.....	18
7.4: Effect of Promotion, Demotion or Transfer on Salaries.....	19
7.5: Bilingual Differential.....	19
7.6: Call Back Pay.....	19
7.7: Standby Pay.....	20
7.8: Rest Period Following Extended Work.....	20
7.9 Working Out of Classification.....	21
7.10: Night and Weekend Differential.....	21
7.11: Court Appearances.....	21
7.12: <u>Lump Sum Payments</u>	
7.13: <u>Classification and Compensation Study</u>	
ARTICLE 8: HOURS AND OVERTIME.....	22
ARTICLE 9: UNIFORMS.....	24
ARTICLE 10: HOLIDAYS.....	25
ARTICLE 11: VACATIONS.....	27
ARTICLE 12: LEAVE PROVISIONS.....	28
12.1: Sick Leave.....	28
12.2: Long Term Disability.....	31
12.3: Leave Without Pay.....	31
12.4: Jury Duty and Subpoenas.....	32
12.5: Military Leave.....	32
12.6: Bereavement Leave.....	33
12.7: Maternity and Parental Leave.....	33
12.8: Miscellaneous Leave Provisions.....	33
12.9: Educational Leave and Tuition Reimbursement.....	34
ARTICLE 13: BENEFIT PROGRAMS.....	35
ARTICLE 14: RETIREMENT.....	37
ARTICLE 15: GRIEVANCE PROCEDURE.....	38
ARTICLE 16: EFFECT ON EXISTING PRACTICES.....	44

ARTICLE 17: NONDISCRIMINATION.....	44
ARTICLE 18: MANAGEMENT RIGHTS.....	44
ARTICLE 19: CONCERTED ACTIVITIES.....	45
ARTICLE 20: SEPARABILITY.....	46
ARTICLE 21: DISCIPLINARY ACTION.....	46
ARTICLE 22: TRANSFER.....	47
ARTICLE 23: SAFETY.....	49
ARTICLE 24: TERM OF AGREEMENT.....	49
APPENDIX A: CLASSIFICATIONS	
APPENDIX B: PAY RANGES	
APPENDIX C: LABOR MANAGEMENT COMMITTEE	

## PREAMBLE

This Memorandum of Understanding is entered into by and between American Federation of State, County and Municipal Employees, AFL-CIO (hereinafter "Union") and the City of Menlo Park (hereinafter "City"). This Memorandum of Understanding is entered into pursuant to the Meyers-Miliias-Brown Act (Government Code Sections 3500-3510) and has been jointly prepared by the parties.

## ARTICLE 1: RECOGNITION

- 1.1 The Union is recognized as the exclusive representative of the classifications for City employees as listed in Appendix "A" to this Agreement. Nothing herein shall be construed to discriminate against any individual who chooses to exercise his/her right of self-representation under Section 3502 of the Government Code.
  
- 1.2 Each newly established job classification shall be assigned to an appropriate representation unit by the Human Resources Director, after consultation with recognized employee organizations, if they find that there is an appropriate unit to which such job classifications may be assigned. An employee organization may appeal in writing from such assignment to the Human Resources Director within thirty (30) calendar days of said determination. If the Union is unsatisfied with the results of said appeal, the Union may invoke impasse procedures in accordance with Government Code 3500. In general the City shall adhere to objectives which require that the appropriate unit shall be the broadest feasible grouping of positions that share an identifiable community of interests. Factors to be considered may include:
  - a. Similarity of the general kinds of work performed, types of qualifications required and the general working conditions.
  - b. History of representation in the City and similar employment.
  - c. Consistency with the organizational patterns of the City of Menlo Park.
  - d. Number of employees and classifications, and the effect on the administration of employer-employee relations created by the fragmentation of classifications and proliferation of units.
  - e. Effect on the classification structure and impact on the stability of employer-employee relationship of dividing single or related classifications among two or more units.



- 1.3 The following employees are not eligible for representation by this bargaining unit:
- 1.3.1 All sworn police and sworn police management classifications which are contained in other bargaining units;
  - 1.3.2 Members of the Management Team who are not subject to merit system employment procedures or protection;
  - 1.3.3 Independent contractors.

## ARTICLE 2: UNION SECURITY

### 2.1 Agency Shop

Consistent with the provisions of the California Government Code, Section 3502.5, an employee covered by this agreement shall either: (1) become a member of the Union and pay regular Union dues, or (2) pay to the Union an agency (representation) fee as permitted by law, or (3) present to the Union and the City's Human Resources Director a written declaration that he or she is a member of a bona fide religion, body, or sect that has historically held conscientious objections to joining or financially supporting public employee organizations. An employee who qualifies for this exemption shall, in lieu of the agency fee payment, pay an amount equal to the agency fee to one of the following three (3) non-religious, non-labor, charitable organizations:

- Second Harvest Food Bank of Santa Clara and San Mateo Counties
- Boys & Girls Clubs of the Peninsula
- InnVision Shelter Network

An employee who claims such exemption must submit written proof of such charitable payment annually to the Union and the Human Resources Director. If the employee fails to provide such written proof, the employee will be required to pay the agency fee.

### 2.2 Fee Deduction

If any employee in a classification covered by this MOU fails to authorize one of the above deductions within thirty (30) calendar days of date of hire or within thirty (30) calendar days' notice of the provisions of this agency shop, the City shall deduct the agency fee from the employee's paycheck. The City shall determine the timing of such automatic deductions. The requirement that employees who are not members of the Union pay this representation agency fee shall remain in effect until the earlier of: (1) expiration of this Agreement; (2) termination of the Agency Shop clause by action of the bargaining unit; or (3) legislation invalidating the manner in which Agency Shop was adopted. In the event that employees in the representation unit vote to rescind Agency Shop, the provisions of Section 2.3 – Maintenance of Membership, shall apply to dues-paying members of the Union.

### 2.3 Maintenance of Membership

Any employee who becomes a member of AFSCME shall not revoke such authorization except during the thirty (30) calendar day period between ninety (90) calendar days and sixty (60) calendar days preceding the expiration of this Memorandum of Understanding.

Revocation during said period shall be by written, signed statement furnished to the City with a copy sent to the Union (by the City).

An employee who so withdraws from Union membership shall still be subject to the provisions of Agency Shop (Section 2.1 above).

An employee who is subsequently employed in a position outside of the AFSCME unit shall not be required to continue dues deduction.

## 2.4 Payroll Deduction

2.4.1 The Union may have the regular dues of its members within the representation unit deducted from employees' paychecks under procedures prescribed by the City for such deductions. Dues deductions shall be made only upon signed authorization from the employee upon a form furnished by AFSCME and distributed by the City, and shall continue until: (1) such authorization is revoked, in writing, by the employee pursuant to the provisions of this Section 2.4; or (2) the transfer of the employee out of the representation unit.

2.4.2 The Union shall notify the City at least thirty (30) days in advance of any change in its dues and fees.

2.4.3 Employees may authorize dues deductions only for the organization certified as the recognized employee organization of the unit to which the employees are assigned.

2.4.4 Employees may voluntarily elect to have contributions deducted from their paychecks under procedures prescribed by the District for the P.E.O.P.L.E. fund. Such deductions shall be made only upon signed authorization from the employee and shall continue until such authorization is revoked in writing.

2.4.5 If, after all other involuntary and insurance premium deductions are made in any pay period, the balance is not sufficient to pay the deduction of Union dues, agency fee, or charity fee required by this Section, no such deduction shall be made for the current pay period.

2.4.6 The provisions of Section 2.4.1 above shall not apply during periods that an employee is separated from the representation unit, but shall be reinstated upon the return of the employee to the representation unit. For the purpose of this section, the term separation includes transfer out of the representation unit, layoff, and leave of absence without pay.

## 2.5 Union Obligations

2.5.1 The Union shall provide the City with a copy of the Union's Hudson Procedure for the determination and protest of its agency fees. The Union shall provide a copy of said Hudson Procedure to every agency fee payor covered by this Memorandum of Understanding and annually thereafter, and as a condition to any percentage change in the agency fee.

2.5.2 The Union will supply the City with deduction authorization forms and/or membership applications as well as other informational materials it wishes to be distributed to new employees.

2.5.3 Annually, the Union shall provide the City with copies of the financial report which the Union annually files with the California Public Employee Relations Board, the United States Department of Labor (Form LM-2), or the Union's balance and operating statement for the prior year. Failure to file such a report within sixty (60) days after the end of its fiscal year shall result in the termination of all agency fee deductions without jeopardy to any employee, until such report is filed.

2.5.4 The Union shall refund to the City any amount paid to it in error upon presentation of supporting evidence.

## 2.6 City Obligations

2.6.1 Any new employees hired into positions covered by this Memorandum of Understanding shall be provided by the City and shall execute an "Employee Authorization for Payroll Deduction" form selecting one of the following: (1) Union dues; (2) agency fee; or (3) if he/she qualifies pursuant to the requirements of Section 2.1 above, a fee equal to agency fee payable to one of three (3) negotiated charities.

2.6.2 P.E.O.P.L.E. Checkoff. All employees who choose to do so may request an additional deduction from their paychecks to be forwarded to the Union and accounted for in a separate notation. Such additional deduction shall be used for political campaign purposes and shall be totally voluntary.

2.6.3 All transmittal checks shall be accompanied by documentation which denotes the employee's name, employee ID number, amount of deduction and member or fee payor status.

2.6.4 The City shall hand out agreed upon Union materials along with Agency Shop forms.

2.7 Hold Harmless

The Union shall indemnify, defend, and hold the City harmless against any and all claims, demands, suits, orders, or judgments, or other forms of liability that arise out of or by reason of this Union Security section, or any action taken or not taken by the City under this Section 2. This includes, but is not limited to, the City Attorney's fees and costs.

2.8 Upon request from the Union, but not more than once every six (6) months, the City shall supply the Union with a list of the names, addresses, and classifications of all unit employees except those who file written notice with the Human Resources Department objecting to release of addresses, in which case information will be transmitted without address. Once a month, the City shall supply the Union with a list of representation unit new hires and separations which occurred during the previous month. Additionally, once a month the City shall supply to the Union a list, generated by the City, that includes all represented employees, their Department, division and an indication of their membership status.

2.9 Except in cases of emergency, the Union shall be informed sufficiently in advance in writing by Management before any proposed changes not covered by this Memorandum of Understanding are made in benefits, working conditions, or other terms and conditions of employment which require the meet and confer or meet and consult process.

ARTICLE 3: REPRESENTATION

3.1 It is agreed that, as long as there is no disruption of work, three (3) Union representatives shall be allowed reasonable release time away from their work duties, without loss of pay, to act in representing a unit employee or employees on grievances or matters requiring representation before the City or similar agencies. The Union shall designate the three (3) representatives under this section. Only one (1) representative shall be entitled to release time under this section for any one (1) grievance or group of related grievances. Release time shall be granted for the following types of activities:

3.1.1 A meeting of the representative and an employee or employees in the unit related to a grievance.

3.1.2 A meeting with Management.

3.2 The Union agrees that the representative shall give advance notification to his/her supervisor before leaving the work location except in those cases involving emergencies where advance notice cannot be given. Release time is subject to the legitimate scheduling needs of the department.

3.3 Three (3) Union representatives who are City employees shall be allowed a reasonable amount of time off without loss of pay for formal negotiation purposes. Preparation

time for negotiations shall not be on release time without approval of the Human Resources Director.

- 3.4 Three (3) representatives shall be allocated up to two (2) hours time off every other month without loss of pay for purposes of meeting and consulting on matters within the scope of representation, other than formal negotiations.

#### ARTICLE 4: DEFINITIONS

##### 4.1 Definitions

- 4.1.1 A “temporary” or “contract” employee is an employee employed for a definite term of up to six months, although such temporary employee may be held over for up to three (3) additional months when the temporary employee is filling a vacancy created by leave without pay and the leave is extended beyond the initial fixed period.
- 4.1.2 A “provisional” employee is an employee employed for a definite term of more than six (6) months, although such provisional employee may be held over beyond the initial term of employment as specified in Section 12.4.1. A provisional employee shall be employed and treated in all respects for the entire term of employment as a provisional employee, the same as a probationary employee.
- 4.1.3 A “probationary” employee is an employee who has not yet completed the probationary period, or any extension(s) thereof, as provided in this Agreement. A probationary employee is eligible for benefits provided in this Agreement, except as limited by Sections 6.1.5 and 6.1.8 of this Agreement.
- 4.1.4 A “permanent” employee is an employee who has satisfactorily completed the probationary period, or any extension(s) thereof. A permanent employee is eligible for benefits provided in this Agreement.

#### ARTICLE 5: LAYOFF AND RE-EMPLOYMENT

##### 5.1 Layoff

- 5.1.1 Whenever in the judgment of the City Council it becomes necessary in the interests of economy or because the position no longer exists, the City Council may abolish any position or employment in the competitive service, or may reduce the hours of any position. The decision to abolish a position or reduce the hours of any position shall not be subject to the grievance procedure contained in this Agreement.
- 5.1.2 It is agreed between the parties that attrition is the preferred method of accomplishing any necessary reduction in the work force.

- 5.1.3 If a permanent reduction of hours is proposed for a particular classified position, the incumbent has the right to exercise any and all of the rights set forth in this Article. The incumbent may also choose to be laid off and receive the benefits contained in this Article.
  
- 5.2 Notification of Layoff
  - 5.2.1 Employees being laid off shall be given written notice from the City's Human Resources Department at least forty-five (45) calendar days prior to the effective dates of layoff. The layoff notice shall contain a statement of the effective date of layoff, a statement of "bumping rights" including the specific positions into which the employee may bump, and a statement of re-employment rights. Notice of layoff shall be given by personal service and the employee shall sign an acknowledgment of personal service; or by certified mail, return receipt, postage prepaid. The Union shall receive concurrent notice of individual layoff notices.
  - 5.2.2 The Union shall be afforded an opportunity to meet with the City to discuss the circumstances requiring the layoff and any proposed alternatives.
  
- 5.3 Seniority
  - 5.3.1 For the limited purposes of this Article 5, "length of service" means all hours in paid status including holiday, vacation, and paid leave, but does not include any hours compensated for overtime or standby, military leave, unpaid illness, unpaid industrial accident leave, or hours served as a temporary or contract employee in classifications other than the classification in which the employee is being laid off.
  - 5.3.2 In the event an employee reverts to a previously held classification, seniority shall include all time accrued previously in the lower classification, as well as all time accrued in the higher classification.
  - 5.3.3 No seniority credit shall be earned during periods of separation from service with the City, including suspension without pay as a result of disciplinary action.
  
- 5.4 Order of Layoff
  - 5.4.1 All temporary employees in a particular classification will be laid off before any provisional, probationary or permanent employee in the classification.
  - 5.4.2 All provisional employees in a particular classification will be laid off before any probationary or permanent employee in the classification.
  - 5.4.3 All probationary employees in a particular classification will be laid off before any permanent employee in the classification.
  
- 5.5 Layoff Procedures

Except as otherwise provided, layoffs will be made in reverse order of seniority. The employees with the least time served in a classification shall be laid off first, with ensuing layoffs occurring in reverse order of length of service in the classification. If two employees have served the same time in the classification, then as between those two employees, the layoff will be based on total time of service with the City. If total time of service with the City is the same, then, as between those two employees, the layoff will be determined by a lottery.

## 5.6 Bumping Rights

- 5.6.1 A permanent employee who is designated for layoff, including an employee on probation following reclassification, transfer, or promotion from a permanent position, may elect, in lieu of layoff, to be reassigned to a position in a lateral or lower related classification within his/her department, or another department, provided that in order to displace the employee with less service the laid off employee must have held permanent status in the classification into which he/she is bumping.
- 5.6.2 When a senior employee chooses to bump into a position in a lateral or lower, related classification, said employee must accept the salary, hours, and working conditions of the position to which return is requested.
- 5.6.3 A bargaining unit employee requesting to bump into a classification as provided herein, must make such request to the Human Resources Director in writing within seven (7) calendar days of his/her receipt of written notice of layoff. Failure to comply with the deadline provided herein shall be deemed a waiver of the bumping rights provided in this Section 5.6.
- 5.6.4 Nothing herein shall preclude bumping between bargaining units.

## 5.7 Re-employment

- 5.7.1 The names of employees laid off shall be placed on a re-employment list in inverse order of seniority for a period of two (2) years from the date of layoff. The employee with the greatest seniority on the re-employment list shall be offered reinstatement when a vacancy occurs in a classification in which the employee held permanent status.
- 5.7.2 A laid off employee may refuse an offer of re-employment to a position for which he/she is qualified, however, refusal of two (2) offers of re-employment to the classification from which laid off shall automatically cause removal of the employee's name from the re-employment list and loss of any re-employment rights.
- 5.7.3 Any employee who accepts an offer of re-employment shall have his/her name removed from the re-employment list.

- 5.7.4 An employee who has been laid off and has been placed on a re-employment list shall be eligible, during the time the employee is on the re-employment list, to take promotional exams.
- 5.7.5 Offers of re-employment shall be made via the U.S. Mail Service, Certified Return Receipt, and shall include the specific position and/or hours being offered, the rate of pay, level of benefits, a current job description, a mechanism for acceptance or refusal of the offer of re-employment within the prescribed time limit, and a place for the laid off employee's signature. Failure to respond within ten (10) days from the date of service of offer of re-employment shall be deemed a refusal of that offer of re-employment.

The Union shall receive concurrent notice of each re-employment offer. Date of service is defined as the date marked on the certified mail return card, or the date the notice is returned by the postal service as undeliverable.

## 5.8 Miscellaneous Provisions

- 5.8.1 For the limited purpose of Article 5, permanent employees, including employees on probation following reclassification, re-employment, reinstatement, transfer, promotion, or demotion from a permanent position who are laid off shall be entitled to one (1) month severance pay and three (3) months of paid health insurance.
- 5.8.2 Employees appointed from a re-employment eligibility list shall have all rights accrued at the time of layoff restored including accrued sick leave, rate of vacation accrual and seniority, but excluding benefits to the extent compensation has been received prior to re-employment. Severance pay, if any, shall not be repaid.

## ARTICLE 6: PERSONNEL ACTIONS

### 6.1 Probation

- 6.1.1 The probationary period shall be regarded as part of the testing process and shall be utilized for closely observing the employee's work, for securing the most effective adjustment of a new employee to a prospective position, and for rejecting any probationary employee whose performance is not satisfactory.
- 6.1.2 During the seventh pay period following employment, the employee shall receive a performance evaluation. Human Resources shall send a reminder notice of this deadline to the appropriate supervisor, with copies to the employee and City Manager.



6.1.3 All original and promotional appointments shall be subject to a probationary period of six (6) months for unit members. The Human Resources Director may, based upon the recommendation of the employee's supervisor, extend the probationary period not to exceed six (6) months if the employee marginally performed the necessary job functions and needs an additional six (6) months to bring performance to a satisfactory level. Total absences lasting four (4) weeks or more shall extend the review period by the corresponding duration of the absence.

6.1.4 At least one month prior to permanent appointment the City shall begin to review the work of the probationary employee to determine the following:

- a. certify him/her for the position;  
or
- b. extend the probation;  
or
- c. reject him/her for the position.

The City shall take action on this determination by the last day of the probation period by notifying the employee in writing. If the notification is delayed by more than five working days following the last day of probation, the employee shall become permanent.

6.1.5 If the service of a probationary employee is unsatisfactory, the employee will be notified in writing that he/she has been rejected for the permanent position. Said notice shall contain the reasons for rejection. The Human Resources Director shall, upon request, afford an interview in a timely fashion to the terminated employee for discussion of the reasons for termination. The employee may, upon request, be accompanied by a Union representative. The interview shall not be deemed a hearing nor shall it obligate the City to reconsider or alter the termination action.

6.1.6 An employee deemed unsatisfactory for a position shall return to his/her prior classification and non-probationary status in that classification and to the pay step he/she would have had if not promoted, transferred or voluntarily demoted.

6.1.7 Departments may not shift job assignments as a reason in itself for placing an employee on probationary status.

6.1.8 The parties agree that probationary employees shall have the same rights as other employees under this Memorandum of Understanding, including full and complete access to the grievance procedure, except that employees who do not hold prior permanent status with the City shall have no right to review any disciplinary action or decision to unfavorably terminate the probation.

Employees who do hold prior permanent status shall have the right to appeal any disciplinary action, but not the decision to unfavorably terminate the probation.

6.1.9 A probationary period begins on the first day of work when the employee is selected to fill a permanent position.

## 6.2 Performance Evaluation

6.2.1 The City may, from time to time, develop reasonable guidelines that enable the supervisor to adequately evaluate the employee as to satisfactory job performance. Job performance reviews shall be conducted pursuant to regularly established and announced policies. The guidelines shall be in accordance with the job specifications for the position being reviewed.

6.2.2 During the term of this MOU, the Union and the City agree to meet and confer over the creation of a pay-for-performance system.

6.2.3 Performance evaluations are not appealable through the grievance procedure but, in the event of disagreement over content, the employee may request a review of the evaluation with the next higher level of Management, in consultation with the Human Resources Director. For purposes of this review, the employee may be represented by the Union. Decisions regarding evaluation appeal shall be made in writing within ten (10) working days following the meeting.

## 6.3 Performance Improvement Plans

When the performance of an employee falls below the minimum standards established for a position, a performance improvement plan may be developed. The employee has the right to have a Union representative present during the development of the performance improvement plan. Performance improvement plans must describe in detail the areas of deficiency, and contain a reasonable plan for improvement.

When used, Performance Improvement Plans shall be an integral extension of the job performance review process, and shall not be used, by themselves, for disciplinary actions.

## 6.4 Personnel Files

6.4.1 The Human Resources Department shall maintain personnel records for each employee in the service of the City showing the name, title of position held, the department to which assigned, salary, changes in employment status, attendance records and such other information as may be considered pertinent. An employee is entitled to review his/her personnel file upon written request or may authorize, in writing, review by his/her Union representatives, with the exception of information obtained confidentially in response to reference inquiries. Upon written request by the employee, an employee or the Union shall be allowed copies of materials in an employee's personnel file relating to a grievance.

6.4.2 The City shall notify an employee and an authorized representative of the Union of any adverse material placed in an employee's personnel file if that material is or has not previously been reviewed with the employee. The employee shall have a reasonable time and opportunity to comment thereon.

6.4.3 In any disciplinary action the City may not rely upon any previous written warnings, notice of suspension or demotion, or written evaluation not contained in said file as justification for any personnel action which adversely affects the employee in question, but may rely on oral warnings not made a part of the file and issued within the preceding six (6) months. In the event an employee who has received written warnings or reprimands has completed twenty-four (24) months of work without further disciplinary action, his/her prior disciplinary record of similar instances, except for sustained findings of violations of the City's Anti-Harassment and Non-Discrimination policy, shall no longer be relied upon in any determination which in any manner affects his/her employment status and shall be removed from the employee's personnel file upon request from the employee. In cases where an employee is suspended or demoted and such discipline is sustained, a record of such action shall be kept in the personnel file and any such documentation supporting such action shall be kept in a separate file in the Human Resources Department.

6.4.4 Personnel files of individual employees are confidential information and shall be used or exhibited only for administrative purposes or in connection with official proceedings before the City Council. The City will only release information to creditors or other persons upon proper identification of the inquirer and acceptable reasons for the inquiry. Information then given from personnel files is limited to verification of employment, length of employment and verification and disclosure of salary range information. Release of more specific information may be authorized in writing.

## 6.5 Promotional Opportunities

6.5.1 Promotional opportunities for classifications within the representation unit will be posted for at least ten (10) working days (Monday through Friday) prior to closing applications. Such postings shall include a description of the type of examination and screening process that will be used in filling the position. Any test given shall relate to the skills, knowledge, and abilities necessary to perform the job. Where an interview panel is used as part of the examination process, at least one member of that panel shall, whenever feasible, be a person who is not employed by the City, but is employed by a different municipality performing or supervising similar duties and responsibilities..

6.5.2 Members of the bargaining unit who are permanent employees applying for promotional opportunities and who meet the minimum qualifications for the position will be considered and interviewed.

- 6.5.3 In the event a temporary employee is appointed to the position being temporarily occupied for 2,080 hours or more, the total hours worked prior to the date of appointment shall be totaled and divided by the permanent hours per week, and the seniority adjusted to reflect the time served as a temporary employee. The adjusted seniority will be recognized for purposes of seniority, vacation, and salary advancements.

## 6.6 Reclassification

- 6.6.1 During the term of this Agreement, the City shall notify the employee concerned in case of contemplated change in job content as contained in the classification descriptions which were in effect at the beginning of the Agreement. The Union shall be notified in advance of any contemplated changes in classification descriptions and such changes shall be discussed with the Union, provided that the City shall have the final decision regarding job content. The Union shall be given a reasonable opportunity to meet and confer on the impact of any such changes on matters within the scope of representation.
- 6.6.2 Once each year, during the month of January, an employee may request in writing a re-evaluation of his/her job based on significant changes in job content or significant discrepancies between job content and the classification description. The request must contain justification. A statement by Management that a job re-evaluation request will be submitted with the departmental budget does not relieve an employee from the responsibility of submitting his/her own request in a timely manner. If meetings are held, the employee may request representation by the Union. The City will process the request and issue a recommendation within ninety (90) days. The City shall not agree to a change in the appropriate pay level for a job description until the Union has received a copy of the proposed change and has been given the opportunity to meet and confer with the City. Reclassifications shall become effective the first pay period of the fiscal year.

If the employee receives a favorable recommendation for reclassification prior to the first pay period of the fiscal year, he or she will receive pay for working out of classification under Section 7.8.

During the term of this Agreement, the Union shall coordinate submission of job re-evaluation requests.
- 6.6.3 In conducting classification studies, the compensation figure calculated for each City shall consist of the following components: base salary, employer paid employee contributions to the retirement system, and deferred compensation contributions made by the employer on behalf of the employee.
- 6.6.4 The reclassification procedure shall not be used for the purpose of avoiding use of the promotion or demotion procedures.

6.7 Recruitment

In cases where an employee has vacated an authorized position within the unit, the City shall endeavor to begin the recruitment process within thirty (30) working days.

6.8 Re-employment – Voluntary Separation

Any employee who voluntarily terminates employment and is rehired within twelve months of the date of separation from the City shall have their accrual rates adjusted to the levels achieved prior to separation, except that the time in which the employee was not employed by the City shall not be counted. In addition, all leave balances not paid out upon separation shall be restored to the levels appearing on City records as of the date of separation, except for floating holiday which will not be restored for the remainder of the calendar year in which the separation occurred.

For all other purposes, the time in which the employee was not employed by the City will be treated in the same manner as an unpaid leave of absence.

Re-employment of any employee within the twelve (12) month period is at the sole discretion of the City. If the City decides not to re-employ the former employee, the decision of the City shall be final and not be subject to appeal or to the grievance procedure.

ARTICLE 7: PAY RATES AND PRACTICES

7.1 Overall wage adjustment

7.1.1 ~~Effective the beginning of the first full pay period following the later of July 1, 2022 or City Council adoption, the pay rates for employees in this representation unit shall be increased by an amount equal to three percent (3%). Effective the beginning of the first full pay period after ratification of this Agreement by the membership and approval by City Council, the pay rates for employees in this representation unit shall be increased by four Percent (4.0%). The pay rates for employees in the representation unit shall be as set forth in Appendix “B” to this Agreement.~~

7.1.2 Lump Sum Payments  
Year 1  
Year 1 Payment - AFSCME members who are City employees during the first pay period following the later of City Council adoption of the resolution authorizing amendments to the MOU or July 1, 2021 will receive a one-time lump sum payment of \$2,000. Employees may elect to have the \$2,000 Lump Sum Payment deposited into their Deferred Compensation Account (subject to IRS maximum contribution limits). If the employee does not elect to deposit the Lump Sum Payment into their Deferred Compensation Account or if the money cannot be lawfully deposited, it will be included in the employee’s paycheck for the

applicable pay period. The Parties intend and understand that this lump sum payment is non-pensionable and will not be reported to CalPERS. The parties also agree that this payment is intended to be specific to the pay period in which it is paid and is to be considered part of the regular rate for this pay period only.

#### Year 2

Year 2 Payment – AFSCME members who are City employees during the first pay period following the later of City Council adoption of the resolution authorizing amendments to the MOU or July 1, 2022 will receive a one-time lump sum payment of \$2,000. Employees may elect to have the \$2,000 Lump Sum Payment deposited into their Deferred Compensation Account (subject to IRS maximum contribution limits). If the employee does not elect to deposit the Lump Sum Payment into their Deferred Compensation Account or if the money cannot be lawfully deposited, it will be included in the employee’s paycheck for the applicable pay period. The Parties intend and understand that this lump sum payment is non-pensionable and will not be reported to CalPERS. The parties also agree that this payment is intended to be specific to the pay period in which it is paid and is to be considered part of the regular rate for this pay period only.

#### 7.1.3 Classification and Compensation Study

The parties agree to meet with the City’s retained survey consultant, and review the consultant’s recommended survey jurisdictions, benchmark classifications, and survey matches for a revised Total Compensation Survey to be completed by October 31, 2022. The union will have a minimum of two (2) AFSCME members representatives attending each meeting on release time. Meetings shall begin no later than September 1, 2022 and shall continue on a monthly basis, subject to any agreement to modify the schedule.

The Parties intend the Total Compensation Survey to provide information to support consideration of market-based equity adjustments for individual classifications for successor MOU negotiations. Negotiations will consider both the total compensation survey results and the City’s Financial recovery, including:

- Impact on assessed values for the 2021 and 2022 rolls
- TOT recovery, considering 2019 baseline.

~~Effective the beginning of the first full pay period following July 1, 2018, the pay rates for employees in this representation unit shall be increased by three percent (3.0%). The pay rates for employees in the representation unit shall be as set forth in Appendix “B” to this Agreement.~~

~~7.1.3 Effective the beginning of the first full pay period following July 1, 2019, the pay rates for employees in this representation unit shall be increased by two and one half percent (2.5%). The pay rates for employees in the representation unit shall be as set forth in Appendix “B” to this Agreement.~~

## 7.2 Step Increases

Merit advances from the first salary step to the second salary step shall be granted at six (6) month intervals and between second and subsequent steps at one (1) year intervals if the affected employee has demonstrated continued competent service. Employees who are hired in at Steps B, C or D, or are promoted and placed at Steps B, C or D will be eligible for their next step increase in six (6) months. For the purpose of determining step time requirements, time will commence on the first day of the month coinciding with or following entrance onto a salary step. Step increases shall be effective on the first day of the payroll period in which the time requirements have been met.

During the term of this Agreement, the parties agree to discuss, in an informal manner, alternatives to the merit pay system and related step increases, which may include exploration of various pay for performance systems, as well as ways in which to recognize certificates, advanced degrees and other career achievements. Such discussions may lead to an alternative pay system that would be implemented in lieu of the current system detailed in Sections 7.2 and 7.3 of this Memorandum of Understanding. If both parties agree to such a system during the term of this agreement, the change shall be documented by side letter with the intent of including it in subsequent contracts. Nothing in this section shall commit either party to making a change to the current system during the contract term.

## 7.3 Application of Rates

7.3.1 Employees occupying a position in the competitive service shall be paid a salary or wage within the range established for that position's class under the pay plan as provided. The minimum rate for the class shall normally apply to beginning employees. However, subject to the approval of the Human Resources Director, the department head may hire beginning employees who are especially qualified by their training or by their previous experience at any step in the range.

7.3.2 In the event that a newly hired employee is placed above Step A on the salary schedule due to recruitment problems, as opposed to the conditions in 7.3.1 above, incumbents in that classification who have been placed on a lower step of the salary schedule will be moved to the same step on the salary schedule as the newly hired employee, and all such employees will be allowed to move to the next step in six months.

## 7.4 Effect of Promotion, Demotion or Transfer on Salaries

### 7.4.1 Promotion

Upon promotion, the employee shall be placed on the first step in the new salary range, or on the step which provides for a minimum five percent (5%) increase in salary, whichever is greater, not to exceed the top step of the new range.

7.4.2 Demotion

Upon demotion of an employee with permanent status in his/her current class, his/her salary shall be adjusted to the highest step in the new class not exceeding the salary received in the former class.

7.4.3 Transfer

Upon transfer, the salary shall remain unchanged.

7.5 Bilingual Differential

7.5.1 Employees who are assigned to job duties requiring bilingual skills are eligible to receive Sixty-Five Dollars (\$65.00) each pay period for the use of bilingual skills in job duties arising during the normal course of work.

7.5.2 Eligibility for the bilingual pay differential shall be determined by the Human Resources Director on the basis of a proficiency test determined by the City.

7.5.3 Bilingual skills shall not be a condition of employment except for employees who are hired specifically with that requirement. If an employee is hired under this provision, that requirement shall be included in the initial appointment letter.

7.5.4 The City retains the right to discontinue the bilingual differential for any individual employee when bilingual services are no longer required, provided the City gives the Union ten (10) days notice prior to such revocation, in order to allow the opportunity for the parties to meet and consult.

7.5.5 No employee shall be required to use bilingual skills who is not compensated under this section.

7.6 Call Back Pay

7.6.1 Any employee who is required by the City to report to their normal work location on a day when the employee has not been scheduled, or any employee called back to work after completing their regular work day and leaving their normal work location, shall be entitled to a minimum of two (2) hours of compensation at one and one-half times their hourly rate of pay.



- 7.6.2 Employees who do not return to their normal work location, but who are required to work remotely, are not eligible for call back pay, but shall be paid for time actually worked.
- 7.6.3 Payment for call back may be at the cash rate specified in Section 7.6.1 above or in compensatory time off at the rate of one and one-half hours for each hour worked, at the employee's option. Prior to the end of the pay period, the employee shall designate, on the appropriate City form, his/her choice of either compensation at one and one-half times their hourly rate of pay or compensatory time off.

## 7.7 Standby Pay

- 7.7.1 An employee performing standby duty outside the employee's regular work shift shall be compensated at the rate of Three Dollars and Seventy-Five Cents (\$3.75) per hour for each hour the employee is assigned to standby duty. In the event the SEIU employees' standby rate changes, the City will maintain a fifty cent (\$0.50) differential in the standby hourly rate. An employee shall not combine standby pay with call back pay or overtime.

## 7.8 Rest Period Following Extended Work

- 7.8.1 A Public Works employee shall be entitled to eight (8) hours of rest period when they work more than sixteen (16) hours within a twenty-four (24) hour period beginning with the time the worker reports to work.
- 7.8.2 Prior to working over sixteen (16) hours within a twenty-four (24) hour period and triggering the eight (8) hour rest period the employee must get approval from the Public Works Director or his/her designee.
- 7.8.3 Rest periods are unpaid unless the rest period overlaps the employee's regular work shift in whole or in part. The employee will be paid for that portion of the rest period that overlaps the employee's normal working shift. The employee will be required to work the remainder of their normal working shift that does not overlap with the eight (8) hour rest period unless they request and are approved for leave. The employee will not be paid for the time between expiration of the rest period and his/her normal work shift.
- 7.8.4 This section shall not apply in emergency situations.

## 7.9 Working Out of Classification

- 7.9.1 The term "working out of classification" is defined as a Management authorized assignment to perform work on a temporary basis wherein

significant duties are performed by an employee holding a classification within a lower compensation range. The appropriate Department Director or Designee must approve assignments of Working out of Classification in writing and on a City-authorized form.

The employee must be working in a budgeted position (i.e., the position must be vacant or the incumbent must be on a long term leave of absence and/or vacation). Pay for working out of classification shall be as follows:

7.9.1.1 An employee performing duties associated with a higher position on an out of classification basis will receive acting pay of five percent (5%) for the hours worked in that capacity.

When the Department Head anticipates that the out of classification assignment will be for a period of 240 hours or more, the employee will receive the pay rate of the higher classification beginning with the start of the assignment. If such a determination has not been made by the end of the 240 cumulative hours worked in the higher classification, the employee shall receive the pay rate of the higher classification.

7.9.2 Out of classification provisions do not apply to work assignments performed in connection with declared conditions of public peril and/or disaster.

#### 7.10 Night and Weekend Differential

7.10.1 Employees in the Library assigned to work hours between 5:00 P.M. and 8:00 A.M. weekdays or between Friday from 5:00 P.M. to Monday 8:00 A.M. shall be compensated for night and weekend differential at five percent (5%) above the employee's base pay.

7.10.2 The Communications and Records Manager assigned swing, midnight, relief or day shift on the weekend shall be compensated for night and weekend differential at five percent (5%) above the employee's base pay. Overtime hours shall not be used to qualify for weekend or night shift differential.

#### 7.11 Court Appearances

Employees required to appear in Court during off-duty hours to testify regarding matters arising out of the employee's employment with the City, shall receive a minimum of four (4) hours pay at time and one-half (1.5). The City reserves the right to require the employee to wait to testify at their work location and perform duties as assigned while waiting to testify, provided the Court consents. If the Court requirement expires prior to the expiration of the four (4) hour minimum, the employee shall be released.

This section does not apply in situations where the employee is held over after or called in prior to his or her regular shift as long as the period is adjacent to the normal work shift. In these situations, standard overtime provisions shall apply.

## ARTICLE 8: HOURS AND OVERTIME

### 8.1 Hours of Work

#### 8.1.1 Regular Work Schedules

- a. The regular work schedule for all employees except those on a flexible schedule such as a 4/10, 9/80 or 12 hour schedule, shall consist of forty (40) hours within a seven (7) day work week and is five (5) consecutive days served in units of eight (8) hours. For this schedule, the workweek begins Sunday midnight and ends Saturday at 11:59 P.M.
- b. A 4/10 work schedule shall be four (4) days served in units of ten (10) hours within a seven (7) day work week. For this schedule, the workweek begins Sunday midnight and ends Saturday at 11:59 P.M.
- c. A 9/80 work schedule shall be nine (9) days served in one (1) unit of eight (8) hours and eight (8) units of nine (9) hours over a two week pay period. For this schedule, the workweek shall begin exactly four (4) hours after the start time of the day of the week which is each employee's regular alternate day off.

8.1.2 Part-time Employees. Employees who work less than the regular week and day as set forth above shall be designated as part-time and shall have hours scheduled by the appropriate supervisor and approved by the City's Human Resources Director.

8.1.3 Lunch Periods. All employees working a work shift of six (6) hours or more, shall observe an unpaid lunch period of not less than thirty (30) minutes nor more than sixty (60) minutes. Lunch periods shall be scheduled with the approval of the department head.

8.1.4 Rest Periods. One (1) fifteen (15) minute rest break with pay shall be provided to unit members for each four (4) hours of service. Rest periods and lunch periods may not be aggregated and used to extend the lunch period or shorten the work day as part of a regular schedule.

### 8.2 Overtime

#### 8.2.1 Definition.

- a. Overtime for employees is defined as any time worked in excess of forty (40) paid hours in any seven day work week.

Overtime shall be compensated pursuant to Section 8.2.3. All overtime must be authorized and approved in advance by the Department Head.

8.2.2 Modified Schedules. At the request of either the employee or Department Head, the Department Head may approve a schedule of more than eight (8) hours per day without overtime compensation. Employees shall not be assigned irregular hours to avoid overtime.-Such a work schedule must be consistent with the regular work schedules defined in Section 8.1.1.

8.2.3 Overtime. Overtime may be assigned on a required basis or requested by the employee and approved by the Department Head. Overtime shall be compensated at either (1) the rate of one and one-half (1.5) times the employee's regular rate of pay or (2) in the form of compensatory time at the rate of one and one-half (1.5) hours for each hour worked, as described in Section 8.2.4.

8.2.4 Compensatory Time. An employee may accumulate a maximum of one hundred sixty (160) hours of compensatory time. Compensatory time may be used when the services of an employee are not needed for the efficient functioning of his/her department, and must be approved in advance by the Department Head. Once an employee has reached the limits of compensatory time in this section he/she shall receive cash at the overtime rate for all overtime worked.

Upon termination, all unused compensatory time shall be paid out at the employee's existing rate of pay.

- a. Employees will make an irrevocable election to receive either CTO or pay for all overtime hours worked in the following calendar year. This election will occur once annually, coinciding with the vacation cash-out election period.

- 1) If an employee fails to file his or her election by the annual deadline established by the City, that employee will receive pay for all overtime hours worked in the following calendar year and no compensatory time may be accrued.
- 2) Overtime offered as "pay only" (e.g., when the worker's choice of CTO would interfere with a department's ability to recover the cost of the overtime) can only be worked for pay, even if the employee has elected to receive CTO for the year.
- 3) When an employee's CTO bank is at the cap in Section 8.2.4, he or she may not accrue additional CTO and will be paid for

all overtime, even if he or she has elected to receive CTO for the year.

- 4) Any compensatory hours accumulated in the calendar year over eighty (80) hours will be cashed out in the full pay period including November 1.

### 8.3 Work Schedule

All work schedule and flexible time work schedule arrangements presently in effect shall continue. If the City proposes to change the work schedule of a classification the Union shall be notified at least fifteen (15) working days in advance and given an opportunity to meet and consult over such proposed changes prior to implementation.

## ARTICLE 9: UNIFORMS

- 9.1 The City will provide uniforms, raingear, coveralls or shop coats when necessary for all Public Works, Engineering, and applicable Building and Planning Department employees, consistent with existing practice.

- 9.2 Technical Services Manager(s) shall upon initial appointment be provided required uniforms as determined by the Chief of Police, and thereafter receive Six Hundred Dollars (\$600.00) per year uniform allowance in the amount of \$23.077 per biweekly pay period. If an eligible employee is on unpaid leave for a period of one (1) full pay period or more, the employee will not receive uniform allowance pay for that period.

The City will provide uniform jackets for City Service Employees whose work is primarily outdoors. Jackets that are worn or damaged in the course of work will be routinely replaced by the City. It will be the employee's obligation to replace lost or misplaced jackets.

If any other employee is required to wear a uniform during the life of this Memorandum of Understanding, the City will meet and confer with the Union concerning the establishment of an equitable uniform allowance.

- 9.3 On presentation of appropriate receipts, the City shall reimburse employees who are required by the City to wear safety shoes/boots for up to Two Hundred Eighty-Five Dollars (\$285.00) toward the cost of no more than three (3) pairs of OSHA approved safety shoes/boots per year. Employees in the Public Works Department assigned to the tree crew shall be reimbursed for up to Three Hundred Forty Dollars (\$340.00) toward the cost of no more than three (3) pairs of OSHA approved safety shoes/boots per year. Shoe repair and resoling are reimbursable under this provision. Shoes/boots purchased under this provision are for the use of the employee exclusively. So long as all required documents are submitted, reimbursements will be processed within two (2) pay periods following supervisory approval. Supervisors will approve or deny (with explanation) within 10 days of the submission.

9.4 Employee clothing seriously damaged or destroyed in conjunction with employment duties will be reasonably replaced by the City.

9.5 The City shall reimburse the Fleet Supervisor in the Maintenance Division who, as a condition of employment, is required to provide his or her own tools and equipment. Reimbursement will be made for tools that the employee selects to purchase, or for tools required to be added to the inventory in order to carry out his or her duties. Reimbursement will be made on submission of receipts, but no more than twice per fiscal year. The City shall reimburse a maximum of one thousand dollars (\$1,000.00) per fiscal year. The reimbursement shall be administered in accordance with Maintenance Division policy. Effective July 1, 2016, the City shall reimburse a maximum of one thousand four hundred dollars (\$1,400) per fiscal year.

## ARTICLE 10: HOLIDAYS

### 10.1 Fixed Holidays

Except as otherwise provided, employees within the representation unit shall have the following fixed holidays with pay:

New Year's Day	January 1
Martin Luther King Day	Third Monday in January
Washington's Birthday	Third Monday in February
Memorial Day	Last Monday in May
Independence Day	July 4
Labor Day	First Monday in September
Veterans Day	November 11
Thanksgiving	Fourth Thursday in November
Day after Thanksgiving	Fourth Friday in November
Christmas Eve	December 24
Christmas Day	December 25

10.1.1 In the event that any of the aforementioned days, except December 24, falls on a Sunday, the following Monday shall be considered a holiday. In the event that any of the aforementioned days falls on a Saturday, the preceding Friday shall be considered a holiday. In the event that December 24 falls on a Sunday, then the preceding Friday shall be considered a holiday.

10.1.2 Pay for Fixed Holidays. All full-time employees shall be paid a full day's eight (8) hours pay at their regular straight time base hourly rate for all fixed holidays as defined herein. All part-time workers shall be entitled to holiday leave with pay for the number of hours each holiday based on the number of hours per week such part-time worker is indefinitely assigned to work in the employee's regularly scheduled part-time position.

10.1.3 Work on Fixed Holidays. Any employee required to work on a fixed holiday and in addition to holiday pay shall be compensated at time and

one-half for such work. Work on a fixed holiday beyond the number of hours in the regular shift being worked on the holiday shall be compensated at double time.

- 10.1.4 An employee who is scheduled to work on a designated City holiday, and subsequently calls in sick, the employee shall not receive holiday pay.

## 10.2 Floating Holiday Time

Employees shall annually receive thirty-four (34) floating holiday hours off with pay, credited on the first pay period of the year. Employees hired after the first pay period of the year shall receive a pro-rated amount of floating holiday hours for the remainder of the calendar year.

On a one-time only basis, employees shall receive 4 additional hours of floating holiday time that may be used between September 27, 2017 and October 10, 2017. If these four hours are not used October 10, 2017, the hours will be automatically cashed out on October 20, 2017.

The following conditions will apply to such floating days off:

- 10.2.1 Employees shall request a floating day off in accordance with normal vacation time off request procedure. In cases of conflicting requests for the same day made at the same time, length of service shall govern who receives the day off.
- 10.2.2 Floating days off must be used during or prior to the end of the twenty-sixth (26) pay period of the year in which it was credited or be forfeited.
- 10.2.3 If an employee fails to take a day off as scheduled, the day off so scheduled will be forfeited, unless a mutually agreeable alternative day off is arranged.
- 10.2.4 Any floating day off for employees who work less than full-time or less than a full year shall be prorated on the basis of hours worked as compared to full-time employment.
- 10.2.5 Floating holiday balances remaining at the time of separation will be forfeited. Employees who are laid off shall be permitted to exhaust their floating holiday balance prior to layoff, subject to department head approval, considering the needs of the department, specifically with regard to the employee's assigned duties and the employee's desires.

## ARTICLE 11: VACATIONS

- 11.1 Each employee shall be entitled to an annual paid vacation, accrued as follows:

11.1.1 For full-time employees:

Less than three (3) years of service - 88 hours per year.

Three (3) years of service through five (5) years of service - 104 hours per year.

Six (6) years of service through ten (10) years of service - 136 hours per year.

Eleven (11) years of service through fifteen (15) years of service - 152 hours per year.

Over fifteen (15) years of service - 176 hours per year.

11.1.2 For permanent part-time employees: a proportional equivalent based on the assigned number of hours worked per week as compared to those worked by a full-time employee.

11.2 Maximum Accrual

Vacation may be accrued up to a maximum of three hundred thirty-six (336) hours for full time employees, and a prorated amount for permanent part time employees. After reaching said maximum, the employee must take time off or accrual will be frozen. Upon separation, there will be no payment for hours in excess of the maximum accrual.

11.3 Vacation Scheduling

11.3.1 The department head shall determine the vacation schedule considering the needs of the department, specifically with regard to the employee's assigned duties and the employee's desires. Use of vacation is subject to the advanced approval of the Department Director or designee. Any and all vacation granted pursuant to this Article shall be granted at time or times as will not reduce the number of employees below that which is reasonably necessary for the efficient conduct of the public business of such department, division or work group. Vacation time requested shall not be unreasonably denied.

11.3.1.1 Vacation Scheduling for Personal Business

11.3.1.2 An employee shall be entitled to a maximum of three (3) vacation days per year for personal business. Such leave shall be deducted from accrued vacation or compensatory time.

11.3.1.3 Personal Business is defined as business of urgent and compelling importance which cannot be taken care of outside of normal working hours and which is not covered under other leave provisions of this Memorandum of Understanding or state and federal laws.



11.3.1.4 An employee shall notify the department head two (2) days before taking this leave, unless an emergency exists which prohibits the employee from providing such advance notice.

11.3.1.5 Requests shall be considered in accordance with Section 11.3.1 above.

#### 11.4 Payment on Separation

Accrued vacation time up to the maximums described in Section 11.2 above shall be paid to an employee permanently separated from City service.

#### 11.5 Vacation Cashout

An employee may cash out vacation leave in accordance with the vacation Cashout Policy.

### ARTICLE 12: LEAVE PROVISIONS

#### 12.1 Sick Leave

12.1.1 Accrual Rates. The City shall provide each employee with paid sick leave at the rate of eight hours per month, earned on a biweekly basis and computed as follows:

12.1.1.1 Full-time employees may accrue up to a maximum of one thousand four hundred forty (1,440) hours, and a proportional equivalent for part-time employees.

12.1.2 Use of Sick Leave. Sick leave shall be allowed and used in cases of actual personal sickness or disability, medical or dental treatment, or as authorized for other necessary health reasons. Up to six (6) days per year of sick leave may be used in cases of actual sickness or disability, medical or dental treatment of members of the employee's immediate family.

If an employee is scheduled to work on a designated City holiday, and subsequently calls in sick, the employee shall not receive holiday pay.

12.1.3 Abuse Enforcement. The City shall be obligated to monitor all sick leave use, and shall take appropriate actions to ensure that benefits are paid out only for use as authorized in Section 12.1.2.

12.1.3.1 Any employee who does not have an accrued sick leave balance and who does not otherwise qualify under the provisions of this Article 12, shall not be paid for any day of sick leave called in, whether genuine or not.

- 12.1.3.2 Management has the authority to monitor potential sick leave abuse and patterns of abuse, and when there is a reasonable basis for suspecting such abuse, may require medical verification as a condition for payment of sick leave.
- 12.1.4 Except for urgent and compelling reasons, employees who are not at work due to a non-work related illness or injury should not be contacted during their absence. This Section does not modify the provisions of Section 12.1.3.
- 12.1.5 Compensation for Accumulated Sick Leave.
- 12.1.5.1 Resignation. A resigning employee who has fifteen (15) or more years of continuous service shall receive compensation for up to fifteen percent (15%) of his/her accumulated sick leave balance up to a maximum of five hundred (500) hours. Such compensation shall be based on the employee's rate of pay on his/her last day of paid service to the City.
- 12.1.5.2 Retirement. An employee who retires under PERS from the City may elect to receive cash compensation for fifteen percent (15%) of his or her accumulated sick leave balance, up to a maximum of one thousand three hundred sixty (1,360) hours, based upon the employee's rate of pay on his or her last day of paid service to the City. If the employee was hired by the City prior to October 23, 2011, he or she may alternately convert their sick leave balance, up to a maximum of one thousand three hundred sixty (1,360) hours, to retirement health credits at the rate prescribed in Section 12.1.5.3. Employees may combine any of the above two options.
- 12.1.5.3 An employee with a minimum of five (5) years of continuous service hired by the City prior to October 23, 2011 may elect to convert accumulated sick leave to retirement health credits upon retirement from the City according to the following schedule:
- Five (5) years of service to fifteen (15) years of service: eight (8) hours of sick leave for each retirement health credit, with any remainder being rounded to the next higher credit;
- Fifteen (15) years of service to twenty (20) years of service: six (6) hours of sick leave for each retirement health credit, with any remainder being rounded to the next higher credit;
- Over twenty (20) years of service: three (3) hours of sick leave for each retirement health credit, with any remainder being rounded to the next higher credit.
- 12.1.5.4 Layoff. An employee hired by the City prior to October 23, 2011 may, upon layoff, after the health insurance benefit paid

under Section 5.8.1 has been exhausted, convert up to a maximum of forty-eight (48) hours of the employee's accrued sick leave balance to retirement health credits at the rate prescribed in Section 12.1.5.3. If laid off with fifteen (15) or more years of continuous service, an employee may elect to receive compensation for up to fifteen percent (15%) of his/her accumulated sick leave balance up to a maximum of five hundred (500) hours, and may combine such option with the retirement health credit conversion described in this subsection if hired by the City prior to October 23, 2011, provided he/she has sufficient accumulated sick leave to do so. Under the compensation option, payout shall be based on the employee's rate of pay on his/her last day of paid service to the City.

- 12.1.6 Double Coverage. Employees who qualify for the retirement health credit conversion may elect double coverage at the rate of two (2) units for every month of paid health insurance.
- 12.1.7 Family Coverage. Employees who qualify for the retirement health credit conversion may elect family coverage at the rate of three (3) units for every month of paid health insurance.
- 12.1.8 Dental Coverage. Employees who qualify for the retirement health credit conversion may elect dental coverage at the rate of one-half (.5) unit for every month of paid dental insurance.
- 12.1.9 Transfer of Sick Leave for Catastrophic Illness. Transfer of sick leave for catastrophic illness is designed to assist employee who have exhausted sick leave due to a catastrophic illness, injury or condition of the employee. This policy allows other employees to make voluntary grants of time to that employee so that he/she can remain in a paid status for a longer period of time, thus partially ameliorating the financial impact of the illness, injury or condition.

A catastrophic illness is defined as an illness which has been diagnosed by a competent physician, requiring an extended period of treatment or recuperation, and which has a significant risk to life or life expectancy. Confirmation of the condition and prognosis by a health care provider chosen by the City may be required.

The Human Resources Department will discuss with AFSCME or their designated representative an appropriate method of soliciting contributions from coworkers. The contributions shall be submitted to Human Resources and Human Resources will process the contribution list in the order established. Any employee shall be allowed to contribute a maximum of eighty (80) hours of sick leave from their accrued sick leave balance to another full-time or permanent part-time employee in the City who is suffering from a catastrophic illness and has exhausted his or her own sick leave, provided, however, they have maintained a positive sick leave

balance of forty (40) hours or more following the donation. Once the contribution is made it cannot be rescinded.

Upon return to work, an employee may bank any remaining hours that have been contributed up to a maximum of forty (40) hours. If the contribution list has not been exhausted, the contributing employees will be notified that their contribution was not required and the balance restored.

## 12.2 Long Term Disability

12.2.1 Should any illness or injury extend beyond forty-five calendar (45) days, the City will ensure continued payment to the employee at 66.67 percent of salary, up to a maximum as provided in the long-term disability policy. The amounts paid shall be less any payments received from either Workers' Compensation or retirement. During the first year of disability and so long as no retirement determination has been made by the City, the employee will be entitled to continued City paid health insurance, AD&D, dental, vision and life insurance benefits providing that the employee continues to pay the employee share of the benefit cost, where applicable. Accrued leave earned shall only continue for periods during which the employee is utilizing accrued leave time.

12.2.2 Employees who have a sufficient amount of sick leave time may, at the employee's option, use sick leave on an hour-for-hour basis to delay the start of the long term disability plan. The long term disability plan would start upon the exhaustion of sick leave. The City procedures which allow for follow-up of an employee who has been out on an extended disability shall apply to employees under this section.

## 12.3 Leave Without Pay

12.3.1 Leaves of absence without pay may be granted in cases of personal emergency or when such absences would not be contrary to the best interest of the City.

12.3.2 Requests for leaves of absence without pay must be written and submitted to the department head and Human Resources Director. The Human Resources Director may grant a permanent employee leave of absence without pay for a period not to exceed one (1) year, during which time no benefits and no seniority credit will accrue. Approval shall be in writing and a copy filed with Human Resources. Upon expiration of a regularly approved leave, or within five (5) working days after notice to return to duty, the employee shall be reinstated in the position held at the time the leave was granted. Failure on the part of an employee on leave to report promptly at its expiration, or within three (3) working days after notice to report to duty, may be deemed notice of resignation and/or cause for disciplinary action.

12.3.3 Vacancies created as a result of leave without pay may be filled in the following manner:

- a) By temporary employees for a maximum of six (6) months;
- b) By provisional employees.

If a leave is extended beyond the initial fixed period, temporary employees may be held over for up to three (3) months (for a total term of employment of nine (9) months) in a temporary capacity. Provisional employees may be held over if a leave is extended, or, in cases where the position is vacated, for the duration of the recruitment period.

#### 12.4 Jury Duty and Subpoenas

12.4.1 An employee required to report for jury duty or to answer a subpoena as a witness on behalf of the City, provided the witness has no financial interest in the outcome of the case, shall be granted a leave of absence with pay from his/her assigned duties until released by the court, provided the employee remits to the City all fees received from such duties other than mileage or subsistence allowances within thirty (30) days from the termination of jury service.

12.4.2 This leave of absence with pay shall extend to employees' whose regular shift is a shift outside of the hours of 8:00 A.M. to 5:00 P.M., so that such employees shall not be required to work their regular shift on a day in which they perform jury duty or respond to a subpoena.

12.4.3 When an employee returns to complete a regular shift following time served on jury duty or as a witness, such time falling within work shift shall be considered as time worked for purposes of shift completion and overtime computation. In determining whether or not an employee shall return to his/her regular shift following performance of the duties above, reasonable consideration shall be given to such factors as travel time and a period of rest.

#### 12.5 Military Leave

Military leave of absence shall be granted and compensated in accordance with all applicable laws. Employees entitled to military leave shall give the appointing power an opportunity, within the limits of military regulations, to determine when such leave shall be taken.

#### 12.6 Bereavement Leave

An employee shall be allowed regular pay for not more than 24 hours (or a prorated amount for permanent part time employees) when absent because a death has occurred in the immediate family. For purpose of bereavement leave, members of the immediate family shall be limited to mother, stepmother, father, stepfather, mother-in-law, father-in-law, grandmother or grandfather of the employee, or spouse,

brother, stepbrother, sister, stepsister, child, grandchild, domestic partner or dependent of the employee.

To qualify for bereavement leave in the event of the death of a domestic partner, the employee must have filed a declaration of domestic partnership with the Human Resources Department prior to the request to utilize such leave.

Employees may use other appropriate leave for bereavement purposes for relations not included above provided such leave is approved in advance by the Department Director.

## 12.7 Maternity and Parental Leave

Employees are entitled to leaves of absence for maternity, parental bonding, and pregnancy-related disability. All such leaves of absence shall be granted and compensated in accordance with state and federal laws covering these topics, including the California Family Rights Act.

## 12.8 Miscellaneous Leave Provisions

12.8.1 Leaves of absence without pay which exceed four (4) weeks and are for leaves other than military shall not be included in determining seniority.

12.8.2 At the conclusion of a leave of absence an employee shall be returned to an equivalent position within his/her classification.

12.8.3 For any unpaid leave of absence the employee may elect to continue insurance coverage for up to the duration of his/her leave of absence at his/her own expense.

12.8.4 For any paid leave of absence, all benefits continue to accrue.

12.8.5 The Human Resources Director or designee will designate the specific beginning and ending dates to meet the needs of the employee and the City, which shall not be less than four weeks nor exceed one unpaid year.

12.8.6 At the conclusion of a leave of absence for any disability the employee may be required to submit a physician's statement certifying that he/she is medically qualified to resume work.

12.8.7 All provisions of this Article shall be administered in conformance with all Federal and State Laws.

## 12.9 Educational Leave and Tuition Reimbursement

12.9.1 The City shall contribute Four Thousand Dollars (\$4,000.00) annually on July 1st of each year to the AFSCME educational leave and tuition reimbursement fund. The City will reimburse expenses for tuition, books, lab fees and equipment, and curriculum fees incurred by an

employee, for classes completed in accredited institutions of learning or approved specialized training groups leading to an academic degree or improved job related skills. Parking fees or health fees related to enrollment will not be included. Programs must be approved in advance. Reimbursement will be provided upon successful completion of approved courses. Employees must attach a final grade of “C” or better for both undergraduate and graduate work. The employee may not elect to take a “pass-fail” grade if the letter system of grading is offered. Courses providing a “pass/fail” must achieve a “pass” to qualify for reimbursement. Funds expended on tuition reimbursement will be subject to appropriate IRS regulations. Employees wishing to engage in educational programs involving work time may be granted rescheduled time if departmental operations permit.

- 12.9.3 All employees assigned by the City to attend meetings, workshops, or conventions shall have their dues and reasonable expenses paid by the City and shall be allowed to attend such workshops, meeting and conventions on paid City time. Such required educational functions shall be reimbursed from departmental training funds and shall not be counted against the employee’s allowance or the annual tuition reimbursement.

Employees may under the tuition reimbursement fund request reimbursement for trade publications, technical books, and printed materials related to the employee’s employment.

- 12.9.4 Claims for qualified expenditures shall first be reimbursed to an individual maximum of seven hundred dollars (\$700) per fiscal year. After payment of all such claims, on June 30, should there be unused funds remaining in this fund, qualified claims in excess of seven hundred dollars (\$700) already paid, and received no later than July 15 of that year, shall be reimbursed on a pro-rata basis not to exceed a total annual individual reimbursement of Two Thousand Five Hundred Dollars (\$2,500).

## ARTICLE 13: BENEFIT PROGRAMS

### 13.1 Medical

- 13.1.1 The City shall make a direct contribution equal to the minimum employer contribution for agencies participating in the Public Employees Medical and Hospital Care Act (PEMHCA) on behalf of each active employee and qualified retiree.

~~13.1.2~~

13.1.2 The City shall continue to make a non-elective employer contribution to the flexible benefits plan on behalf of each active employee in an amount which, together with the minimum PEMHCA contribution in 13.1.1 equals the following:

\$2,351 per month - family coverage

\$1,811 per month - two-person coverage

\$961 per month - single coverage

[EXAMPLE: If the PEMHCA minimum contribution is \$140, then the City shall make a flexible benefits plan contribution of \$2,211 per month for family coverage, \$1,671 per month for two-person coverage and \$821 per month for single coverage.]

Cash-in-Lieu of Medical Coverage: Employees who waive coverage will be entitled to \$367.00 per month. Effective January 1, 2018, this amount is no longer contributed through the flexible benefits plan.

13.1.3 For the plan year beginning January 1, 2022, the City shall make a nonelective employer contribution to the flexible benefits plan on behalf of each active employee in an amount which, together with the minimum PEMHCA contribution in 13.1.1 equals the contributions in Section 13.1.2 increased by an amount equal to the twelve-month increase in the consumer price index (CPI-U San Francisco-Oakland-San Jose) measured from February 2020 to February 2021. However, the increase in the City's contribution shall be no less than two percent (2.0%) and no more than four percent (4.0%) (i.e., CPI 2-4%).

13.1.4 For the plan year beginning January 1, 2023, the City shall make a nonelective employer contribution to the flexible benefits plan on behalf of each active employee in an amount which, together with the minimum PEMHCA contribution in 13.1.1 equals the contributions in Section 13.1.3 increased by an amount equal to the twelve-month increase in the consumer price index (CPI-U San Francisco-Oakland-San Jose) measured from February 2021 to February 2022. However, the increase in the City's contribution shall be no less than two percent (2.0%) and no more than four percent (4.0%) (i.e., CPI 2-4%).

13.1.5 In the event that the City's contributions towards medical premiums are less than the Kaiser rate at each level of participation (single, two party, or family) for either plan year 2022 or plan year 2023, the parties will meet and confer in an attempt to address the differences between the City contribution and the Kaiser premium

The City shall continue to make a non-elective employer contribution to the flexible benefits plan on behalf of each active employee in an amount which, together with the minimum PEMHCA contribution in 13.1.1 equals the following:



~~————— \$2,212 per month ————— family coverage~~

~~————— \$1,665 per month ————— two-person coverage~~

~~————— \$839 per month ————— single coverage~~

~~————— [EXAMPLE: If the PEMHCA minimum contribution is \$128, then the City shall make a flexible benefits plan contribution of \$2,084 per month for family coverage, \$1,537 per month for two person coverage and \$711 per month for single coverage.]~~

~~————— Cash in Lieu of Medical Coverage: Employees who waive coverage will be entitled to \$367.00 per month. Effective January 1, 2018, this amount with no longer be contributed through the flexible benefits plan.~~

~~13.1.3 — For the plan year beginning January 1, 2019, the City shall make a non-elective employer contribution to the flexible benefits plan on behalf of each active employee in an amount which, together with the minimum PEMHCA contribution in 13.1.1 equals the following:~~

~~————— \$2,262 per month ————— family coverage~~

~~————— \$1,715 per month ————— two-person coverage~~

~~————— \$889 per month ————— single coverage~~

~~————— Cash in Lieu of Medical Coverage: Employees who waive coverage will be entitled to \$367 per month.~~

~~13.1.4 — For the plan year beginning January 1, 2020, the City shall make a non-elective employer contribution to the flexible benefits plan on behalf of each active employee in an amount which, together with the minimum PEMHCA contribution in 13.1.2 equals the following:~~

~~————— \$2,312 per month ————— family coverage~~

~~————— \$1,765 per month ————— two-person coverage~~

~~————— \$939 per month ————— single coverage~~

~~Cash in Lieu of Medical Coverage: Employees who waive coverage will be entitled to \$367.00 per month.~~

13.1.65 Each Active employee may use his/her allocated amount for any benefits permitted by law and provided for in the FSA plan document. The plan document will be amended to eliminate cash distributions, and to add employee-paid “buy up” of vision benefits.

13.1.76 Employees who have at least ten (10) continuous years of permanent service with the City and who retire under PERS shall be reimbursed by the City at the rate of one hundred dollars (\$100.00) per month toward the retiree’s employee only health care premium once the employee has exhausted the sick leave conversion to retiree health credits under Section

12.1.5.3. This reimbursement shall be in addition to the minimum employer contribution for agencies participating in the Public Employees' Medical and Hospital Care Act (PEMHCA). This section shall not apply to employees hired in a permanent classified position in this unit after October 23, 2009.

13.1.~~87~~ For part-time employees who are a member of the unit, the City shall prorate the dollar amount allocated under Sections 13.1.2, 13.1.3, and 13.1.4.

13.1.~~98~~ Employees whose medical insurance premium costs exceed the combined allocation available through the cafeteria plan and Section 13.1.1 shall have the excess cost of their medical premiums paid with before-tax compensation through a premium conversion plan.

13.1.~~10-9~~ Each employee must enroll in an available PEMHCA health insurance plan or demonstrate that he/she has health insurance coverage equivalent to the PEMHCA plan in order to receive the monthly amount for waiving coverage.

13.1.1~~10~~ Employees who wish to have domestic partners covered under the cafeteria plan may do so after filing the "Declaration of Domestic Partnership" form with the California Secretary of State and complying with any other requirements necessary to qualify for domestic partner health benefits under the PEMHCA health plans. It is understood that the premiums and benefits provided as a result of covering domestic partners may be taxable, and that the City will administer the program in accordance with State and Federal Tax regulations.

13.1.1~~21~~ The parties share an interest in addressing the increase in the cost of PEMHCA benefits. The City shall meet and confer with the Union prior to contracting with an alternative provider, consortia or group. However, the Union will have the option to remain in the PEMHCA program.

13.1.1~~32~~ Effective July 1, 2017, Cash-in-Lieu of Medical Coverage amounts will be included in the calculation of a regular rate for overtime purposes. In the event that a court issues a final decision holding that Cash-in-Lieu of Medical coverage payments do not need to be included in the regular rate, the City will cease including Cash-in-Lieu in the regular rate.

## 13.2 Dental

13.2.1 The City shall pay the full cost for Dental Insurance administered by Delta Dental or an equivalent third party administrator up to the annual maximums described in the summary plan description.

13.2.2 Dental benefits will be provided as described in the summary plan description.

13.3 Vision

The City shall continue to pay the full cost for fully insured Vision Insurance provided by VSP, or an equivalent insurance provider, providing vision benefits as described in the summary plan description.

13.4 Employee Assistance Program

The City shall continue to provide an employee assistance program to employees as currently provided.

13.5 Life Insurance

The City will provide to all employees life insurance at the rate of 1-1/2 times each employee's regular yearly wage.

ARTICLE 14: RETIREMENT

14.1 Retirement benefits for employees hired by the City prior to October 23, 2011, shall be those established by the California Public Employees' Retirement System (CalPERS) for local miscellaneous members 2.7% at age 55 formula, single highest year.

14.2 Retirement benefits for new employees hired by the City on or after February 12, 2012, who are not new members as defined by CalPERS, shall be those established by the California Public Employees' Retirement System (CalPERS) for local miscellaneous members 2.0% at age 60 formula, highest three years.

14.3 For new employees, as defined by CalPERS, hired on or after January 1, 2013, retirement benefits shall be those established by the California Public Employees' Retirement System (CalPERS) for Miscellaneous Members 2.0% at age 62 formula, highest three years.

14.4 The City shall pay none of the employee's contribution to CalPERS. The full unit member's contribution shall be deducted from the unit member's pay by the City and forwarded to CalPERS in accordance with the rules and regulations governing such contributions.

14.5 The City will continue to apply Internal Revenue Code 414 (h)(2) on the employee's contribution to CalPERS.

14.6 Beginning with fiscal year 2011-12, should the employer rate rise above 15.850%, the increase shall be shared equally between the employee and the employer. As an example, if the employer rate for 2011-12 is 16.000%, the City shall pay 15.925% and the employee shall pay 8.075% (inclusive of the 8.000% fixed employee contribution).

- 14.7 Effective as soon as practicable and after January 1, 2014, the employee contribution towards the employer's contribution to the Public Employees' Retirement System (CalPERS) shall be taken as a pre-tax deduction from the employees' paycheck each payroll period. The City and the Union agree that the employee contribution towards the employer's contribution will continue past the expiration of the MOU. If for any reason the City is precluded from making this deduction or the deduction cannot be made on a pre-tax basis, the parties agree to meet and confer regarding ways to cure the defect.

14.8 Committee for Employee Cost Share Reduction

The City and AFSCME will establish a labor management committee no later than 180 days prior to the expiration of the contract to study in good faith the impact of the additional cost share in section 14 of AFSCME MOU. AFSCME and the City will each appoint two (2) members to the committee, with additional members to be added by mutual agreement. The Parties intend the committee to inform negotiations over potential modification of the Cost Share as part of a successor MOU.

ARTICLE 15: GRIEVANCE PROCEDURE

15.1 Definitions

- 15.1.1 A grievance is an alleged violation, misinterpretation, or misapplication of the provisions of this Memorandum of Understanding, policy and/or procedure manuals affecting the working conditions of the employees covered by this Agreement
- 15.1.2 A "Disciplinary appeal" is an appeal from a disciplinary action of a Letter of Reprimand or higher, against an employee covered by this Memorandum of Understanding.
- 15.1.3 A "grievant" is any employee adversely affected by an alleged violation of the specific provision of this Memorandum, or the Union.
- 15.1.4 A "day" is any day in which the City Hall of Menlo Park is open for business.
- 15.1.5 The "immediate supervisor" is the lowest level administrator who has been designated to adjust grievances and who has immediate jurisdiction over the grievant.

15.2 General Provisions

- 15.2.1 Every effort will be made by the parties to settle grievances at the lowest possible level.
- 15.2.2 All documents dealing with the processing of a grievance shall be filed separately from the personnel files of the participants.

- 15.2.3 No party to a grievance shall take any reprisals against the other party to the grievance because the party participated in an orderly manner in the grievance procedure.
- 15.2.4 Failure of the grievant to adhere to the time deadlines shall mean that the grievance is settled. The grievant and the City may extend any time deadline by mutual agreement.
- 15.2.5 Every effort will be made to schedule meetings for the processing of grievances at times which will not interfere with the regular work day of the participants.
- 15.2.6 Either the City or the Grievant may be represented at any step of the grievance procedure by an individual of the party's choice.
- 15.2.7 Any employee may at any time present grievances to the City and have such grievances adjusted without the intervention of the Union, as long as the adjustment is reached prior to advisory arbitration and is not inconsistent with the terms of this Memorandum; provided that the City shall not agree to a resolution of the grievance until the Union has received a copy of the grievance and the proposed resolution and has been given the opportunity to file a response. Upon request of the grievant, the grievant may be represented at any stage of the grievance procedure by a representative of the Union.
- 15.2.8 Failure of a unit member to file a grievance over an adverse action which constitutes a "grievance" as defined herein shall not constitute a waiver of other unit members' rights to file future grievances involving the same or similar adverse actions.
- 15.2.9 The City and Union may agree to consolidate grievances at Level II and beyond.

15.3 Grievance Procedure (for grievances as defined in 15.1.1)

Grievances will be processed in accordance with the following procedures.

15.3.1 Level I - Immediate Supervisor

- 15.3.1.1 Any employee who believes he/she has a grievance shall present the grievance orally to the immediate supervisor within ten (10) days after the grievant knew, or reasonably should have known, of the circumstances which form the basis for the grievance. Failure to do so will render the grievance null and void. The immediate supervisor shall hold discussions and attempt to resolve the matter within ten (10) days after the presentation of the grievance. It is the intent of this informal meeting that at

least one (1) personal conference be held between the aggrieved employee and the immediate supervisor.

15.3.2 Level II - Department Director

15.3.2.1 If the grievance is not resolved at Level I and the grievant wishes to press the matter, the grievant shall present the grievance in writing on the appropriate form to the Department Director within ten (10) days after the oral decision of the immediate supervisor. The written information shall include:

- a) a description of the specific grounds of the grievance including names, dates, and places necessary for a complete understanding of the grievance;
- b) a listing of the provisions of this Memorandum which are alleged to have been violated;
- c) a listing of the reasons why the immediate supervisor's proposed resolution of the problem is unacceptable; and
- d) a listing of specific actions requested by the grievant of the City which will remedy the grievance.

15.3.2.2 The Department Director or designee shall communicate the decision to the grievant in writing within ten (10) days after receipt of the grievance. If the Department Director or designee does not respond within the time limits, the grievant may appeal to the next level.

15.3.2.3 With the concurrence of the City, an employee or the Union may choose to file the formal grievance initially at Level II (the Department Director) instead of Level I.

15.3.2.4 Within the above time limits either party may request a personal conference.

15.3.3 Level III - Appeal to City Manager

15.3.3.1 If the grievant is not satisfied with the decision at Level II, the grievant may, within ten (10) days of the receipt of the decision at Level II, appeal the decision to the City Manager. The statement shall include a copy of the original grievance, all decisions rendered and a clear and concise statement of the reasons for the appeal.

15.3.3.2 The City Manager or designee shall respond to the grievance in writing within ten (10) days of receipt of the written appeal.

#### 15.3.4 Level IV - Arbitration

- 15.3.4.1 If the grievant is not satisfied with the decision at Level III, the grievant may within five (5) days of the receipt of the decision submit a request in writing to the Union for arbitration of the dispute. Within fifteen (15) days of the grievant's receipt of the decision at Level III, the Union shall inform the City of its intent as to whether or not the grievance will be arbitrated. The Union and the City shall attempt to agree upon an arbitrator. If no agreement can be reached, they shall request that the State Mediation and Conciliation Service supply a panel of five (5) names of persons experienced in hearing grievances involving City employees and who are members of the National Academy of Arbitrators (NAA). Each party shall alternately strike a name until only one (1) name remains. The remaining panel member shall be the arbitrator. The order of striking shall be determined by lot.
- 15.3.4.2 If either the City or the Union so requests, a separate arbitrator shall be selected to hear the merits of any issue raised regarding the arbitrability of a grievance. No hearing on the merits of the grievance will be conducted until the issue of arbitrability has been decided. The process to be used in selecting an arbitrator shall be as set forth in 15.3.4.1.
- 15.3.4.3 The arbitrator shall, as soon as possible, hear evidence and render a decision on the issue or issues submitted to him/her. If the parties cannot agree upon a submission agreement, the arbitrator shall determine the issues by referring to the written grievance and the answers thereto at each step.
- 15.3.4.4 The City and the Union agree that the jurisdiction and authority of the arbitrator so selected and the opinions the arbitrator expresses will be confined exclusively to the interpretation of the express provision or provisions of this Memorandum at issue between the parties. The arbitrator shall have no authority to add to, subtract from, alter, amend, or modify any provisions of this Memorandum or impose any limitations or obligations not specifically provided for under the terms of this Memorandum. The arbitrator shall be without power or authority to make any decision that requires the City or the administration to do an act prohibited by law.
- 15.3.4.5 After a hearing and after both parties have had an opportunity to make written arguments, the arbitrator shall submit in writing to all parties his/her findings and award.
- 15.3.4.6 The arbitrator shall make a final and binding determination.

15.3.4.7 The fees and expenses of the arbitrator shall be shared equally by the City and the Union (including the cost of any list of arbitrators requested pursuant to Section 15.3.4.1). All other expenses shall be borne by the party incurring them, and neither party shall be responsible for the expense of witnesses called by the other. Either party may request a certified court reporter to record the entire arbitration hearing. The cost of the services of such court reporter shall be paid by the party requesting the reporter or shared by the parties if they both mutually agree. If the arbitrator requests a court reporter, then the costs shall be shared by both parties.

#### 15.4 Disciplinary Appeals

- 15.4.1 A “disciplinary appeal” is a formal written appeal of a Notice of Disciplinary Action (post-Skelly) of any punitive disciplinary action including dismissal, demotion, suspension, reduction in salary, letters of reprimand, or transfer for purposes of punishment. However, letters of reprimand are not subject to the arbitration provisions of this procedure. This procedure also shall not apply to the rejection or termination of at will employees, including those in probationary status. Any reduction in pay for change in assignment which occurs in the course of regular rotation and is not punitive shall not be subject to this procedure.
- 15.4.2 Persons on probationary status (entry-level or promotional) may not appeal under this agreement rejection on probation.
- 15.4.3 Letters of Reprimand may be appealed under this section only to the City Manager level (Section 15.4.4.)
- 15.4.4 Any appeal to any punitive disciplinary action (as defined in Section 15.1.2) shall be presented in writing to the City Manager within ten (10) days after receipt of the Notice of Disciplinary Action. Failure to do so will be deemed a waiver of any appeal. The City Manager or designee shall hold a meeting to hear the appeal within ten (10) days after the presentation of the appeal and shall issue a decision on the appeal within ten (10) days after the presentation of the appeal. For letters of reprimand, the City Manager’s decision shall be final. However the employee may write a response and have that response included in his or her personnel file.
- 15.4.5 For appeals of dismissal, demotion, suspension, or reduction in salary, if the employee is not satisfied with the decision of the City Manager, the employee may, within ten (10) days of the receipt of the decision, submit a request in writing to the Union for arbitration of the dispute. Within twenty (20) days of the City Manager’s decision, the Union shall inform the City of its intent as to whether or not the disciplinary matter will be arbitrated. The Union must be the party taking the matter to arbitration.



- 15.4.6 The parties shall attempt to agree to the selection of an arbitrator and may agree to strike names from a list provided by an outside agency such as the State Mediation and Conciliation Service. However, in the event that the City and the Union cannot agree upon the selection of an arbitrator within forty-five (45) days from the date that the Union has notified the City of its intent to proceed to Arbitration, either party may request a list of five (5) labor arbitrators who shall be retired judges of the Superior Court of the County of San Mateo. The Union and City shall attempt to agree to the selection of a retired judge. If no agreement can be reached, each party shall alternately strike a name from the list until one (1) name remains, who shall serve as the arbitrator.
- 15.4.7 The City and Union agree that the arbitrator shall prepare a written decision containing findings of fact, determinations of issues and a disposition either affirming, modifying or overruling the disciplinary action being appealed. The parties expressly agree that the arbitrator may only order as remedies those personnel actions which the City may lawfully impose.
- 15.4.8 The fees and expenses of the arbitrator (including the cost of any list of arbitrators) shall be shared equally by the City and Union. All other expenses shall be borne by the party incurring them, and neither party shall be responsible for the expense of witnesses called by the other. Either party may request a certified court reporter to record the entire arbitration hearing. By mutual agreement, the cost of the services of such court reporter shall be shared equally by the parties. However, each party shall be responsible for the cost of transcripts that they order.
- 15.4.9 Nothing herein constitutes a waiver of City or employee rights otherwise granted by law.

## ARTICLE 16: EFFECT ON EXISTING PRACTICES

### 16.1 Changes in Personnel Rules and Department Regulations

During the term of this Memorandum of Understanding, the parties hereto will meet and confer regarding changes proposed by the City in the City's Personnel Rules and Department Rules and Regulations.

### 16.2 Effect of Agreement

This Agreement completely supersedes any prior agreements between the parties. It also supersedes any conflicting provision in the City's Personnel Rules.

### 16.3 Existing Practices

Existing practices and/or benefits which are not referenced in this Memorandum and which are subject to the meet and confer process shall continue without change unless modified subject to the meet and confer process.

#### 16.4 Waiver Clause

Except as provided in Section 16.3, Existing Practices, the employees waive their right to meet and confer during the term of this Agreement on any matter raised during the meeting and conferring which preceded this Agreement.

### ARTICLE 17: NONDISCRIMINATION

17.1 The parties agree that they, and each of them, shall not discriminate against any employee on the basis of race, religion, color, creed, age, marital status, national origin, ancestry, sex, sexual orientation, medical condition or disability. The parties further agree that this Section shall not be subject to the Grievance Procedure provided in this Agreement.

17.2 The parties agree that they, and each of them, shall not discriminate against any employee because of membership or lack of membership in the Union, or because of any authorized activity on behalf of the Union. The parties further agree that this Section may be subject to the Grievance Procedure provided in this Agreement.

### ARTICLE 18: MANAGEMENT RIGHTS

18.1 Except to the extent that the rights are specifically limited by the provisions of this Agreement, the City retains all rights, powers, and authority granted to it or which it has pursuant to any law, including, but not limited to the rights to:

- Direct the work force;
- Increase, decrease or re-assign the work force;
- Hire, promote, demote; discharge or discipline for cause;
- Transfer or reclassify employees;
- Assign employees days of work, shifts, overtime and special work requirements, and
- Determine the necessity, merits, mission and organization of any service or activity of the City or of any City Department, Agency or Unit.

18.2 The City has the sole and absolute right to determine the nature and type of, assign, reassign, revoke assignments of or withdraw assignments of, City equipment, including motor vehicles, to or from employees during, after or before hours of duty; to determine the methods, means and numbers and kinds of personnel by which City operations are to be conducted, including the right to contract or subcontract bargaining unit work provided that the City will meet and confer in advance on the impact of subcontracting on work load and safety and any other matter within the scope of representation.

18.3 The exercise of the foregoing powers, rights, authority, duties, and responsibilities by the City, the adoption of policies, rules, regulations and practices in furtherance thereof, and the use of judgment and discretion in connection therewith shall be

limited only by the specific and express terms of this Memorandum and then only to the extent such specific and express terms hereof are in conformance with the Constitution and laws of the United States and the Constitution and laws of the State of California.

- 18.4 The exercise by the City through its Council and management representatives of its rights hereunder shall not in any way, directly or indirectly, be subject to any grievance procedure nor subject to meeting and conferring.

#### ARTICLE 19: CONCERTED ACTIVITIES

- 19.1 As used in this Article 19, “strike or work stoppage” means the concerted failure to report for duty, the willful absence from one’s position, the stoppage of work, or the abstinence in whole or in part from the full, faithful performance of the duties of employment for the purpose of inducing, influencing or coercing a change in the conditions of compensation, or the rights, privileges or obligations of employment.
- 19.2 It is agreed and understood that there will be no strike, work stoppage, slowdown, or refusal to fully and faithfully perform job functions with responsibilities, or any interference with the operations of the City, or any concerted effort designed to improve its bargaining position which interferes with, impedes, or impairs City operations by the Union or by its officers, agents or members. The Union agrees that neither the Union nor its officers, agents or members will, in any manner whatsoever, honor, assist or participate in any picketing activities, sanctions or any other form of interference with City operations by any other non-unit employees or members of other employee associations or groups.
- 19.3 Furthermore, the Union agrees that the provisions in this Article 19 are enforceable by the City in a Court of law. The City may, upon its own election, initiate such court action as it deems appropriate to enjoin or impose damages on the Union, its officers, agents or members for activities referred to herein.
- 19.4 It is further agreed and understood that neither the Union nor its officers, agents, or members shall engage in any boycott, picketing or any other concerted attempts to discourage, impair or negatively affect the businesses of members of the City Council.
- 19.5 Nothing herein shall be deemed to limit the remedies available to the City in dealing with concerted activities as described hereinabove.

#### ARTICLE 20: SEPARABILITY

If any provision of this Agreement shall be declared void or unenforceable by a court of competent jurisdiction, the remaining provisions of this Agreement shall remain in full force and effect, except that either party to the Agreement may request the other party to meet and confer in regard to amending the Agreement to replace the provisions declared void or

unenforceable. However, there will be no obligation on either party to agree on a replacement provision.

## ARTICLE 21: DISCIPLINARY ACTION

- 21.1 For just cause, the City has the right to discipline, demote, or discharge permanent employees for unsatisfactory work or conduct. Disciplinary action, if taken must be acted upon within forty-five (45) days of the date of discovery of the basis for the discipline unless the City demonstrates that at the end of the forty-five (45) day period, it was engaged in an active, ongoing investigation of the allegations.
- 21.2 Non-probationary employees whose work or conduct is unsatisfactory but not sufficiently deficient to warrant discipline, demotion, or discharge will be given a written notification of unsatisfactory work or conduct and an opportunity to improve. Failure to correct deficiencies and improve to meet standards may result in discipline, demotion or discharge. Reprimands shall not be subject to the arbitration provisions of Article 15, Disciplinary Appeals.
- 21.3 Notice of disciplinary action must be in writing and served on the employee and their authorized Union representative in person or by certified and regular mail prior to the disciplinary action becoming effective. The notice must be filed on a timely basis with the Human Resources Department and included in the employee's personnel file. The notice of disciplinary action shall include:
- 21.3.1 Statement of the nature of the disciplinary action;
  - 21.3.2 Effective date of the action;
  - 21.3.3 Statement of the reasons for the proposed action;
  - 21.3.4 Statement in ordinary and concise language of the act or the omissions upon which the reasons for the proposed disciplinary action are based.
  - 21.3.5 In all cases of disciplinary action, the notice shall include a statement advising the employee of his/her right to appeal such action and the right to Union representation.
- 21.4 In cases of demotion, discharge, or suspension of employees in permanent status, the notice of intended discipline shall include a statement of the employee's right to respond, either orally, at a meeting requested by the employee, or in writing. The opportunity to respond shall be afforded prior to the action becoming effective, but the employee must respond no later than five (5) days after receipt of notice of intended disciplinary action. A conference, if requested, shall be scheduled and held as soon as possible but in no event later than thirty (30) days after receipt of notice of intended disciplinary action.
- 21.5 Nothing herein shall prohibit the Union from discussing the issue of a time limit on the duration in which the disciplinary action will remain in the employee's personnel

file, however, by entering into such discussions, there shall be no commitment on the part of the City to agree to a time limit.

## ARTICLE 22: TRANSFER

### 22.1 Definition

For purposes of this Article, a “transfer” shall consist of a change in work location of an employee from one work site to another work site within the City. Such a transfer does not encompass the process of assignment of a specific position and responsibilities within the department or work location. An employee assigned to more than one work site shall be considered as being transferred only when moved from one City-wide program to another program. A transfer may be initiated by an employee (“voluntary”) or by the City (“administrative”).

### 22.2 Voluntary Transfers as a Result of Posting and Filling Vacancies

- 22.2.1 A “vacancy” is a new position, an opening arising from a resignation, retirement, or termination, any position to which an employee is not assigned or which is not committed for purposes of leaves, unresolved administrative transfers or layoffs.
- 22.2.2 Notices of vacancies shall be posted for at least five (5) working days on the bulletin board in the City’s administrative offices. Such notices shall be posted as soon as the City determines that a vacancy exists and shall include the position description, location, and other special requirements. A copy of the vacancy notice shall be forwarded to the Union President and a second copy shall be forwarded to the Union office.
- 22.2.3 The request for transfer will be sent to the Human Resources Director with a copy to the Department Director. A conference shall be held at the request of the employee or the Human Resources Director in order to discuss the request.
- 22.2.4 For purposes of selection between two or more employees requesting transfer to a vacant position, the City shall consider the training experience, competencies, length of service in the City, past evaluations, and qualifications of each employee.
- 22.2.5 When the City has considered two or more employees requesting a transfer to a vacant position to be relatively equal on the basis of training, experience, competence, past evaluations, and qualifications, the employee with the most City-wide seniority shall be selected for transfer to the vacant position.
- 22.2.6 The City shall notify the employee requesting transfer, in writing, of the City’s acceptance or denial of the request. The City shall provide written reasons for not granting the transfer request upon the request of the

employee. Transfer requests shall be acted upon prior to filling positions by promotion or outside applicants.

22.2.7 Only one (1) voluntary transfer may be granted per employee in any one (1) year period.

### 22.3 Administrative Transfers

22.3.1 An administrative transfer may be initiated by the Human Resources Director or his/her designee and shall be based exclusively on the work related special needs of the City and/or welfare of the employees involved and will not be for punitive or capricious reasons.

22.3.2 In the event that circumstances require that an employee be transferred on an administrative basis, the employee and the Union shall be informed of the reason(s) in writing prior to such action and shall be afforded an opportunity to meet with the Human Resources Director regarding the proposed transfer.

22.3.3 For purposes of selecting which employee shall be administratively transferred in order to meet the needs of the City, the City shall consider the training, experience, competencies, length of service in the City, past evaluations, qualifications, and current classification of each employee considered. All things being relatively equal, the employee with the least City-wide seniority will be transferred.

22.3.4 If total time of service with the City for two (2) or more employees considered equal is the same, then, as between those employees, the transfer will be determined by a lottery.

### 22.4 Length of Service Defined

22.4.1 For the purpose of this Article, "length of service" means all hours in paid status including holiday, vacation, and paid leave, but does not include any hours compensated for overtime or standby, military leave, unpaid illness, unpaid industrial accident leave, or hours served as a temporary or contract employee in a classification other than the classification from which the employee is being transferred.

22.4.2 No seniority credit shall be earned during periods of separation from service with the City, including suspension without pay as a result of disciplinary action.

## ARTICLE 23: SAFETY

23.1 It is the City's intention to provide the safest possible equipment and working conditions to the workforce of the City of Menlo Park. Toward that end, the City is committed to making the necessary expenditures to purchase this equipment.

23.2 The Union and the City agree to continue to participate in the City Safety Committee.

ARTICLE 24: TERM OF AGREEMENT

This Agreement shall remain in full force and effect up to and including June 30, 202~~30~~, and thereafter shall continue in effect year by year unless one of the parties notifies the other in writing no earlier than ninety (90) days prior to the expiration or subsequent contract anniversary and no later than sixty (60) days prior to the expiration or subsequent contract anniversary, of its request to modify, amend, or terminate the Agreement. If the parties enter into subsequent meeting and conferring regarding a successor agreement, the terms and conditions of this Agreement shall remain in effect until a successor Agreement is reached, or until meeting and conferring is concluded.

In order to comply with City policy, tentative agreements must be posted 15 days in advance.

The terms of this Agreement shall be effective upon the adoption of this Agreement by the City Council except as otherwise provided by specific sections of this Agreement.

Dated: \_\_\_\_\_

City of Menlo Park

Local 829, A.F.S.C.M.E., AFL-CIO

\_\_\_\_\_

\_\_\_\_\_

\_\_\_\_\_

\_\_\_\_\_

APPENDIX "A"  
CLASSIFICATIONS REPRESENTED BY  
AMERICAN FEDERATION OF STATE, COUNTY AND MUNICIPAL EMPLOYEES,  
LOCAL 829, AFL-CIO

Business Manager  
Communications and Records Manager  
Custodial Services Supervisor  
Information Technology Supervisor  
Literacy Program Manager  
Management Analyst II  
Permit Manager  
Principal Planner  
Public Works Supervisor – City Arborist  
Public Works Supervisor – Facilities  
Public Works Supervisor – Fleet  
Public Works Supervisor – Parks  
Public Works Supervisor – Streets  
Recreation Coordinator  
Recreation Supervisor  
Revenue and Claims Manager  
Senior Accountant  
Senior Building Inspector  
Senior Civil Engineer  
Senior Librarian  
Senior Transportation Engineer  
Water System Supervisor





## APPENDIX "C"

### Menlo Park Labor Management Committee (LMC)

#### GOAL

The Union and Management have a sincere desire to maintain and improve their progressive, mature and cooperative labor relations/personnel relationship throughout the length of the contract.

#### MEETINGS

In order to facilitate this, the parties agree to meet as necessary to discuss work and personnel/labor relations related issues of interest to either the employees or management. These meetings shall not replace informal grievance meetings nor the responsibilities of the parties to meet and confer pursuant to the law and the agreement. However topics may include preliminary discussions of matters which may later develop into more formal concerns to be dealt with in official forums.

#### PARTICULARS

In attendance will be representatives from the City of Menlo Park, as determined by the issues to be discussed. A Union staff person and three members selected by the union shall represent the employees. Additional department heads, members or consultants may be included as necessary.

Agenda shall be set in advance and mutually agreed to except that there shall be a regular item for either party to confirm or dispel rumors in labor relations/personnel topics since the last meeting.

Additional meetings may be set with mutual agreement.

Minutes shall be taken with each side alternately taking responsibility for taking and reproducing them. Confidential personal issues shall be discussed off the record and summarized in the minutes.

#### CALPERS LABOR MANAGEMENT COMMITTEE (CLMC)

Effective for the term of this agreement, the City and Union agree to the establishment of a CalPERS Labor Management Committee (CLMC) to serve as an advisory committee and to facilitate employee education and involvement in issues regarding CalPERS retirement benefits, including but not limited to, potential future costs increases and the impacts of said cost increases to the financial stability of the City.

The City and the Union shall each select their own representatives and in equal number, with no more than three (3) on each side. Each side is encouraged to propose issues for discussion, and the committee will jointly set priorities. Decision making within this forum will be by consensus. The CLMC will set up regular meetings to occur not less than once per quarter and a means for calling additional meetings to handle issues on an ad hoc basis.

The CLMC is not authorized to meet and confer or create contractual obligations nor are they to change the MOU to authorize any practice in conflict with existing contracts or rules.

#### DISABILITY INSURANCE LABOR MANAGEMENT COMMITTEE (DI-LMC)

Effective for the term of this agreement, the City and union agree to the establishment of a Labor Management Committee to explore the possibility of enhancing disability insurance benefits.

The City and the Union shall each select their own representatives and in equal number, with nor more than three (3) on each side. The DI-LMC is not authorized to meet and confer or create contractual obligations nor are they to change the MOU to authorize any practice in conflict with existing contracts or rules.

The City and Union will consider recommendations of the DI-LMC and will meet and confer over those recommendations, but neither will be under any obligation with regard to DI-LMC's recommendations.

**RESOLUTION NO. 6649**

**RESOLUTION OF THE CITY COUNCIL OF THE CITY OF MENLO PARK  
APPROVING AND ADOPTING THE COMPREHENSIVE MEMORANDUM OF  
UNDERSTANDING WITH AMERICAN FEDERATION OF STATE, COUNTY,  
AND MUNICIPAL EMPLOYEES LOCAL 829 WITH A TERM OF JULY 1, 2021  
THROUGH JUNE 30, 2023**

WHEREAS, the City of Menlo Park received a report on expiring labor agreements on February 9, 2021 in accordance with City Council’s policy on Public Input and Outreach Regarding Labor Negotiations; and

WHEREAS, the Memorandum of Understanding (“MOU”) between the City of Menlo Park (“City”) and the American Federation of State, County, and Municipal Employees Local 829 (“AFSCME”) expired on June 30, 2021; and

WHEREAS, Negotiators for City and AFSCME began the meet and confer process on March 25, 2021, and met four times before reaching tentative agreement (TA) on a successor MOU on June 18, 2021; and

WHEREAS, City and the AFSCME have met and conferred in good faith and have agreed to the attached comprehensive successor MOU (Exhibit A); and

WHEREAS, the terms of the successor MOU make changes to the wages, flexible benefit plan contributions, and one-time lump sum payments in 2021 and 2022 and has a term July 1, 2021 through June 30, 2023; and

WHEREAS, AFSCME membership ratified the TA set forth in Exhibit A on June 21, 2021; and

NOW THEREFORE, THE CITY COUNCIL OF THE CITY OF MENLO PARK HEREBY RESOLVES THAT:

1. City ratifies the TA with AFSCME for a successor MOU with a term of July 1, 2021 through June 30, 2023, as set forth in Exhibit A attached and incorporated by reference.
2. City Council authorizes the city manager to execute the successor MOU.
3. City Manager may approve formatting edits to the successor MOU.

I, Judi A. Herren, City Clerk of Menlo Park, do hereby certify that the above and foregoing City Council Resolution was duly and regularly passed and adopted at a meeting by said City Council on the seventeenth day of August, 2021, by the following votes:

//  
  
//  
  
//  
  
//  
  
//

AYES:

NOES:

ABSENT:

ABSTAIN:

IN WITNESS WHEREOF, I have hereunto set my hand and affixed the Official Seal of said City on this seventeenth day of August, 2021.

---

Judi A. Herren, City Clerk

**MEMORANDUM**

**Date:** 7/9/2021  
**To:** Nick Pegueros, Assistant City Manager  
**From:** Dan Jacobson, Assistant Administrative Services Director  
**Re:** Pension cost-share background and factors

The City currently uses a cost-share with employees to defray total costs of providing pension benefits through the California Public Employee Retirement System (CalPERS), with a variety of differences between tiers and category of employee, whether miscellaneous or safety, as well as between bargaining groups. Under the terms currently included in the memoranda of understanding (MOUs) between the City and its bargaining units, the cost-share is a variable rate tied to the employer rate as set forth by CalPERS. The cost-share is subject to a future labor management committee (LMC) pending ratification of successor agreements. This LMC, combined with recent news from CalPERS that its risk mitigation policy would reduce the discount rate, provides an opportunity to inform stakeholders of the mechanics and considerations associated with the cost-share agreements.

**Background pension information**

Due to the number and uncertainty of the calculations involved, defined benefit plans are inherently extremely complex. Several key factors that interact with the cost-share are explained below, but a more comprehensive introduction to pension plan elements was provided during a study session on February 9, 2021 ([link](#)).

*Component pension costs*

Pension costs for agencies which contract with CalPERS are composed of two components, normal cost and unfunded accrued liability (UAL or unfunded liability). The first cost, the normal cost, is the cost for future benefits earned in a given period and is calculated based on current conditions and prospective assumptions about the future. The normal cost is the cost of current service irrespective of past experience except what is used to create future assumptions. The second cost, the unfunded liability, is a cost associated with differences between past expectations and actual experience. As such, unfunded liability is a cost based on already-earned benefits from prior service, irrespective of any employee currently providing service. CalPERS policies include required payments toward unfunded liability such that it will ultimately be extinguished over a multi-year period. As a result, the normal cost is the best indicator of long-run pension costs and the best basis for participants to assess the value of the benefit.

*Pension tiers and employee contribution*

The City has contracted with CalPERS to manage its pension plan for employees since the 1940s. Over the course of that time, several discrete levels of benefit have been provided, with the current range including three tiers based on employment length with CalPERS and hire date with the City. "Classic" employees are those with CalPERS membership dates before January 1, 2013, while employees with membership dates of January 1, 2013 or later are subject to the Public Employee

Pension Reform Act (PEPRA) and referred to as “new” or PEPRA members. Within the “classic” group, benefits differ based on hire date with the City, where those hired prior to the passage of voter ballot initiative Measure L receive a greater benefit, tier 1, than those hired after its passage, tier 2.

For “classic” CalPERS members, the employee contribution is static and set depending on whether the employee is tier 1 classic (receives the 2.7% @ 55 formula for miscellaneous or 3.0% @ 50 formula for safety) or tier 2 classic (receives the 2.0% @ 60 formula for miscellaneous or 3.0 % @ 55 formula for safety). For “new” or PEPRA members (receiving the 2.0% @ 62 formula for miscellaneous or 2.7% @ 57 formula for safety), the employee contribution is a variable rate set at half of the normal cost as calculated by CalPERS.

Table 1 outlines the tiers and membership criteria for all current City plans.

Table 1: City of Menlo Park retirement plans				
Service type	City hire date	CalPERS hire date	Benefit level	CalPERS plan name
Miscellaneous	Before 10/23/2011	Before 10/23/2011	Tier 1	Miscellaneous
	10/23/2011 or after	Before 1/1/2013	Tier 2	
	1/1/2013 or after	1/1/2013 or after	PEPRA	
Sworn safety	Before 11/20/2011	Before 11/20/2011	Tier 1	Tier 1 safety
	11/20/2011 or after	Before 1/1/2013	Tier 2	Tier 2 safety
	1/1/2013 or after	1/1/2013 or after	PEPRA	PEPRA safety

*Cost-share background*

It is important to note the timing of the cost-share adoption because while its implementation is equal across groups but there is a differential impact. The cost-share was implemented prior to the introduction of additional pension tiers and prior to the availability of unfunded liabilities as a discrete cost in the CalPERS valuation reports. One component of the first point is the treatment of employee contribution. At the introduction of the cost-share, employee contributions were fixed but employer contributions were variable, resulting in the City carrying all risk for both normal cost and unfunded liabilities. The PEPRA legislation evenly splits the normal cost between employer and employee for PEPRA members, sharing a substantial portion of overall risk, and all long-term risk, between employer and employee. Employees considered “classic” employees, or those whose membership predates PEPRA, do not have variable rates except in cases where external agreements exist, such as at the City of Menlo Park.

*CalPERS funding risk mitigation policy*

Adopted in 2015, the funding risk mitigation policy directs CalPERS to adjust the discount rate, or assumed rate of return on investments, when it achieves certain returns beyond expectations. CalPERS announced in July of 2021 that the fiscal year 2020-21 returns were sufficient to trigger such a discount rate reduction of 0.2 percent, from 7.0 percent to 6.8 percent, for employers and PEPRA members.

### **Miscellaneous employees**

Under the current agreement language, the cost-share calculation for miscellaneous employees, regardless of bargaining unit, is tied to a threshold employer rate above which the cost is split 50-50 between the City and the employee. This threshold rate was reached in the 2010s and has been adjusted annually based on the CalPERS valuations.

### AFSCME, Confidential, and unrepresented management

The threshold rate for these groups is 15.850 percent and has been calculated using the combined rate for normal and unfunded liabilities as a percentage of estimated payroll. For fiscal year 2021-22, this results in an employer rate of 26.91 percent. As a result, the employee cost-share percentage is 5.53 percent, using the following calculation:

$$\frac{\text{Employer rate} - 15.85\%}{2} = \frac{26.91\% - 15.85\%}{2} = 5.53\%$$

### SEIU

The threshold rate for SEIU is 14.597 percent and the calculation is similar to other miscellaneous groups. The rate for fiscal year 2021-22 is 6.1565 percent using the following calculation:

$$\frac{\text{Employer rate} - 14.597\%}{2} = \frac{26.91\% - 14.597\%}{2} = 6.1565\%$$

### *Expressed cost-share concerns*

Within the miscellaneous group, two major concerns have been raised about the cost-share. The first is that of its variability and the expectation of its gradual rise while the second is the effect of inequity on recruitment and retention.

The first concern relates primarily to the cost-share's ability to functionally reduce or negate a cost-of-living adjustment (COLA) if the CalPERS rate increases. The current cost-share positively impacts the City's total pension costs but also ultimately blunts the purchasing power of employees.

The second concern relates to the differences in benefits earned between tiers. "Classic" formulas are a greater benefit than PEPRA and the employee rate for "classic" members is fixed whereas the PEPRA legislation includes an adjustable employee rate. Based on the current cost-share formula, the total employee contribution as a percentage of the normal cost varies substantially between tiers. With the current cost-share calculation, PEPRA employees are likely to see a total pension cost which exceeds the normal cost of the pension within 2-3 fiscal years whereas "classic" employees are unlikely to experience a similar dynamic. Because "classic" membership is predicated on service date with CalPERS, this has a disproportionate impact on newer and earlier-career employees.

### Miscellaneous employee contribution rates by tier and unit

Table 2 shows the total rates paid by employees toward CalPERS pension costs, as



compared to the normal cost, for fiscal year 2021-22 under the current cost-share language.

**Table 2: Miscellaneous employee contribution rates, fiscal year 2021-22**

Tier and unit	Employee contribution rate	Cost-share rate	Total employee pension contribution rate	Normal cost	Net employee contribution as % of normal
Tier 1 SEIU	8.00%	6.16%	14.16%	21.01%	67.38%
Tier 2 SEIU	7.00%	6.16%	13.16%	17.08%	77.03%
PEPRA SEIU	6.75%	6.16%	12.91%	13.82%	93.39%
Tier 1 AFSCME/Conf/Unrep	8.00%	5.53%	13.53%	21.01%	64.40%
Tier 2 AFSCME/Conf/Unrep	7.00%	5.53%	12.53%	17.08%	73.36%
PEPRA AFSCME/Conf/Unrep	6.75%	5.53%	12.28%	13.82%	88.86%

#### Cost-share trajectory

The assumption changes introduced by CalPERS in December of 2016 included a phase-in or ramp-up period for changes in order to partially shield member organizations from rate volatility but with the resultant effect that rates would continue to rise for a number of years. Unfunded liability rates, displayed as a percentage of anticipated payroll, have risen in recent years and are projected to continue to rise until fiscal year 2027-28. After that time, rates are expected to fall as unfunded liabilities are steadily reduced until being fully eliminated in 2043-44, absent any new unfunded liabilities created as a result of investment earnings not meeting expectations or new assumption changes, including those of implementing the funding risk mitigation policy. Under the language of the current agreements with miscellaneous units, this results in cost-share projections as shown below in Tables 3 and 4 with associated graphical representations. The effects of the discount rate change as a result of fiscal year 2020-21 investment returns has not yet been factored in and will likely not be fully known until summer of 2023 with an impact in fiscal year 2024-25 and beyond.

Table 3: Cost-share projections, AFSCME, confidential, and unrepresented				
Fiscal year	Unfunded liability contribution	Employer normal cost*	Cost-share	Net City rate
2021-22	16.86%	9.55%	-5.53%	20.88%
2022-23	19.02%	9.27%	-6.22%	22.07%
2023-24**	20.33%	9.02%	-6.75%	22.60%
2024-25	21.73%	8.79%	-7.34%	23.19%
2025-26	21.23%	8.56%	-6.97%	22.82%
2026-27	21.83%	8.36%	-7.17%	23.02%
2027-28	21.65%	8.16%	-6.98%	22.83%
2028-29	18.07%	7.95%	-5.09%	20.94%
2029-30	17.90%	7.78%	-4.92%	20.77%
2030-31	17.63%	7.62%	-4.70%	20.55%

\* Blended rate across tiers

\*\* First year the pension becomes a net cost to employment for PEPRAs members

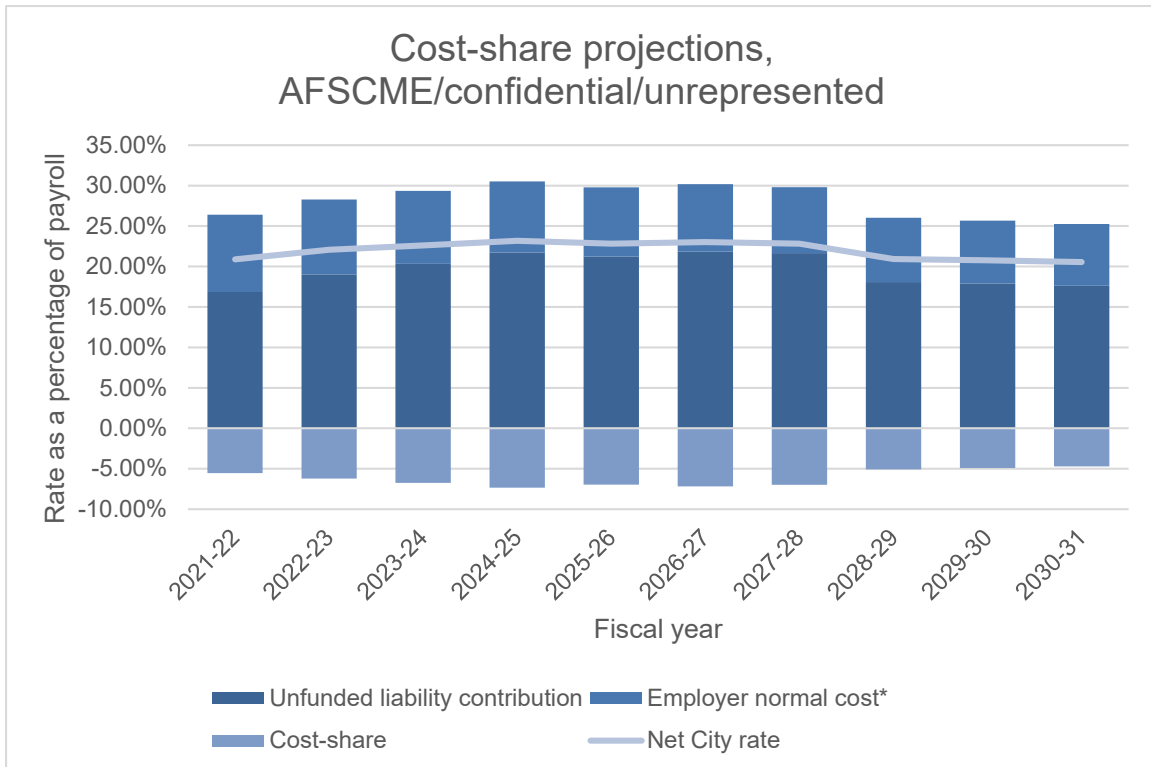
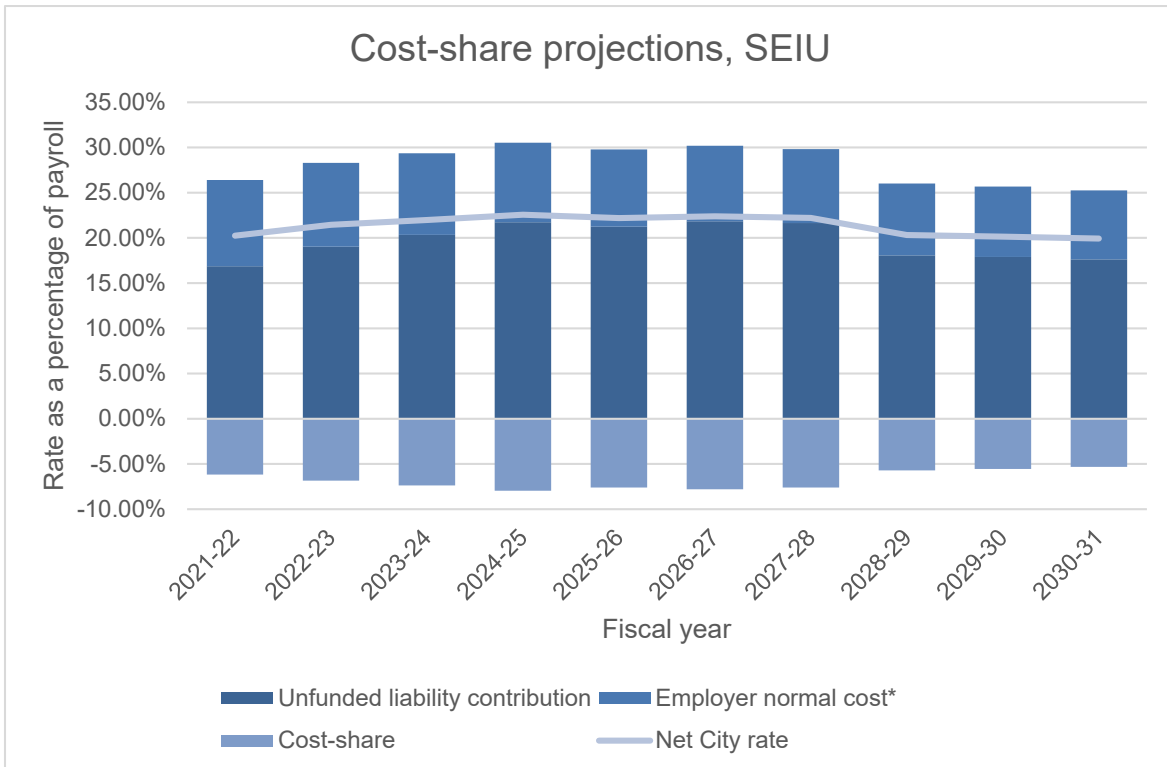

Table 4: Cost-share projections, SEIU				
Fiscal year	Unfunded liability contribution	Employer normal cost*	Cost-share	Net City rate
2021-22	16.86%	9.55%	-6.16%	20.25%
2022-23**	19.02%	9.27%	-6.85%	21.44%
2023-24	20.33%	9.02%	-7.38%	21.97%
2024-25	21.73%	8.79%	-7.96%	22.56%
2025-26	21.23%	8.56%	-7.60%	22.19%
2026-27	21.83%	8.36%	-7.80%	22.39%
2027-28	21.65%	8.16%	-7.61%	22.20%
2028-29	18.07%	7.95%	-5.71%	20.31%
2029-30	17.90%	7.78%	-5.54%	20.14%
2030-31	17.63%	7.62%	-5.33%	19.92%

\* Blended rate across tiers

\*\* First year the pension becomes a net cost to employment for PEPRA members





**RATIFICATION OF TENTATIVE AGREEMENT  
WITH SEIU LOCAL 521 AND AFSCME LOCAL 829**  
City Council Meeting August 17, 2021

ARNEBEAGA FENBY  
GYMNASIUM

## REQUESTED ACTIONS

- Receive presentation by City staff
- Receive public comment
- Consider ratification of successor agreements with SEIU and AFSCME expiring June 30, 2023

## PUBLIC INPUT AND OUTREACH

- Public input and outreach process
  - Early release on January 25, 2021
  - City Council presentation on February 9, 2021
- SEIU Bargaining Unit
  - Contract originally through June 30, 2020 but extended to June 30, 2021
  - July 2020 inflation adjustment of 2.9% deferred to June 20, 2021
  - 74 SEIU classifications
  - Non-Sworn employees throughout the City
- AFSCME Bargaining Unit
  - Contract originally through June 30, 2020 but extended to June 30, 2021
  - July 2020 inflation adjustment of 2.9% deferred to June 20, 2021
  - 22 AFSCME classifications
  - Non-Sworn supervisors throughout the City



# TENTATIVE AGREEMENT



## KEY ECONOMIC PROVISIONS - SEIU

Contract Term	Tentative Agreement	Fiscal Impact
Term	2 Years (expiring June 30, 2023)	(\$30,000)
Wages	3.0% across the board July 1, 2022	\$396,997
Lump Sum	\$2,000 lump sum after ratification 2021 \$2,000 lump sum after July 1, 2022	\$588,050
Cafeteria plan increase	2022 CPI increase between 2-4% 2023 CPI increase between 2-4%	\$148,027
<b>Total</b>	Contract term, compounded	<b>\$809,049</b>



## KEY ECONOMIC PROVISIONS - AFSCME

Contract Term	Tentative Agreement	Fiscal Impact
Term	2 Years (expiring June 30, 2023)	(\$30,000)
Wages	3.0% across the board July 1, 2022	\$146,400
Lump Sum	\$2,000 lump sum after ratification 2021 \$2,000 lump sum after July 1, 2022	\$150,882
Cafeteria Plan increase	2022 CPI increase between 2-4% 2023 CPI increase between 2-4%	\$42,035
<b>Total</b>	Contract term, compounded	<b>\$330,125</b>

## OTHER NEGOTIATED CHANGES

- SEIU AND AFSCME
  - Total compensation survey to be completed by October 31, 2022
  - Safety shoes/boot allowance reimbursement processing period clarified
  - 34 floating holiday hours renewed annually for term
- AFSCME
  - Labor management committee to study impact of additional cost share to inform future negotiations

## FISCAL IMPACT

- Within City Council authority to negotiating team
- Salary and benefits budget certainty for next two fiscal years
- Totals \$1,139,174 over the life of the contracts
- Assumptions
  - Consistent with past financial forecasts
  - In-line with CalPERS actuarial wage growth
  - Fully funded through the 2021-22 budget and incorporated into the long-term financial forecast for future years

## REQUESTED ACTIONS

- Receive presentation by City staff
- Receive public comment
- Consider ratification of successor agreements with SEIU and AFSCME expiring June 30, 2023



# THANK YOU



- SEIU Local 521 Bargaining Team
  - Sheena Castro
  - Keith Dowdell
  - John Murphy
  - Allan Olson
  - Justin Pham
  - Sandra Floyd
  - Zachary Merrill
- AFSCME Local 829 Bargaining Team
  - Whit Loy
  - Rene Morales
  - Jarrod Harden
  - Ashley Mates
- Sloan Sakai Yeung Wong LLP
  - Charles Sakai
  - Scott Kenley
- Administrative Services
  - Nick Pegueros
  - Dan Jacobson
  - Kristen Middleton Strubbe
  - Barbara Tong



**STAFF REPORT**

**City Council**  
**Meeting Date:** 8/17/2021  
**Staff Report Number:** 21-145-CC

**Regular Business:** **Adopt Resolution No. 6649 to ratify a successor agreement between the City of Menlo Park and the American Federation of State, County, and Municipal Employees Local 829 expiring June 30, 2023**

**Recommendation**

Adopt Resolution No. 6649 to ratify a successor agreement between the City of Menlo Park and the American Federation of State, County and Municipal Employees, Local 829 (AFSCME) expiring June 30, 2023.

UPDATE – This report has been updated from the early release version with several edits indicated in red underlined text. Attachment C provides additional background for the Committee for employee cost share reduction (MOU Section 14.8, Page 40.)

**Policy Issues**

City Council retains sole authority to enter into memoranda of understanding with recognized labor units. Memorandum of understanding (MOU) negotiations are governed by the Meyers-Milias-Brown Act (MMBA), Government Code section 3500. MMBA requires that local agencies meet and confer in good faith regarding wages, hours, and other terms and conditions of employment with representatives of recognized collective bargaining units. MMBA further requires that the City fully consider proposals made by collective bargaining unit representatives before determining policy or course of action.

**Background**

City Council held its initial hearing to receive public input before launching negotiations with AFSCME February 9. After the public input hearing, City Council appointed Charles Sakai of Sloan Sakai Yeung Wong LLP to serve as the City's chief negotiator. Mr. Sakai received direction to negotiate the successor MOU with AFSCME, and both parties reached a tentative agreement (Attachment A) June 18.

The previous MOU for non-sworn supervisors, AFSCME, had original terms of October 1, 2017, through June 30, 2020. The MOU was then extended to expire June 30, 2021, and added the California State Disability Insurance (SDI) benefit and modified the long-term disability program to coordinate with SDI. AFSCME agreed to defer their July 2020 inflation-based across-the-board wage increase at the City's request due to the financial uncertainty resulting from the COVID-19 pandemic. Under that agreement,

classifications and employees represented by AFSCME received the deferred July 2020 inflation-based wage increase of 2.9 percent effective June 20, 2021. The MOU between City and AFSCME expired June 30, 2021, so the wage increase that was deferred to June 20, 2021 was within the extended MOU term. Additionally, City past practice honors the terms and intent of expired MOUs until the full ratification of a successor agreement.

**Analysis**

This report summarizes the tentative agreement negotiated in good faith with AFSCME representatives. AFSCME’s membership ratified the tentative agreement June 21. While the tentative agreement conforms to the authority provided to Mr. Sakai in-closed-session, the final action requires City Council ratification at a public meeting. The City Council adopted 2021-22 budget fully funds the tentative agreement provisions.

Attachment A transmits a redline version of the expired MOU to highlight the tentative agreement for City Council ratification. Table 1 summarizes tentative agreement terms with financial impacts.

Table 1: Tentative agreement items with financial impact to City		
Item	Description	Cost/ (savings)
<b>Term</b> MOU Article 24 Page 51	The tentative agreement (TA) provides for a two-year term beginning with City Council ratification and ending June 30, 2023. Given that negotiation of a successor agreement is not required for one fiscal year, the City is estimated to save approximately \$30,000 per year which reflects legal costs and internal staff time required to support negotiations.	(\$30,000)
<b>Pay rates</b> MOU Section 7.1 Page 17	Assuming City Council ratification August 17, 2021, the TA includes an across the board cost of living adjustment to all pay rates in this unit, as follows: <ul style="list-style-type: none"> <li>3% effective the pay period following July 1, 2022</li> </ul>	\$146,400
<b>Lump sum payments</b> MOU Section 7.1.2 Page 17	The TA provides a lump sum payment to all employees in this unit as follows: <ul style="list-style-type: none"> <li>\$2,000 per employee effective the pay period following ratification in 2021</li> <li>\$2,000 per employee effective the pay period following July 1, 2022</li> </ul>	75,441 <u>75,441</u> \$150,882
<b>Flexible benefits plan contribution</b> MOU Section 13.1.2 Page 36	The TA includes an across the board increase in flexible benefits plan contribution based on the annual Consumer Price Index for the San Francisco Bay Area: <ul style="list-style-type: none"> <li>2022 CPI* Increase between 2-4%</li> <li>2023 CPI Increase between 2-4%</li> </ul>	20,808 <u>21,227</u> \$42,035
<b>Total</b>	Year 1 Year 2, incremental Contract term, compounded	\$96,249 \$213,068 \$330,125

\*Consumer price index

Classification and compensation study (MOU Section 7.1.3, Page 17)

The City last completed a classification and compensation study for non-sworn personnel in 2015-16. The 2015-16 study's results informed salary increases for those positions and job families found to be below market median total compensation. Total compensation incorporates the full range of wages and benefits, including pension costs and pension cost-share. The tentative agreement requires the City to retain a survey consultant, similar to the 2015-16 total compensation study. Unlike the 2015-16 study, Section 7.1.3 does not result in salary increases for positions identified as below market. The provision intends to inform negotiations of a successor agreement effective July 1, 2023, alongside the City's financial recovery, including assessed values for the 2021 and 2022 property tax rolls and the status of transient occupancy tax (TOT) revenue.

City staff will request proposals from qualified consultants in the first half of 2022 to meet the deadline of October 31, 2022, for the survey results. The cost is unknown.

Committee for employee cost share reduction (MOU Section 14.8, Page 40)

Menlo Park led the pension reform effort during the Great Recession of the mid-'00s by implementing a cost-share provision the AFSCME MOU (Section 14) beginning July 1, 2011. The cost-share provision requires that employees fully pay their employee cost (~~6.5 percent~~, 7.0 percent, ~~7.3 percent~~, or 8.0 percent, depending on their date of hire) plus 50 percent of the employer's variable cost over 15.850 percent. Active AFSCME employees contribute 5.53 percent in 2021-22 per the terms of Section 14.

The Public Employees' Pension Reform Act (PEPRA) of 2012 structurally modified pension benefits available to new members in the CalPERS system. Effective January 1, 2013, all new members to CalPERS (PEPRA members) are subject to the following reduction in benefit compared to employees grandfathered under the legislation:

1. A required 50/50 cost-share of the total cost retirement benefit (normal cost) earned by the employee in a given year. The PEPRA employee contribution, ~~7.3~~ ~~6.5~~ percent for 2021-22, is above the City's cost-share, and adjusts annually to reflect changes in CalPERS' normal cost assumptions;
2. Full retirement age of 62 and early retirement starting at age 52 with an early retirement penalty;
3. A cap on pensionable wages that adjusts annually, 2021 cap is \$153,671; and
4. Exemption of certain wages and benefits previously included in the pension benefit calculation.

The tentative agreement establishes a venue for management and labor representatives to discuss the complex issue of rising pension costs and the current pension landscape .

**Impact on City Resources**

The City Council adopted budget incorporates the terms of the tentative agreement. The net increase in City costs is \$330,125 over the life of the contract.

**Environmental Review**

This action is not a project within the meaning of the California Environmental Quality Act (CEQA) Guidelines §§ 15378 and 15061(b)(3) as it will not result in any direct or indirect physical change in the environment.



### **Public Notice**

Public notification was achieved by posting the report 15 days prior to the City Council meeting of August 17, 2021.

### **Attachments**

- A. Redlined version – MOU between AFSCME and City of Menlo Park, July 1, 2021 – June 30, 2023
- B. Resolution No. 6649
- C. [Memo: Pension cost-share background and factors; July 9, 2021](#)

Report prepared by:

Barbara Tong, Management Analyst I

Kristen Middleton, Interim Human Resources Manager

Nick Pegueros, Assistant City Manager

**MEMORANDUM OF UNDERSTANDING**  
**BETWEEN**  
**AMERICAN FEDERATION OF**  
**STATE, COUNTY, AND MUNICIPAL EMPLOYEES**  
**LOCAL 829**  
**AND**  
**THE CITY OF MENLO PARK**



~~October 1, 2017 through June 30, 2020~~ July 1, 2021 – June 30, 2023

TABLE OF CONTENTS

	Page
PREAMBLE.....	4
ARTICLE 1: RECOGNITION.....	4
ARTICLE 2: UNION SECURITY.....	5
ARTICLE 3: REPRESENTATION.....	8
ARTICLE 4: DEFINITIONS.....	9
ARTICLE 5: LAYOFF AND RE-EMPLOYMENT.....	9
ARTICLE 6: PERSONNEL ACTIONS.....	12
6.1: Probation.....	12
6.2: Performance Evaluation.....	14
6.3: Performance Improvement Plan.....	14
6.4: Personnel Files.....	14
6.5: Promotional Opportunities.....	15
6.6: Reclassification.....	16
6.7: Recruitment.....	17
6.8: Re-employment – Voluntary Separation.....	17
ARTICLE 7: PAY RATES AND PRACTICES.....	17
7.1: Overall Wage Adjustments.....	17
7.2: Step Increases.....	18
7.3: Application of Rates.....	18
7.4: Effect of Promotion, Demotion or Transfer on Salaries.....	19
7.5: Bilingual Differential.....	19
7.6: Call Back Pay.....	19
7.7: Standby Pay.....	20
7.8: Rest Period Following Extended Work.....	20
7.9 Working Out of Classification.....	21
7.10: Night and Weekend Differential.....	21
7.11: Court Appearances.....	21
7.12: <u>Lump Sum Payments</u>	
7.13: <u>Classification and Compensation Study</u>	
ARTICLE 8: HOURS AND OVERTIME.....	22
ARTICLE 9: UNIFORMS.....	24
ARTICLE 10: HOLIDAYS.....	25
ARTICLE 11: VACATIONS.....	27
ARTICLE 12: LEAVE PROVISIONS.....	28
12.1: Sick Leave.....	28
12.2: Long Term Disability.....	31
12.3: Leave Without Pay.....	31
12.4: Jury Duty and Subpoenas.....	32
12.5: Military Leave.....	32
12.6: Bereavement Leave.....	33
12.7: Maternity and Parental Leave.....	33
12.8: Miscellaneous Leave Provisions.....	33
12.9: Educational Leave and Tuition Reimbursement.....	34
ARTICLE 13: BENEFIT PROGRAMS.....	35
ARTICLE 14: RETIREMENT.....	37
ARTICLE 15: GRIEVANCE PROCEDURE.....	38
ARTICLE 16: EFFECT ON EXISTING PRACTICES.....	44

ARTICLE 17: NONDISCRIMINATION.....	44
ARTICLE 18: MANAGEMENT RIGHTS.....	44
ARTICLE 19: CONCERTED ACTIVITIES.....	45
ARTICLE 20: SEPARABILITY.....	46
ARTICLE 21: DISCIPLINARY ACTION.....	46
ARTICLE 22: TRANSFER.....	47
ARTICLE 23: SAFETY.....	49
ARTICLE 24: TERM OF AGREEMENT.....	49
APPENDIX A: CLASSIFICATIONS	
APPENDIX B: PAY RANGES	
APPENDIX C: LABOR MANAGEMENT COMMITTEE	

## PREAMBLE

This Memorandum of Understanding is entered into by and between American Federation of State, County and Municipal Employees, AFL-CIO (hereinafter "Union") and the City of Menlo Park (hereinafter "City"). This Memorandum of Understanding is entered into pursuant to the Meyers-Miliias-Brown Act (Government Code Sections 3500-3510) and has been jointly prepared by the parties.

## ARTICLE 1: RECOGNITION

- 1.1 The Union is recognized as the exclusive representative of the classifications for City employees as listed in Appendix "A" to this Agreement. Nothing herein shall be construed to discriminate against any individual who chooses to exercise his/her right of self-representation under Section 3502 of the Government Code.
  
- 1.2 Each newly established job classification shall be assigned to an appropriate representation unit by the Human Resources Director, after consultation with recognized employee organizations, if they find that there is an appropriate unit to which such job classifications may be assigned. An employee organization may appeal in writing from such assignment to the Human Resources Director within thirty (30) calendar days of said determination. If the Union is unsatisfied with the results of said appeal, the Union may invoke impasse procedures in accordance with Government Code 3500. In general the City shall adhere to objectives which require that the appropriate unit shall be the broadest feasible grouping of positions that share an identifiable community of interests. Factors to be considered may include:
  - a. Similarity of the general kinds of work performed, types of qualifications required and the general working conditions.
  - b. History of representation in the City and similar employment.
  - c. Consistency with the organizational patterns of the City of Menlo Park.
  - d. Number of employees and classifications, and the effect on the administration of employer-employee relations created by the fragmentation of classifications and proliferation of units.
  - e. Effect on the classification structure and impact on the stability of employer-employee relationship of dividing single or related classifications among two or more units.

- 1.3 The following employees are not eligible for representation by this bargaining unit:
- 1.3.1 All sworn police and sworn police management classifications which are contained in other bargaining units;
  - 1.3.2 Members of the Management Team who are not subject to merit system employment procedures or protection;
  - 1.3.3 Independent contractors.

## ARTICLE 2: UNION SECURITY

### 2.1 Agency Shop

Consistent with the provisions of the California Government Code, Section 3502.5, an employee covered by this agreement shall either: (1) become a member of the Union and pay regular Union dues, or (2) pay to the Union an agency (representation) fee as permitted by law, or (3) present to the Union and the City's Human Resources Director a written declaration that he or she is a member of a bona fide religion, body, or sect that has historically held conscientious objections to joining or financially supporting public employee organizations. An employee who qualifies for this exemption shall, in lieu of the agency fee payment, pay an amount equal to the agency fee to one of the following three (3) non-religious, non-labor, charitable organizations:

- Second Harvest Food Bank of Santa Clara and San Mateo Counties
- Boys & Girls Clubs of the Peninsula
- InnVision Shelter Network

An employee who claims such exemption must submit written proof of such charitable payment annually to the Union and the Human Resources Director. If the employee fails to provide such written proof, the employee will be required to pay the agency fee.

### 2.2 Fee Deduction

If any employee in a classification covered by this MOU fails to authorize one of the above deductions within thirty (30) calendar days of date of hire or within thirty (30) calendar days' notice of the provisions of this agency shop, the City shall deduct the agency fee from the employee's paycheck. The City shall determine the timing of such automatic deductions. The requirement that employees who are not members of the Union pay this representation agency fee shall remain in effect until the earlier of: (1) expiration of this Agreement; (2) termination of the Agency Shop clause by action of the bargaining unit; or (3) legislation invalidating the manner in which Agency Shop was adopted. In the event that employees in the representation unit vote to rescind Agency Shop, the provisions of Section 2.3 – Maintenance of Membership, shall apply to dues-paying members of the Union.

### 2.3 Maintenance of Membership

Any employee who becomes a member of AFSCME shall not revoke such authorization except during the thirty (30) calendar day period between ninety (90) calendar days and sixty (60) calendar days preceding the expiration of this Memorandum of Understanding.

Revocation during said period shall be by written, signed statement furnished to the City with a copy sent to the Union (by the City).

An employee who so withdraws from Union membership shall still be subject to the provisions of Agency Shop (Section 2.1 above).

An employee who is subsequently employed in a position outside of the AFSCME unit shall not be required to continue dues deduction.

## 2.4 Payroll Deduction

2.4.1 The Union may have the regular dues of its members within the representation unit deducted from employees' paychecks under procedures prescribed by the City for such deductions. Dues deductions shall be made only upon signed authorization from the employee upon a form furnished by AFSCME and distributed by the City, and shall continue until: (1) such authorization is revoked, in writing, by the employee pursuant to the provisions of this Section 2.4; or (2) the transfer of the employee out of the representation unit.

2.4.2 The Union shall notify the City at least thirty (30) days in advance of any change in its dues and fees.

2.4.3 Employees may authorize dues deductions only for the organization certified as the recognized employee organization of the unit to which the employees are assigned.

2.4.4 Employees may voluntarily elect to have contributions deducted from their paychecks under procedures prescribed by the District for the P.E.O.P.L.E. fund. Such deductions shall be made only upon signed authorization from the employee and shall continue until such authorization is revoked in writing.

2.4.5 If, after all other involuntary and insurance premium deductions are made in any pay period, the balance is not sufficient to pay the deduction of Union dues, agency fee, or charity fee required by this Section, no such deduction shall be made for the current pay period.

2.4.6 The provisions of Section 2.4.1 above shall not apply during periods that an employee is separated from the representation unit, but shall be reinstated upon the return of the employee to the representation unit. For the purpose of this section, the term separation includes transfer out of the representation unit, layoff, and leave of absence without pay.

## 2.5 Union Obligations

2.5.1 The Union shall provide the City with a copy of the Union's Hudson Procedure for the determination and protest of its agency fees. The Union shall provide a copy of said Hudson Procedure to every agency fee payor covered by this Memorandum of Understanding and annually thereafter, and as a condition to any percentage change in the agency fee.

2.5.2 The Union will supply the City with deduction authorization forms and/or membership applications as well as other informational materials it wishes to be distributed to new employees.

2.5.3 Annually, the Union shall provide the City with copies of the financial report which the Union annually files with the California Public Employee Relations Board, the United States Department of Labor (Form LM-2), or the Union's balance and operating statement for the prior year. Failure to file such a report within sixty (60) days after the end of its fiscal year shall result in the termination of all agency fee deductions without jeopardy to any employee, until such report is filed.

2.5.4 The Union shall refund to the City any amount paid to it in error upon presentation of supporting evidence.

## 2.6 City Obligations

2.6.1 Any new employees hired into positions covered by this Memorandum of Understanding shall be provided by the City and shall execute an "Employee Authorization for Payroll Deduction" form selecting one of the following: (1) Union dues; (2) agency fee; or (3) if he/she qualifies pursuant to the requirements of Section 2.1 above, a fee equal to agency fee payable to one of three (3) negotiated charities.

2.6.2 P.E.O.P.L.E. Checkoff. All employees who choose to do so may request an additional deduction from their paychecks to be forwarded to the Union and accounted for in a separate notation. Such additional deduction shall be used for political campaign purposes and shall be totally voluntary.

2.6.3 All transmittal checks shall be accompanied by documentation which denotes the employee's name, employee ID number, amount of deduction and member or fee payor status.



2.6.4 The City shall hand out agreed upon Union materials along with Agency Shop forms.

2.7 Hold Harmless

The Union shall indemnify, defend, and hold the City harmless against any and all claims, demands, suits, orders, or judgments, or other forms of liability that arise out of or by reason of this Union Security section, or any action taken or not taken by the City under this Section 2. This includes, but is not limited to, the City Attorney's fees and costs.

2.8 Upon request from the Union, but not more than once every six (6) months, the City shall supply the Union with a list of the names, addresses, and classifications of all unit employees except those who file written notice with the Human Resources Department objecting to release of addresses, in which case information will be transmitted without address. Once a month, the City shall supply the Union with a list of representation unit new hires and separations which occurred during the previous month. Additionally, once a month the City shall supply to the Union a list, generated by the City, that includes all represented employees, their Department, division and an indication of their membership status.

2.9 Except in cases of emergency, the Union shall be informed sufficiently in advance in writing by Management before any proposed changes not covered by this Memorandum of Understanding are made in benefits, working conditions, or other terms and conditions of employment which require the meet and confer or meet and consult process.

ARTICLE 3: REPRESENTATION

3.1 It is agreed that, as long as there is no disruption of work, three (3) Union representatives shall be allowed reasonable release time away from their work duties, without loss of pay, to act in representing a unit employee or employees on grievances or matters requiring representation before the City or similar agencies. The Union shall designate the three (3) representatives under this section. Only one (1) representative shall be entitled to release time under this section for any one (1) grievance or group of related grievances. Release time shall be granted for the following types of activities:

3.1.1 A meeting of the representative and an employee or employees in the unit related to a grievance.

3.1.2 A meeting with Management.

3.2 The Union agrees that the representative shall give advance notification to his/her supervisor before leaving the work location except in those cases involving emergencies where advance notice cannot be given. Release time is subject to the legitimate scheduling needs of the department.

3.3 Three (3) Union representatives who are City employees shall be allowed a reasonable amount of time off without loss of pay for formal negotiation purposes. Preparation

time for negotiations shall not be on release time without approval of the Human Resources Director.

- 3.4 Three (3) representatives shall be allocated up to two (2) hours time off every other month without loss of pay for purposes of meeting and consulting on matters within the scope of representation, other than formal negotiations.

#### ARTICLE 4: DEFINITIONS

##### 4.1 Definitions

- 4.1.1 A “temporary” or “contract” employee is an employee employed for a definite term of up to six months, although such temporary employee may be held over for up to three (3) additional months when the temporary employee is filling a vacancy created by leave without pay and the leave is extended beyond the initial fixed period.
- 4.1.2 A “provisional” employee is an employee employed for a definite term of more than six (6) months, although such provisional employee may be held over beyond the initial term of employment as specified in Section 12.4.1. A provisional employee shall be employed and treated in all respects for the entire term of employment as a provisional employee, the same as a probationary employee.
- 4.1.3 A “probationary” employee is an employee who has not yet completed the probationary period, or any extension(s) thereof, as provided in this Agreement. A probationary employee is eligible for benefits provided in this Agreement, except as limited by Sections 6.1.5 and 6.1.8 of this Agreement.
- 4.1.4 A “permanent” employee is an employee who has satisfactorily completed the probationary period, or any extension(s) thereof. A permanent employee is eligible for benefits provided in this Agreement.

#### ARTICLE 5: LAYOFF AND RE-EMPLOYMENT

##### 5.1 Layoff

- 5.1.1 Whenever in the judgment of the City Council it becomes necessary in the interests of economy or because the position no longer exists, the City Council may abolish any position or employment in the competitive service, or may reduce the hours of any position. The decision to abolish a position or reduce the hours of any position shall not be subject to the grievance procedure contained in this Agreement.
- 5.1.2 It is agreed between the parties that attrition is the preferred method of accomplishing any necessary reduction in the work force.

- 5.1.3 If a permanent reduction of hours is proposed for a particular classified position, the incumbent has the right to exercise any and all of the rights set forth in this Article. The incumbent may also choose to be laid off and receive the benefits contained in this Article.
- 5.2 Notification of Layoff
  - 5.2.1 Employees being laid off shall be given written notice from the City's Human Resources Department at least forty-five (45) calendar days prior to the effective dates of layoff. The layoff notice shall contain a statement of the effective date of layoff, a statement of "bumping rights" including the specific positions into which the employee may bump, and a statement of re-employment rights. Notice of layoff shall be given by personal service and the employee shall sign an acknowledgment of personal service; or by certified mail, return receipt, postage prepaid. The Union shall receive concurrent notice of individual layoff notices.
  - 5.2.2 The Union shall be afforded an opportunity to meet with the City to discuss the circumstances requiring the layoff and any proposed alternatives.
- 5.3 Seniority
  - 5.3.1 For the limited purposes of this Article 5, "length of service" means all hours in paid status including holiday, vacation, and paid leave, but does not include any hours compensated for overtime or standby, military leave, unpaid illness, unpaid industrial accident leave, or hours served as a temporary or contract employee in classifications other than the classification in which the employee is being laid off.
  - 5.3.2 In the event an employee reverts to a previously held classification, seniority shall include all time accrued previously in the lower classification, as well as all time accrued in the higher classification.
  - 5.3.3 No seniority credit shall be earned during periods of separation from service with the City, including suspension without pay as a result of disciplinary action.
- 5.4 Order of Layoff
  - 5.4.1 All temporary employees in a particular classification will be laid off before any provisional, probationary or permanent employee in the classification.
  - 5.4.2 All provisional employees in a particular classification will be laid off before any probationary or permanent employee in the classification.
  - 5.4.3 All probationary employees in a particular classification will be laid off before any permanent employee in the classification.
- 5.5 Layoff Procedures

Except as otherwise provided, layoffs will be made in reverse order of seniority. The employees with the least time served in a classification shall be laid off first, with ensuing layoffs occurring in reverse order of length of service in the classification. If two employees have served the same time in the classification, then as between those two employees, the layoff will be based on total time of service with the City. If total time of service with the City is the same, then, as between those two employees, the layoff will be determined by a lottery.

## 5.6 Bumping Rights

- 5.6.1 A permanent employee who is designated for layoff, including an employee on probation following reclassification, transfer, or promotion from a permanent position, may elect, in lieu of layoff, to be reassigned to a position in a lateral or lower related classification within his/her department, or another department, provided that in order to displace the employee with less service the laid off employee must have held permanent status in the classification into which he/she is bumping.
- 5.6.2 When a senior employee chooses to bump into a position in a lateral or lower, related classification, said employee must accept the salary, hours, and working conditions of the position to which return is requested.
- 5.6.3 A bargaining unit employee requesting to bump into a classification as provided herein, must make such request to the Human Resources Director in writing within seven (7) calendar days of his/her receipt of written notice of layoff. Failure to comply with the deadline provided herein shall be deemed a waiver of the bumping rights provided in this Section 5.6.
- 5.6.4 Nothing herein shall preclude bumping between bargaining units.

## 5.7 Re-employment

- 5.7.1 The names of employees laid off shall be placed on a re-employment list in inverse order of seniority for a period of two (2) years from the date of layoff. The employee with the greatest seniority on the re-employment list shall be offered reinstatement when a vacancy occurs in a classification in which the employee held permanent status.
- 5.7.2 A laid off employee may refuse an offer of re-employment to a position for which he/she is qualified, however, refusal of two (2) offers of re-employment to the classification from which laid off shall automatically cause removal of the employee's name from the re-employment list and loss of any re-employment rights.
- 5.7.3 Any employee who accepts an offer of re-employment shall have his/her name removed from the re-employment list.

- 5.7.4 An employee who has been laid off and has been placed on a re-employment list shall be eligible, during the time the employee is on the re-employment list, to take promotional exams.
- 5.7.5 Offers of re-employment shall be made via the U.S. Mail Service, Certified Return Receipt, and shall include the specific position and/or hours being offered, the rate of pay, level of benefits, a current job description, a mechanism for acceptance or refusal of the offer of re-employment within the prescribed time limit, and a place for the laid off employee's signature. Failure to respond within ten (10) days from the date of service of offer of re-employment shall be deemed a refusal of that offer of re-employment.

The Union shall receive concurrent notice of each re-employment offer. Date of service is defined as the date marked on the certified mail return card, or the date the notice is returned by the postal service as undeliverable.

## 5.8 Miscellaneous Provisions

- 5.8.1 For the limited purpose of Article 5, permanent employees, including employees on probation following reclassification, re-employment, reinstatement, transfer, promotion, or demotion from a permanent position who are laid off shall be entitled to one (1) month severance pay and three (3) months of paid health insurance.
- 5.8.2 Employees appointed from a re-employment eligibility list shall have all rights accrued at the time of layoff restored including accrued sick leave, rate of vacation accrual and seniority, but excluding benefits to the extent compensation has been received prior to re-employment. Severance pay, if any, shall not be repaid.

## ARTICLE 6: PERSONNEL ACTIONS

### 6.1 Probation

- 6.1.1 The probationary period shall be regarded as part of the testing process and shall be utilized for closely observing the employee's work, for securing the most effective adjustment of a new employee to a prospective position, and for rejecting any probationary employee whose performance is not satisfactory.
- 6.1.2 During the seventh pay period following employment, the employee shall receive a performance evaluation. Human Resources shall send a reminder notice of this deadline to the appropriate supervisor, with copies to the employee and City Manager.

6.1.3 All original and promotional appointments shall be subject to a probationary period of six (6) months for unit members. The Human Resources Director may, based upon the recommendation of the employee's supervisor, extend the probationary period not to exceed six (6) months if the employee marginally performed the necessary job functions and needs an additional six (6) months to bring performance to a satisfactory level. Total absences lasting four (4) weeks or more shall extend the review period by the corresponding duration of the absence.

6.1.4 At least one month prior to permanent appointment the City shall begin to review the work of the probationary employee to determine the following:

- a. certify him/her for the position;  
or
- b. extend the probation;  
or
- c. reject him/her for the position.

The City shall take action on this determination by the last day of the probation period by notifying the employee in writing. If the notification is delayed by more than five working days following the last day of probation, the employee shall become permanent.

6.1.5 If the service of a probationary employee is unsatisfactory, the employee will be notified in writing that he/she has been rejected for the permanent position. Said notice shall contain the reasons for rejection. The Human Resources Director shall, upon request, afford an interview in a timely fashion to the terminated employee for discussion of the reasons for termination. The employee may, upon request, be accompanied by a Union representative. The interview shall not be deemed a hearing nor shall it obligate the City to reconsider or alter the termination action.

6.1.6 An employee deemed unsatisfactory for a position shall return to his/her prior classification and non-probationary status in that classification and to the pay step he/she would have had if not promoted, transferred or voluntarily demoted.

6.1.7 Departments may not shift job assignments as a reason in itself for placing an employee on probationary status.

6.1.8 The parties agree that probationary employees shall have the same rights as other employees under this Memorandum of Understanding, including full and complete access to the grievance procedure, except that employees who do not hold prior permanent status with the City shall have no right to review any disciplinary action or decision to unfavorably terminate the probation.

Employees who do hold prior permanent status shall have the right to appeal any disciplinary action, but not the decision to unfavorably terminate the probation.

6.1.9 A probationary period begins on the first day of work when the employee is selected to fill a permanent position.

## 6.2 Performance Evaluation

6.2.1 The City may, from time to time, develop reasonable guidelines that enable the supervisor to adequately evaluate the employee as to satisfactory job performance. Job performance reviews shall be conducted pursuant to regularly established and announced policies. The guidelines shall be in accordance with the job specifications for the position being reviewed.

6.2.2 During the term of this MOU, the Union and the City agree to meet and confer over the creation of a pay-for-performance system.

6.2.3 Performance evaluations are not appealable through the grievance procedure but, in the event of disagreement over content, the employee may request a review of the evaluation with the next higher level of Management, in consultation with the Human Resources Director. For purposes of this review, the employee may be represented by the Union. Decisions regarding evaluation appeal shall be made in writing within ten (10) working days following the meeting.

## 6.3 Performance Improvement Plans

When the performance of an employee falls below the minimum standards established for a position, a performance improvement plan may be developed. The employee has the right to have a Union representative present during the development of the performance improvement plan. Performance improvement plans must describe in detail the areas of deficiency, and contain a reasonable plan for improvement.

When used, Performance Improvement Plans shall be an integral extension of the job performance review process, and shall not be used, by themselves, for disciplinary actions.

## 6.4 Personnel Files

6.4.1 The Human Resources Department shall maintain personnel records for each employee in the service of the City showing the name, title of position held, the department to which assigned, salary, changes in employment status, attendance records and such other information as may be considered pertinent. An employee is entitled to review his/her personnel file upon written request or may authorize, in writing, review by his/her Union representatives, with the exception of information obtained confidentially in response to reference inquiries. Upon written request by the employee, an employee or the Union shall be allowed copies of materials in an employee's personnel file relating to a grievance.

6.4.2 The City shall notify an employee and an authorized representative of the Union of any adverse material placed in an employee's personnel file if that material is or has not previously been reviewed with the employee. The employee shall have a reasonable time and opportunity to comment thereon.

6.4.3 In any disciplinary action the City may not rely upon any previous written warnings, notice of suspension or demotion, or written evaluation not contained in said file as justification for any personnel action which adversely affects the employee in question, but may rely on oral warnings not made a part of the file and issued within the preceding six (6) months. In the event an employee who has received written warnings or reprimands has completed twenty-four (24) months of work without further disciplinary action, his/her prior disciplinary record of similar instances, except for sustained findings of violations of the City's Anti-Harassment and Non-Discrimination policy, shall no longer be relied upon in any determination which in any manner affects his/her employment status and shall be removed from the employee's personnel file upon request from the employee. In cases where an employee is suspended or demoted and such discipline is sustained, a record of such action shall be kept in the personnel file and any such documentation supporting such action shall be kept in a separate file in the Human Resources Department.

6.4.4 Personnel files of individual employees are confidential information and shall be used or exhibited only for administrative purposes or in connection with official proceedings before the City Council. The City will only release information to creditors or other persons upon proper identification of the inquirer and acceptable reasons for the inquiry. Information then given from personnel files is limited to verification of employment, length of employment and verification and disclosure of salary range information. Release of more specific information may be authorized in writing.

## 6.5 Promotional Opportunities

6.5.1 Promotional opportunities for classifications within the representation unit will be posted for at least ten (10) working days (Monday through Friday) prior to closing applications. Such postings shall include a description of the type of examination and screening process that will be used in filling the position. Any test given shall relate to the skills, knowledge, and abilities necessary to perform the job. Where an interview panel is used as part of the examination process, at least one member of that panel shall, whenever feasible, be a person who is not employed by the City, but is employed by a different municipality performing or supervising similar duties and responsibilities..

6.5.2 Members of the bargaining unit who are permanent employees applying for promotional opportunities and who meet the minimum qualifications for the position will be considered and interviewed.



6.5.3 In the event a temporary employee is appointed to the position being temporarily occupied for 2,080 hours or more, the total hours worked prior to the date of appointment shall be totaled and divided by the permanent hours per week, and the seniority adjusted to reflect the time served as a temporary employee. The adjusted seniority will be recognized for purposes of seniority, vacation, and salary advancements.

## 6.6 Reclassification

6.6.1 During the term of this Agreement, the City shall notify the employee concerned in case of contemplated change in job content as contained in the classification descriptions which were in effect at the beginning of the Agreement. The Union shall be notified in advance of any contemplated changes in classification descriptions and such changes shall be discussed with the Union, provided that the City shall have the final decision regarding job content. The Union shall be given a reasonable opportunity to meet and confer on the impact of any such changes on matters within the scope of representation.

6.6.2 Once each year, during the month of January, an employee may request in writing a re-evaluation of his/her job based on significant changes in job content or significant discrepancies between job content and the classification description. The request must contain justification. A statement by Management that a job re-evaluation request will be submitted with the departmental budget does not relieve an employee from the responsibility of submitting his/her own request in a timely manner. If meetings are held, the employee may request representation by the Union. The City will process the request and issue a recommendation within ninety (90) days. The City shall not agree to a change in the appropriate pay level for a job description until the Union has received a copy of the proposed change and has been given the opportunity to meet and confer with the City. Reclassifications shall become effective the first pay period of the fiscal year.

If the employee receives a favorable recommendation for reclassification prior to the first pay period of the fiscal year, he or she will receive pay for working out of classification under Section 7.8.

During the term of this Agreement, the Union shall coordinate submission of job re-evaluation requests.

6.6.3 In conducting classification studies, the compensation figure calculated for each City shall consist of the following components: base salary, employer paid employee contributions to the retirement system, and deferred compensation contributions made by the employer on behalf of the employee.

6.6.4 The reclassification procedure shall not be used for the purpose of avoiding use of the promotion or demotion procedures.

6.7 Recruitment

In cases where an employee has vacated an authorized position within the unit, the City shall endeavor to begin the recruitment process within thirty (30) working days.

6.8 Re-employment – Voluntary Separation

Any employee who voluntarily terminates employment and is rehired within twelve months of the date of separation from the City shall have their accrual rates adjusted to the levels achieved prior to separation, except that the time in which the employee was not employed by the City shall not be counted. In addition, all leave balances not paid out upon separation shall be restored to the levels appearing on City records as of the date of separation, except for floating holiday which will not be restored for the remainder of the calendar year in which the separation occurred.

For all other purposes, the time in which the employee was not employed by the City will be treated in the same manner as an unpaid leave of absence.

Re-employment of any employee within the twelve (12) month period is at the sole discretion of the City. If the City decides not to re-employ the former employee, the decision of the City shall be final and not be subject to appeal or to the grievance procedure.

ARTICLE 7: PAY RATES AND PRACTICES

7.1 Overall wage adjustment

7.1.1 ~~Effective the beginning of the first full pay period following the later of July 1, 2022 or City Council adoption, the pay rates for employees in this representation unit shall be increased by an amount equal to three percent (3%). Effective the beginning of the first full pay period after ratification of this Agreement by the membership and approval by City Council, the pay rates for employees in this representation unit shall be increased by four Percent (4.0%). The pay rates for employees in the representation unit shall be as set forth in Appendix “B” to this Agreement.~~

7.1.2 Lump Sum Payments  
Year 1  
Year 1 Payment - AFSCME members who are City employees during the first pay period following the later of City Council adoption of the resolution authorizing amendments to the MOU or July 1, 2021 will receive a one-time lump sum payment of \$2,000. Employees may elect to have the \$2,000 Lump Sum Payment deposited into their Deferred Compensation Account (subject to IRS maximum contribution limits). If the employee does not elect to deposit the Lump Sum Payment into their Deferred Compensation Account or if the money cannot be lawfully deposited, it will be included in the employee’s paycheck for the

applicable pay period. The Parties intend and understand that this lump sum payment is non-pensionable and will not be reported to CalPERS. The parties also agree that this payment is intended to be specific to the pay period in which it is paid and is to be considered part of the regular rate for this pay period only.

#### Year 2

Year 2 Payment – AFSCME members who are City employees during the first pay period following the later of City Council adoption of the resolution authorizing amendments to the MOU or July 1, 2022 will receive a one-time lump sum payment of \$2,000. Employees may elect to have the \$2,000 Lump Sum Payment deposited into their Deferred Compensation Account (subject to IRS maximum contribution limits). If the employee does not elect to deposit the Lump Sum Payment into their Deferred Compensation Account or if the money cannot be lawfully deposited, it will be included in the employee’s paycheck for the applicable pay period. The Parties intend and understand that this lump sum payment is non-pensionable and will not be reported to CalPERS. The parties also agree that this payment is intended to be specific to the pay period in which it is paid and is to be considered part of the regular rate for this pay period only.

#### 7.1.3 Classification and Compensation Study

The parties agree to meet with the City’s retained survey consultant, and review the consultant’s recommended survey jurisdictions, benchmark classifications, and survey matches for a revised Total Compensation Survey to be completed by October 31, 2022. The union will have a minimum of two (2) AFSCME members representatives attending each meeting on release time. Meetings shall begin no later than September 1, 2022 and shall continue on a monthly basis, subject to any agreement to modify the schedule.

The Parties intend the Total Compensation Survey to provide information to support consideration of market-based equity adjustments for individual classifications for successor MOU negotiations. Negotiations will consider both the total compensation survey results and the City’s Financial recovery, including:

- Impact on assessed values for the 2021 and 2022 rolls
- TOT recovery, considering 2019 baseline.

~~Effective the beginning of the first full pay period following July 1, 2018, the pay rates for employees in this representation unit shall be increased by three percent (3.0%). The pay rates for employees in the representation unit shall be as set forth in Appendix “B” to this Agreement.~~

~~7.1.3 Effective the beginning of the first full pay period following July 1, 2019, the pay rates for employees in this representation unit shall be increased by two and one half percent (2.5%). The pay rates for employees in the representation unit shall be as set forth in Appendix “B” to this Agreement.~~

## 7.2 Step Increases

Merit advances from the first salary step to the second salary step shall be granted at six (6) month intervals and between second and subsequent steps at one (1) year intervals if the affected employee has demonstrated continued competent service. Employees who are hired in at Steps B, C or D, or are promoted and placed at Steps B, C or D will be eligible for their next step increase in six (6) months. For the purpose of determining step time requirements, time will commence on the first day of the month coinciding with or following entrance onto a salary step. Step increases shall be effective on the first day of the payroll period in which the time requirements have been met.

During the term of this Agreement, the parties agree to discuss, in an informal manner, alternatives to the merit pay system and related step increases, which may include exploration of various pay for performance systems, as well as ways in which to recognize certificates, advanced degrees and other career achievements. Such discussions may lead to an alternative pay system that would be implemented in lieu of the current system detailed in Sections 7.2 and 7.3 of this Memorandum of Understanding. If both parties agree to such a system during the term of this agreement, the change shall be documented by side letter with the intent of including it in subsequent contracts. Nothing in this section shall commit either party to making a change to the current system during the contract term.

## 7.3 Application of Rates

7.3.1 Employees occupying a position in the competitive service shall be paid a salary or wage within the range established for that position's class under the pay plan as provided. The minimum rate for the class shall normally apply to beginning employees. However, subject to the approval of the Human Resources Director, the department head may hire beginning employees who are especially qualified by their training or by their previous experience at any step in the range.

7.3.2 In the event that a newly hired employee is placed above Step A on the salary schedule due to recruitment problems, as opposed to the conditions in 7.3.1 above, incumbents in that classification who have been placed on a lower step of the salary schedule will be moved to the same step on the salary schedule as the newly hired employee, and all such employees will be allowed to move to the next step in six months.

## 7.4 Effect of Promotion, Demotion or Transfer on Salaries

### 7.4.1 Promotion

Upon promotion, the employee shall be placed on the first step in the new salary range, or on the step which provides for a minimum five percent (5%) increase in salary, whichever is greater, not to exceed the top step of the new range.

7.4.2 Demotion

Upon demotion of an employee with permanent status in his/her current class, his/her salary shall be adjusted to the highest step in the new class not exceeding the salary received in the former class.

7.4.3 Transfer

Upon transfer, the salary shall remain unchanged.

7.5 Bilingual Differential

7.5.1 Employees who are assigned to job duties requiring bilingual skills are eligible to receive Sixty-Five Dollars (\$65.00) each pay period for the use of bilingual skills in job duties arising during the normal course of work.

7.5.2 Eligibility for the bilingual pay differential shall be determined by the Human Resources Director on the basis of a proficiency test determined by the City.

7.5.3 Bilingual skills shall not be a condition of employment except for employees who are hired specifically with that requirement. If an employee is hired under this provision, that requirement shall be included in the initial appointment letter.

7.5.4 The City retains the right to discontinue the bilingual differential for any individual employee when bilingual services are no longer required, provided the City gives the Union ten (10) days notice prior to such revocation, in order to allow the opportunity for the parties to meet and consult.

7.5.5 No employee shall be required to use bilingual skills who is not compensated under this section.

7.6 Call Back Pay

7.6.1 Any employee who is required by the City to report to their normal work location on a day when the employee has not been scheduled, or any employee called back to work after completing their regular work day and leaving their normal work location, shall be entitled to a minimum of two (2) hours of compensation at one and one-half times their hourly rate of pay.

- 7.6.2 Employees who do not return to their normal work location, but who are required to work remotely, are not eligible for call back pay, but shall be paid for time actually worked.
- 7.6.3 Payment for call back may be at the cash rate specified in Section 7.6.1 above or in compensatory time off at the rate of one and one-half hours for each hour worked, at the employee's option. Prior to the end of the pay period, the employee shall designate, on the appropriate City form, his/her choice of either compensation at one and one-half times their hourly rate of pay or compensatory time off.

## 7.7 Standby Pay

- 7.7.1 An employee performing standby duty outside the employee's regular work shift shall be compensated at the rate of Three Dollars and Seventy-Five Cents (\$3.75) per hour for each hour the employee is assigned to standby duty. In the event the SEIU employees' standby rate changes, the City will maintain a fifty cent (\$0.50) differential in the standby hourly rate. An employee shall not combine standby pay with call back pay or overtime.

## 7.8 Rest Period Following Extended Work

- 7.8.1 A Public Works employee shall be entitled to eight (8) hours of rest period when they work more than sixteen (16) hours within a twenty-four (24) hour period beginning with the time the worker reports to work.
- 7.8.2 Prior to working over sixteen (16) hours within a twenty-four (24) hour period and triggering the eight (8) hour rest period the employee must get approval from the Public Works Director or his/her designee.
- 7.8.3 Rest periods are unpaid unless the rest period overlaps the employee's regular work shift in whole or in part. The employee will be paid for that portion of the rest period that overlaps the employee's normal working shift. The employee will be required to work the remainder of their normal working shift that does not overlap with the eight (8) hour rest period unless they request and are approved for leave. The employee will not be paid for the time between expiration of the rest period and his/her normal work shift.
- 7.8.4 This section shall not apply in emergency situations.

## 7.9 Working Out of Classification

- 7.9.1 The term "working out of classification" is defined as a Management authorized assignment to perform work on a temporary basis wherein

significant duties are performed by an employee holding a classification within a lower compensation range. The appropriate Department Director or Designee must approve assignments of Working out of Classification in writing and on a City-authorized form.

The employee must be working in a budgeted position (i.e., the position must be vacant or the incumbent must be on a long term leave of absence and/or vacation). Pay for working out of classification shall be as follows:

7.9.1.1 An employee performing duties associated with a higher position on an out of classification basis will receive acting pay of five percent (5%) for the hours worked in that capacity.

When the Department Head anticipates that the out of classification assignment will be for a period of 240 hours or more, the employee will receive the pay rate of the higher classification beginning with the start of the assignment. If such a determination has not been made by the end of the 240 cumulative hours worked in the higher classification, the employee shall receive the pay rate of the higher classification.

7.9.2 Out of classification provisions do not apply to work assignments performed in connection with declared conditions of public peril and/or disaster.

#### 7.10 Night and Weekend Differential

7.10.1 Employees in the Library assigned to work hours between 5:00 P.M. and 8:00 A.M. weekdays or between Friday from 5:00 P.M. to Monday 8:00 A.M. shall be compensated for night and weekend differential at five percent (5%) above the employee's base pay.

7.10.2 The Communications and Records Manager assigned swing, midnight, relief or day shift on the weekend shall be compensated for night and weekend differential at five percent (5%) above the employee's base pay. Overtime hours shall not be used to qualify for weekend or night shift differential.

#### 7.11 Court Appearances

Employees required to appear in Court during off-duty hours to testify regarding matters arising out of the employee's employment with the City, shall receive a minimum of four (4) hours pay at time and one-half (1.5). The City reserves the right to require the employee to wait to testify at their work location and perform duties as assigned while waiting to testify, provided the Court consents. If the Court requirement expires prior to the expiration of the four (4) hour minimum, the employee shall be released.

This section does not apply in situations where the employee is held over after or called in prior to his or her regular shift as long as the period is adjacent to the normal work shift. In these situations, standard overtime provisions shall apply.

## ARTICLE 8: HOURS AND OVERTIME

### 8.1 Hours of Work

#### 8.1.1 Regular Work Schedules

- a. The regular work schedule for all employees except those on a flexible schedule such as a 4/10, 9/80 or 12 hour schedule, shall consist of forty (40) hours within a seven (7) day work week and is five (5) consecutive days served in units of eight (8) hours. For this schedule, the workweek begins Sunday midnight and ends Saturday at 11:59 P.M.
- b. A 4/10 work schedule shall be four (4) days served in units of ten (10) hours within a seven (7) day work week. For this schedule, the workweek begins Sunday midnight and ends Saturday at 11:59 P.M.
- c. A 9/80 work schedule shall be nine (9) days served in one (1) unit of eight (8) hours and eight (8) units of nine (9) hours over a two week pay period. For this schedule, the workweek shall begin exactly four (4) hours after the start time of the day of the week which is each employee's regular alternate day off.

8.1.2 Part-time Employees. Employees who work less than the regular week and day as set forth above shall be designated as part-time and shall have hours scheduled by the appropriate supervisor and approved by the City's Human Resources Director.

8.1.3 Lunch Periods. All employees working a work shift of six (6) hours or more, shall observe an unpaid lunch period of not less than thirty (30) minutes nor more than sixty (60) minutes. Lunch periods shall be scheduled with the approval of the department head.

8.1.4 Rest Periods. One (1) fifteen (15) minute rest break with pay shall be provided to unit members for each four (4) hours of service. Rest periods and lunch periods may not be aggregated and used to extend the lunch period or shorten the work day as part of a regular schedule.

### 8.2 Overtime

#### 8.2.1 Definition.



- a. Overtime for employees is defined as any time worked in excess of forty (40) paid hours in any seven day work week.

Overtime shall be compensated pursuant to Section 8.2.3. All overtime must be authorized and approved in advance by the Department Head.

8.2.2 Modified Schedules. At the request of either the employee or Department Head, the Department Head may approve a schedule of more than eight (8) hours per day without overtime compensation. Employees shall not be assigned irregular hours to avoid overtime.-Such a work schedule must be consistent with the regular work schedules defined in Section 8.1.1.

8.2.3 Overtime. Overtime may be assigned on a required basis or requested by the employee and approved by the Department Head. Overtime shall be compensated at either (1) the rate of one and one-half (1.5) times the employee's regular rate of pay or (2) in the form of compensatory time at the rate of one and one-half (1.5) hours for each hour worked, as described in Section 8.2.4.

8.2.4 Compensatory Time. An employee may accumulate a maximum of one hundred sixty (160) hours of compensatory time. Compensatory time may be used when the services of an employee are not needed for the efficient functioning of his/her department, and must be approved in advance by the Department Head. Once an employee has reached the limits of compensatory time in this section he/she shall receive cash at the overtime rate for all overtime worked.

Upon termination, all unused compensatory time shall be paid out at the employee's existing rate of pay.

- a. Employees will make an irrevocable election to receive either CTO or pay for all overtime hours worked in the following calendar year. This election will occur once annually, coinciding with the vacation cash-out election period.
  - 1) If an employee fails to file his or her election by the annual deadline established by the City, that employee will receive pay for all overtime hours worked in the following calendar year and no compensatory time may be accrued.
  - 2) Overtime offered as "pay only" (e.g., when the worker's choice of CTO would interfere with a department's ability to recover the cost of the overtime) can only be worked for pay, even if the employee has elected to receive CTO for the year.
  - 3) When an employee's CTO bank is at the cap in Section 8.2.4, he or she may not accrue additional CTO and will be paid for

all overtime, even if he or she has elected to receive CTO for the year.

- 4) Any compensatory hours accumulated in the calendar year over eighty (80) hours will be cashed out in the full pay period including November 1.

### 8.3 Work Schedule

All work schedule and flexible time work schedule arrangements presently in effect shall continue. If the City proposes to change the work schedule of a classification the Union shall be notified at least fifteen (15) working days in advance and given an opportunity to meet and consult over such proposed changes prior to implementation.

## ARTICLE 9: UNIFORMS

- 9.1 The City will provide uniforms, raingear, coveralls or shop coats when necessary for all Public Works, Engineering, and applicable Building and Planning Department employees, consistent with existing practice.

- 9.2 Technical Services Manager(s) shall upon initial appointment be provided required uniforms as determined by the Chief of Police, and thereafter receive Six Hundred Dollars (\$600.00) per year uniform allowance in the amount of \$23.077 per biweekly pay period. If an eligible employee is on unpaid leave for a period of one (1) full pay period or more, the employee will not receive uniform allowance pay for that period.

The City will provide uniform jackets for City Service Employees whose work is primarily outdoors. Jackets that are worn or damaged in the course of work will be routinely replaced by the City. It will be the employee's obligation to replace lost or misplaced jackets.

If any other employee is required to wear a uniform during the life of this Memorandum of Understanding, the City will meet and confer with the Union concerning the establishment of an equitable uniform allowance.

- 9.3 On presentation of appropriate receipts, the City shall reimburse employees who are required by the City to wear safety shoes/boots for up to Two Hundred Eighty-Five Dollars (\$285.00) toward the cost of no more than three (3) pairs of OSHA approved safety shoes/boots per year. Employees in the Public Works Department assigned to the tree crew shall be reimbursed for up to Three Hundred Forty Dollars (\$340.00) toward the cost of no more than three (3) pairs of OSHA approved safety shoes/boots per year. Shoe repair and resoling are reimbursable under this provision. Shoes/boots purchased under this provision are for the use of the employee exclusively. So long as all required documents are submitted, reimbursements will be processed within two (2) pay periods following supervisory approval. Supervisors will approve or deny (with explanation) within 10 days of the submission.

9.4 Employee clothing seriously damaged or destroyed in conjunction with employment duties will be reasonably replaced by the City.

9.5 The City shall reimburse the Fleet Supervisor in the Maintenance Division who, as a condition of employment, is required to provide his or her own tools and equipment. Reimbursement will be made for tools that the employee selects to purchase, or for tools required to be added to the inventory in order to carry out his or her duties. Reimbursement will be made on submission of receipts, but no more than twice per fiscal year. The City shall reimburse a maximum of one thousand dollars (\$1,000.00) per fiscal year. The reimbursement shall be administered in accordance with Maintenance Division policy. Effective July 1, 2016, the City shall reimburse a maximum of one thousand four hundred dollars (\$1,400) per fiscal year.

## ARTICLE 10: HOLIDAYS

### 10.1 Fixed Holidays

Except as otherwise provided, employees within the representation unit shall have the following fixed holidays with pay:

New Year's Day	January 1
Martin Luther King Day	Third Monday in January
Washington's Birthday	Third Monday in February
Memorial Day	Last Monday in May
Independence Day	July 4
Labor Day	First Monday in September
Veterans Day	November 11
Thanksgiving	Fourth Thursday in November
Day after Thanksgiving	Fourth Friday in November
Christmas Eve	December 24
Christmas Day	December 25

10.1.1 In the event that any of the aforementioned days, except December 24, falls on a Sunday, the following Monday shall be considered a holiday. In the event that any of the aforementioned days falls on a Saturday, the preceding Friday shall be considered a holiday. In the event that December 24 falls on a Sunday, then the preceding Friday shall be considered a holiday.

10.1.2 Pay for Fixed Holidays. All full-time employees shall be paid a full day's eight (8) hours pay at their regular straight time base hourly rate for all fixed holidays as defined herein. All part-time workers shall be entitled to holiday leave with pay for the number of hours each holiday based on the number of hours per week such part-time worker is indefinitely assigned to work in the employee's regularly scheduled part-time position.

10.1.3 Work on Fixed Holidays. Any employee required to work on a fixed holiday and in addition to holiday pay shall be compensated at time and

one-half for such work. Work on a fixed holiday beyond the number of hours in the regular shift being worked on the holiday shall be compensated at double time.

- 10.1.4 An employee who is scheduled to work on a designated City holiday, and subsequently calls in sick, the employee shall not receive holiday pay.

## 10.2 Floating Holiday Time

Employees shall annually receive thirty-four (34) floating holiday hours off with pay, credited on the first pay period of the year. Employees hired after the first pay period of the year shall receive a pro-rated amount of floating holiday hours for the remainder of the calendar year.

On a one-time only basis, employees shall receive 4 additional hours of floating holiday time that may be used between September 27, 2017 and October 10, 2017. If these four hours are not used October 10, 2017, the hours will be automatically cashed out on October 20, 2017.

The following conditions will apply to such floating days off:

- 10.2.1 Employees shall request a floating day off in accordance with normal vacation time off request procedure. In cases of conflicting requests for the same day made at the same time, length of service shall govern who receives the day off.
- 10.2.2 Floating days off must be used during or prior to the end of the twenty-sixth (26) pay period of the year in which it was credited or be forfeited.
- 10.2.3 If an employee fails to take a day off as scheduled, the day off so scheduled will be forfeited, unless a mutually agreeable alternative day off is arranged.
- 10.2.4 Any floating day off for employees who work less than full-time or less than a full year shall be prorated on the basis of hours worked as compared to full-time employment.
- 10.2.5 Floating holiday balances remaining at the time of separation will be forfeited. Employees who are laid off shall be permitted to exhaust their floating holiday balance prior to layoff, subject to department head approval, considering the needs of the department, specifically with regard to the employee's assigned duties and the employee's desires.

## ARTICLE 11: VACATIONS

- 11.1 Each employee shall be entitled to an annual paid vacation, accrued as follows:

11.1.1 For full-time employees:

Less than three (3) years of service - 88 hours per year.

Three (3) years of service through five (5) years of service - 104 hours per year.

Six (6) years of service through ten (10) years of service - 136 hours per year.

Eleven (11) years of service through fifteen (15) years of service - 152 hours per year.

Over fifteen (15) years of service - 176 hours per year.

11.1.2 For permanent part-time employees: a proportional equivalent based on the assigned number of hours worked per week as compared to those worked by a full-time employee.

11.2 Maximum Accrual

Vacation may be accrued up to a maximum of three hundred thirty-six (336) hours for full time employees, and a prorated amount for permanent part time employees. After reaching said maximum, the employee must take time off or accrual will be frozen. Upon separation, there will be no payment for hours in excess of the maximum accrual.

11.3 Vacation Scheduling

11.3.1 The department head shall determine the vacation schedule considering the needs of the department, specifically with regard to the employee's assigned duties and the employee's desires. Use of vacation is subject to the advanced approval of the Department Director or designee. Any and all vacation granted pursuant to this Article shall be granted at time or times as will not reduce the number of employees below that which is reasonably necessary for the efficient conduct of the public business of such department, division or work group. Vacation time requested shall not be unreasonably denied.

11.3.1.1 Vacation Scheduling for Personal Business

11.3.1.2 An employee shall be entitled to a maximum of three (3) vacation days per year for personal business. Such leave shall be deducted from accrued vacation or compensatory time.

11.3.1.3 Personal Business is defined as business of urgent and compelling importance which cannot be taken care of outside of normal working hours and which is not covered under other leave provisions of this Memorandum of Understanding or state and federal laws.

11.3.1.4 An employee shall notify the department head two (2) days before taking this leave, unless an emergency exists which prohibits the employee from providing such advance notice.

11.3.1.5 Requests shall be considered in accordance with Section 11.3.1 above.

#### 11.4 Payment on Separation

Accrued vacation time up to the maximums described in Section 11.2 above shall be paid to an employee permanently separated from City service.

#### 11.5 Vacation Cashout

An employee may cash out vacation leave in accordance with the vacation Cashout Policy.

### ARTICLE 12: LEAVE PROVISIONS

#### 12.1 Sick Leave

12.1.1 Accrual Rates. The City shall provide each employee with paid sick leave at the rate of eight hours per month, earned on a biweekly basis and computed as follows:

12.1.1.1 Full-time employees may accrue up to a maximum of one thousand four hundred forty (1,440) hours, and a proportional equivalent for part-time employees.

12.1.2 Use of Sick Leave. Sick leave shall be allowed and used in cases of actual personal sickness or disability, medical or dental treatment, or as authorized for other necessary health reasons. Up to six (6) days per year of sick leave may be used in cases of actual sickness or disability, medical or dental treatment of members of the employee's immediate family.

If an employee is scheduled to work on a designated City holiday, and subsequently calls in sick, the employee shall not receive holiday pay.

12.1.3 Abuse Enforcement. The City shall be obligated to monitor all sick leave use, and shall take appropriate actions to ensure that benefits are paid out only for use as authorized in Section 12.1.2.

12.1.3.1 Any employee who does not have an accrued sick leave balance and who does not otherwise qualify under the provisions of this Article 12, shall not be paid for any day of sick leave called in, whether genuine or not.

- 12.1.3.2 Management has the authority to monitor potential sick leave abuse and patterns of abuse, and when there is a reasonable basis for suspecting such abuse, may require medical verification as a condition for payment of sick leave.
- 12.1.4 Except for urgent and compelling reasons, employees who are not at work due to a non-work related illness or injury should not be contacted during their absence. This Section does not modify the provisions of Section 12.1.3.
- 12.1.5 Compensation for Accumulated Sick Leave.
- 12.1.5.1 Resignation. A resigning employee who has fifteen (15) or more years of continuous service shall receive compensation for up to fifteen percent (15%) of his/her accumulated sick leave balance up to a maximum of five hundred (500) hours. Such compensation shall be based on the employee's rate of pay on his/her last day of paid service to the City.
- 12.1.5.2 Retirement. An employee who retires under PERS from the City may elect to receive cash compensation for fifteen percent (15%) of his or her accumulated sick leave balance, up to a maximum of one thousand three hundred sixty (1,360) hours, based upon the employee's rate of pay on his or her last day of paid service to the City. If the employee was hired by the City prior to October 23, 2011, he or she may alternately convert their sick leave balance, up to a maximum of one thousand three hundred sixty (1,360) hours, to retirement health credits at the rate prescribed in Section 12.1.5.3. Employees may combine any of the above two options.
- 12.1.5.3 An employee with a minimum of five (5) years of continuous service hired by the City prior to October 23, 2011 may elect to convert accumulated sick leave to retirement health credits upon retirement from the City according to the following schedule:
- Five (5) years of service to fifteen (15) years of service: eight (8) hours of sick leave for each retirement health credit, with any remainder being rounded to the next higher credit;
- Fifteen (15) years of service to twenty (20) years of service: six (6) hours of sick leave for each retirement health credit, with any remainder being rounded to the next higher credit;
- Over twenty (20) years of service: three (3) hours of sick leave for each retirement health credit, with any remainder being rounded to the next higher credit.
- 12.1.5.4 Layoff. An employee hired by the City prior to October 23, 2011 may, upon layoff, after the health insurance benefit paid

under Section 5.8.1 has been exhausted, convert up to a maximum of forty-eight (48) hours of the employee's accrued sick leave balance to retirement health credits at the rate prescribed in Section 12.1.5.3. If laid off with fifteen (15) or more years of continuous service, an employee may elect to receive compensation for up to fifteen percent (15%) of his/her accumulated sick leave balance up to a maximum of five hundred (500) hours, and may combine such option with the retirement health credit conversion described in this subsection if hired by the City prior to October 23, 2011, provided he/she has sufficient accumulated sick leave to do so. Under the compensation option, payout shall be based on the employee's rate of pay on his/her last day of paid service to the City.

- 12.1.6 Double Coverage. Employees who qualify for the retirement health credit conversion may elect double coverage at the rate of two (2) units for every month of paid health insurance.
- 12.1.7 Family Coverage. Employees who qualify for the retirement health credit conversion may elect family coverage at the rate of three (3) units for every month of paid health insurance.
- 12.1.8 Dental Coverage. Employees who qualify for the retirement health credit conversion may elect dental coverage at the rate of one-half (.5) unit for every month of paid dental insurance.
- 12.1.9 Transfer of Sick Leave for Catastrophic Illness. Transfer of sick leave for catastrophic illness is designed to assist employee who have exhausted sick leave due to a catastrophic illness, injury or condition of the employee. This policy allows other employees to make voluntary grants of time to that employee so that he/she can remain in a paid status for a longer period of time, thus partially ameliorating the financial impact of the illness, injury or condition.

A catastrophic illness is defined as an illness which has been diagnosed by a competent physician, requiring an extended period of treatment or recuperation, and which has a significant risk to life or life expectancy. Confirmation of the condition and prognosis by a health care provider chosen by the City may be required.

The Human Resources Department will discuss with AFSCME or their designated representative an appropriate method of soliciting contributions from coworkers. The contributions shall be submitted to Human Resources and Human Resources will process the contribution list in the order established. Any employee shall be allowed to contribute a maximum of eighty (80) hours of sick leave from their accrued sick leave balance to another full-time or permanent part-time employee in the City who is suffering from a catastrophic illness and has exhausted his or her own sick leave, provided, however, they have maintained a positive sick leave



balance of forty (40) hours or more following the donation. Once the contribution is made it cannot be rescinded.

Upon return to work, an employee may bank any remaining hours that have been contributed up to a maximum of forty (40) hours. If the contribution list has not been exhausted, the contributing employees will be notified that their contribution was not required and the balance restored.

## 12.2 Long Term Disability

12.2.1 Should any illness or injury extend beyond forty-five calendar (45) days, the City will ensure continued payment to the employee at 66.67 percent of salary, up to a maximum as provided in the long-term disability policy. The amounts paid shall be less any payments received from either Workers' Compensation or retirement. During the first year of disability and so long as no retirement determination has been made by the City, the employee will be entitled to continued City paid health insurance, AD&D, dental, vision and life insurance benefits providing that the employee continues to pay the employee share of the benefit cost, where applicable. Accrued leave earned shall only continue for periods during which the employee is utilizing accrued leave time.

12.2.2 Employees who have a sufficient amount of sick leave time may, at the employee's option, use sick leave on an hour-for-hour basis to delay the start of the long term disability plan. The long term disability plan would start upon the exhaustion of sick leave. The City procedures which allow for follow-up of an employee who has been out on an extended disability shall apply to employees under this section.

## 12.3 Leave Without Pay

12.3.1 Leaves of absence without pay may be granted in cases of personal emergency or when such absences would not be contrary to the best interest of the City.

12.3.2 Requests for leaves of absence without pay must be written and submitted to the department head and Human Resources Director. The Human Resources Director may grant a permanent employee leave of absence without pay for a period not to exceed one (1) year, during which time no benefits and no seniority credit will accrue. Approval shall be in writing and a copy filed with Human Resources. Upon expiration of a regularly approved leave, or within five (5) working days after notice to return to duty, the employee shall be reinstated in the position held at the time the leave was granted. Failure on the part of an employee on leave to report promptly at its expiration, or within three (3) working days after notice to report to duty, may be deemed notice of resignation and/or cause for disciplinary action.

12.3.3 Vacancies created as a result of leave without pay may be filled in the following manner:

- a) By temporary employees for a maximum of six (6) months;
- b) By provisional employees.

If a leave is extended beyond the initial fixed period, temporary employees may be held over for up to three (3) months (for a total term of employment of nine (9) months) in a temporary capacity. Provisional employees may be held over if a leave is extended, or, in cases where the position is vacated, for the duration of the recruitment period.

#### 12.4 Jury Duty and Subpoenas

12.4.1 An employee required to report for jury duty or to answer a subpoena as a witness on behalf of the City, provided the witness has no financial interest in the outcome of the case, shall be granted a leave of absence with pay from his/her assigned duties until released by the court, provided the employee remits to the City all fees received from such duties other than mileage or subsistence allowances within thirty (30) days from the termination of jury service.

12.4.2 This leave of absence with pay shall extend to employees' whose regular shift is a shift outside of the hours of 8:00 A.M. to 5:00 P.M., so that such employees shall not be required to work their regular shift on a day in which they perform jury duty or respond to a subpoena.

12.4.3 When an employee returns to complete a regular shift following time served on jury duty or as a witness, such time falling within work shift shall be considered as time worked for purposes of shift completion and overtime computation. In determining whether or not an employee shall return to his/her regular shift following performance of the duties above, reasonable consideration shall be given to such factors as travel time and a period of rest.

#### 12.5 Military Leave

Military leave of absence shall be granted and compensated in accordance with all applicable laws. Employees entitled to military leave shall give the appointing power an opportunity, within the limits of military regulations, to determine when such leave shall be taken.

#### 12.6 Bereavement Leave

An employee shall be allowed regular pay for not more than 24 hours (or a prorated amount for permanent part time employees) when absent because a death has occurred in the immediate family. For purpose of bereavement leave, members of the immediate family shall be limited to mother, stepmother, father, stepfather, mother-in-law, father-in-law, grandmother or grandfather of the employee, or spouse,

brother, stepbrother, sister, stepsister, child, grandchild, domestic partner or dependent of the employee.

To qualify for bereavement leave in the event of the death of a domestic partner, the employee must have filed a declaration of domestic partnership with the Human Resources Department prior to the request to utilize such leave.

Employees may use other appropriate leave for bereavement purposes for relations not included above provided such leave is approved in advance by the Department Director.

## 12.7 Maternity and Parental Leave

Employees are entitled to leaves of absence for maternity, parental bonding, and pregnancy-related disability. All such leaves of absence shall be granted and compensated in accordance with state and federal laws covering these topics, including the California Family Rights Act.

## 12.8 Miscellaneous Leave Provisions

12.8.1 Leaves of absence without pay which exceed four (4) weeks and are for leaves other than military shall not be included in determining seniority.

12.8.2 At the conclusion of a leave of absence an employee shall be returned to an equivalent position within his/her classification.

12.8.3 For any unpaid leave of absence the employee may elect to continue insurance coverage for up to the duration of his/her leave of absence at his/her own expense.

12.8.4 For any paid leave of absence, all benefits continue to accrue.

12.8.5 The Human Resources Director or designee will designate the specific beginning and ending dates to meet the needs of the employee and the City, which shall not be less than four weeks nor exceed one unpaid year.

12.8.6 At the conclusion of a leave of absence for any disability the employee may be required to submit a physician's statement certifying that he/she is medically qualified to resume work.

12.8.7 All provisions of this Article shall be administered in conformance with all Federal and State Laws.

## 12.9 Educational Leave and Tuition Reimbursement

12.9.1 The City shall contribute Four Thousand Dollars (\$4,000.00) annually on July 1st of each year to the AFSCME educational leave and tuition reimbursement fund. The City will reimburse expenses for tuition, books, lab fees and equipment, and curriculum fees incurred by an

employee, for classes completed in accredited institutions of learning or approved specialized training groups leading to an academic degree or improved job related skills. Parking fees or health fees related to enrollment will not be included. Programs must be approved in advance. Reimbursement will be provided upon successful completion of approved courses. Employees must attach a final grade of “C” or better for both undergraduate and graduate work. The employee may not elect to take a “pass-fail” grade if the letter system of grading is offered. Courses providing a “pass/fail” must achieve a “pass” to qualify for reimbursement. Funds expended on tuition reimbursement will be subject to appropriate IRS regulations. Employees wishing to engage in educational programs involving work time may be granted rescheduled time if departmental operations permit.

- 12.9.3 All employees assigned by the City to attend meetings, workshops, or conventions shall have their dues and reasonable expenses paid by the City and shall be allowed to attend such workshops, meeting and conventions on paid City time. Such required educational functions shall be reimbursed from departmental training funds and shall not be counted against the employee’s allowance or the annual tuition reimbursement.

Employees may under the tuition reimbursement fund request reimbursement for trade publications, technical books, and printed materials related to the employee’s employment.

- 12.9.4 Claims for qualified expenditures shall first be reimbursed to an individual maximum of seven hundred dollars (\$700) per fiscal year. After payment of all such claims, on June 30, should there be unused funds remaining in this fund, qualified claims in excess of seven hundred dollars (\$700) already paid, and received no later than July 15 of that year, shall be reimbursed on a pro-rata basis not to exceed a total annual individual reimbursement of Two Thousand Five Hundred Dollars (\$2,500).

## ARTICLE 13: BENEFIT PROGRAMS

### 13.1 Medical

- 13.1.1 The City shall make a direct contribution equal to the minimum employer contribution for agencies participating in the Public Employees Medical and Hospital Care Act (PEMHCA) on behalf of each active employee and qualified retiree.

~~13.1.2~~

13.1.2 The City shall continue to make a non-elective employer contribution to the flexible benefits plan on behalf of each active employee in an amount which, together with the minimum PEMHCA contribution in 13.1.1 equals the following:

\$2,351 per month - family coverage

\$1,811 per month - two-person coverage

\$961 per month - single coverage

[EXAMPLE: If the PEMHCA minimum contribution is \$140, then the City shall make a flexible benefits plan contribution of \$2,211 per month for family coverage, \$1,671 per month for two-person coverage and \$821 per month for single coverage.]

Cash-in-Lieu of Medical Coverage: Employees who waive coverage will be entitled to \$367.00 per month. Effective January 1, 2018, this amount is no longer contributed through the flexible benefits plan.

13.1.3 For the plan year beginning January 1, 2022, the City shall make a nonelective employer contribution to the flexible benefits plan on behalf of each active employee in an amount which, together with the minimum PEMHCA contribution in 13.1.1 equals the contributions in Section 13.1.2 increased by an amount equal to the twelve-month increase in the consumer price index (CPI-U San Francisco-Oakland-San Jose) measured from February 2020 to February 2021. However, the increase in the City's contribution shall be no less than two percent (2.0%) and no more than four percent (4.0%) (i.e., CPI 2-4%).

13.1.4 For the plan year beginning January 1, 2023, the City shall make a nonelective employer contribution to the flexible benefits plan on behalf of each active employee in an amount which, together with the minimum PEMHCA contribution in 13.1.1 equals the contributions in Section 13.1.3 increased by an amount equal to the twelve-month increase in the consumer price index (CPI-U San Francisco-Oakland-San Jose) measured from February 2021 to February 2022. However, the increase in the City's contribution shall be no less than two percent (2.0%) and no more than four percent (4.0%) (i.e., CPI 2-4%).

13.1.5 In the event that the City's contributions towards medical premiums are less than the Kaiser rate at each level of participation (single, two party, or family) for either plan year 2022 or plan year 2023, the parties will meet and confer in an attempt to address the differences between the City contribution and the Kaiser premium

The City shall continue to make a non-elective employer contribution to the flexible benefits plan on behalf of each active employee in an amount which, together with the minimum PEMHCA contribution in 13.1.1 equals the following:

~~————— \$2,212 per month ————— family coverage~~

~~————— \$1,665 per month ————— two-person coverage~~

~~————— \$839 per month ————— single coverage~~

~~————— [EXAMPLE: If the PEMHCA minimum contribution is \$128, then the City shall make a flexible benefits plan contribution of \$2,084 per month for family coverage, \$1,537 per month for two person coverage and \$711 per month for single coverage.]~~

~~————— Cash in Lieu of Medical Coverage: Employees who waive coverage will be entitled to \$367.00 per month. Effective January 1, 2018, this amount with no longer be contributed through the flexible benefits plan.~~

~~13.1.3 — For the plan year beginning January 1, 2019, the City shall make a non-elective employer contribution to the flexible benefits plan on behalf of each active employee in an amount which, together with the minimum PEMHCA contribution in 13.1.1 equals the following:~~

~~————— \$2,262 per month ————— family coverage~~

~~————— \$1,715 per month ————— two-person coverage~~

~~————— \$889 per month ————— single coverage~~

~~————— Cash in Lieu of Medical Coverage: Employees who waive coverage will be entitled to \$367 per month.~~

~~13.1.4 — For the plan year beginning January 1, 2020, the City shall make a non-elective employer contribution to the flexible benefits plan on behalf of each active employee in an amount which, together with the minimum PEMHCA contribution in 13.1.2 equals the following:~~

~~————— \$2,312 per month ————— family coverage~~

~~————— \$1,765 per month ————— two-person coverage~~

~~————— \$939 per month ————— single coverage~~

~~Cash in Lieu of Medical Coverage: Employees who waive coverage will be entitled to \$367.00 per month.~~

13.1.65 Each Active employee may use his/her allocated amount for any benefits permitted by law and provided for in the FSA plan document. The plan document will be amended to eliminate cash distributions, and to add employee-paid “buy up” of vision benefits.

13.1.76 Employees who have at least ten (10) continuous years of permanent service with the City and who retire under PERS shall be reimbursed by the City at the rate of one hundred dollars (\$100.00) per month toward the retiree’s employee only health care premium once the employee has exhausted the sick leave conversion to retiree health credits under Section

12.1.5.3. This reimbursement shall be in addition to the minimum employer contribution for agencies participating in the Public Employees' Medical and Hospital Care Act (PEMHCA). This section shall not apply to employees hired in a permanent classified position in this unit after October 23, 2009.

13.1.~~87~~ For part-time employees who are a member of the unit, the City shall prorate the dollar amount allocated under Sections 13.1.2, 13.1.3, and 13.1.4.

13.1.~~98~~ Employees whose medical insurance premium costs exceed the combined allocation available through the cafeteria plan and Section 13.1.1 shall have the excess cost of their medical premiums paid with before-tax compensation through a premium conversion plan.

13.1.~~10-9~~ Each employee must enroll in an available PEMHCA health insurance plan or demonstrate that he/she has health insurance coverage equivalent to the PEMHCA plan in order to receive the monthly amount for waiving coverage.

13.1.1~~10~~ Employees who wish to have domestic partners covered under the cafeteria plan may do so after filing the "Declaration of Domestic Partnership" form with the California Secretary of State and complying with any other requirements necessary to qualify for domestic partner health benefits under the PEMHCA health plans. It is understood that the premiums and benefits provided as a result of covering domestic partners may be taxable, and that the City will administer the program in accordance with State and Federal Tax regulations.

13.1.1~~21~~ The parties share an interest in addressing the increase in the cost of PEMHCA benefits. The City shall meet and confer with the Union prior to contracting with an alternative provider, consortia or group. However, the Union will have the option to remain in the PEMHCA program.

13.1.1~~32~~ Effective July 1, 2017, Cash-in-Lieu of Medical Coverage amounts will be included in the calculation of a regular rate for overtime purposes. In the event that a court issues a final decision holding that Cash-in-Lieu of Medical coverage payments do not need to be included in the regular rate, the City will cease including Cash-in-Lieu in the regular rate.

## 13.2 Dental

13.2.1 The City shall pay the full cost for Dental Insurance administered by Delta Dental or an equivalent third party administrator up to the annual maximums described in the summary plan description.

13.2.2 Dental benefits will be provided as described in the summary plan description.

13.3 Vision

The City shall continue to pay the full cost for fully insured Vision Insurance provided by VSP, or an equivalent insurance provider, providing vision benefits as described in the summary plan description.

13.4 Employee Assistance Program

The City shall continue to provide an employee assistance program to employees as currently provided.

13.5 Life Insurance

The City will provide to all employees life insurance at the rate of 1-1/2 times each employee's regular yearly wage.

ARTICLE 14: RETIREMENT

14.1 Retirement benefits for employees hired by the City prior to October 23, 2011, shall be those established by the California Public Employees' Retirement System (CalPERS) for local miscellaneous members 2.7% at age 55 formula, single highest year.

14.2 Retirement benefits for new employees hired by the City on or after February 12, 2012, who are not new members as defined by CalPERS, shall be those established by the California Public Employees' Retirement System (CalPERS) for local miscellaneous members 2.0% at age 60 formula, highest three years.

14.3 For new employees, as defined by CalPERS, hired on or after January 1, 2013, retirement benefits shall be those established by the California Public Employees' Retirement System (CalPERS) for Miscellaneous Members 2.0% at age 62 formula, highest three years.

14.4 The City shall pay none of the employee's contribution to CalPERS. The full unit member's contribution shall be deducted from the unit member's pay by the City and forwarded to CalPERS in accordance with the rules and regulations governing such contributions.

14.5 The City will continue to apply Internal Revenue Code 414 (h)(2) on the employee's contribution to CalPERS.

14.6 Beginning with fiscal year 2011-12, should the employer rate rise above 15.850%, the increase shall be shared equally between the employee and the employer. As an example, if the employer rate for 2011-12 is 16.000%, the City shall pay 15.925% and the employee shall pay 8.075% (inclusive of the 8.000% fixed employee contribution).



- 14.7 Effective as soon as practicable and after January 1, 2014, the employee contribution towards the employer's contribution to the Public Employees' Retirement System (CalPERS) shall be taken as a pre-tax deduction from the employees' paycheck each payroll period. The City and the Union agree that the employee contribution towards the employer's contribution will continue past the expiration of the MOU. If for any reason the City is precluded from making this deduction or the deduction cannot be made on a pre-tax basis, the parties agree to meet and confer regarding ways to cure the defect.

14.8 Committee for Employee Cost Share Reduction

The City and AFSCME will establish a labor management committee no later than 180 days prior to the expiration of the contract to study in good faith the impact of the additional cost share in section 14 of AFSCME MOU. AFSCME and the City will each appoint two (2) members to the committee, with additional members to be added by mutual agreement. The Parties intend the committee to inform negotiations over potential modification of the Cost Share as part of a successor MOU.

ARTICLE 15: GRIEVANCE PROCEDURE

15.1 Definitions

- 15.1.1 A grievance is an alleged violation, misinterpretation, or misapplication of the provisions of this Memorandum of Understanding, policy and/or procedure manuals affecting the working conditions of the employees covered by this Agreement
- 15.1.2 A "Disciplinary appeal" is an appeal from a disciplinary action of a Letter of Reprimand or higher, against an employee covered by this Memorandum of Understanding.
- 15.1.3 A "grievant" is any employee adversely affected by an alleged violation of the specific provision of this Memorandum, or the Union.
- 15.1.4 A "day" is any day in which the City Hall of Menlo Park is open for business.
- 15.1.5 The "immediate supervisor" is the lowest level administrator who has been designated to adjust grievances and who has immediate jurisdiction over the grievant.

15.2 General Provisions

- 15.2.1 Every effort will be made by the parties to settle grievances at the lowest possible level.
- 15.2.2 All documents dealing with the processing of a grievance shall be filed separately from the personnel files of the participants.

- 15.2.3 No party to a grievance shall take any reprisals against the other party to the grievance because the party participated in an orderly manner in the grievance procedure.
- 15.2.4 Failure of the grievant to adhere to the time deadlines shall mean that the grievance is settled. The grievant and the City may extend any time deadline by mutual agreement.
- 15.2.5 Every effort will be made to schedule meetings for the processing of grievances at times which will not interfere with the regular work day of the participants.
- 15.2.6 Either the City or the Grievant may be represented at any step of the grievance procedure by an individual of the party's choice.
- 15.2.7 Any employee may at any time present grievances to the City and have such grievances adjusted without the intervention of the Union, as long as the adjustment is reached prior to advisory arbitration and is not inconsistent with the terms of this Memorandum; provided that the City shall not agree to a resolution of the grievance until the Union has received a copy of the grievance and the proposed resolution and has been given the opportunity to file a response. Upon request of the grievant, the grievant may be represented at any stage of the grievance procedure by a representative of the Union.
- 15.2.8 Failure of a unit member to file a grievance over an adverse action which constitutes a "grievance" as defined herein shall not constitute a waiver of other unit members' rights to file future grievances involving the same or similar adverse actions.
- 15.2.9 The City and Union may agree to consolidate grievances at Level II and beyond.

15.3 Grievance Procedure (for grievances as defined in 15.1.1)

Grievances will be processed in accordance with the following procedures.

15.3.1 Level I - Immediate Supervisor

- 15.3.1.1 Any employee who believes he/she has a grievance shall present the grievance orally to the immediate supervisor within ten (10) days after the grievant knew, or reasonably should have known, of the circumstances which form the basis for the grievance. Failure to do so will render the grievance null and void. The immediate supervisor shall hold discussions and attempt to resolve the matter within ten (10) days after the presentation of the grievance. It is the intent of this informal meeting that at

least one (1) personal conference be held between the aggrieved employee and the immediate supervisor.

15.3.2 Level II - Department Director

15.3.2.1 If the grievance is not resolved at Level I and the grievant wishes to press the matter, the grievant shall present the grievance in writing on the appropriate form to the Department Director within ten (10) days after the oral decision of the immediate supervisor. The written information shall include:

- a) a description of the specific grounds of the grievance including names, dates, and places necessary for a complete understanding of the grievance;
- b) a listing of the provisions of this Memorandum which are alleged to have been violated;
- c) a listing of the reasons why the immediate supervisor's proposed resolution of the problem is unacceptable; and
- d) a listing of specific actions requested by the grievant of the City which will remedy the grievance.

15.3.2.2 The Department Director or designee shall communicate the decision to the grievant in writing within ten (10) days after receipt of the grievance. If the Department Director or designee does not respond within the time limits, the grievant may appeal to the next level.

15.3.2.3 With the concurrence of the City, an employee or the Union may choose to file the formal grievance initially at Level II (the Department Director) instead of Level I.

15.3.2.4 Within the above time limits either party may request a personal conference.

15.3.3 Level III - Appeal to City Manager

15.3.3.1 If the grievant is not satisfied with the decision at Level II, the grievant may, within ten (10) days of the receipt of the decision at Level II, appeal the decision to the City Manager. The statement shall include a copy of the original grievance, all decisions rendered and a clear and concise statement of the reasons for the appeal.

15.3.3.2 The City Manager or designee shall respond to the grievance in writing within ten (10) days of receipt of the written appeal.

#### 15.3.4 Level IV - Arbitration

- 15.3.4.1 If the grievant is not satisfied with the decision at Level III, the grievant may within five (5) days of the receipt of the decision submit a request in writing to the Union for arbitration of the dispute. Within fifteen (15) days of the grievant's receipt of the decision at Level III, the Union shall inform the City of its intent as to whether or not the grievance will be arbitrated. The Union and the City shall attempt to agree upon an arbitrator. If no agreement can be reached, they shall request that the State Mediation and Conciliation Service supply a panel of five (5) names of persons experienced in hearing grievances involving City employees and who are members of the National Academy of Arbitrators (NAA). Each party shall alternately strike a name until only one (1) name remains. The remaining panel member shall be the arbitrator. The order of striking shall be determined by lot.
- 15.3.4.2 If either the City or the Union so requests, a separate arbitrator shall be selected to hear the merits of any issue raised regarding the arbitrability of a grievance. No hearing on the merits of the grievance will be conducted until the issue of arbitrability has been decided. The process to be used in selecting an arbitrator shall be as set forth in 15.3.4.1.
- 15.3.4.3 The arbitrator shall, as soon as possible, hear evidence and render a decision on the issue or issues submitted to him/her. If the parties cannot agree upon a submission agreement, the arbitrator shall determine the issues by referring to the written grievance and the answers thereto at each step.
- 15.3.4.4 The City and the Union agree that the jurisdiction and authority of the arbitrator so selected and the opinions the arbitrator expresses will be confined exclusively to the interpretation of the express provision or provisions of this Memorandum at issue between the parties. The arbitrator shall have no authority to add to, subtract from, alter, amend, or modify any provisions of this Memorandum or impose any limitations or obligations not specifically provided for under the terms of this Memorandum. The arbitrator shall be without power or authority to make any decision that requires the City or the administration to do an act prohibited by law.
- 15.3.4.5 After a hearing and after both parties have had an opportunity to make written arguments, the arbitrator shall submit in writing to all parties his/her findings and award.
- 15.3.4.6 The arbitrator shall make a final and binding determination.

15.3.4.7 The fees and expenses of the arbitrator shall be shared equally by the City and the Union (including the cost of any list of arbitrators requested pursuant to Section 15.3.4.1). All other expenses shall be borne by the party incurring them, and neither party shall be responsible for the expense of witnesses called by the other. Either party may request a certified court reporter to record the entire arbitration hearing. The cost of the services of such court reporter shall be paid by the party requesting the reporter or shared by the parties if they both mutually agree. If the arbitrator requests a court reporter, then the costs shall be shared by both parties.

#### 15.4 Disciplinary Appeals

- 15.4.1 A “disciplinary appeal” is a formal written appeal of a Notice of Disciplinary Action (post-Skelly) of any punitive disciplinary action including dismissal, demotion, suspension, reduction in salary, letters of reprimand, or transfer for purposes of punishment. However, letters of reprimand are not subject to the arbitration provisions of this procedure. This procedure also shall not apply to the rejection or termination of at will employees, including those in probationary status. Any reduction in pay for change in assignment which occurs in the course of regular rotation and is not punitive shall not be subject to this procedure.
- 15.4.2 Persons on probationary status (entry-level or promotional) may not appeal under this agreement rejection on probation.
- 15.4.3 Letters of Reprimand may be appealed under this section only to the City Manager level (Section 15.4.4.)
- 15.4.4 Any appeal to any punitive disciplinary action (as defined in Section 15.1.2) shall be presented in writing to the City Manager within ten (10) days after receipt of the Notice of Disciplinary Action. Failure to do so will be deemed a waiver of any appeal. The City Manager or designee shall hold a meeting to hear the appeal within ten (10) days after the presentation of the appeal and shall issue a decision on the appeal within ten (10) days after the presentation of the appeal. For letters of reprimand, the City Manager’s decision shall be final. However the employee may write a response and have that response included in his or her personnel file.
- 15.4.5 For appeals of dismissal, demotion, suspension, or reduction in salary, if the employee is not satisfied with the decision of the City Manager, the employee may, within ten (10) days of the receipt of the decision, submit a request in writing to the Union for arbitration of the dispute. Within twenty (20) days of the City Manager’s decision, the Union shall inform the City of its intent as to whether or not the disciplinary matter will be arbitrated. The Union must be the party taking the matter to arbitration.

- 15.4.6 The parties shall attempt to agree to the selection of an arbitrator and may agree to strike names from a list provided by an outside agency such as the State Mediation and Conciliation Service. However, in the event that the City and the Union cannot agree upon the selection of an arbitrator within forty-five (45) days from the date that the Union has notified the City of its intent to proceed to Arbitration, either party may request a list of five (5) labor arbitrators who shall be retired judges of the Superior Court of the County of San Mateo. The Union and City shall attempt to agree to the selection of a retired judge. If no agreement can be reached, each party shall alternately strike a name from the list until one (1) name remains, who shall serve as the arbitrator.
- 15.4.7 The City and Union agree that the arbitrator shall prepare a written decision containing findings of fact, determinations of issues and a disposition either affirming, modifying or overruling the disciplinary action being appealed. The parties expressly agree that the arbitrator may only order as remedies those personnel actions which the City may lawfully impose.
- 15.4.8 The fees and expenses of the arbitrator (including the cost of any list of arbitrators) shall be shared equally by the City and Union. All other expenses shall be borne by the party incurring them, and neither party shall be responsible for the expense of witnesses called by the other. Either party may request a certified court reporter to record the entire arbitration hearing. By mutual agreement, the cost of the services of such court reporter shall be shared equally by the parties. However, each party shall be responsible for the cost of transcripts that they order.
- 15.4.9 Nothing herein constitutes a waiver of City or employee rights otherwise granted by law.

## ARTICLE 16: EFFECT ON EXISTING PRACTICES

### 16.1 Changes in Personnel Rules and Department Regulations

During the term of this Memorandum of Understanding, the parties hereto will meet and confer regarding changes proposed by the City in the City's Personnel Rules and Department Rules and Regulations.

### 16.2 Effect of Agreement

This Agreement completely supersedes any prior agreements between the parties. It also supersedes any conflicting provision in the City's Personnel Rules.

### 16.3 Existing Practices

Existing practices and/or benefits which are not referenced in this Memorandum and which are subject to the meet and confer process shall continue without change unless modified subject to the meet and confer process.

#### 16.4 Waiver Clause

Except as provided in Section 16.3, Existing Practices, the employees waive their right to meet and confer during the term of this Agreement on any matter raised during the meeting and conferring which preceded this Agreement.

### ARTICLE 17: NONDISCRIMINATION

17.1 The parties agree that they, and each of them, shall not discriminate against any employee on the basis of race, religion, color, creed, age, marital status, national origin, ancestry, sex, sexual orientation, medical condition or disability. The parties further agree that this Section shall not be subject to the Grievance Procedure provided in this Agreement.

17.2 The parties agree that they, and each of them, shall not discriminate against any employee because of membership or lack of membership in the Union, or because of any authorized activity on behalf of the Union. The parties further agree that this Section may be subject to the Grievance Procedure provided in this Agreement.

### ARTICLE 18: MANAGEMENT RIGHTS

18.1 Except to the extent that the rights are specifically limited by the provisions of this Agreement, the City retains all rights, powers, and authority granted to it or which it has pursuant to any law, including, but not limited to the rights to:

- Direct the work force;
- Increase, decrease or re-assign the work force;
- Hire, promote, demote; discharge or discipline for cause;
- Transfer or reclassify employees;
- Assign employees days of work, shifts, overtime and special work requirements, and
- Determine the necessity, merits, mission and organization of any service or activity of the City or of any City Department, Agency or Unit.

18.2 The City has the sole and absolute right to determine the nature and type of, assign, reassign, revoke assignments of or withdraw assignments of, City equipment, including motor vehicles, to or from employees during, after or before hours of duty; to determine the methods, means and numbers and kinds of personnel by which City operations are to be conducted, including the right to contract or subcontract bargaining unit work provided that the City will meet and confer in advance on the impact of subcontracting on work load and safety and any other matter within the scope of representation.

18.3 The exercise of the foregoing powers, rights, authority, duties, and responsibilities by the City, the adoption of policies, rules, regulations and practices in furtherance thereof, and the use of judgment and discretion in connection therewith shall be

limited only by the specific and express terms of this Memorandum and then only to the extent such specific and express terms hereof are in conformance with the Constitution and laws of the United States and the Constitution and laws of the State of California.

- 18.4 The exercise by the City through its Council and management representatives of its rights hereunder shall not in any way, directly or indirectly, be subject to any grievance procedure nor subject to meeting and conferring.

#### ARTICLE 19: CONCERTED ACTIVITIES

- 19.1 As used in this Article 19, “strike or work stoppage” means the concerted failure to report for duty, the willful absence from one’s position, the stoppage of work, or the abstinence in whole or in part from the full, faithful performance of the duties of employment for the purpose of inducing, influencing or coercing a change in the conditions of compensation, or the rights, privileges or obligations of employment.
- 19.2 It is agreed and understood that there will be no strike, work stoppage, slowdown, or refusal to fully and faithfully perform job functions with responsibilities, or any interference with the operations of the City, or any concerted effort designed to improve its bargaining position which interferes with, impedes, or impairs City operations by the Union or by its officers, agents or members. The Union agrees that neither the Union nor its officers, agents or members will, in any manner whatsoever, honor, assist or participate in any picketing activities, sanctions or any other form of interference with City operations by any other non-unit employees or members of other employee associations or groups.
- 19.3 Furthermore, the Union agrees that the provisions in this Article 19 are enforceable by the City in a Court of law. The City may, upon its own election, initiate such court action as it deems appropriate to enjoin or impose damages on the Union, its officers, agents or members for activities referred to herein.
- 19.4 It is further agreed and understood that neither the Union nor its officers, agents, or members shall engage in any boycott, picketing or any other concerted attempts to discourage, impair or negatively affect the businesses of members of the City Council.
- 19.5 Nothing herein shall be deemed to limit the remedies available to the City in dealing with concerted activities as described hereinabove.

#### ARTICLE 20: SEPARABILITY

If any provision of this Agreement shall be declared void or unenforceable by a court of competent jurisdiction, the remaining provisions of this Agreement shall remain in full force and effect, except that either party to the Agreement may request the other party to meet and confer in regard to amending the Agreement to replace the provisions declared void or



unenforceable. However, there will be no obligation on either party to agree on a replacement provision.

## ARTICLE 21: DISCIPLINARY ACTION

- 21.1 For just cause, the City has the right to discipline, demote, or discharge permanent employees for unsatisfactory work or conduct. Disciplinary action, if taken must be acted upon within forty-five (45) days of the date of discovery of the basis for the discipline unless the City demonstrates that at the end of the forty-five (45) day period, it was engaged in an active, ongoing investigation of the allegations.
- 21.2 Non-probationary employees whose work or conduct is unsatisfactory but not sufficiently deficient to warrant discipline, demotion, or discharge will be given a written notification of unsatisfactory work or conduct and an opportunity to improve. Failure to correct deficiencies and improve to meet standards may result in discipline, demotion or discharge. Reprimands shall not be subject to the arbitration provisions of Article 15, Disciplinary Appeals.
- 21.3 Notice of disciplinary action must be in writing and served on the employee and their authorized Union representative in person or by certified and regular mail prior to the disciplinary action becoming effective. The notice must be filed on a timely basis with the Human Resources Department and included in the employee's personnel file. The notice of disciplinary action shall include:
- 21.3.1 Statement of the nature of the disciplinary action;
  - 21.3.2 Effective date of the action;
  - 21.3.3 Statement of the reasons for the proposed action;
  - 21.3.4 Statement in ordinary and concise language of the act or the omissions upon which the reasons for the proposed disciplinary action are based.
  - 21.3.5 In all cases of disciplinary action, the notice shall include a statement advising the employee of his/her right to appeal such action and the right to Union representation.
- 21.4 In cases of demotion, discharge, or suspension of employees in permanent status, the notice of intended discipline shall include a statement of the employee's right to respond, either orally, at a meeting requested by the employee, or in writing. The opportunity to respond shall be afforded prior to the action becoming effective, but the employee must respond no later than five (5) days after receipt of notice of intended disciplinary action. A conference, if requested, shall be scheduled and held as soon as possible but in no event later than thirty (30) days after receipt of notice of intended disciplinary action.
- 21.5 Nothing herein shall prohibit the Union from discussing the issue of a time limit on the duration in which the disciplinary action will remain in the employee's personnel

file, however, by entering into such discussions, there shall be no commitment on the part of the City to agree to a time limit.

## ARTICLE 22: TRANSFER

### 22.1 Definition

For purposes of this Article, a “transfer” shall consist of a change in work location of an employee from one work site to another work site within the City. Such a transfer does not encompass the process of assignment of a specific position and responsibilities within the department or work location. An employee assigned to more than one work site shall be considered as being transferred only when moved from one City-wide program to another program. A transfer may be initiated by an employee (“voluntary”) or by the City (“administrative”).

### 22.2 Voluntary Transfers as a Result of Posting and Filling Vacancies

- 22.2.1 A “vacancy” is a new position, an opening arising from a resignation, retirement, or termination, any position to which an employee is not assigned or which is not committed for purposes of leaves, unresolved administrative transfers or layoffs.
- 22.2.2 Notices of vacancies shall be posted for at least five (5) working days on the bulletin board in the City’s administrative offices. Such notices shall be posted as soon as the City determines that a vacancy exists and shall include the position description, location, and other special requirements. A copy of the vacancy notice shall be forwarded to the Union President and a second copy shall be forwarded to the Union office.
- 22.2.3 The request for transfer will be sent to the Human Resources Director with a copy to the Department Director. A conference shall be held at the request of the employee or the Human Resources Director in order to discuss the request.
- 22.2.4 For purposes of selection between two or more employees requesting transfer to a vacant position, the City shall consider the training experience, competencies, length of service in the City, past evaluations, and qualifications of each employee.
- 22.2.5 When the City has considered two or more employees requesting a transfer to a vacant position to be relatively equal on the basis of training, experience, competence, past evaluations, and qualifications, the employee with the most City-wide seniority shall be selected for transfer to the vacant position.
- 22.2.6 The City shall notify the employee requesting transfer, in writing, of the City’s acceptance or denial of the request. The City shall provide written reasons for not granting the transfer request upon the request of the

employee. Transfer requests shall be acted upon prior to filling positions by promotion or outside applicants.

22.2.7 Only one (1) voluntary transfer may be granted per employee in any one (1) year period.

### 22.3 Administrative Transfers

22.3.1 An administrative transfer may be initiated by the Human Resources Director or his/her designee and shall be based exclusively on the work related special needs of the City and/or welfare of the employees involved and will not be for punitive or capricious reasons.

22.3.2 In the event that circumstances require that an employee be transferred on an administrative basis, the employee and the Union shall be informed of the reason(s) in writing prior to such action and shall be afforded an opportunity to meet with the Human Resources Director regarding the proposed transfer.

22.3.3 For purposes of selecting which employee shall be administratively transferred in order to meet the needs of the City, the City shall consider the training, experience, competencies, length of service in the City, past evaluations, qualifications, and current classification of each employee considered. All things being relatively equal, the employee with the least City-wide seniority will be transferred.

22.3.4 If total time of service with the City for two (2) or more employees considered equal is the same, then, as between those employees, the transfer will be determined by a lottery.

### 22.4 Length of Service Defined

22.4.1 For the purpose of this Article, "length of service" means all hours in paid status including holiday, vacation, and paid leave, but does not include any hours compensated for overtime or standby, military leave, unpaid illness, unpaid industrial accident leave, or hours served as a temporary or contract employee in a classification other than the classification from which the employee is being transferred.

22.4.2 No seniority credit shall be earned during periods of separation from service with the City, including suspension without pay as a result of disciplinary action.

## ARTICLE 23: SAFETY

23.1 It is the City's intention to provide the safest possible equipment and working conditions to the workforce of the City of Menlo Park. Toward that end, the City is committed to making the necessary expenditures to purchase this equipment.

23.2 The Union and the City agree to continue to participate in the City Safety Committee.

ARTICLE 24: TERM OF AGREEMENT

This Agreement shall remain in full force and effect up to and including June 30, 202~~30~~, and thereafter shall continue in effect year by year unless one of the parties notifies the other in writing no earlier than ninety (90) days prior to the expiration or subsequent contract anniversary and no later than sixty (60) days prior to the expiration or subsequent contract anniversary, of its request to modify, amend, or terminate the Agreement. If the parties enter into subsequent meeting and conferring regarding a successor agreement, the terms and conditions of this Agreement shall remain in effect until a successor Agreement is reached, or until meeting and conferring is concluded.

In order to comply with City policy, tentative agreements must be posted 15 days in advance.

The terms of this Agreement shall be effective upon the adoption of this Agreement by the City Council except as otherwise provided by specific sections of this Agreement.

Dated: \_\_\_\_\_

City of Menlo Park

Local 829, A.F.S.C.M.E., AFL-CIO

\_\_\_\_\_

\_\_\_\_\_

\_\_\_\_\_

\_\_\_\_\_

APPENDIX "A"  
CLASSIFICATIONS REPRESENTED BY  
AMERICAN FEDERATION OF STATE, COUNTY AND MUNICIPAL EMPLOYEES,  
LOCAL 829, AFL-CIO

Business Manager  
Communications and Records Manager  
Custodial Services Supervisor  
Information Technology Supervisor  
Literacy Program Manager  
Management Analyst II  
Permit Manager  
Principal Planner  
Public Works Supervisor – City Arborist  
Public Works Supervisor – Facilities  
Public Works Supervisor – Fleet  
Public Works Supervisor – Parks  
Public Works Supervisor – Streets  
Recreation Coordinator  
Recreation Supervisor  
Revenue and Claims Manager  
Senior Accountant  
Senior Building Inspector  
Senior Civil Engineer  
Senior Librarian  
Senior Transportation Engineer  
Water System Supervisor



## APPENDIX "C"

### Menlo Park Labor Management Committee (LMC)

#### GOAL

The Union and Management have a sincere desire to maintain and improve their progressive, mature and cooperative labor relations/personnel relationship throughout the length of the contract.

#### MEETINGS

In order to facilitate this, the parties agree to meet as necessary to discuss work and personnel/labor relations related issues of interest to either the employees or management. These meetings shall not replace informal grievance meetings nor the responsibilities of the parties to meet and confer pursuant to the law and the agreement. However topics may include preliminary discussions of matters which may later develop into more formal concerns to be dealt with in official forums.

#### PARTICULARS

In attendance will be representatives from the City of Menlo Park, as determined by the issues to be discussed. A Union staff person and three members selected by the union shall represent the employees. Additional department heads, members or consultants may be included as necessary.

Agenda shall be set in advance and mutually agreed to except that there shall be a regular item for either party to confirm or dispel rumors in labor relations/personnel topics since the last meeting.

Additional meetings may be set with mutual agreement.

Minutes shall be taken with each side alternately taking responsibility for taking and reproducing them. Confidential personal issues shall be discussed off the record and summarized in the minutes.

#### CALPERS LABOR MANAGEMENT COMMITTEE (CLMC)

Effective for the term of this agreement, the City and Union agree to the establishment of a CalPERS Labor Management Committee (CLMC) to serve as an advisory committee and to facilitate employee education and involvement in issues regarding CalPERS retirement benefits, including but not limited to, potential future costs increases and the impacts of said cost increases to the financial stability of the City.

The City and the Union shall each select their own representatives and in equal number, with no more than three (3) on each side. Each side is encouraged to propose issues for discussion, and the committee will jointly set priorities. Decision making within this forum will be by consensus. The CLMC will set up regular meetings to occur not less than once per quarter and a means for calling additional meetings to handle issues on an ad hoc basis.

The CLMC is not authorized to meet and confer or create contractual obligations nor are they to change the MOU to authorize any practice in conflict with existing contracts or rules.

#### DISABILITY INSURANCE LABOR MANAGEMENT COMMITTEE (DI-LMC)

Effective for the term of this agreement, the City and union agree to the establishment of a Labor Management Committee to explore the possibility of enhancing disability insurance benefits.

The City and the Union shall each select their own representatives and in equal number, with nor more than three (3) on each side. The DI-LMC is not authorized to meet and confer or create contractual obligations nor are they to change the MOU to authorize any practice in conflict with existing contracts or rules.

The City and Union will consider recommendations of the DI-LMC and will meet and confer over those recommendations, but neither will be under any obligation with regard to DI-LMC's recommendations.



**RESOLUTION NO. 6649**

**RESOLUTION OF THE CITY COUNCIL OF THE CITY OF MENLO PARK  
APPROVING AND ADOPTING THE COMPREHENSIVE MEMORANDUM OF  
UNDERSTANDING WITH AMERICAN FEDERATION OF STATE, COUNTY,  
AND MUNICIPAL EMPLOYEES LOCAL 829 WITH A TERM OF JULY 1, 2021  
THROUGH JUNE 30, 2023**

WHEREAS, the City of Menlo Park received a report on expiring labor agreements on February 9, 2021 in accordance with City Council's policy on Public Input and Outreach Regarding Labor Negotiations; and

WHEREAS, the Memorandum of Understanding ("MOU") between the City of Menlo Park ("City") and the American Federation of State, County, and Municipal Employees Local 829 ("AFSCME") expired on June 30, 2021; and

WHEREAS, Negotiators for City and AFSCME began the meet and confer process on March 25, 2021, and met four times before reaching tentative agreement (TA) on a successor MOU on June 18, 2021; and

WHEREAS, City and the AFSCME have met and conferred in good faith and have agreed to the attached comprehensive successor MOU (Exhibit A); and

WHEREAS, the terms of the successor MOU make changes to the wages, flexible benefit plan contributions, and one-time lump sum payments in 2021 and 2022 and has a term July 1, 2021 through June 30, 2023; and

WHEREAS, AFSCME membership ratified the TA set forth in Exhibit A on June 21, 2021; and

NOW THEREFORE, THE CITY COUNCIL OF THE CITY OF MENLO PARK HEREBY RESOLVES THAT:

1. City ratifies the TA with AFSCME for a successor MOU with a term of July 1, 2021 through June 30, 2023, as set forth in Exhibit A attached and incorporated by reference.
2. City Council authorizes the city manager to execute the successor MOU.
3. City Manager may approve formatting edits to the successor MOU.

I, Judi A. Herren, City Clerk of Menlo Park, do hereby certify that the above and foregoing City Council Resolution was duly and regularly passed and adopted at a meeting by said City Council on the seventeenth day of August, 2021, by the following votes:

//

//

//

//

//

AYES:

NOES:

ABSENT:

ABSTAIN:

IN WITNESS WHEREOF, I have hereunto set my hand and affixed the Official Seal of said City on this seventeenth day of August, 2021.

---

Judi A. Herren, City Clerk

**MEMORANDUM**

**Date:** 7/9/2021  
**To:** Nick Pegueros, Assistant City Manager  
**From:** Dan Jacobson, Assistant Administrative Services Director  
**Re:** Pension cost-share background and factors

The City currently uses a cost-share with employees to defray total costs of providing pension benefits through the California Public Employee Retirement System (CalPERS), with a variety of differences between tiers and category of employee, whether miscellaneous or safety, as well as between bargaining groups. Under the terms currently included in the memoranda of understanding (MOUs) between the City and its bargaining units, the cost-share is a variable rate tied to the employer rate as set forth by CalPERS. The cost-share is subject to a future labor management committee (LMC) pending ratification of successor agreements. This LMC, combined with recent news from CalPERS that its risk mitigation policy would reduce the discount rate, provides an opportunity to inform stakeholders of the mechanics and considerations associated with the cost-share agreements.

**Background pension information**

Due to the number and uncertainty of the calculations involved, defined benefit plans are inherently extremely complex. Several key factors that interact with the cost-share are explained below, but a more comprehensive introduction to pension plan elements was provided during a study session on February 9, 2021 ([link](#)).

*Component pension costs*

Pension costs for agencies which contract with CalPERS are composed of two components, normal cost and unfunded accrued liability (UAL or unfunded liability). The first cost, the normal cost, is the cost for future benefits earned in a given period and is calculated based on current conditions and prospective assumptions about the future. The normal cost is the cost of current service irrespective of past experience except what is used to create future assumptions. The second cost, the unfunded liability, is a cost associated with differences between past expectations and actual experience. As such, unfunded liability is a cost based on already-earned benefits from prior service, irrespective of any employee currently providing service. CalPERS policies include required payments toward unfunded liability such that it will ultimately be extinguished over a multi-year period. As a result, the normal cost is the best indicator of long-run pension costs and the best basis for participants to assess the value of the benefit.

*Pension tiers and employee contribution*

The City has contracted with CalPERS to manage its pension plan for employees since the 1940s. Over the course of that time, several discrete levels of benefit have been provided, with the current range including three tiers based on employment length with CalPERS and hire date with the City. "Classic" employees are those with CalPERS membership dates before January 1, 2013, while employees with membership dates of January 1, 2013 or later are subject to the Public Employee

Pension Reform Act (PEPRA) and referred to as “new” or PEPRA members. Within the “classic” group, benefits differ based on hire date with the City, where those hired prior to the passage of voter ballot initiative Measure L receive a greater benefit, tier 1, than those hired after its passage, tier 2.

For “classic” CalPERS members, the employee contribution is static and set depending on whether the employee is tier 1 classic (receives the 2.7% @ 55 formula for miscellaneous or 3.0% @ 50 formula for safety) or tier 2 classic (receives the 2.0% @ 60 formula for miscellaneous or 3.0 % @ 55 formula for safety). For “new” or PEPRA members (receiving the 2.0% @ 62 formula for miscellaneous or 2.7% @ 57 formula for safety), the employee contribution is a variable rate set at half of the normal cost as calculated by CalPERS.

Table 1 outlines the tiers and membership criteria for all current City plans.

Table 1: City of Menlo Park retirement plans				
Service type	City hire date	CalPERS hire date	Benefit level	CalPERS plan name
Miscellaneous	Before 10/23/2011	Before 10/23/2011	Tier 1	Miscellaneous
	10/23/2011 or after	Before 1/1/2013	Tier 2	
	1/1/2013 or after	1/1/2013 or after	PEPRA	
Sworn safety	Before 11/20/2011	Before 11/20/2011	Tier 1	Tier 1 safety
	11/20/2011 or after	Before 1/1/2013	Tier 2	Tier 2 safety
	1/1/2013 or after	1/1/2013 or after	PEPRA	PEPRA safety

*Cost-share background*

It is important to note the timing of the cost-share adoption because while its implementation is equal across groups but there is a differential impact. The cost-share was implemented prior to the introduction of additional pension tiers and prior to the availability of unfunded liabilities as a discrete cost in the CalPERS valuation reports. One component of the first point is the treatment of employee contribution. At the introduction of the cost-share, employee contributions were fixed but employer contributions were variable, resulting in the City carrying all risk for both normal cost and unfunded liabilities. The PEPRA legislation evenly splits the normal cost between employer and employee for PEPRA members, sharing a substantial portion of overall risk, and all long-term risk, between employer and employee. Employees considered “classic” employees, or those whose membership predates PEPRA, do not have variable rates except in cases where external agreements exist, such as at the City of Menlo Park.

*CalPERS funding risk mitigation policy*

Adopted in 2015, the funding risk mitigation policy directs CalPERS to adjust the discount rate, or assumed rate of return on investments, when it achieves certain returns beyond expectations. CalPERS announced in July of 2021 that the fiscal year 2020-21 returns were sufficient to trigger such a discount rate reduction of 0.2 percent, from 7.0 percent to 6.8 percent, for employers and PEPRA members.

### **Miscellaneous employees**

Under the current agreement language, the cost-share calculation for miscellaneous employees, regardless of bargaining unit, is tied to a threshold employer rate above which the cost is split 50-50 between the City and the employee. This threshold rate was reached in the 2010s and has been adjusted annually based on the CalPERS valuations.

### AFSCME, Confidential, and unrepresented management

The threshold rate for these groups is 15.850 percent and has been calculated using the combined rate for normal and unfunded liabilities as a percentage of estimated payroll. For fiscal year 2021-22, this results in an employer rate of 26.91 percent. As a result, the employee cost-share percentage is 5.53 percent, using the following calculation:

$$\frac{\text{Employer rate} - 15.85\%}{2} = \frac{26.91\% - 15.85\%}{2} = 5.53\%$$

### SEIU

The threshold rate for SEIU is 14.597 percent and the calculation is similar to other miscellaneous groups. The rate for fiscal year 2021-22 is 6.1565 percent using the following calculation:

$$\frac{\text{Employer rate} - 14.597\%}{2} = \frac{26.91\% - 14.597\%}{2} = 6.1565\%$$

### *Expressed cost-share concerns*

Within the miscellaneous group, two major concerns have been raised about the cost-share. The first is that of its variability and the expectation of its gradual rise while the second is the effect of inequity on recruitment and retention.

The first concern relates primarily to the cost-share's ability to functionally reduce or negate a cost-of-living adjustment (COLA) if the CalPERS rate increases. The current cost-share positively impacts the City's total pension costs but also ultimately blunts the purchasing power of employees.

The second concern relates to the differences in benefits earned between tiers. "Classic" formulas are a greater benefit than PEPRA and the employee rate for "classic" members is fixed whereas the PEPRA legislation includes an adjustable employee rate. Based on the current cost-share formula, the total employee contribution as a percentage of the normal cost varies substantially between tiers. With the current cost-share calculation, PEPRA employees are likely to see a total pension cost which exceeds the normal cost of the pension within 2-3 fiscal years whereas "classic" employees are unlikely to experience a similar dynamic. Because "classic" membership is predicated on service date with CalPERS, this has a disproportionate impact on newer and earlier-career employees.

### Miscellaneous employee contribution rates by tier and unit

Table 2 shows the total rates paid by employees toward CalPERS pension costs, as

compared to the normal cost, for fiscal year 2021-22 under the current cost-share language.

**Table 2: Miscellaneous employee contribution rates, fiscal year 2021-22**

Tier and unit	Employee contribution rate	Cost-share rate	Total employee pension contribution rate	Normal cost	Net employee contribution as % of normal
Tier 1 SEIU	8.00%	6.16%	14.16%	21.01%	67.38%
Tier 2 SEIU	7.00%	6.16%	13.16%	17.08%	77.03%
PEPRA SEIU	6.75%	6.16%	12.91%	13.82%	93.39%
Tier 1 AFSCME/Conf/Unrep	8.00%	5.53%	13.53%	21.01%	64.40%
Tier 2 AFSCME/Conf/Unrep	7.00%	5.53%	12.53%	17.08%	73.36%
PEPRA AFSCME/Conf/Unrep	6.75%	5.53%	12.28%	13.82%	88.86%

#### Cost-share trajectory

The assumption changes introduced by CalPERS in December of 2016 included a phase-in or ramp-up period for changes in order to partially shield member organizations from rate volatility but with the resultant effect that rates would continue to rise for a number of years. Unfunded liability rates, displayed as a percentage of anticipated payroll, have risen in recent years and are projected to continue to rise until fiscal year 2027-28. After that time, rates are expected to fall as unfunded liabilities are steadily reduced until being fully eliminated in 2043-44, absent any new unfunded liabilities created as a result of investment earnings not meeting expectations or new assumption changes, including those of implementing the funding risk mitigation policy. Under the language of the current agreements with miscellaneous units, this results in cost-share projections as shown below in Tables 3 and 4 with associated graphical representations. The effects of the discount rate change as a result of fiscal year 2020-21 investment returns has not yet been factored in and will likely not be fully known until summer of 2023 with an impact in fiscal year 2024-25 and beyond.

Table 3: Cost-share projections, AFSCME, confidential, and unrepresented				
Fiscal year	Unfunded liability contribution	Employer normal cost*	Cost-share	Net City rate
2021-22	16.86%	9.55%	-5.53%	20.88%
2022-23	19.02%	9.27%	-6.22%	22.07%
2023-24**	20.33%	9.02%	-6.75%	22.60%
2024-25	21.73%	8.79%	-7.34%	23.19%
2025-26	21.23%	8.56%	-6.97%	22.82%
2026-27	21.83%	8.36%	-7.17%	23.02%
2027-28	21.65%	8.16%	-6.98%	22.83%
2028-29	18.07%	7.95%	-5.09%	20.94%
2029-30	17.90%	7.78%	-4.92%	20.77%
2030-31	17.63%	7.62%	-4.70%	20.55%

\* Blended rate across tiers

\*\* First year the pension becomes a net cost to employment for PEPRAs members

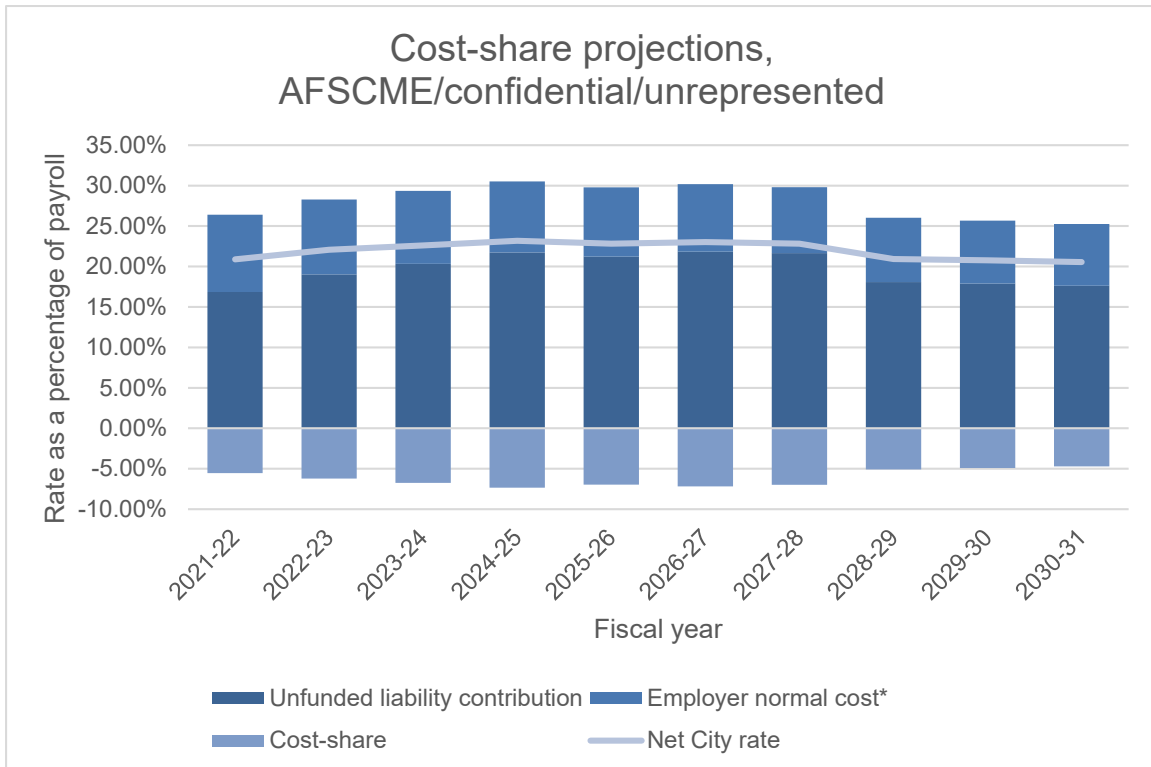
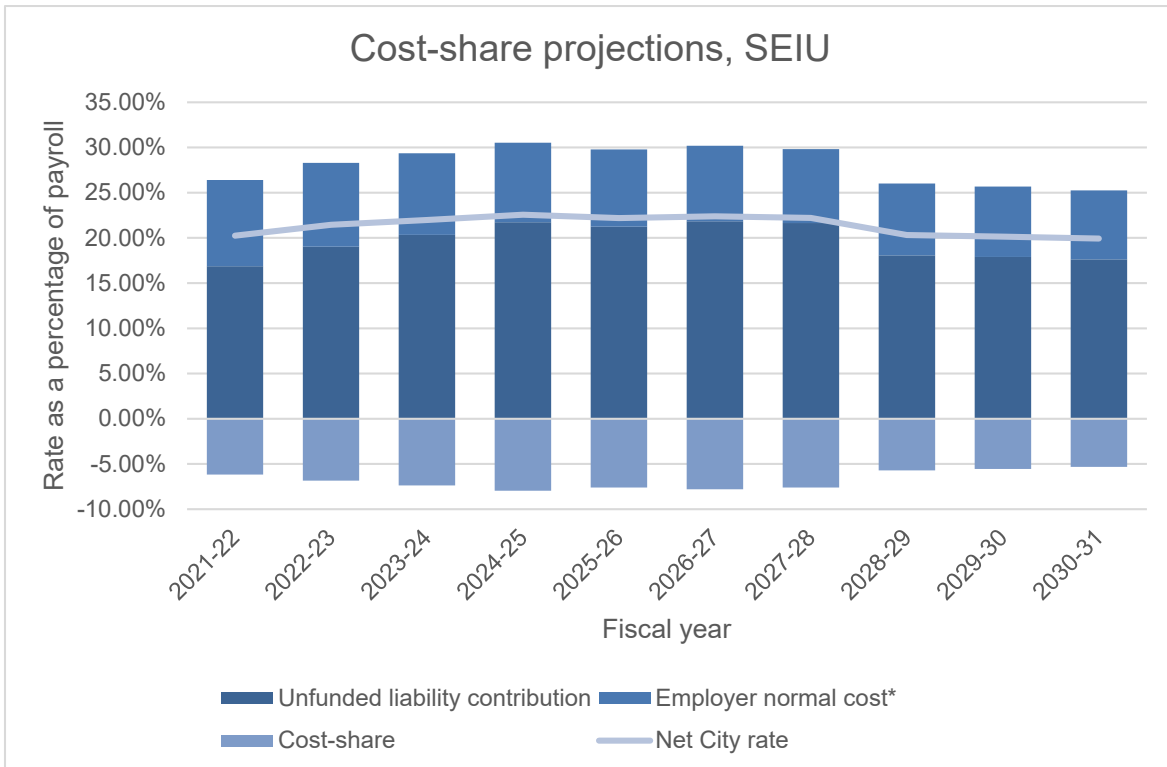

Table 4: Cost-share projections, SEIU				
Fiscal year	Unfunded liability contribution	Employer normal cost*	Cost-share	Net City rate
2021-22	16.86%	9.55%	-6.16%	20.25%
2022-23**	19.02%	9.27%	-6.85%	21.44%
2023-24	20.33%	9.02%	-7.38%	21.97%
2024-25	21.73%	8.79%	-7.96%	22.56%
2025-26	21.23%	8.56%	-7.60%	22.19%
2026-27	21.83%	8.36%	-7.80%	22.39%
2027-28	21.65%	8.16%	-7.61%	22.20%
2028-29	18.07%	7.95%	-5.71%	20.31%
2029-30	17.90%	7.78%	-5.54%	20.14%
2030-31	17.63%	7.62%	-5.33%	19.92%

\* Blended rate across tiers

\*\* First year the pension becomes a net cost to employment for PEPRA members







**STAFF REPORT**

**City Council**

**Meeting Date:**

**8/17/2021**

**Staff Report Number:**

**21-156-CC**

**Regular Business:**

**Receive report and recommendation from the city manager recruitment services request for proposals subcommittee, select a firm to perform the recruitment, authorize Mayor to execute professional services agreement with the selected firm, and appoint a City Council Ad Hoc Subcommittee for City Manager Recruitment**

**Recommendation**

Receive report and recommendation from the City Council ad hoc subcommittee on city manager recruitment services request for proposals (RFP), review RFP proposals (Attachment A), select a firm, authorize Mayor Combs to execute the City's form professional services agreement with the selected firm (Attachment B), create a new City Council Ad Hoc Subcommittee for City Manager recruitment specifying duration and purpose, and appoint up to two City Councilmembers to serve on the new ad hoc subcommittee.

**Policy Issues**

Menlo Park Municipal Code Section 2.08.010 establishes the position of city manager and provides that "The city manager shall be appointed by the City Council solely on the basis of his [sic] executive and administrative qualifications and ability. He [sic] shall hold office at and during the pleasure of the City Council."

**Background**

On June 10, the City Council formed a subcommittee (City Councilmembers Taylor and Wolosin) to work with City Manager Jerome-Robinson and City Attorney Doherty on retention of a recruiter to provide City Manager recruiting services. An RFP for city manager recruiting services was circulated and posted July 12. The City received six proposals.

**Analysis**

The subcommittee provided a final draft of the RFP document, and, July 12, City staff posted the RFP in compliance with established RFP practices. Table 1 summarizes the proposals, which are all provided as Attachment A.

City Council may award a contract to any qualified firm upon consideration of the subcommittee's report and recommendation. The RFP, consistent with Menlo Park Municipal Code Section 2.42.190, included the following factors for evaluating proposals. City Council maintains full discretion to weigh one or more factors higher than others in their final selection.

- The ability, capacity and skill of the bidder to perform the contract or provide the service required;
- The character, integrity, reputation, judgment, experience and efficiency demonstrated in previous contracts or services for the City or other contracting parties;
- The quality of performance demonstrated in previous contracts or services for the City or other contracting parties;
- The previous and existing compliance by the bidder with the laws and ordinances relating to a contract or service;
- The sufficiency of the financial resources and ability of the bidder to perform the contract or provide the services;
- The ability of the bidder to provide future maintenance and service for the use of the subject of the contract.

**Table 1: Request for Proposals responses - 2021 City manager recruitment services**

<b>Company</b> (listed alphabetically)	<b>Flat fee</b>	<b>Not-to-exceed reimbursable</b> (see proposal for details)	<b>Optional services</b> (see proposal for details)	<b>Work outside of scope</b> (billed hourly)
Bob Murray & Associates	\$23,000	\$7,000	multiple	\$250
CPS HR Consulting	\$25,000	\$0	\$3,500	\$125
Koff & Associates	\$18,000	\$7,000	n/a	n/a
Ralph Andersen & Associates	\$31,500	included in flat fee	\$3,500	\$50 - \$175
The Hawkins Company	\$32,000	\$7,500	n/a	\$250
William Avery & Associates	\$19,400	\$6,000	n/a	\$40 - \$200

The subcommittee’s recommendations will be attached to the agenda packet when ready (Attachment C.) The subcommittee’s report will include the recommended recruiting firm, the creation of a new City Council ad hoc subcommittee on city manager recruitment, and the new subcommittee’s purpose.

**Impact on City Resources**

City Council’s adopted fiscal year 2021-22 budget includes \$35,000 in general fund contract services for the City Manager recruitment.

**Environmental Review**

This action is not a project within the meaning of the California Environmental Quality Act (CEQA) Guidelines §§ 15378 and 15061(b)(3) as it will not result in any direct or indirect physical change in the environment.

**Public Notice**

Public notification was achieved by posting the agenda, with the agenda items being listed, at least 72 hours prior to the meeting.

**Attachments**

- A. City manager recruitment RFPs
- B. Form professional services agreement template
- C. Subcommittee recommendations to City Council

Report prepared by:  
Nick Pegueros, Assistant City Manager  
Nira Doherty, City Attorney



**A Proposal to Conduct an Executive Recruitment**

**for the Position of**

**CITY MANAGER**

**on behalf of the**



1544 Eureka Road, Suite 280  
Roseville, CA 95661  
(916) 784-9080  
(916) 784-1985 fax

August 4, 2021

MS. NIRA DOHERTY  
CITY ATTORNEY AND  
MEMBERS OF THE CITY COUNCIL  
CITY OF MENLO PARK  
701 LAUREL STREET  
MENLO PARK, CA 94025

Dear Ms. Doherty and Members of the City Council:

Bob Murray & Associates is pleased to submit a proposal to conduct the City Manager recruitment for the City of Menlo Park. The following details our qualifications and describes our systematic—yet flexible—method of identifying, recruiting, and screening outstanding candidates on your behalf. It also includes a proposed budget, timeline, and guarantee.

At Bob Murray & Associates, we pride ourselves on providing quality service to local governments, non-profit agencies, and private firms. Our recruitment process helps you to determine the direction of the search and the types of candidates you seek while capitalizing on our decades of experience and vast network of contacts to reach those candidates. Our expertise ensures that the candidates we present to the City of Menlo Park will match the criteria you have established, be a good fit for your organization, and be outstanding in their field.

Bob Murray & Associates recognizes that we work at the pleasure of the City Council and our job is to facilitate the Council's City Manager search. From the outset of the search, we work to establish a strong partnership with the Council to help ensure the placement of a City Manager who is ideally suited to its needs. In order to develop an effective search, we hope that City Council members make themselves available, as we seek the opportunity to meet with them individually to discuss their expectations for City of Menlo Park's new City Manager. We hope they will speak candidly with us regarding the traits they are looking for in the new City Manager. The insight garnered as a result of these meetings will be invaluable as we recruit and screen candidates for the position.

With respect to the City Manager recruitment and the City of Menlo Park, Bob Murray & Associates has placed over 200 City Managers since our firm's inception in 2000. We are currently conducting City Manager recruitments on behalf of the California cities of, Irvine, Los Altos Hills, Los Banos, and Mt. Shasta. We are also currently recruiting the Assistant City Manager on behalf of the California Cities of Bakersfield, Carpinteria, Cathedral City, Costa Mesa, and San Carlos. Our extensive contacts and knowledge of outstanding candidates will ensure you have a quality group of finalists from which to select the City of Menlo Park's next City Manager.

Recent City Manager recruitments we have completed similar in size and scope to your upcoming search include the following:

2021

Cudahy, CA  
Gridley, CA (City Administrator)  
Laguna Beach, CA  
Marion, IA (Deputy City Manager)  
Orinda, CA  
San Clemente, CA  
Santa Barbara, CA (Assistant City Administrator)  
Sonoma, CA  
South Pasadena, CA  
Willits, CA

2020

Fairfield, CA (Assistant City Manager)  
Healdsburg, CA  
Imperial, CA  
Jurupa Valley, CA (Assistant City Manager)

2019

Del Mar, CA  
El Segundo, CA  
Fairfield, CA  
Huntington Beach, CA  
Jurupa Valley, CA  
National City, CA  
Pico Rivera, CA  
Solvang, CA  
Tracy, CA

Yuba City, CA

2018

Arvin, CA  
Elk Grove, CA  
Lincoln, CA  
Lompoc, CA  
Madera, CA  
Roseville, CA

2017

Adelanto, CA  
Alhambra, CA  
Atwater, CA  
Boulder City, NV  
Compton, CA  
Covina, CA  
El Centro, CA  
Grass Valley, CA  
Marysville, CA  
Menifee, CA  
San Fernando, CA  
San Gabriel, CA  
Santa Fe Springs, CA  
St. Helena, CA  
Tracy, CA  
Willits, CA  
Windsor, CA (Town Manager)

We work as a team on every search at Bob Murray & Associates. Your Project Lead would be Valerie Gaeta Phillips. Ms. Gaeta Phillips is highly experienced in guiding elected bodies through the decision-making process and would not only direct and supervise the project team from beginning to end but also serve as your Recruiter.

To learn first-hand of the quality of our services and why the majority of our engagements come from repeat and referred clients, we invite you to contact the references listed on page 16 of the attached proposal.

We look forward to your favorable consideration of our qualifications. Please do not hesitate to contact us at (916) 784-9080 with any questions.

Sincerely,



Valerie Gaeta Phillips  
President, Bob Murray & Associates

## TABLE OF CONTENTS

<b>THE RECRUITMENT PROCESS</b> .....	<b>2</b>
STEP 1 DEVELOP THE CANDIDATE PROFILE.....	2
<i>Optional Service: Community and Staff Involvement</i> .....	2
STEP 2 DESIGN/DISTRIBUTE BROCHURE AND ADVERTISEMENTS .....	2
<i>Reaching Diverse Candidates</i> .....	3
STEP 3 RECRUIT CANDIDATES .....	3
STEP 4 SCREEN CANDIDATES .....	4
STEP 5 CONDUCT PRELIMINARY INTERVIEWS.....	4
STEP 6 SEARCH PUBLIC RECORDS.....	4
STEP 7 MAKE RECOMMENDATIONS .....	4
STEP 8 FACILITATE FINAL INTERVIEWS.....	5
STEP 9 CONDUCT BACKGROUND AND REFERENCE CHECKS .....	5
STEP 10 ASSIST IN NEGOTIATIONS.....	5
 <b>COMPLETE ADMINISTRATIVE ASSISTANCE</b> .....	 <b>6</b>
 <b>COSTS AND GUARANTEE</b> .....	 <b>7</b>
PROFESSIONAL FEE AND EXPENSES .....	7
<i>Optional Services</i> .....	7
GUARANTEE.....	8
 <b>RECRUITMENT SCHEDULE</b> .....	 <b>8</b>
 <b>FIRM PROFILE</b> .....	 <b>9</b>
 <b>REFERENCES</b> .....	 <b>16</b>

## **THE RECRUITMENT PROCESS**

Bob Murray & Associates' recruiters are specialists in finding the perfect fit, providing security and fairness to candidates and clients while ensuring the integrity of the search process. We understand that superlative recruiting for the City Manager will lead to superlative results for the City of Menlo Park. Outlined below are the steps in our proven recruitment process, refined through our 30+ years of experience in executive search.

### **STEP 1 DEVELOP THE CANDIDATE PROFILE**

Our understanding of the City of Menlo Park's needs will be key to a successful search. Valerie Gaeta Phillips will meet with the City Council and key stakeholders to learn as much as possible about the ideal candidate for the City Manager position. We want to become familiar with the values and culture of the organization, as well as to understand the current and future issues, challenges, and opportunities in the City of Menlo Park.

Ms. Gaeta Phillips will review and help define the City's wish-list regarding the ideal candidate's personality, management style, knowledge, skills, and abilities and will work with the City to identify expectations regarding education and experience. The City Council and Ms. Gaeta Phillips will discuss compensation, benefits, and other key information necessary to ensure that outstanding candidates are attracted to this opportunity. The profile we develop together at this stage will drive subsequent recruitment efforts.

#### *Optional Service: Community and Staff Involvement*

We find that many of our clients value a recruitment process that opens the opportunity for community members, business leaders, organization representatives, and employees to provide input regarding the ideal candidate. Our recruiters are skilled in designing and facilitating forums, town hall meetings, and online surveys that allow equitable involvement from a variety of constituencies and in consolidating feedback into a cohesive narrative of common themes.

If the City of Menlo Park so desires, we will work with the City Council to create a customized community and/or staff input process.

### **STEP 2 DESIGN/DISTRIBUTE BROCHURE AND ADVERTISEMENTS**

Ms. Gaeta Phillips and your dedicated Recruitment Coordinator will use the candidate profile developed with the City of Menlo Park to create a professional recruitment brochure, with the assistance of our professional graphic designer. The four-page, full-color brochure will describe the community, organization, position, ideal candidate, and compensation and will include pictures provided by the City of Menlo Park that you feel best represent your organization and your community.

Upon your approval, Ms. Gaeta Phillips will send the brochure by postal mail and email to a targeted audience, personally inviting potential candidates to apply for the City Manager position. We will also place the recruitment brochure on our website, which attracts over 11,000 unique hits



weekly and is a trusted resource for candidates seeking executive and professional positions. Two sample brochures are included in this proposal package for your reference.

Ms. Gaeta Phillips will also design an effective advertising campaign appropriate for the City Manager recruitment. Our broadest outreach comes through our active social media involvement on Facebook, LinkedIn, and Twitter, where upcoming and current positions are posted. Sources such as *Western City Magazine*, PublicCEO, and the Careers in Government website will be used to reach an extensive local government audience, while position-specific postings will be chosen to attract candidates who have built their careers in and are committed to the City Manager field.

Suggested City Manager-specific advertising sources for the City of Menlo Park’s search include:

- ICMA Newsletter
- League of Women in Government
- California City Management Foundation
- California City News

Bob Murray & Associates does not typically place ads with job aggregators or general job posting sites such as CareerBuilder, Monster, or Indeed, as we have found that the broad reach of these sites does not necessarily lead to quality candidates for executive and professional positions.

#### *Reaching Diverse Candidates*

Bob Murray & Associates, a woman- and minority-owned business, is proud of its commitment to attracting and placing diverse candidates. Not only do we place advertisements with websites designed to attract minority and female candidates, but our President, Valerie Phillips, is a member herself of many diversity-focused organizations including the Local Government Hispanic Network, the League of Women in Government, the Professional Women’s Network, Mexican Professionals, and Women Leading Government. She networks frequently with fellow members to gain insight into which potential candidates are leaders in their field.

Ms. Gaeta Phillips will seek to reach candidates in communities and organizations with demographic profiles and populations served like that of the City of Menlo Park, to maximize the potential for individuals from a wide variety of backgrounds, cultures, and life experiences to be considered for the City Manager position.

### **STEP 3 RECRUIT CANDIDATES**

The strongest candidates are often those who are successful and content in their current positions and need to be sold on a new opportunity. Our extensive network of contacts, developed through over 1,400 successful placements, is a primary source for identifying and obtaining referrals for these candidates. Our in-house database of 40,000 current and former executive and professional candidates is a valuable resource that can only be built over time—time that we have invested into perfecting our process for finding the right candidates for our clients. Our aggressive outreach efforts are focused on phone calls to personally invite potential applicants, answer questions, and allay any reservations, and these efforts are essential to the success of the City Manager recruitment.

#### STEP 4 SCREEN CANDIDATES

Following the closing date for the recruitment, Ms. Gaeta Phillips will screen all resumes we have received, using the criteria established in the candidate profile as a basis upon which to narrow the field of candidates. Internal candidates receive sensitive consideration, and Ms. Gaeta Phillips will discuss with the City Council how the City of Menlo Park wishes to proceed with these candidates.

#### STEP 5 CONDUCT PRELIMINARY INTERVIEWS

Ms. Gaeta Phillips will personally interview the top 10 to 15 candidates from the resume screening, with the goal of determining which candidates have the greatest potential to succeed in your organization. To reduce travel-related expenses to our clients and increase efficiency in the search process, these interviews are typically conducted via Skype, FaceTime, or other convenient videoconferencing applications.

During these in-depth interviews, Ms. Gaeta Phillips will explore each candidate's background and experience as it relates to the City Manager position, such as significant accomplishments, size and scope of responsibility, and organizational culture. In addition, Ms. Gaeta Phillips will discuss with the candidates their motivation for applying for the position and assess his/her knowledge, skills, and abilities. We will devote specific attention to establishing the likelihood of the candidate's acceptance of the position if an offer of employment is made.

#### STEP 6 SEARCH PUBLIC RECORDS

Under the direction of Ms. Gaeta Phillips, your dedicated Recruitment Coordinator will conduct a review of published print and online articles for each recommended candidate. Sources include Lexis-Nexis™, Google, social media, and our contacts in the field. This will alert Ms. Gaeta Phillips to any further detailed inquiries we may need to make before our recommendations are finalized.

#### STEP 7 MAKE RECOMMENDATIONS

Based on our findings during the preliminary interview process, Ms. Gaeta Phillips will recommend a limited number of candidates for your further consideration. She will make specific recommendations and will help facilitate discussions regarding the candidate pool, but the final determination of those to be considered will be up to you.

We typically recommend 6-8 candidates that we feel will best match your expectations, and we prepare a detailed written report on each candidate. This bound report provided to each member of the decision-making body includes:

- Candidate list with Recommended Finalists identified in *Group 1* and *Group 2* (primary and secondary recommendations), as well as *Internal* candidates
- Summary of experience, education, and salary information for each Recommended Finalist candidate
- Complete cover letter and resume for each Recommended Finalist candidate
- List of *Other Applicants* (those who did not meet minimum qualifications or were otherwise unsuitable, based on our screening process)

Bob Murray & Associates maintains all search records for a period of seven (7) years following each recruitment, and we are happy to forward cover letters and resumes for each applicant by postal mail or email as soon as the recruitment closes to new applications.

#### **STEP 8 FACILITATE FINAL INTERVIEWS**

Our years of experience will be invaluable as we help you develop an interview process that objectively assesses the qualifications of each candidate. We will work with the City of Menlo Park to craft and implement an interview approach that fits your needs. This may include individual and panel interviews by the City Council and key stakeholders, community/employee interview panels, writing and presentation samples, meet-and-greets, or another specialized process element Ms. Gaeta Phillips helps the City of Menlo Park to design.

Ms. Gaeta Phillips will be present on-site during the interviews to facilitate as necessary during the process and to guide discussion to consensus regarding final candidates. Bound interview books will be provided to each interview panel member containing:

- Recruitment brochure with candidate profile
- Interview schedule
- Suggested interview questions
- Experience summary, cover letter, resume, and rating form for each candidate
- Ranking forms for use during the panel interview process

We will work closely with your staff to coordinate and schedule interviews and candidate travel. Our goal is to ensure that each candidate has a very positive experience, as the way the entire process is conducted will influence the final candidates' perception of your organization.

#### **STEP 9 CONDUCT BACKGROUND AND REFERENCE CHECKS**

Ms. Gaeta Phillips and your Recruitment Coordinator will conduct detailed reference checks for up to three (3) final candidates. To gain an accurate and honest appraisal of the candidates' strengths and weaknesses, we will talk candidly with people who have direct knowledge of their work and management style. In addition to gaining a 360-degree view of candidates from the perspective of their supervisors, subordinates and peers for the past several years, we will make a point of speaking confidentially to individuals who may have further insight into a candidate's abilities but who may not be on their preferred list of contacts.

Your Recruitment Coordinator will work with candidates and our professional backgrounding firm, HireRight, to conduct credit, civil litigation, and motor vehicle record checks and verify candidates' degrees.

#### **STEP 10 ASSIST IN NEGOTIATIONS**

We recognize the critical importance of successful negotiations and can serve as your representative during this process. Ms. Gaeta Phillips knows what other organizations have done to put deals together with great candidates and what the current market is like for City Manager

positions in organizations like the City of Menlo Park's. She will be available to advise you regarding current approaches to difficult issues, such as housing and relocation. We will represent your interests and advise the chosen candidate and you regarding salary, benefits, and employment agreements, with the goal of putting together a deal that results in the appointment of your chosen candidate. With our proven experience and vested interest in a positive outcome, we can turn a very difficult aspect of the recruitment into one that is straightforward and agreeable for all parties involved.

## **COMPLETE ADMINISTRATIVE ASSISTANCE**

We receive many unsolicited testimonials each year from clients and candidates alike noting our prompt, considerate, accurate, and professional service during the search process. Throughout the recruitment, in time intervals that suit the City of Menlo Park, we will provide you with updates on the status of the search and attend to all administrative details on your behalf.

Candidates receive immediate acknowledgement of their applications, as well as personal phone calls and/or emails (as appropriate) advising them of their status at each critical point in the recruitment. Candidates who receive preliminary or final interviews and are not chosen to move forward in the interview process will receive personal calls from Ms. Gaeta Phillips on behalf of the City of Menlo Park.

It is our internal company standard that all inquiries from clients and candidates receive a response within the same business day whenever possible, and certainly within 24 hours if the inquiry is received during the work week. Ms. Gaeta Phillips will be available to the City of Menlo Park by office phone, cell phone, and email at any time to ensure a smooth and stress-free recruitment process.

## COSTS AND GUARANTEE

### PROFESSIONAL FEE AND EXPENSES

The fixed, flat professional services fee for conducting the City Manager recruitment on behalf of the City of Menlo Park is \$23,000. Services provided for in this fee consist of all steps outlined in this proposal, including three (3) meetings on site. The professional fee does not limit the amount of time invested by Bob Murray & Associates in promoting a successful outcome for this project. In fact, our mission for this project is to ensure we assist in identifying the right candidate for the City of Menlo Park. Therefore, Ms. Gaeta Phillips will contact the City at the first anniversary of the placement to confirm an effective transition has occurred.

The City of Menlo Park will also be responsible for reimbursing expenses Bob Murray & Associates incurs on your behalf. We estimate expenses for this project not to exceed \$7,000. Reimbursable expenses include (but are not limited to) such items as the cost of recruiter travel; clerical support; brochure development; placement of ads; credit and civil background checks; education verification; and public records searches. Postage, printing, photocopying, and telephone charges are allocated costs and included in the expense estimate. *In no instance will expenses exceed this estimate without prior approval from the City of Menlo Park.*

Expense reimbursement for candidate travel related to on-site interviews will be the responsibility of the City of Menlo Park.

Professional Fees and Reimbursable Expenses	
<b>Professional Services (Fixed Flat Fee)</b>	\$23,000
<b>Reimbursable Expenses</b> <i>Example costs and approximate amounts include:</i>	
Brochure Design and Printing (\$1,275)	
Advertising (\$3,100)	\$7,000
Background Checks – 3 candidates (\$550)	
Consultant Travel (\$1,500)	
Other expenses – supplies, shipping, clerical (\$575)	
<b>Not-to-Exceed Total</b>	<b>\$30,000</b>

#### *Optional Services*

- Community/Staff Input Forum: \$1,500/day, plus travel expenses
- Online survey with analysis of results: \$250
- Additional on-site meeting days: \$1,500/day, plus travel expenses
- Additional background checks: \$250/candidate
- Additional reference checks: \$500/candidate
- Other services: \$250/hour or \$1,500/day

## GUARANTEE

Should a candidate recommended by our firm position resign or be terminated within the first 12 months of employment, we will provide the City of Menlo Park with professional services to secure a replacement. Services will be provided at no cost, aside from expenses incurred on the City of Menlo Park's behalf during the new search. We are confident in our ability to recruit outstanding candidates and do not expect the City to find it necessary to exercise this provision of our proposal.

## RECRUITMENT SCHEDULE

We are prepared to start work on this assignment upon receipt of a signed professional services agreement or other written, authorized notification. A full search can be completed in 13-16 weeks from the date of initial meetings with our client.

The final recruitment schedule will be determined in collaboration with City of Menlo Park. A typical timeline of tasks and events is included here for reference.

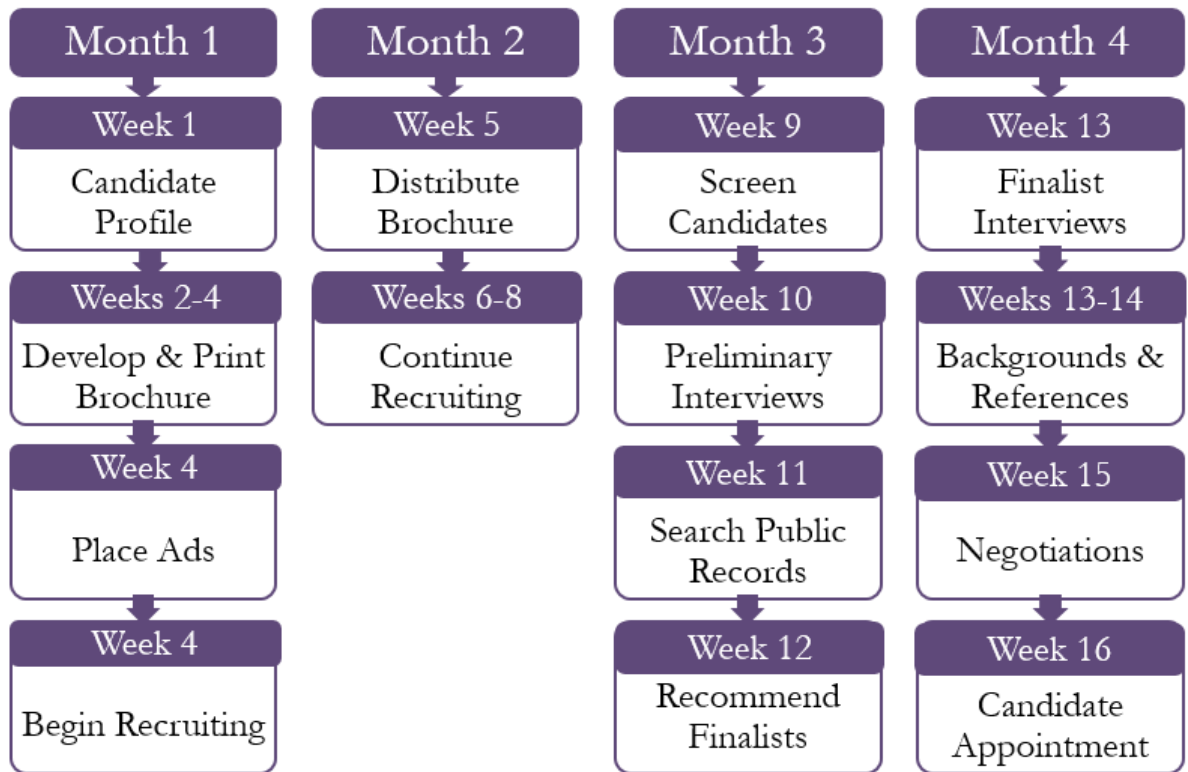

## FIRM PROFILE

### *OUR STAFF*

Bob Murray & Associates is a small firm focusing exclusively on executive search services. We have a team of eleven (11):

- ◆ Bob Murray, *Founder*
- ◆ Valerie Gaeta Phillips, *President*
- ◆ Gary Phillips, *Executive Vice President*
- ◆ Regan Williams, *Vice President*
- ◆ Joel Bryden, *Vice President*
- ◆ Yasmin Beers, *Senior Executive Recruiter*
- ◆ Carmen Valdez, *Senior Executive Recruiter*
- ◆ Adele Fresé, *Senior Executive Recruiter*
- ◆ Amber Smith, *Principal Recruitment Coordinator*
- ◆ Sky Baclig, *Senior Recruitment Coordinator*
- ◆ Gini Herndon, *Contracts Administrator/Bookkeeper*

### **BOB MURRAY, FOUNDER**

Mr. Murray—known simply as “Bob” to his clients and candidates throughout the western U.S.—brings over 40 years’ experience as a recruiter and is recognized as one of the top local government recruiters in the nation. He conducted hundreds of searches for cities, counties, and special districts and was called on to conduct searches for some of the largest, most complex organizations in the country—and some of the smallest. Bob conducted searches for chief executives, department heads, professional and technical positions, taking the lead on many of the firm’s most difficult assignments with great success. His clients retained him again and again, given the quality of his work and success in finding candidates for difficult to fill positions.

As our Founder, Bob currently takes on few searches personally but continues to be an active presence at Bob Murray & Associates, providing valued insight and experience to our team members regarding all aspects of the recruitment process.

Mr. Murray received his Bachelor of Science Degree in Criminology from the University of California at Berkeley with graduate studies in Public Administration at California State University at Hayward.

### **VALERIE GAETA PHILLIPS, PRESIDENT AND RECRUITER**

Ms. Gaeta Phillips has over 18 years of recruiting experience, including more than a decade of recent experience in executive search for public, private, and startup companies nationwide. Since joining Bob Murray & Associates, Valerie has completed over 160 searches in a diverse range of fields, including city and general management, planning, finance, human resources, transportation, communication and public relations, community and economic development, information technology, parks and recreation, and operations. She has recruited at all levels of municipal and

non-profit organizations, from technicians and engineers to Executive Directors and Chief Executive Officers.

Valerie is valued for her passion for finding and retaining the most outstanding candidates for even the most difficult or untraditional assignments and for her commitment to her clients' success; she is also active in a variety of industry organizations and in diversity-focused associations. Valerie is called upon often to serve as an expert speaker on topics such as managing one's online reputation, diversity issues in municipal and non-profit leadership, and how to identify a good "fit" for organizational culture.

Ms. Gaeta Phillips, along with Executive Vice President Gary Phillips, has a passion for helping people, evidenced by fundraising, sponsorship, and involvement in raising awareness for organizations such as Autism Speaks, the UC Davis M.I.N.D. Institute, and the Northern California Special Olympics.

#### **GARY PHILLIPS, EXECUTIVE VICE PRESIDENT AND RECRUITER**

Since joining Bob Murray & Associates, Mr. Phillips has completed over 125 searches for executives and professionals in a wide variety of fields including animal services, city and general management, planning, legal counsel, cyber security, and human resources. Gary's clients have ranged from municipal government to non-profit and private sector organizations, and he has sourced outstanding candidates for positions from the level of division managers up to City Managers, Executive Directors, and General Managers.

Gary started his career with a New York-based Fortune 100 company and quickly became a Senior Manager, building and running a large customer service organization that eventually expanded to 13 countries in Europe. He proceeded to hold senior leadership positions in several Fortune 500 companies, with noted successes such as building an organization from two to 250 employees worldwide and growing a company from 800 to 1200 employees.

As part of an executive acquisition and recruiting team, Gary helped build a start-up enterprise software company in San Francisco, recruiting top-notch talent and building a world-class organization. He has maintained customer relationships in the public sector and the private sector, including medical and financial institutions. He prides himself on finding key talent and offering the best customer service to his clients.

Mr. Phillips, along with Ms. Gaeta-Phillips, is involved in his community as a soccer coach, as an organizer of fundraisers for Autism Speaks and the UC Davis M.I.N.D. Institute, and as a sponsor of the Northern California Special Olympics. Mr. Phillips received his Associate of Science degree and completed additional coursework at Rochester Institute of Technology, NY.

#### **REGAN WILLIAMS, SENIOR VICE PRESIDENT AND RECRUITER**

Mr. Williams brings 30 years of local government experience to Bob Murray & Associates and has over 17 years of experience in executive recruitments with our firm. In his time with Bob Murray & Associates, Regan has conducted over 275 executive searches ranging from managers and department heads to City Managers, Executive Directors, and General Managers. If Regan were



to have a recruiting specialty, it would be public safety positions: he has personally conducted over 60 Police Chief and 20 Fire Chief recruitments.

Prior to joining Bob Murray & Associates, Regan served as Director of Public Safety with the City of Sunnyvale, CA. He was involved in the development of some of Sunnyvale's most innovative public safety programs and has a national reputation for excellence in law enforcement, as well as in law enforcement executive recruiting. Regan's clients find his prompt and personal attention, insight, and expertise in recruitment and selection an asset. He is often called upon to recruit for difficult-to-fill law enforcement positions, such as the position of Police Chief or City Manager in challenging political environments.

Mr. Williams received his Bachelor of Science Degree in Administration of Justice from San Jose State University. He is also a graduate of the FBI National Academy.

### **JOEL BRYDEN, VICE PRESIDENT AND RECRUITER**

Mr. Bryden has over 30 years of local government experience that he brings to the firm, having retired as Chief of Police in Walnut Creek, CA prior to joining Bob Murray & Associates in 2013. Throughout his career, Joel has been involved in public sector consulting, with vast experience in hiring and promotional processes, as well as interviewing candidates for advancement in all aspects of local government.

Joel has a solid reputation as a leader in the public sector and his ability to find and evaluate outstanding applicants for our clients is invaluable in the search process. Since joining Bob Murray & Associates, Joel has conducted over 100 recruitments in a broad range of sectors including police, fire, building, planning, city management, and general management. He is often called upon to recruit specialized or difficult-to-fill positions, such as Independent Police Auditor.

Mr. Bryden is a graduate of the FBI National Academy and obtained his Bachelor of Arts Degree in Communication from San Diego State University. He is currently based in Walnut Creek, CA.

### **YASMIN BEERS, SENIOR EXECUTIVE RECRUITER**

Yasmin Beers brings over 33 years of municipal government experience to Bob Murray and Associates. Yasmin retired as the City Manager for Glendale with a population of over 200,000. She served as Chief Executive Officer overseeing close to 2,000 employees serving in Police, Fire, Public Works, Parks, Community Development, Library Arts & Culture, Innovation Performance & Audit, and Water & Power to name a few.

Yasmin's three decades of experience in public service brings extensive background in public sector finance, human resources management, contract negotiations, strategic planning & organizational leadership, policy development, emergency response & planning, team building and performance improvement. Throughout her career, Yasmin has had a great deal of experience in recruiting, selecting and hiring employees for executive and management level positions with a focus on the organizational needs and culture.

Yasmin currently serves on the Glendale Adventist Medical Center's Civic Advisory Board and the Advisory Board for Village Christian School. Yasmin is a past member of Soroptimist

International of Glendale where she served as President in 1999/2000. She is a past board member of Glendale Healthy Kids, Salvation Army and the American Red Cross. In 2011 the Glendale Chamber of Commerce recognized Yasmin as Woman of the Year; in 2013 she was the recipient of The Armenian American Woman of Excellence Award; in 2014 Yasmin was recognized by the Glendale Educational Foundation for her distinguished service and philanthropic efforts; in 2015, YWCA awarded Yasmin with the Heart & Excellence Award; in 2017, she was recognized by Business Life Magazine as a Women Achiever; and in 2018 the California State Senate recognized Yasmin as one of the Woman of the Year, each a tribute to her core values that represent her civic responsibilities, volunteerism and community service.

Yasmin has a Bachelor of Arts degree in Political Science from California State University, Northridge and a Master's degree in Organizational Leadership from Woodbury University.

### **CARMEN VALDEZ, SENIOR EXECUTIVE RECRUITER**

Carmen Valdez provides executive recruitment and human resource services to municipal government agencies and non-profits. She has more than 25 years' experience in executive search, general human resources, classification and compensation, testing, policy development, performance management, team building, organizational development, discipline, and other employee relations activities.

Carmen has most recently been consulting with Municipal Resource Group, prior to which she spent over 30 years with the City of Milpitas, a Silicon Valley city of 70,000 residents. In this capacity, she was responsible for collective bargaining, PEPRA and Affordable Care Act implementation, modernizing Human Resource services to improve efficiencies and reduce costs, revamping the Workers Compensation service delivery and completing a City-wide strategic plan. Carmen also spent almost 2 years as the Director of Recreation Services.

In addition to her significant experience in the public sector, Carmen earned a Bachelor of Arts degree in Business from University of Phoenix. She is also a member of Local Government Hispanic Network and League of Women in Government. She is an avid runner and enjoys giving back to her community.

### **ADELE FRESÉ, SENIOR EXECUTIVE RECRUITER**

Adele Fresé brings 27 years of local government experience to Bob Murray & Associates, having retired as Chief of Police in Salinas, CA prior to joining the firm in 2021. Adele began her public service career in 1985 as an active-duty member of the United States Marine Corps before serving the City of Corpus Christi for 20 years.

Adele has extensive experience in hiring and promotional processes, as well as interviewing candidates for advancement in all aspects of local government.

During her 7 years as a Chief of Police, Adele exercised strong leadership and implemented monumental changes leading to the diversification of her agency's sworn staff. Adele's commitment to collaboration with the public and law enforcement agencies earned her the Partner of the Year Award from Homeland Security Investigations, and her Department the Community Policing Award from the Community Policing Institute of California.

Adele received her Bachelor of Science degree in Criminal Justice Administration from California State University at Hayward, and a minor degree in Sociology. She earned a Master of Science in Public Safety, completed the Senior Executives in State and Local Government program at the Harvard Kennedy School, and PERF's Senior Management Institute for Police. She is a Texas Certified Public Manager.

#### **AMBER SMITH, PRINCIPAL RECRUITMENT COORDINATOR**

As Principal Recruitment Coordinator with Bob Murray & Associates, Ms. Smith acts as a liaison between clients and candidates from beginning to end of each recruitment process. Under the direction of each client's assigned Recruiter, Amber is responsible for the development and distribution of position recruitment and advertising materials, client research, reference and background checks, responding to requests for proposals, and providing a broad range of support services for the recruiting team. She also provides leadership for our in-house staff and is an invaluable resource.

Amber brings over a decade of client-oriented customer service, administrative, and management experience to Bob Murray & Associates. Since joining our team in 2013, she has shown a commitment to working as a partner with clients and candidates to provide a quality service and experience.

Ms. Smith received her Bachelor of Arts degree in Business Administration from La Sierra University, Riverside, California.

#### **SKY BACLIG, SENIOR RECRUITMENT COORDINATOR**

A Ms. Baclig is a Senior Recruitment Coordinator with Bob Murray & Associates and is an essential part of our hiring experience. She partners closely with the executive recruiters to support hiring initiatives and is responsible for facilitating the movement of candidates through the recruitment process.

Her responsibilities entail everything from creating marketing materials, posting available positions to job boards, candidate research, interview scheduling, conducting background checks, and ensuring the overall hiring process runs smoothly.

Sky graduated from California State University Sacramento with her bachelor's degree in Liberal Studies. She has over a decade of client service experience and 5 years in Human Resources. She possesses thorough knowledge of Human Resources best practices and relies on her service-oriented attitude to support management/clients and team.

She has a passion for helping people and connecting both personally and professionally. Outside of the workplace, Sky likes to spend time with her family, her dog, Oliver, and travel the world.

#### **GINI HERNDON, CONTRACTS ADMINISTRATOR/BOOKKEEPER**

Ms. Gini Herndon is the Contracts Administrator/Bookkeeper at Bob Murray & Associates. Ms. Herndon is the first point of contact at Bob Murray & Associates and has an extensive administrative background in business law.

Ms. Herndon is known for her collaborative approach as she works closely with our internal team and clients to ensure a successful search. As a first point of contact, Ms. Herndon is highly professional and maintains a high level of confidentiality and sensitivity.

## *CORPORATION*

Bob Murray & Associates was founded in May 2000 and operated under the corporation name MBN Services, Inc. until June 2014; our new corporation name is GVP Ventures, Inc., incorporated in California in 2014. Contact information for the corporation and the firm is as follows:

GVP Ventures, Inc. OR Bob Murray & Associates  
1544 Eureka Road, Ste. 280  
Roseville, CA 95661  
(916) 784-9080  
apply@bobmurrayassoc.com

Our corporation and firm are financially sound (and have been so since 2000), with documentation from our accountant available to your organization prior to final execution of a professional service agreement. We have never been involved in any litigation, aside from our personnel serving as expert witnesses when called to do so.

## *PROFESSIONAL ASSOCIATIONS*

Our firm, represented by either our President or our Executive Vice President, are involved in the following organizations to remain engaged with current and future issues relevant to the work we conduct on behalf of clients like City of Menlo Park:

- California Special Districts Association – *Member*
- California City Management Foundation (CCMF) – *Member*
- International City/County Management Association (ICMA) – *Member*
- League of California Cities – *League Partner*
- League of Women in Government – *Sponsor/Member*
- Municipal Management Association of Northern California (MMANC) – *Sponsor/Member*
- Municipal Management Association of Southern California (MMASC) – *Sponsor/Member*
- National Forum for Black Public Administrators (NFBPA) – *Committee member for Marketing and Branding*

Members of our leadership team not only attend events sponsored by these associations but are also frequently called upon to serve as panel members and to provide specialized lectures regarding industry-specific issues.

Recent and upcoming speaking engagements and trainings provided by our staff include:

- “Role of the Chief” class, presented by Joel Bryden on behalf of the California Police Chiefs Association
- Organization of Latino Affairs invited speaker, Valerie Phillips for Hispanic Heritage Month; and
- “The Next Step on Your Career Ladder: A Rung Up or a Missed Step? What City Managers are Seeking to Create a Dream Team,” Bob Murray & Associates is a leading participant on the MMANC 2019 Conference Panel

## REFERENCES

Clients and candidates are the best testament to our ability to conduct quality searches. Clients for whom Bob Murray & Associates has recently conducted similar searches are listed below:

**CLIENT:** City of Fairfield, CA  
**POSITION:** Police Chief  
**REFERENCE:** Mr. Stefan Chatwin, City Manager  
(208) 771-4350

**CLIENT:** City of Healdsburg, CA  
**POSITION:** City Manager  
**REFERENCE:** Mr. David Hagele, Council Member  
(707) 578-7800

**CLIENT:** City of Orinda, CA  
**POSITION:** City Manager  
**REFERENCE:** Ms. Amy Worth, Mayor  
(925) 212-4511

*We appreciate the City of Menlo Park's consideration of our proposal and look forward to working with you.*





# CITY OF ORINDA, CA

INVITES YOUR  
INTEREST IN  
THE POSITION OF

# CITY MANAGER



**BOB MURRAY  
& ASSOCIATES**

EXPERTS IN EXECUTIVE SEARCH

Page M-3.23

## THE COMMUNITY

The City of Orinda is situated in southwest Contra Costa County, within a group of secluded valleys surrounded by a distinctive backdrop of rolling hills and mature trees. Its unique, semi-rural setting is approximately 15 miles east of San Francisco and transitions into neighboring communities of Moraga and Lafayette.

Natural beauty, excellent schools, safety, history, culture, serenity, and its proximity to major San Francisco Bay locations and activities with easy freeway access and its own BART station make Orinda a delightful place in which to live, work, and visit. Orinda is a family-oriented community with a semi-rural setting. In contrast to the more urban existence of the surrounding area, the tree-studded hillsides of the 12.8 square-mile city contribute to Orinda's aesthetic beauty.

The Orinda community is surrounded by several large parks and regional preserves, and is at the crossroads of many National and Regional Trail systems. The City is home to a historic Community Center, Orinda Theatre, and a state-of-the-art public library.

## THE ORGANIZATION

The City of Orinda is committed to providing excellent service to the community with a focus on public safety, sound land use planning, infrastructure improvements, and responsible fiscal management of City funds. The City offers the following function to better service its citizens: Administrative Services, Parks and Recreation, Planning, Police, and Public Works and Engineering. Incorporated as a city in 1985, Orinda has a reputation as a well-managed and stable municipal government with a population of approximately 19,000.

The City Council is comprised of five elected officials each serving four-year terms. The City Council, each year prior to adopting an operating budget, establishes major goals and objectives during their public Strategic Planning Workshops. The major goals and objectives set the blueprint for the City's priorities during that year.

The Fiscal Year 2020-2021 adopted Operating Budget is \$15.9 million (all funds), which is supported by \$13.9 million in General Fund revenue. The City has a large Capital Improvement Program and total budget expenditures including Operating Budget and CIP is \$31.5 million.

The Capital Projects in recent years have been primarily improving streets and roads with \$45 million in voter-approved General Obligation Bonds. The proceeds from the Bonds are expected to be fully expended this year. The City also has a ½ cent general sales tax that is prioritized for street rehabilitation and drainage.

The City of Orinda is situated in southwest Contra Costa County, within a group of secluded valleys surrounded by a distinctive backdrop of rolling hills and mature trees.

On November 3, Orinda voters approved a general sales tax measure of 1 cent which will replace the current ½ cent and extend the collection for 20 years. The City Council priorities established for the funds include Wildfire Fuel and Risk Reduction, Disaster Preparedness Planning, Critical Drainage Infrastructure, and Maintenance of Roads. The City has a dedicated and professional staff of 32 full-time budgeted employees supplemented with part-time and seasonal staff. The City contracts with the Contra Costa County Office of the Sheriff for police services, and the department is comprised of 14 sworn personnel. The City has two significant contracts with private sector companies – one for landscaping and one for City-wide facility janitorial services which will both go out to bid in 2021.

## THE POSITION

Appointed by the City Council, the City Manager has responsibility for supervising government operations and implementing the policies adopted by the City Council. The City Manager oversees the City budget, personnel matters, and serves as the Council's chief policy advisor. Essential responsibilities of the City Manager position include, but are not limited to: directing and managing the development and implementation of City goals and objectives; representing the City to other public agencies, community-based organizations, elected officials, outside agencies, and the media; identifying opportunities for organizational improvement; directing and overseeing disaster and crisis management; and responding to and resolving sensitive citizen inquiries and complaints.

The Office of the City Manager includes responsibility for Human Resource Administration, Information and Telecommunication Systems, and Public Information.





## ISSUES, CHALLENGES, & OPPORTUNITIES

Residents in Orinda are active and engaged in local government. Examples of current issues, challenges and opportunities are:

- Development and implementation of programs to mitigate the fire danger in Orinda in partnership with the Moraga Orinda Fire District. Community interest in continuing to increase fire prevention efforts is high.
- Strengthening the City's financial base. The City receives approximately 7 cents of the property tax dollars and is among the lowest of the 19 Contra Costa Cities in per capita sales tax.
- Address ongoing challenges with road maintenance, fire prevention, and flooding.
- Issues raised regarding private street maintenance in light of voter approved taxes for the repair of public streets.
- Completing and implementing a Downtown Precise Plan and complying with State Housing Law as part of the required update to the Housing Element.
- Working with the City Council and implementing appropriate feasible measures to address policing issues being discussed nationwide and increased interest in community programs highlighting issues of diversity and inclusion.



## THE IDEAL CANDIDATE

The City of Orinda is seeking a highly qualified, energetic, hands-on professional to fill its City Manager position. An exemplary leader who will inspire a shared vision, encourage creativity, and foster a high-performing, accountable, and service-oriented organization by setting clear direction, goals, and expectations is sought. The Council seeks a candidate who demonstrates open communication and is responsive and approachable. An individual who exhibits a compassionate and sincere approach to every aspect of the City Manager's role will be highly valued. Professionalism, accessibility to the public, a customer-service orientation, transparency, and innovation are valued traits.

The ideal candidate will demonstrate not only a commitment to empowering staff, but also the ability to personally engage in the smooth and efficient operation of the City. The successful candidate will be an individual who demonstrates respect for and is able to balance the needs of the Council, staff, and department heads and who is able to act

apolitically in support of the Council as a whole. A candidate that will lead collaboratively and be respectful of others is highly desired.

The City seeks a City Manager who will be committed to the community and to quality, responsive service for Orinda's diverse citizenry, both organizationally and personally. The City Manager should nurture an environment of trust, both in the organization and the community. Candidates who will roll up their sleeves and lead by example will be valued. The ideal candidate will build strong relationships within the community and work collaboratively with other agency partners. Strong interpersonal skills and unquestioned integrity will be highly valued. The City is seeking an individual who is comfortable with the public visibility of the City Manager's role.

The incoming City Manager will be a seasoned individual and forward-thinking visionary who is fiscally responsible and capable of pursuing downtown revitalization and ensuring the long-term financial stability of the City. The ideal candidate will provide clear instruction to staff, engaging and building relationships with the business community, and bringing a broad perspective to future developments with sensitivity to the uniqueness and scale of Orinda.

The typical candidate will have knowledge of current social, political, and economic trends and operating challenges of municipal government; principles and practices of municipal government budget preparation and administration; modern and highly complex principles and practices of municipal government management, administration, and organization; and pertinent Federal, State, and local laws, codes, and regulations.

The Council seeks a candidate who demonstrates open communication and is responsive and approachable.

Candidates must possess a minimum eight (8) years of increasingly responsible experience in a local public agency in an administrative and managerial capacity involving the development and administration of organization-wide policies and procedures and the supervision of management-level employees. A Bachelor's degree from an accredited college or university with major coursework in business administration, public administration, or a related field is required; a Master's degree is highly desirable.

## THE COMPENSATION

The annual salary for the City Manager position is dependent upon the qualifications and experience of the selected candidate. The City of Orinda offers an excellent benefits package including:

**401(a) Retirement** – City contributes 13% of base salary to an ICMA 401(a) Money Purchase Plan defined contribution plan plus the City will match up to 3% contributed by the employee into the 401(a) plan. Employees may contribute up to 10% to the 401(a) Plan based on a designation at the beginning of employment.

**The City does not provide a defined benefit pension plan (i.e., CalPERS).**

**457 Deferred Compensation** – Employees have an option of participating in an ICMA-RC 457 deferred compensation plan where contributions are from employee earnings.

**CalPERS Medical** - The City offers several medical benefit plan options for the employee and his/her dependents. The 2021 City maximum contribution rates for single is \$808.60 monthly, \$1,617.19 monthly for 2-Party, and \$2,115.46 monthly for family. An in-lieu medical option is available upon proof of medical coverage for the employee and all his/her dependents.

**The City does not participate in Social Security, except for Medicare premiums.**

**Dental** – City pays full family premium for dental coverage.

**Vision** – City pays full family premium for vision coverage.

**General Leave** – Combined sick leave and vacation: 25 days per year.

**Administrative Leave** – 80 hours per fiscal year

**Holidays** – The City observes 12.5 paid holidays. This includes 2 floating holidays.

**Life Insurance/AD&D and Disability** – The City pays for a life insurance policy for an amount equal to one times the annual salary (up to max of \$150,000), as well as the cost for Long Term Disability.

**The City participates in SDI, which is fully funded by the employee.**

**Flexible Spending** – The City offers a Flexible Benefits Plan for out of pocket health care expenses and dependent care expenses.

**Auto allowance** – To be negotiated.



## TO APPLY

If you are interested in this outstanding opportunity, please apply online at:

**[www.bobmurrayassoc.com](http://www.bobmurrayassoc.com)**

to apply online.

**Filing Deadline:  
December 13, 2020**

Following the filing deadline, resumes will be screened according to the qualifications outline above. The best-suited candidates will be invited to personal interviews with Bob Murray & Associates. A select groups of candidates will be asked to provide references once it is anticipated that they may be recommended as finalists. References will be contacted only following candidate approval. Finalist interviews will be held with the City of Orinda. Candidates will be advised of the status of the recruitment following selection of the City Manager.

If you have any questions, please do not hesitate to contact Mr. Gary Phillips at:

(916) 784-9080



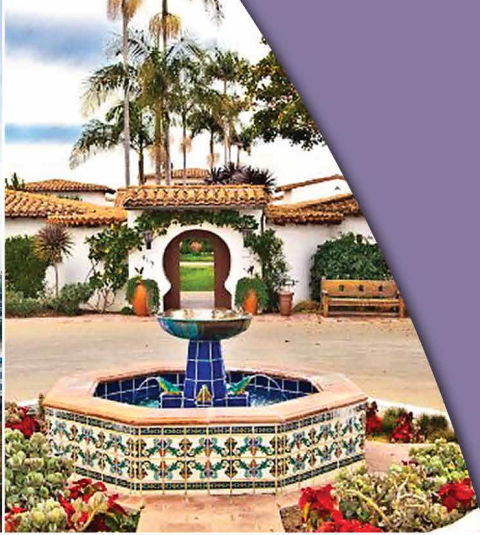

INVITES YOUR  
INTEREST IN  
THE POSITION OF  
**CITY MANAGER**



**BOB MURRAY  
& ASSOCIATES**  
EXPERTS IN EXECUTIVE SEARCH  
Page M-3.27

What was once a small residential village tied to its historical setting as an outpost along El Camino Real, San Clemente has matured into a diverse, full-service suburban community.

## THE COMMUNITY

The beautiful southern California community of San Clemente has 4.7 miles of stunning beaches and great surf that draw visitors on a year-round basis. The city is a family-oriented community of more than 65,500 residents and encompasses 18.5 square miles. The most southern city in Orange County, San Clemente is located midway between Los Angeles and San Diego, just north of the undeveloped lands of Camp Pendleton.

As San Clemente has grown in population, it has held steadfast to its heritage as the Spanish Village by the Sea. What was once a small residential village tied to its historical setting as an outpost along El Camino Real, San Clemente has matured into a diverse, full-service suburban community.

With its natural beauty and outstanding amenities, San Clemente maintains an exceptional quality of life for its vibrant and engaged citizenry. The city offers a unique blend of residential choices, community events, performing arts, recreational activities, award-winning schools, and excellent business opportunities. Listed in the Top 100 Safest Cities, San Clemente enjoys quality public safety as well as parks and recreation services. San Clemente provides its residents and visitors with a variety of retail shopping experiences and services; including the historic, pedestrian-friendly downtown, Avenida Del Mar, along with the Pier Bowl area that is part of a picturesque city-maintained beach trail.

While San Clemente reflects a relaxed beach environment and atmosphere, there is also a culture of strong civic awareness. San Clemente residents are bright and actively involved, which leads to an enhanced sense of community, and a higher standard for development, historic preservation, and urban design.

With its world-renowned surf breaks, San Clemente is also a premier surfing destination. This coastal jewel has family-friendly beaches, a network of pedestrian and bicycle trails, rugged hills and canyons, clean air, and a mild Mediterranean climate that enhances the community's distinctive seaside lifestyle.

## THE ORGANIZATION

The City was founded and incorporated in 1928 and now spans 18.5 square miles over rugged hills, coastal canyons, and majestic coastline. The many residents and visitors to the city enjoy 20 community parks, 6.8 miles of ridgeline trails, 2.3 miles of coastal trails, several championship golf courses, and over 20 acres of beautiful beaches.

The City of San Clemente operates under a City Council/City Manager form of government. The City Council consists of five members, elected at-large, for four-year overlapping terms of office. Non-partisan City elections are held



in November of even-numbered years for Council Members. The City Council acts as the legislative body, to set policy, approve the budget, pass local laws which are incorporated into the Municipal Code, and to give direction on matters concerning the City.

The City Departments include the City Clerk, Beaches, Parks & Recreation, Community Development, Finance & Administrative Services, Public Works and Utilities. The City contracts police and fire services with the Orange County Sheriff's Department and Orange County Fire Authority. More detail to the structure of the City's services can be found in the Organizational Chart.

## THE POSITION

The City Manager supervises and directs the administration of the various City departments; presents recommendations and information to enable the City Council and the Successor Agency to make decisions on matters of policy; coordinates the City's working relationship with external agencies and organizations; oversees the planning and funding of major city projects; serves as a liaison to improve communications between the City Administration, community organizations and citizens; prepares the News for City Hall quarterly publications; and works to maximize efficiency and customer satisfaction with City services.

The incoming City Manager will plan, direct, manage and oversee the activities and operations of the City of San Clemente including its operating departments, public safety contracts and provide complex administrative support to the City Council.

Essential responsibilities and duties may include, but are not limited to, the following:

- Assume full management responsibility for all City operations, including the Community Development Department, Public Works Department, Beaches,

Parks and Recreation Department, Utilities Department, Finance and Administrative Department and Public Safety contracts; recommend and administer policies and procedures.

- Direct the development and implementation of the City's goals, objectives, policies and priorities for recommendation to the City Council as appropriate.
- Establish, within City policy, appropriate service and staffing levels, monitor and evaluate the efficiency and effectiveness of service delivery methods and procedures, and allocate resources accordingly.
- Plan, direct and coordinate, through Department heads, the work plan for the City; assign projects and programmatic areas of responsibility; review and evaluate work methods and procedures; and meet with management staff to identify and resolve problems.
- Assess and monitor workload, administrative support systems, and internal reporting relationships to identify opportunities for improvement.
- Select, motivate and evaluate personnel; resolve personnel concerns and issues, and maintain the City's labor relations program.
- Oversee the development and administration of the City budget; approve the forecast of funds needed for staffing, equipment, materials and supplies; and approve expenditures and implement budgetary adjustments as appropriate and necessary.
- Oversee the City's Economic Development program; establish and implement efforts to retain new investment; and maintain an effective work relationship with the business community.
- Serve as Executive Director of the City's Successor Agency.
- Explain, justify and defend City programs, policies and activities; negotiate and resolve sensitive and controversial issues.
- Represent the City to all outside agencies, coordinate City activities with those of other cities, counties, the state and organizations.
- Provide staff assistance to the City Council; prepare and present staff reports and other necessary correspondence.
- Provide staff support to assigned boards and commissions.
- Attend and participate in professional group meetings; stay abreast of new trends and innovations in the field of city management and administration.
- Respond to media inquiries and coordinate the City's overall communication program.



## THE IDEAL CANDIDATE

The City of San Clemente seeks a City Manager that is an experienced administrator, a forward-thinking visionary who is business friendly and capable of handling economic development while ensuring the long-term financial stability of the City. Exceptional interpersonal and communication skills are essential for a candidate's success in this search. The ideal candidate will be a public executive with a record of demonstrated leadership in successfully guiding a full-service local government under a Council/Manager form of government. The candidate should have the tenacity to work through complex, long-term and often difficult issues and projects and the courage to make tough decisions when necessary.

The ideal candidate should be a proactive collaborator who can think analytically and act strategically; an individual who is energetic, communicates openly, values the experience and knowledge of the City's staff, and maintains accountability throughout the organization will be valued. The ideal candidate must be flexible and able to adapt to change; an individual with strong financial acumen who is politically astute, yet apolitical, is sought.

The candidate should have the tenacity to work through complex, long-term and often difficult issues and projects and the courage to make tough decisions when necessary.

Qualified candidates must possess equivalent to a bachelor's degree from an accredited college or university with major course work in public administration, business administration or a related field; an advanced degree in public administration or a closely related field is desirable; and seven (7) years of increasingly responsible experience in municipal government, including five (5) years of administrative and supervisory responsibility with strong budget experience.

## THE COMPENSATION

The salary for the City Manager is dependent upon qualifications and experience. The City also offers an attractive benefits package that includes:

**Retirement** – CalPERS Retirement. As of 7/2/18 Classic Member: 2% @ 55 CalPERS Retirement Plan Employee contribution: 7% (of the 7% employee contribution). In addition to the above contributions, the City contributes the Employer share plus payments towards any unfunded liability  
PEPRA New Member: 2% @ 62 CalPERS Retirement Plan Employee Contribution Amount: 6.25%

In addition to the above contributions the City contributes the Employer share plus payments towards any unfunded liability.

**Health Insurance** – The City provides a comprehensive benefit package including employee medical, dental, and vision. Additionally, the City offers a cafeteria plan to employees and currently provides a monthly contribution based on the selected tier of coverage. (2020 monthly allowances are \$644.23 for employee only; \$1,218.43 for employee + one; \$1,608.13 for employee + family)

**Flexible Spending Accounts** – Max contribution is \$2,600 for health care and \$5,000 for dependent care per year. Grace period to incur expenses is March 15 of the following calendar year. Run out period to submit claims is June 15 in the same following calendar year.

**Deferred Compensation (Employer Paid)** – Negotiable.

**Life Insurance** – 2x annual salary up to \$350,000 (\$300,000 guaranteed issue); for the additional \$50,000, a health questionnaire is required. Plus \$250,000 individual term life policy through The Standard.

**Long Term Disability (Standard Insurance)** – Provided by the City.

**Administrative Leave** – 96 hours annually; 50% credited 1/1 and 50% 7/1. Any unused leave at the end of the calendar year shall be placed into a Retirement Health Savings Plan according to City rules, and any remaining balance paid out in cash (non-pensionable wages).

**Bereavement Leave** – 5 days of paid leave for immediate family or stepfamily; max 40 hours/incident. 9 hours may be granted on basis of blood relationship or marriage.

**Auto Allowance** – Negotiable.



**Vacation Leave** – Employees accrue vacation based on years of service with a maximum accrual cap of 2.5x the annual accrual amount. (Annual accrual rates are 0-3 years=140 hours; 4-9 years=160 hours; 10+years=180 hours) Additionally, employees are offered the ability to cash out vacation leave time on an annual basis

**Holidays** – Twelve (12) eight-hour (8 hour) paid holidays. Additionally, two (2) eight-hour (8) floating holidays are provided with 50% credited 1/1 and 50% 7/1.

## TO APPLY

If you are interested in this outstanding opportunity, please visit our website at [www.bobmurrayassoc.com](http://www.bobmurrayassoc.com) to apply online.

**Filing Deadline:  
May 8, 2020**

Following the closing date, resumes will be screened according to the qualifications outlined above. The most qualified candidates will be invited to personal interviews with Bob Murray and Associates. Finalist interviews will be held with the City of San Clemente. References will be contacted only following candidate approval.

If you have any questions, please do not hesitate to call Mr. Gary Phillips at:

(916) 784-9080



PROPOSAL

# City of Menlo Park

## Executive Recruitment Services for City Manager

Due Date: August 6, 2021

5:00 P.M. PST

SUBMITTED BY:

MELISSA ASHER

*Sr. Practice Leader, Products and Services*

CPS HR Consulting  
2450 Del Paso Road, Suite 220  
Sacramento, CA 95834  
P: 916-471-3358  
masher@cpshr.us  
Tax ID: 68-0067209

[www.cpshr.us](http://www.cpshr.us)

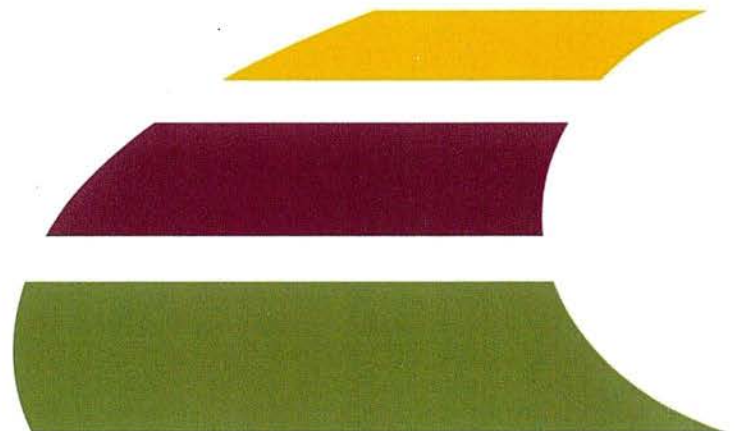

Your Path to Performance

August 6, 2021

Nira Doherty  
City Attorney  
City of Menlo Park  
701 Laurel St.  
Menlo Park, CA 94025

***Electronic Copy Submitted via email to: [ndoherty@bwslaw.com](mailto:ndoherty@bwslaw.com)***

**Subject: Executive Recruitment for City Manager**

Dear Ms. Doherty:

CPS HR Consulting (CPS HR) is pleased to have the opportunity to submit a proposal to assist the City of Menlo Park (City) with the recruitment of a new City Manager. We are uniquely qualified to undertake this effort as we have vast experience in assisting public agencies with executive search, screening, and placement.

We understand that each agency is unique, and our extensive experience allows us to tailor our process to specifically meet your needs. Our work with local government agencies throughout the United States gives us an in-depth understanding of government operations, programs, and services.

CPS HR offers a broad spectrum of human resource services while delivering personalized, results-oriented services, utilizing best practice methods of recruitment and selection strategies from our team of recruitment experts. Each recruitment is an opportunity to shape and prepare your organization for the future. We understand how important this transition is for you and are perfectly placed to assist you in this endeavor. Once this project begins, we will work with the City to tailor our process to highlight this exciting opportunity and attract the best possible candidates.

It is our commitment to work in partnership with your organization to a successful result.

Thank you for the opportunity to be considered for this assignment. Should you have questions or comments about the information presented in this proposal, **please contact me at [masher@cpsshr.us](mailto:masher@cpsshr.us) or (916) 471-3358.**

Sincerely,



Melissa Asher  
Senior Practice Leader, Products and Services



# Table of Contents

---

A. Detailed Timeline.....	1
B. Background Information.....	2
About CPS HR Consulting.....	2
Recruitment Experts.....	3
Diversity Outreach Process.....	5
Our Executive Recruiting Team.....	6
Team Biographies.....	6
References.....	8
Sample Work Products.....	9
Current Engagements.....	9
C. Proposed Schedule.....	10
Our Methodology and Approach.....	13
Key Stakeholder Involvement.....	13
City’s Needs.....	13
Commitment to Communication.....	13
Aggressive, Proactive, and Robust Recruitment.....	13
Hiring during the COVID-19 Pandemic.....	14
<b>Workplan/Scope of Work</b> .....	14
Phase I - Develop Candidate Profile and Recruitment Strategy.....	15
Phase II – Aggressive, Proactive, and Robust Recruitment.....	15
Phase III – Selection.....	17
D. Our Placement Guarantee.....	19
One-Year Guarantee.....	19
E. Additional Services.....	20
Stakeholder Engagement.....	20
Personality Inventory Assessment.....	20

F. Cost Proposal..... 21

    Professional Services..... 21

    Hourly Rate for Services Requested Outside of Scope ..... 21

Service Agreement & Insurance Acknowledgement ..... 22

Appendix A: Sample Work Products ..... 23

    Sample Brochure..... 23

    Sample Reference Report ..... 28

## A. Detailed Timeline

The project team CPS HR has selected is prepared to begin work upon receipt of a fully-executed contractual agreement. All search activities up to and including the selection of a new City Manager can be completed in 14 to 16 weeks. The precise schedule will depend on the placement of advertising on appropriate professional and affiliate websites, and the ability to schedule, as quickly as possible, the initial meeting. A proposed schedule of major milestones is presented below.

Task Name	Month 1				Month 2				Month 3				Month 4			
	1	2	3	4	5	6	7	8	9	10	11	12	13	14	15	16
Initial Meeting/ Candidate Profile	➤															
Draft Brochure		➤														
Brochure Approved/ Printed & Place Ads			➤													
Aggressive Recruiting							➤									
Final Filing Date							➤									
Preliminary Screening									➤							
Present Leading Candidates										➤						
Semi-finalist Interviews													➤			
Reference/ Background Checks														➤		
Final Interviews															➤	
Appointment																➤
<b>Weeks</b>	<b>1</b>	<b>2</b>	<b>3</b>	<b>4</b>	<b>5</b>	<b>6</b>	<b>7</b>	<b>8</b>	<b>9</b>	<b>10</b>	<b>11</b>	<b>12</b>	<b>13</b>	<b>14</b>	<b>15</b>	<b>16</b>

## B. Background Information

---

### About CPS HR Consulting

*CPS HR Consulting has been assisting organizations with their talent management needs for over 35 years.* We have unique expertise in delivering HR management and consulting services, employment testing, and assessment services to government agencies throughout North America. Our core competency is its knowledge of and expertise in the public sector.



CPS HR offers clients a comprehensive range of competitively priced services, all of which can be customized to meet your organization's specific needs. We are committed to supporting and developing strategic organizational leadership and human resource management in the public sector. We offer expertise in the areas of organizational strategy, recruitment and selection, training and development, and organization and workforce management.

CPS HR occupies a unique position among its competitors in the field of government consulting; as a Joint Powers Authority, whose charter mandates that we serve only public sector clients, we actively serve all government sectors including Federal, State, Local, Special Districts, Higher Education, and Non-Profit Organizations. This singular position provides CPS HR with a systemic and extensive understanding of how each government sector is inter-connected to each other and to their communities. That understanding, combined with our knowledge of public and private sector best practices, translates into meaningful and practical solutions for our clients' operational and business needs.

With more than 85 full-time employees as well as 200+ project consultants and technical experts nationwide, CPS HR delivers breakthrough solutions that help public sector organizations impact the communities they serve. CPS HR has worked with more than 1,200 government and public/non-profit clients throughout the United States and Canada.

Our headquarters are located in Sacramento, California. We have regional offices in Austin, TX; Littleton, CO; and Orange County, CA.

## Recruitment Experts

CPS HR specializes in the recruitment and selection of key professionals for cities, counties, special districts, and non-profits. Working in partnership with the governing body or selection team, we develop customized search strategies that focus on locating and recruiting qualified candidates who match the agency's unique needs. Our wealth of recruitment experience has been gained through *more than 19 years* of placing top and mid-level executives in public agencies throughout the United States.

- **Unmatched Recruitment Experience for Government Agencies.** CPS HR has extensive experience in recruiting executive-level professionals for public agencies across the United States. As a public agency ourselves, we understand how to work with and within government. Our understanding of public sector culture and policy uniquely sets us apart from our competitors.
- **Seasoned Executive Recruiters.** Our recruiters possess a high level of expertise in recruiting and placing executive-level professionals. Our staff of experts includes an exceptional group of full-time employees as well as a full complement of subject matter experts, intermittent employees, and part-time employees with a variety of public and private sector experience.
- **Detailed Needs Assessments.** We conduct a detailed needs assessment to identify 1) future organizational direction; 2) challenges facing the position; 3) the working style and organizational climate; and 4) required core and job specific competencies as well as personal and professional characteristics.
- **Success Recruiting Non-Job Seeking Talent.** We recognize that the very best candidates for some types of positions may not be looking for a career change, therefore, our recruitment team takes a very aggressive approach to identify and recruit such candidates.
- **Vast Pool of Public Agency Contacts.** CPS HR maintains a database of candidates and an extensive network of external resources to leverage for executive-level positions. We utilize our vast pool of public and non-profit contacts to deliver a strong list of competitive candidates who will be well prepared to assist you in the accomplishment of your specific mission and goals.
- **Satisfied Clients.** *Our executive search client satisfaction rating averages 4.6 on a scale of 5.* While many companies talk about client satisfaction, how many measure the impact of that through assessing client satisfaction by distributing written surveys and tying the results of these surveys to their performance management system? CPS HR Consulting does. A client satisfaction survey is sent at the end of every engagement requesting feedback on the quality of our staff, deliverables, and the overall consulting relationship.
- **Retention/Success Rate.** Our success rate is tied to the longevity of the candidates we place, currently more than 91% of our placements are still in their position after two years.

- **Partial list of recruitments.** Below is a brief listing of recent recruitments to show our experience with executive recruitments.

Agency	Title	Year Completed
County of Yolo (CA)	County Administrative Officer	Current
City of Surprise (AZ)	City Manager	Current
City of Columbia (MO)	City Manager	Current
City of Nogales (AZ)	City Manager	Current
City of Dickinson (TX)	City Manager	Current
City of Aztec (NM)	City Manager	Current
County of Los Alamos (NM)	County Manager	2021
City of Hercules (CA)	City Manager	2021
City of Clayton (CA)	City Manager	2021
City of Marysville (CA)	City Manager	2021
County of Yolo (CA)	Assistant County Administrative Officer	2021
County of Flathead (MT)	County Administrator	2021
City of Greeley (CO)	Deputy City Manager	2021
City of Reno (NV)	City Manager	2020
City of Bozeman (MT)	City Manager	2020
City of Richmond (CA)	City Manager	2019
City of Columbia (MO)	City Manager	2019
City of Union City (CA)	City Manager	2019
Town of Paradise Valley (AZ)	Town Manager	2019
City of East Palo Alto (CA)	City Manager	2019
City of Woodland Park (CO)	City Manager	2018
City of Modesto (CA)	City Manager	2018
Churchill County (NV)	County Manager	2018
City of Sacramento (CA)	Assistant City Manager	2018
County of San Luis Obispo (CA)	City Manager	2018
City of Goodyear (AZ)	City Manager	2018
County of Imperial (CA)	County Executive Officer	2018
Town of Oro Valley (AZ)	Town Manager	2017
Town of Los Gatos (CA)	Assistant Town Manager	2017
City of San Marino (CA)	City Manager	2017

---

***We possess broad experience working with the City of Menlo Park***

Since 1999 we have provided consistent services in the areas of employment testing (Sr. Account Clerk, Building Inspector, Accountant, Maintenance Worker, Clerical Positions, Analyst, Administrative Assistant, HR Technician), Law Enforcement and Public Safety testing, numerous trainings, employee engagement, a classification study, and multiple executive recruitments to include an Assistant City Manager in 2009. CPS HR recently contracted with the City of Menlo Park to conduct classification studies, to include the review and analysis of several positions. Additionally, as a result of the classification studies, CPS HR Consulting reviewed, revised, and developed classification specifications, as applicable.

---

## Diversity Outreach Process

CPS HR strives to attract the most highly qualified, diverse candidate pool possible. We are pleased that our diligent efforts have resulted in more than 51% of our executive level placements being minority and/or female candidates within the past three years. Our City Manager search for the City of East Palo Alto is an excellent example of our diverse outreach process. The City's demographics are 6% White, 16% Black, 4% Asian, 7% Pacific Islander, 64% Hispanic, and 3% Other. It was a high priority of the Mayor and City Council to pursue and demonstrate a diverse outreach process.

We accomplished this by advertising with organizations like the National Forum for Black Public Administrators and the Local Government Hispanic Network in order to reach these specific population groups. We also sought candidate referrals from local subject matter experts and the national leadership of groups like Women Leading Government. By taking the time to directly contact these influential industry experts, we ensured that we captured the maximum number of distinguished candidates – particularly those who are well-known in their industries, but who may not be actively looking for a new job.

The result was an incredibly diverse finalist group and our successful placement was an experienced Hispanic candidate. The elected officials were quite pleased with the process and end result. In fact, one Councilmember mentioned that he had checked with neighboring communities behind the scenes regarding their recent recruitments and could confirm that our candidate pool was most impressive in comparison – likely in terms of quantity, quality, and diversity.

## Our Executive Recruiting Team

CPS HR has assembled a strong project team with each member possessing extensive recruiting experience and a direct, in-depth understanding of local government. Your executive recruitment team will be Ms. Pam Derby, Mr. Andrew Nelson, and Ms. Paula Adams. They will work collectively to fulfill the City's needs in a timely and effective manner. We are committed to providing each of our clients the same level of service excellence, and we take great care not to take on more work than this commitment allows. **We will not utilize subcontractors for these services.** No staff members will be removed or replaced without the prior written concurrence of the City.

Role/Project Assignment	Name	Phone	Email
Manager, Executive Recruitment	Pamela Derby	(916) 471-3126	pderby@cpshr.us
Senior Executive Recruiter	Andrew Nelson	(916) 471-3329	anelson@cpshr.us
Executive Recruiter	Paula Adams	(916) 471-3350	padams@cpsr.us

## Team Biographies

### Pamela H. Derby, Manager, Executive Recruitment

Since joining CPS HR Consulting in 2003, Pam Derby has conducted a wide range of recruitments for county, city, special district and association executives including city attorney, executive director, general manager, city manager, assistant and deputy city manager, police chief, community and economic development director, human resource director, finance director, city administrator, registrar of voters, library director, and director of information technology in addition to specialized support positions.

Ms. Derby has just completed the City Manager recruitment for the City of Hercules and is currently engaged in City Manager recruitments for the cities of Surprise (AZ) and Columbia (MO) and the County Administrative Officer recruitment for the County of Yolo. The City of Columbia is a repeat engagement as Ms. Derby placed their current City Manager who is now retiring in January.

Prior to joining CPS HR, Ms. Derby served as the Aide to the Yuba County Board of Supervisors serving as the Board's liaison to County Department Heads, the community, and the media. This experience provided her with a unique perspective into the special circumstances that exist in a Board/Council-Manager relationship and a keen awareness of the inner workings of local government. She is sensitive to balance the wants of the community with the needs of the client so as to tailor a recruitment process that reaches out to the most appropriate candidates and ensures a diverse group of individuals from which to make a selection. She has successfully employed these techniques in jurisdictions ranging from under 10,000 to 10 million. Moreover,



she employs a firmly-held personal philosophy that candidates must be treated with the same respect and careful consideration as her client.

Prior to her local government service, Ms. Derby served in the private sector and with several non-profit lobbying associations. She was responsible for the management of several large consumer groups.

### **Andrew Nelson, Senior Executive Recruiter**

Andrew Nelson brings an extensive background in government service to his role as Executive Recruiter at CPS HR Consulting through city administration, transportation planning, and court management as well as professional recruiter training from the U.S. military.

Mr. Nelson has significant experience with recruitments of professional and management positions for the public sector. Prior to joining CPS HR Consulting, Mr. Nelson served as City Administrator for the City of Kemmerer, WY and as director of the Casper Area Metropolitan Planning Organization. This hands-on experience gives Mr. Nelson perspective to the mindset and needs of senior public officials recruiting open positions.

Beyond recruitment, his duties included comprehensive administration of their human resources policies. This consisted of assessing job performance, approving job descriptions and their associated revisions, revising employee policies, leading collective bargaining negotiations for the city, assessing and investigating risk management claims, and continuing training for all employees.

Additionally, Mr. Nelson currently serves the United States Coast Guard as an Auxiliary Recruiter. He received formal training in recruitment, including sales, marketing, and interviewing skills at the Coast Guard Training Center Cape May (New Jersey) and has received an Auxiliary Commandant Letter of Commendation and three Coast Guard Meritorious Team Commendations as a direct result of his recruiting efforts.

Mr. Nelson volunteers locally in the Las Vegas community as a career mentor for student members of the Association of Latino Professionals for America (ALPFA).

### **Paula Adams, Executive Recruiter**

Paula Adams brings over 25 years of public sector Human Resources experience with extensive managerial assignments as Human Resources Director and Director of Airports Administration with the City of Los Angeles.

Ms. Adams is well known for thinking strategically, contributing a constructive point of view, dissecting organizational barriers and applying active listening. Ms. Adams has been a leader on

a few strategic planning design teams and held a leadership role with organizational cultural shifting to foster diversity and inclusion in the workplace.

For 21 years, Ms. Adams had a leadership role for Los Angeles World Airports (LAWA), one of the largest airport complexes in the world. As an established and credible leader with Human Resources – Ms. Adams led recruitments for Deputy Executive Director, Assistant Airport Police Chief, Airport Police Chief, and Chief Financial Officer at LAWA.

Ms. Adams holds a Master of Public Administration from CSU Dominguez Hills and a Certificate in Corporate Litigation from UCLA Extension and serves on the Board of Directors of the Western Region International Public Management Association for Human Resources (WRIPMA) and is the 2021-2022 WRIPMA President.

## References

Provided below is a partial list of clients we have recently worked with in providing similar executive recruitment services. We are confident that these public-sector clients will tout our responsiveness and ability to successfully place candidates that were a good fit for their organization's needs.

CLIENT/POSITIONS	CONTACT(S)
<b>City of Hercules</b> 111 Civic Drive Hercules, CA 94547  City Manager (2021)	Steven Falk, Interim City Manager (510) 799-8216 Sfalk@ci.hercules.ca.us
<b>City of Marysville</b> 526 C Street Marysville, CA 95901  City Manager (2021)	Chris Branscum, Mayor (530) 812-2260 cbranscum@marysville.ca.us
<b>City of Clayton</b> 6000 Heritage Trail Clayton, CA 94517  City Manager (2020)	Julie Pierce, Vice Mayor (925)518-4446 jppierce@ci.clayton.ca.us

## Sample Work Products

Sample work products including a recruiting brochure and candidate reference report are available at the end of the proposal as **Appendix A** for the City's review.

## Current Engagements

Our recruiters are generally responsible for six to eight recruitments at any given time, depending on close and kick off times. Each recruitment is treated with equal importance, regardless of the size of the city or the type of recruitment. We are committed to providing each of our clients the same level of service excellence, and we take great care not to take on more work than this commitment allows. We will not utilize subcontractors for these services. Our recruitment team has the capacity and expertise to take on the City of Menlo Park, City Manager recruitment.

## C. Proposed Schedule

**CITY OF MENLO PARK  
CITY MANAGER RECRUITMENT  
POSSIBLE WORK PLAN/SCHEDULE**

Timeframe	Activity
<b>KICK-OFF MEETING</b>	
Week of 8/23	Consultant will meet with Council members to discuss Ideal Candidate attributes and recruitment process.
<b>STAKEHOLDER ENGAGEMENT</b>	
Week of 8/30	Consultant conducts Stakeholder/Community Engagement activities as directed by City Council.
<b>RECRUITMENT MATERIALS</b>	
9/7	<u>Recruitment Brochure:</u> <ul style="list-style-type: none"> <li>▪ Consultant submits recruitment brochure text for review.</li> </ul>
9/10	<ul style="list-style-type: none"> <li>▪ City submits final revisions to recruitment brochure text.</li> <li>▪ Consultant prepares recruitment and advertising materials.</li> </ul>
<b>ACTIVE RECRUITMENT</b>	
9/13	<u>Marketing:</u> Consultant posts the job opening to various websites and publications including: ICMA, Public CEO, California City News, Western City, National Forum for Black Public Administrators, Local Government Hispanic Network, Women Leading in Government, LinkedIn and governmentjobs.  Consultant sends initial e-mail blast to more than 5,500 potential candidates and referral sources around the country.

Timeframe	Activity
9/13 – 10/18	<p><u>Aggressive Outreach/Application Process</u>: Consultant follows up with targeted/qualified candidates (those who are a match to the candidate profile) to ascertain interest and encourage application. Candidates apply through the CPS HR website, receipt of applicant materials acknowledged. The Consultant vets candidate resumes against minimum qualifications.</p> <p>Consultant provides weekly updates to City staff regarding recruitment activities.</p>
<b>SELECTION ACTIVITIES</b>	
10/18 – 10/22	<p><u>Screening Interviews</u>: Consultant conducts comprehensive screening interviews with all candidates who meet the minimum qualifications as described in the job announcement. Consultant will also conduct media checks on all screened candidates.</p>
10/26	<p><u>Client Report Meeting w/City Council</u>: City Council will review the Consultant's recommendations regarding top candidates; determine the short-list candidates to be assessed by interview panels (make-up to be determined).</p> <p>Client Reports will be delivered electronically ahead of time for review prior to scheduled meeting.</p>
Week of 11/8	<p><u>Semi-finalist Interviews</u>: Interview short-listed candidates and determine finalists for further consideration. Selection process to be determined. Examples may include panels of department heads, subject matter experts and community members.</p> <p>Consultant prepares all materials, coordinates candidate logistics and assists with facilitation of the short-listed candidate interviews.</p>

Timeframe	Activity
Completed 3-5 days post semi-finalist interviews	<p><u>Reference/Assessment Activities:</u> Consultant conducts reference checks on the finalist candidates. Finalist candidates will participate in any pre-determined assessment exercises, i.e., leadership assessment, creation of staff report and presentation, etc.</p> <p>Consultant prepares all materials and coordinates any assessment activities.</p>
11/23	<p><u>Final Interviews:</u> City Council conducts interviews with finalist candidates and provides direction to Consultant and staff regarding next steps. Other assessment and candidate activities TBD.</p> <p>Consultant prepares all materials, coordinates candidate logistics and assists with facilitation of the finalist candidate interviews.</p>
<b>NEGOTIATION OF OFFER/BACKGROUND CHECK/APPOINTMENT</b>	
Following final Interviews	Consultant available to negotiate a compensation package offer and terms and conditions of employment with the selected candidate and conduct background check.
12/14	<u>Appointment:</u> City Council approves Employment Agreement.

## Our Methodology and Approach

---

### Key Stakeholder Involvement

The City Council on behalf of the City of Menlo Park must be intimately involved in the search for a new City Manager. Our approach assumes their direct participation in key phases of the search process. At the discretion of the City Council, other key stakeholders may also be invited to provide input for the development of the candidate profile.

### City's Needs

A critical first step in a successful executive search is for the City Council to define the professional and personal qualities required of the City Manager. CPS HR has developed a very effective process that will permit the City Council to clarify the preferred future direction for the City; the specific challenges the City is likely to face in achieving this future direction; the working style and organizational climate the City Council wishes to establish with the City Manager; and ultimately, the professional and personal qualities required of the City Manager.

### Commitment to Communication

Throughout the recruitment process, we are strongly committed to keeping you fully informed of our progress. We will collaborate with you to provide updates on the status of the recruitment via your preferred method of communication (phone conference, email, etc.).

We place the highest level of importance on customer service and responding in a timely manner to all client and candidate inquiries. Our previous clients and candidates have expressed a sincere appreciation for our level of service and responsiveness to the management of the recruitment process. As a result, we have many long-term relationships with clients that have led to opportunities to assist them with multiple recruitments.

CPS HR's communication continues once you have selected the new City Manager. We will contact the City Council and the newly appointed City Manager within six months of appointment to ensure an effective transition has occurred.

### Aggressive, Proactive, and Robust Recruitment

We take an aggressive approach in identifying and recruiting the best available candidates. There are those candidates who would gladly rise to the professional challenge and apply for this position; however, some of the best candidates are often not actively seeking a new position and may only consider a change once we present them with your opportunity. Evoking the sense of vision and opportunity in qualified persons is among the responsibilities of CPS HR, and we pride ourselves in our efforts to reach the best available potential candidates. We use advertisements, directly email the outreach brochure, post messages and connect with potential candidates on business media such as LinkedIn, and of course, pick up the phone and call qualified individuals and referral sources.

## Hiring during the COVID-19 Pandemic

Long before COVID-19 came into the common vernacular, CPS HR was engaged in a digital transformation to modernize and retool our services to provide remote support to our clients. Our standard platform is Microsoft Teams™, where we collaborate with our team members and even client staff to ensure a seamless flow of information. This investment has paid dividends during the remote working revolution over the last six months. We have not observed a decrease in the quality of the recruitment and selection process for our clients, and an overwhelming majority of clients have made hires using only our interview process conducted through Microsoft Teams™.

Several good examples of success are our recent City Manager recruitments for Bozeman, Montana and Reno, Nevada. CPS HR conducted the recruitments during COVID-19, and City Council members were able to interview each candidate and feel comfortable about reaching a consensus on a final selection using only the virtual environment without ever having met the candidate.

We are also able to adapt to other technologies and protocols that the client may have. Because our staff has been working remotely for several years, we are extremely flexible and can meet your needs according to your level of comfort and security.

## Workplan/Scope of Work

Our proposed executive search process is designed to provide the City with the full range of services required to ensure the ultimate selection of a new City Manager uniquely suited to the City's needs.



**Phase I:** Our consultant will meet with the City Council to ascertain the City's needs and ideal candidate attributes, to target our search efforts, and maximize candidate fit with the City.

**Phase II:** The recruitment process is tailored to fit the City's specific wants and needs, with targeted advertising, combined with contacts with qualified individuals from our extensive database.

**Phase III:** The selection process is customized for the City. CPS HR will work with the City Council to determine the process best suited to the City of Menlo Park.



## Phase I - Develop Candidate Profile and Recruitment Strategy

**Task 1 - Review and Finalize Executive Search Process and Schedule**

**Task 2 - Key Stakeholder Meetings**

**Task 3 - Candidate Profile and Recruitment Strategy Development**

**Task 4 – Develop Recruitment Brochure**

The first step in this engagement is a thorough review of the City's needs, culture and goals; the executive search process; and the schedule. CPS HR is prepared to meet with key stakeholders to obtain input in developing the ideal candidate profile and to assist us in understanding key issues and challenges that will face a new City Manager. Activities will include:

- Identifying key priorities for the new City Manager and the conditions and challenges likely to be encountered in achieving these priorities.
- Describing the type of working relationship the City Council wishes to establish with the City Manager.
- Generating lists of specific competencies, experiences, and personal attributes needed by the new City Manager in light of the discussions above.
- Discussing recruitment and selection strategies for the City Council's consideration to best produce the intended results.

CPS HR will provide a summary to the City stemming from these activities as an additional source of information for developing the candidate profile and selection criteria.

Following the completion of the workshop session, CPS HR will work with a professional graphic artist to design a recruitment brochure and present it to the City for review. Please refer to **Appendix A** for a sample brochure. Additional brochure examples are available on our website at [www.cps hr.us/search](http://www.cps hr.us/search).

## Phase II – Aggressive, Proactive, and Robust Recruitment

**Task 1 – Place Advertisements**

**Task 2 - Identify and Contact Potential Candidates**

**Task 3 – Resume Review and Screening Interviews**

**Task 4 – City Council Selects Finalists**

The recruitment process is tailored to fit the City's specific wants and needs, with targeted advertising, combined with personal contacts with qualified individuals from our extensive database.

CPS HR will prepare, submit for your approval, and publish advertisements on professional and affiliate websites to attract candidates on a nationwide, regional, local or targeted basis based on the recruitment strategy. Examples may include:

Advertising Sources	
<ul style="list-style-type: none"><li>Public CEO</li><li>ICMA</li><li>LinkedIn</li><li>Governmentjobs.com</li><li>League of California Cities</li><li>California City News</li><li>National League of Cities</li></ul>	<ul style="list-style-type: none"><li>Engaging Local Government Leaders</li><li>Careers in Government</li><li>Associations dedicated to sourcing candidates of diverse backgrounds</li><li>Municipal Management Association Northern California/Southern California</li><li>California City Municipal Foundation</li></ul>

As a consulting firm that interacts with hundreds of public sector executives during engagements, we have a cadre of individuals who we inform of recruitments, both to increase the visibility of the opening and to attract appropriate individuals who fit the special needs of our client. Communication with these professionals ensures that an accurate picture of the requirements of the job is apparent and proliferated throughout their professional networks.

*CPS HR is focused on reaching a diverse candidate pool* and would recommend publications/websites that are targeted to minority and female candidates. In addition to placing ads on websites aimed at minority candidates, we will contact leaders within appropriate associations to gain their insight and referrals of possible candidates.

***Within the past three years, more than 51% of our executive level placements have been minority and/or female candidates.***

CPS HR will prepare an email distribution list containing prospective candidates and referral sources. These individuals will receive a link to the City Manager brochure along with a personal invitation to contact CPS HR should they have any questions about the position.

CPS HR maintains a comprehensive, up-to-date database of industry leaders and experienced professionals; however, we do not rely solely upon our current database. We also conduct research to target individuals relevant to your specific needs and expectations to ensure that we are thorough in our efforts to market this position to the appropriate audience and to garner a diverse and quality pool of candidates.

We will:

- Convey a strong sense of the purpose and strategy of the City. For many talented individuals, understanding these aspects is one of the key motivators to compete in such an environment.

- Provide guidance and resources to candidates regarding the area's cost of living, mean and median housing prices, higher education opportunities, K-12 education information, and other aspects of interest to those who are considering relocating to the area.
- Actively seek highly qualified candidates who may be attracted by the prospect of collaboration with other departments, providing exceptional leadership to the City or continuing to ensure the public confidence in the integrity of the City.

CPS HR will directly receive and initially screen all resumes. This screening process is specifically designed to assess the personal and professional attributes the City is seeking and will include a thorough review of each candidate's resume, and if applicable, supplemental questionnaire responses and other supporting materials. CPS HR will personally speak to selected candidates during a preliminary screening interview and will spend extensive time ascertaining each candidate's long-term career goals and reasons why the candidate is seeking this opportunity, as well as gaining a solid understanding of the candidate's technical competence and management philosophy. We will gather data on any other unique aspects specific to this recruitment based upon the candidate profile, as well as conduct internet research on each candidate interviewed.

CPS HR will prepare a written report that summarizes the results of the recruitment process and recommends candidates for further consideration by the City Council. Typically, the report will recommend five to eight highly qualified candidates and will include resumes and a profile on each interviewee's background. CPS HR will meet with the City Council to review this report and to assist them in selecting a group of finalists for further evaluation.

### Phase III – Selection

**Task 1 - Design Selection Process**

**Task 2 - Administer Selection Process**

**Task 3 – Final Preparation for Appointment**

**Task 4 – Contract Negotiation (if requested)**

CPS HR will design a draft selection process based on information gathered in Phase I. We will meet with the City to review this process and discuss the City's preferred approach in assessing the final candidates. The selection process will typically include an in-depth interview with each candidate but may also include other selection assessments such as an oral presentation, preparation of written materials, and/or problem-solving exercises.

We will coordinate all aspects of the selection process for the City. This includes preparing appropriate materials such as interview questions, evaluation manuals, and other assessment exercises; facilitating the interviews; assisting the City with deliberation of the results; and contacting both successful and unsuccessful candidates.

Following the completion of the selection process, CPS HR will be available to complete the following components:

- **Arrange Follow-up Interviews/Final Assessment Process:** Should the City wish to arrange follow-up interviews and/or conduct a final assessment in order to make a selection, CPS HR will coordinate this effort.
- **Conduct In-Depth Reference Checks:** The in-depth reference checks are a comprehensive 360-degree evaluation process whereby we speak with current and previous supervisors, peers, and direct reports. (It is our policy to not contact current supervisors until a job offer is made, contingent upon that reference being successfully completed, so as not to jeopardize the candidates' current employment situation.) Candidates are requested to provide a minimum of five references. CPS HR is able to ascertain significant, detailed information from reference sources due to our commitment to each individual of confidentiality, which leads to a willingness to have an open and candid discussion and results in the best appointment for the City. A written (anonymous) summary of the reference checks is provided to the City.
- **Conduct Background Checks:** Upon a conditional job offer, we will arrange for a background check of a candidate's records on driving, criminal and civil court, credit history, education, published news, and other sensitive items. Should any negative or questionable content appear during these checks, CPS HR will have a thorough discussion with the finalist(s) and will present a full picture of the situation to the City for further review.
- **Contract Negotiation (if requested):** Successful negotiations are critically important, and we are available to serve as your representative in this process. With our expertise, we can advise you regarding current approaches to various components of an employment package. We can represent your interests with regards to salary, benefits, employment agreements, housing, relocation, and other aspects, with the ultimate goal of securing your chosen candidate.

## D. Our Placement Guarantee

---

### One-Year Guarantee

If the employment of the candidate selected and appointed by the City as a result of a full executive recruitment (Phases I, II, and III) comes to an end before the completion of the first year of service, CPS HR will provide the City with professional services to appoint a replacement. Professional consulting services will be provided at no cost. The City would be responsible only for expenses such as re-advertising, consultant travel, additional background checks, etc. **This guarantee does not apply to situations in which the successful candidate is promoted or re-assigned within the organization during the one-year period.** Additionally, should the initial recruitment efforts not result in a successful appointment, CPS HR will extend the aggressive recruiting efforts and screen qualified candidates until an offer is made and accepted. CPS HR does not provide a guarantee for candidates placed as a result of a partial recruitment effort.

## E. Additional Services

---

### Stakeholder Engagement

The City Council may desire input from residents, stakeholder groups, employees, etc. To accomplish this task, we have deployed several strategies to gather feedback including community meetings, online surveys, roundtable/visioning meetings, and teleconferences. An example of the breadth this process can take is our recent recruitment for the City Manager of Columbia, Missouri. Over the course of one week, our team met with over 75 community stakeholders and groups identified by the City Council, held two public meetings, and issued a public survey on the recruitment that obtained over 450 responses. This information was compiled into a comprehensive report and presented to the City Council. This information was used to create marketing materials and will inform our creation of appropriate applicant screening processes. This kind of engagement is standard for CPS HR and is included in our professional fee.

### Personality Inventory Assessment

In order to measure candidates' attitude, motivation, and personality, the City Council may wish to consider the use of a personality inventory. CPS HR has a unique relationship with Hogan Assessment Systems to provide its products to the government sector. As an international authority in personality assessment, Hogan has over 30 years of experience helping agencies evaluate leadership potential. Hogan's Leadership Forecast Potential Report, for example, outlines an individual's day-to-day leadership style, including behavioral descriptions and leadership competencies in terms of seven dimensions of normal personality that address a different component of leadership performance. In addition to being informative about individuals' attitude, motivation, and personality, these personality measures are also highly reliable in terms of their prediction for successful job performance. These optional reports are priced from \$150 - \$450 per candidate based on the suite of assessments chosen.

## F. Cost Proposal

---

### Professional Services

Our professional fixed fee covers all CPS HR services and deliverables associated with **Phases I, II, and III** of the recruitment process.

Travel expenses for candidates who are invited forward in the interview process are not included in our current price proposal. However, should the City desire CPS HR's Travel Team to assist with these arrangements, we are happy to do so. This might require an amount be added to our contract.

Professional Fixed Fee	
Professional Services for Full Recruitment (Fixed Flat Fee)	\$25,000

*\*Professional fees would be billed and paid monthly.*

### Hourly Rate for Services Requested Outside of Scope

Executive Search services are based on an hourly rate of \$125/per hour, however, we pride ourselves on our flexibility and are typically able to accommodate any client requests within our flat fee arrangement.

### Optional: Recruitment Video

In addition to the standard recruitment brochure, CPS HR can develop a recruitment video to attract a wider range of applicants. More than 63% of organizations are now using visual media to attract the attention of job seekers, convey the culture of the organization, and effectively expand the talent pool. When comparing searches that include a video with searches that do not include a video, our data indicates that those with a video garner over 40% more applications. For this approximately three-minute video, CPS HR will arrive onsite to film footage of the workplace and community, as well as conduct onsite interviews with selected employees. This video is optional and costs **\$3,500**.

## Service Agreement & Insurance Acknowledgement

---

The CPS HR Contracts Manager has reviewed the contract and insurance agreement information included in the RFP. We can accept the terms and conditions set forth in it with **two minor exceptions** in which we respectfully request and hope the City is amenable to discussion of this language during contract negotiations.

1. CPS HR does not own any vehicles, there is not coverage for “owned” autos.
2. Our self-insured retention is \$50,000.



*We thank you for your consideration of our proposal. We are committed to providing high quality and expert solutions and look forward to partnering with the City of Menlo Park in this important endeavor.*



## Appendix A: Sample Work Products

---

### Sample Brochure

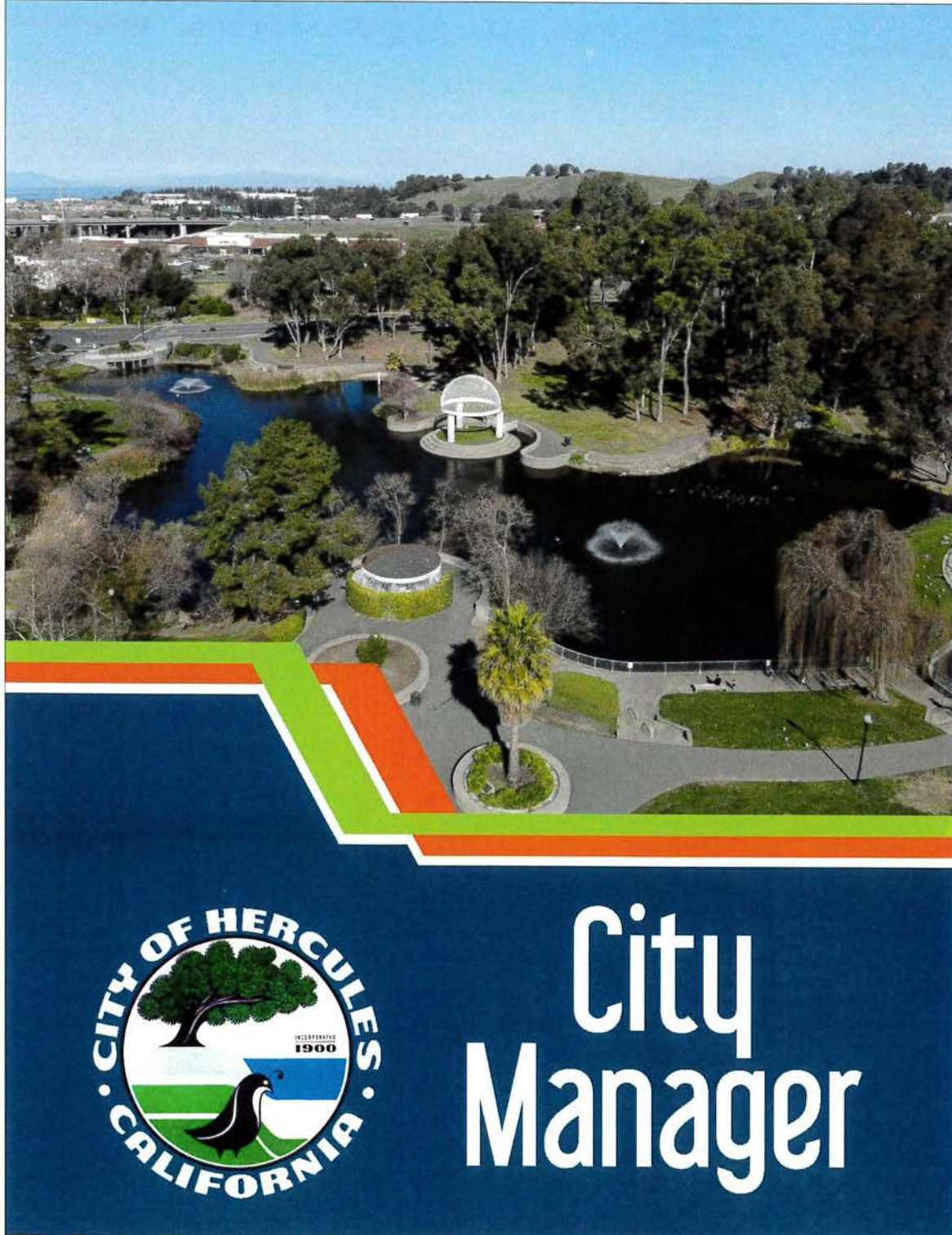

## BECOME PART OF A COMMUNITY

Established as a dynamite factory in the 1800s and incorporated in 1900, the City of Hercules sits on the northeastern shore of San Pablo Bay, conveniently located along the I-80 corridor and a half-hour drive to both San Francisco and Napa. The 26,500 residents represent a diverse mix of many ethnic groups. Primarily a suburban, family-oriented community, the City has bold plans for a growing town center, a lively new waterfront, and a new train and ferry terminal.

Hercules offers residents a high level of municipal services for a small entity. The City provides a full range of recreational programs including youth/teen and adult activities, and year-round childcare. In the past the City hosted several major community events which attracted visitors from the regional area as well as local citizens, and the revival of these events is being considered. The City's Senior Center provides daily senior programs and activities and sponsors special community events and trips.

Hercules maintains an abundance of open space areas and trails throughout the community, offering the opportunity for spotting various types of wildlife and affording dazzling views of the bay. Hercules also has two community and five neighborhood parks. Refugio Valley Park comprises 66 acres and aligns with a walking trail to the City's Community Swim Center. The five neighborhood parks contain about 32 acres. The City also has approximately 950 acres of open space areas and trails distributed throughout the community. Together the open space areas and city parks account for approximately 1/3 of the total land area within the City. Future plans include redeveloping the historic Hercules Point as a public waterfront park.

Hercules is served by two public school districts: John Swett Unified School District and West Contra Costa Unified School District. Private elementary and secondary schools are also available in adjacent communities. At the post-secondary level, both public schools and private schools in the East Bay provide a variety of high-quality educational opportunities. The City Child Care Program provides before-and-after school day care and pre-school programs.

Hercules is served by two major transportation routes (Interstate 80 and State Route 4), San Pablo Avenue, which bisects the City, is part of the Historic Highway 40, the main artery into town prior to Interstate 80 being built. With recent new growth and regionally implemented growth management plans, future improvements to these transportation corridors are planned. While there are plans for future ferry and train service, Hercules currently has a BART owned Transit Center that offers a variety of transit options that help connect the City to the rest of the Bay Area including WestCat direct bus service to and from the Del Norte BART Station, the LYNX express bus service to and from San Francisco, and an active informal carpool/ride-sharing option.



## THE ORGANIZATION

The City operates under a Council-Manager form of government. The City Council consists of five members, elected at-large on a non-partisan basis, who serve staggered four-year terms. In December of each year, the City Council conducts a reorganization of the Council at which time the Mayor and Vice Mayor are appointed for one-year terms.

Hercules is a full-service city and provides services through five departments that include Administration, Community Development, Parks & Recreation, Police, and Public Works. Fire services are provided by the Rodeo-Hercules Fire Protection District. City-wide services are delivered with the assistance of 57 full-time staff and a General Fund budget of approximately \$16.8 million for FY 2020-21.

To learn more, go to: [www.ci.hercules.ca.us](http://www.ci.hercules.ca.us)



## Vision Statement

*"The City of Hercules is a richly diverse community, serving as a major transportation hub and a prime destination for the Bay Area. It is built on a sound economic and physical infrastructure, and its residents enjoy public safety, security, well-maintained parks, streets and public facilities. We conduct our work in an atmosphere of trust and respect. We constantly look for better ways to deliver services and always strive for excellence."*

As the City's Chief Executive Officer, the City Manager is responsible for ensuring the City organization is focused on meeting the Mission as defined in the Strategic Plan:

*Our mission is to lead our diverse community and enhance the quality of life in the City of Hercules, now and in the future. We do this by providing effective, efficient, responsive, and innovative services with integrity and a culture of transparency.*

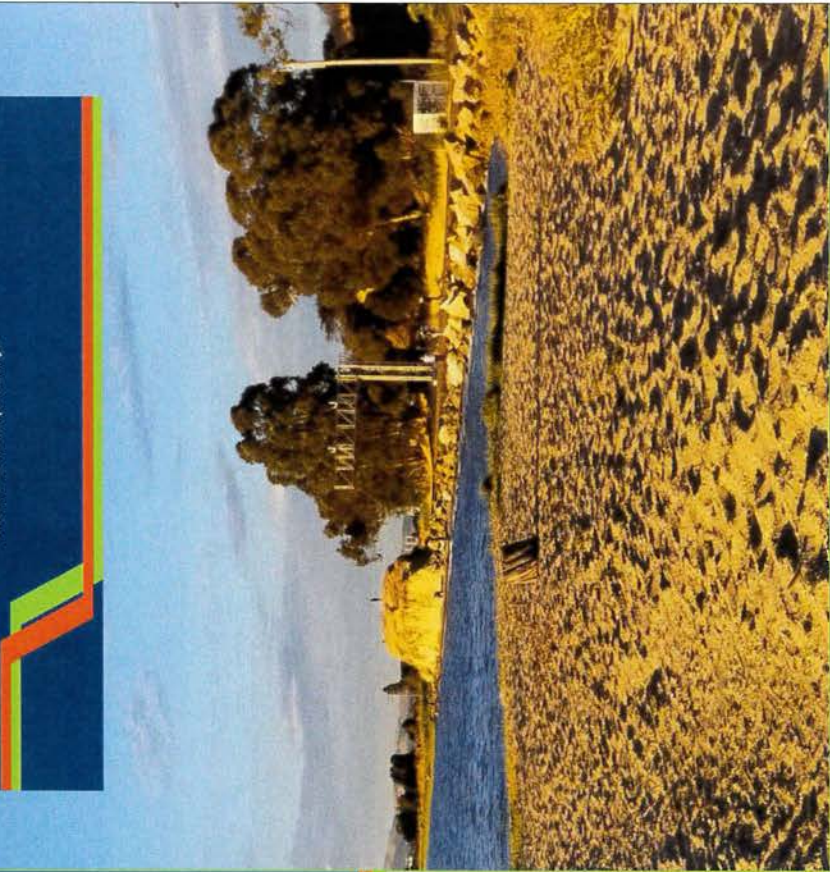

## OPPORTUNITIES

The FY2020-21 Budget outlined several key priorities for the City Manager including:

- » Identify and pursue grant opportunities for the Hercules Regional Intermodal Transit Center, including working with our regional partners, advancing the design of the next phases to ensure they are shovel ready, and building support for the project among key constituencies.
- » Ensure the successful build out of the Waterfront Master Plan and the Bayfront, including guiding the construction and entitlement components of each phase, forming the Waterfront Parking entity, developing the required affordable housing implementation agreement, and working with the developer to ensure the completion of a vibrant and successful transportation-oriented development.
- » Expand the City's tax base through new development, including the Safeway center (set to open in April 2021), the currently under construction Willow Avenue Auto Service and Self-Storage center, the Sycamore Crossing development including a hotel and retail components, the Hilltown residential project, and identifying and pursuing other opportunities such as the possible reuse of the Franklin Canyon Golf Course site.

## THE IDEAL CANDIDATE

The City Council is seeking an ethical, dedicated public servant who has integrity and fortitude, with strong finance skills, who embraces transparency and open government. The ideal candidate will:

- » Exhibit an engaging style and be an open, honest communicator willing to be available to the Council, community, and city stakeholders.
- » Bring considerable small-medium size city experience in order to embrace innovative strategies to provide an array of municipal services while dealing with the realities of municipal budget constraints.
- » Possess well-rounded city management skills and be comfortable in this small organization, hands-on role. You can be dealing with economic development, one moment, and transportation funding the next.
- » Be a good listener who knows when to listen, when to add perspective and when to tell the Council, 'no'.
- » Hit the ground running and not be afraid to jump in even if that means making a mistake.
- » Develop, maintain, and understand the importance of strong relationships with city corporate partners.
- » Believe in the city manager's leadership team and their ability to make and own their decisions.
- » Possess the political aptitude to anticipate issues of concern.
- » Help the City maintain focus in order to accomplish meaningful change and not lose momentum despite having various priorities.

## EDUCATION AND EXPERIENCE

The ideal candidate will possess no less than five (5) years of increasingly responsible experience performing complex budgetary, financial, policy, and organizational analysis duties. Experience working directly with an elected council or board is preferred. A Bachelor's degree in business, public administration, or a related field is expected, with a Master's degree preferred.



## COMPENSATION/BENEFITS

The salary range for the City Manager goes up to **\$250,000**, with starting salary dependent on qualifications and experience. The City offers an attractive benefit package that includes CalPERS retirement.

## APPLICATION AND SELECTION PROCEDURE

To be considered for this exceptional career opportunity, submit your résumé, cover letter, and a list of six work-related references (two supervisors, two direct reports, and two colleagues, who will **not** be contacted in the early stages of the process) by **Monday, May 10th**. Résumés should reflect years **and** months of employment, beginning/ending dates, as well as size of staff and budgets you have managed.

Please go to our website to submit your application: <https://www.cpshrus/recruitment/1776>

For further information contact:  
Pam Derby  
CPS HR Consulting  
(916) 263-1401  
E-mail: [pderby@cpshrus](mailto:pderby@cpshrus)  
Website: [www.cpshrus](http://www.cpshrus)

**CPS HR CONSULTING**

Resumes will be screened in relation to the criteria outlined in this brochure. Candidates with the most relevant qualifications will be given preliminary interviews by the consultants. Candidates deemed most qualified will be referred to the City Council. Selected candidates will be invited to participate in further interview and selection activities beginning the latter part of May. An appointment will be made following comprehensive reference and background checks.

## Sample Reference Report

**CITY MANAGER  
CITY OF XXX**

**REFERENCE CHECK SUMMARY**

**2014**

<b>Finalist Name</b>
----------------------

The following individuals were contacted as references in relation to NAME candidacy for the position of *City Manager*. The information received was obtained in confidence, therefore, is not attributable to any specific individual. In the interest of presenting a substantial amount of feedback in a concise manner, the information has been organized among key themes and comments that are consistent with the critical factors associated with the position.

**REFERENCES CONTACTED**  
*(Alphabetical order)*

**Name, Title, Agency:** She met NAME 6 years ago when NAME was hired in the Accounting department in XX County. REF has worked closely with her since NAME became the County CAO.

**Name, Title, Agency:** REF has known NAME for 2 years. He is one of 5 Supervisors that she currently reports to.

**Name, Title, Agency:** They both worked in XX County for government-run agencies. They were colleagues and networked on a regular basis. REF has known NAME for about 5 years.

**Name, Title, Agency:** REF has known NAME for 3 ½ years. He is one of 5 Supervisors that she currently reports to.

**Name, Title, Agency:** REF has known her for 5 years, when NAME came to XX County. REF was a department head at the time when NAME became the CAO. REF reported to her.

**Name, Title, Agency:** Lamont met NAME when he became the City Manager in Durham, NC in 1997. He worked with her until he left in 2002. Since then, they've kept in touch on a casual basis.

**Name, Title, Agency:** He has been the County's lawyer since she arrived in XX County in 2003. He was on the panel that hired her.

**Name, Title, Agency:** REF has known NAME since 1995. They worked together for 3 years in Durham between 1998 - 2001 (she was the Budget Director and he was a Senior Analyst). Prior to their time in Durham, they were professional colleagues. Since he's left Durham, they've stayed in touch.

**Name, Title, Agency:** REF came to the Board in XX County in 2005, she met NAME then. They work together on some projects with relation to the County.

**Name, Title, Agency:** He was hired by the Board of Supervisors to assist with development services and to be the interim Assistant CAO. He reports to NAME as a Consultant.

**Name, Title, Agency:** They were introduced 4 ½ years ago when she was appointed as the CAO in XX County. He previously worked for XX County but has been gone about 3-4 months. They talk on occasion.

#### Overall Impressions

- NAME stepped up to the plate and became the new CAO shortly after she arrived. She embraced the role, even though it was a very challenging situation. She lacked some experience at the time, XX County was a learning experience for her. It's a big county with huge diversity and she's been embraced by the community.
- She's extremely funny and very fun to work with. She throws her heart and soul into her job.
- She has potential for even more growth, she's still on a learning curve.
- She's very creative, which comes from her city government experience; she has a lot of ideas regarding new programs. She's learned a great deal about California and labor laws since she arrived in XX. She's very comfortable with city government.
- Extremely smart, intelligent and thoughtful.
- XX County is a challenging place to work and she took on the job with little or no exposure to California rules and regulations. She brought a sense of stability and comfort to the organization without playing power politics.
- Solid, terrific experience. She has a calm demeanor about her even if she's juggling multiple issues. She understands what is being said and what isn't being said. She has maintained her professionalism during some difficult situations.
- She's very dynamic, energetic and an extremely bright young woman.
- Very detail-oriented.
- She is very calm and keeps an even keel even while other people are losing their focus. She keeps her eye on the ball.
- She came to XX during a tumultuous time and she brought calm to the organization and proceeded with an even course.
- Exceptional hard worker who has great attention to detail. Smart, thoughtful and analytical. Gets along well with people, great interpersonal skills. She is a lot of fun.

- Her longevity is a testament to her endurance. She has tenacity and a fighting personality. She's very good at the political and technical issues. Her relationships are strong in the area.
- She is very capable.
- She is efficient, tends to take on too much herself. Doesn't think she's been given everything she needs to succeed.
- She embraces learning and reaches out to other jurisdictions for feedback.
- She does a great job.
- Very responsive regarding issues and concerns. She brings in a different perspective. She's honest, whether the Board wants to hear it or not.
- NAME is very thorough. She has had challenges and has kept her composure throughout the process. She should be rewarded for her hard work.

#### **Integrity**

- Beautiful integrity. She has a mannerism about her that draws people in but she's tough when she needs to be.
- Very high integrity. She doesn't play "underground", she has direct communication. She always encourages honesty and she gives that in return. If she has a concern, the individual will know immediately in clear terms.
- She is the complete package; this is one of her greatest strengths. Everybody trusts her judgment.
- Beyond reproach. She helped uncover numerous challenges in the structure of the city. Through each challenge she used her moral judgment and professionalism. Very ethical.
- Very good integrity, never any questions about her. Everybody likes her, even those who have differences with her.
- Outstanding. She brings calm to chaos. Her work products are always thoughtful and highly credible. She's very committed to doing things the right way.
- Very strong, she isn't someone who says one thing and does another. She wears her heart on her sleeve.
- Very high integrity. She presents "truth in advertising", she lays out the issues and puts forth recommendations. She has no hidden agenda and is not manipulative.
- Never questioned.
- Nothing negative.
- Excellent, nothing negative.

#### **Technical Competence**

- This is her biggest strength. She managed 37 department heads and is a wiz at the budget. She has gotten her budget passed every year, even if the Board doesn't always follow her advice. She has made tough decisions and this reference supported her.

- She is well-versed in budget policy and has a good handle on California issues now. She has adopted a strategic plan and developed performance measures that are working effectively. She created a number of employee focused task groups regarding communication and customer service.
- She came in with a strong financial base but also understands land use, enterprise, community and labor issues. She doesn't shy away from capital projects and is very collaborative with other agency leaders.
- This is her greatest strength; she's very adept at finances.
- Her strength is her budget skills.
- She has good organizational theory experience; she understands how an organization works.
- She's been focused on policy and she managed to bring a 5% reserve and a 3% contingency, which was never accomplished before.
- She has extraordinary technical skills, she knows the budget very well and knows how they're created. She advocates goals, objectives and measures of performance.
- Her oversight is good, she knows what needs to be done. Good navigation of political personalities is better than most, not as good as some.
- Her strength is the budget.
- She's great with the budget.

#### **Work Ethic**

- She's always there, a bit of a die hard. However, doing well at balancing her home/work life.
- She has a family and had a baby since she joined XX County. She was on maternity leave during the budget time and she returned immediately to jump right back in. She's always on top of things.
- She always gets her work done and moves the county forward even when that didn't seem possible.
- Very hard worker.
- She has a strong commitment to getting things right.
- She's very high energy, a firehouse who is present and isn't missing in action.
- NAME works very hard, she only took 6 weeks of maternity leave.
- Always works hard.
- Available 24/7, comes in early and leaves late.
- Extremely dependable.

#### **Managerial style/abilities**

- She has had the opportunity to meet and overcome challenges in dealing with elected officials in her current role. Given the opportunity and authority to manage on her own, she would grow tremendously.



- She has an informal, direct style. She talks in a no-nonsense language and doesn't create barriers between herself and staff. She's inclusive and gets input from everyone.
- Has created a collaborative atmosphere in XX County. She welcomes dialogue with people. She enforces and implements vision.
- She manages by motivating people to move in a different direction if necessary. She is able to broaden their view. She is situational and reads the environment; she will nurture or be firm as needed. She is participative and includes others in decision making when it's appropriate.
- She manages well and has tried innovative things regarding the reorganization of the county. She is cooperative and collaborative without being heavy handed. She can be decisive when necessary.
- Uses informal style to give assignments and allows staff to run with it. Not a micromanager, she's more relaxed and delegates but very accessible and open to questions.
- She ranks among the best managers this reference has worked with. She empowers, delegates and trusts her staff.
- The system she worked in was somewhat unmanageable, but she made every effort to communicate. She implemented "CAO notes" which provided the Board and community with updates on a weekly basis.
- She has the respect of those who work for her.
- Hands-on and well prepared.
- Not aggressive, more participative. She involves her #2 and #3 people to help with big decisions.

**Ability to hold people accountable**

- She has a great relationship with the department heads, she does her job well.
- Her internal staff seems dedicated. This reference has had positive experiences with her.
- Definitely holds people accountable.
- This is one of her strengths. She doesn't allow people to let things go, she'll follow up and make sure the work gets done.
- She does this quite well.
- Absolutely. If targets weren't being hit, she'll let staff know. Always wanted to make sure the outcome matched the goals.
- She encourages people and infuses trust and an expectation of accountability.
- Some staff were let go and she assisted with getting things done including some items that slipped in the past.
- Believes so. Their system makes department heads limited in effecting corrective issues. She understands and works within parameters she's given.
- Definitely.

**Leadership Skills**

- She is a good leader and has the respect of many people in the county and the community.
- Strong leader but doesn't supersede the power of the Board. She clarifies and validates their expectations.
- She's very good at knowing when to be "on stage" and when to step off. She's a very capable leader.
- Her leadership style changes based on the needs of the individuals around her.
- She is solid but low key. She is very collaborative and works to get people together.
- Strong leader.
- She had credibility in the organization and knew how to motivate the team to accomplish their goals.
- One reference has spent 20 years in the public sector and places her in the top 1 or 2 leaders.
- She conveyed what she needed and kept the team together.
- She was a strong presence in the community. She entrenched long-term employees and is good at reaching down to all levels of people.
- Moderate to good. This reference isn't sure whether that's a product of her or the system she's currently in.
- She is good but she wants to be liked, not always possible in that role.
- Overall, she's a good leader. She understands people well enough to communicate what she wants done. When someone goes against her, she's not always forceful enough. She can get sucked into the drama of the environment.

**Communication Skills**

- Very good skills.
- She has an authentic and direct communication style.
- Excellent communication style
- She has a clear style both upward and downward. She is very inclusive.
- Gives good presentations. She has a friendly, conversational style.
- Excellent writer who can change her style depending on the circumstances. Friendly, positive, gets along with people.
- Very good; she is patient and listens.
- Uses all communication tools effectively.
- Moderate to good skills.
- Excellent, she sees the problem and goes right to the person. She's always presenting solutions along with the problems.

**Board/Council Relations**

- Strong relationship with the Board

- The Board has been impressed with her clarity of vision and she takes their direction. She doesn't insert herself as the authority over the department heads but she is clear on her role in carrying out the Board's wishes.
- Excellent dealing with the Board. Has a regular communication process with all the members and they support her. They've had a great deal of turnover and they've never lost confidence in her.
- She is very politically savvy.
- The Council had a high degree of faith in her. She has a good history of keeping them in the loop.
- She has good board presentation skills.
- They all like her. She has been challenged with being asked to take on a stronger role and not getting supported at times. However, she has persevered and maintained her role effectively.
- The council had a lot of confidence and respect for her.
- She is very good. Not everybody loves or hates her, she goes to them with important issues and they trust her judgment.
- Mostly successful given challenges in the area.
- Relationship is one of respect. The Board will be disenchanted if she leaves.

**Weaknesses/Detractors' Concerns**

- One reference would like to see her develop more in her ability to hold people accountable but feels she's capable.
- Given the opportunity to sink her teeth in, she'll be able to grow even more in her role.
- She tends to take on too much of everything, has a very full personal and work life. She is pressed to do more with less.
- Can't think of anything. She's kept the county moving forward and the reference doesn't know what else NAME could do to make it better.
- Tends to be a workaholic, has been told to go home. Very dedicated.
- She has worked in a challenging county and could have been a little more forceful in dealing with the management team. However, due to the structure of the county, she's done the best she could.
- Sometimes works too hard.
- Can become overly passionate about issues. She should remember to take a step back and see the big picture.
- She has a tendency to bring the council more financial issues, one reference would like to see her more balanced with regard to community development.
- She could be a little bit stronger and stand up for herself (wouldn't call it a flaw, but a result of the system she's in).
- Feels she could give more personal attention to leadership. Not in a groveling way, but more one-on-one would be helpful.
- Discipline would be the only area he could think of; she might be more forceful.

- Thing she worries the most is delegation. They haven't provided her with delegated responsibility (partly the Board's fault). Given the opportunity to delegate and having admin staff to back her up she would advance things faster.
- Could develop more from an operations standpoint, it's not her strongest quality.
- She's not always comfortable with confrontation or addressing people with problems directly.

**Summary Comments**

- NAME is fun-loving and creates a positive environment. She has an endearing quality to her that brings smiles to the staff and makes them feel good about what they do.
- She is extremely pleasant to work with. She's great at problem solving and working with conflict. Very strong at dealing with people with diverse issues.
- She has strong organizational skills in managing projects and tasks.
- The community would get a solid leader who is open, listens and willing to get out in the community to solicit feedback without getting ahead of the Council.
- She has an independent mind, she takes advice but then does what she thinks is right.
- They would be very sorry to see her go.
- She would make an outstanding City Manager. She can be underestimated due to her stature but she will drive the organization toward meeting their goals. She's particularly well-suited for a medium sized organization. Her style matches best where she can know all the players.
- City would gain a tremendous amount by bringing her on. She will mesh well with the personalities.
- She is a pleasant lady and a good person at her core. She has no malice or character flaws.
- She is more suited for a city position than with a county.
- City would be getting a great person.
- Thinks she would do a good job, they would miss her.



## PROPOSAL FOR CITY MANAGER CITY OF MENLO PARK

Submittal date: August 6, 2021

**Submitted by:**

Koff & Associates  
2835 Seventh Street  
Berkeley, CA 94710

**Frank Rojas**

Recruitment Manager

[frojas@koffassociates.com](mailto:frojas@koffassociates.com)

510.495.0448

KoffAssociates.com



Koff & Associates

A Gallagher Company



Koff & Associates  
A Gallagher Company

August 6, 2021

Nira Doherty  
City Attorney  
701 Laurel St.  
Menlo Park, CA 94025

Dear Ms. Doherty,

Thank you for the opportunity to submit a proposal to assist the City of Menlo Park with Executive Recruitment services for a new City Manager. It is our hope that this partnership may lead to the possibility of assisting with additional positions within the "Capital of Venture Capital." Koff & Associates (K&A) Recruiting, now a Gallagher company, is uniquely qualified based on over 37 years of assisting public agencies with finding and placing candidates who are dedicated to public service.

Our unique selling proposition lies in K&A Recruiting's experience supporting public sector clients in California and throughout the USA. Through our investment in modern recruitment technology, we offer forward-thinking services that not only provide for advanced extensive sourcing and outreach but allow us to tell the story of each project through easy-to-understand data. K&A Recruiting uses National Language Processing to remove bias from our job ads, creating diversity in candidate pools to build workforces that accurately represent the communities served.

Having conducted countless executive search efforts has made K&A Recruiting an expert in identifying, targeting, recruiting, and successfully placing women and minority candidates in many of our recruitments. Diversity recruiting is an area of focus, and our firm has a vast pool of resources at our fingertips to provide outreach on an industry-wide basis to the public and private sector for qualified candidates nationwide. We pride ourselves in transparency, flexibility, and quality work.

As K&A's Recruitment Manager, I am pleased to introduce Gary Palmer. Gary will be your Project Manager for all recruitment efforts with K&A Recruiting's support team. You can reach him at (510) 345-3954 or [gpalmer@koffassociates.com](mailto:gpalmer@koffassociates.com) or contact me at (510) 495-0448 or [frojas@koffassociates.com](mailto:frojas@koffassociates.com).

Sincerely,

Frank Rojas  
Recruitment Manager



## Table of Contents

---

Business Information	1
Experience and Qualifications	1
Recent Successful Recruitments	2
Project Team	4
Project Approach / Methodology	6
References	11
Pricing Proposal	12
Other: Insurance Considerations	14
Signature Page	15
Attachment: Sample Brochure	



## BUSINESS INFORMATION

Koff & Associates (“K&A”) is a full spectrum, public-sector human resources and recruiting services firm that was founded by Gail Koff in 1984, and has been assisting cities, counties, special districts, other public agencies, and non-profit organizations.

As of April 30, 2021, we merged with Arthur J. Gallagher and are now officially a Gallagher Division. Our headquarters are in Berkeley, CA, and we have satellite offices in Southern California, the Central Valley, the Sacramento Region, and the Western U.S. Region. GALLAGHER BENEFIT SERVICES, INC. is our legal name. It is a Delaware company, and the FEIN is 36-4291971.

## EXPERIENCE AND QUALIFICATIONS

With 37 years of HR experience, K&A Recruiting knows public sector employment inside and out. We are familiar with public sector organizational structures, agency missions, operational and budgetary requirements, and staffing expectations. Our team is ready to support you at any level you wish – providing sourcing expertise, full-cycle recruitment at the start of your search through the start date of your newest employee, and everything in between.

We build enduring relationships	K&A Recruiting provides personal attention to and creates long-term relationships with our clients. Because we care about and understand your organization’s people, culture, leadership, and unique needs, we identify highly qualified candidates to support your goals.
We value strength in diversity	We source top talent reflective of the communities you serve. With our focus on inclusion, networking and partnering with minority-based associations, utilizing bias-reducing tools, and drawing from our own employees’ certification training, we are leaders in public sector Diversity and Inclusion.
We leverage innovative search technology	K&A Recruiting uses advanced programs and unique sourcing methods to identify candidates which traditional recruiting strategies might have missed. We continuously gather and analyze important data points and are always looking ahead at how we can use information technology to better serve you.

Our long list of clients is indicative of our firm’s reputation as being a quality organization that can be relied on for producing comprehensive, sound, and cost-effective results. K&A Recruiting is “hands on” and responsive with the ability and expertise to identify the ideal candidate(s) for the City of Menlo Park.

K&A Recruiting uses its vast network to leverage recommendations and referrals of past clients in combination with modern sourcing techniques and technology to build the best candidate pools in the market. We are a team of true recruiters with over 60 years of combined experience. Our work speaks for itself, and our primary goal is to provide professional and technical consulting assistance with integrity, honesty, and a commitment to excellence.





## RECENT SUCCESSFUL RECRUITMENTS

Following is a partial list of recent executive recruitments conducted by Frank Rojas (some while at previous firm):

Agency	Title	Year Completed
City of Oxnard	Public Works Director, Asst. Public Works Director (2), Chief Financial Officer, Purchasing Manager, Controller, Communications & Marketing Manager, Assistant City Attorney, Civil/Traffic Engineers	Current/2020/2019/2018
City of San Diego	Director of Transportation	Current
County of San Mateo Transportation Authority	Deputy Director, Transportation Authority	Current
City of Glendale	City Manager	2021
County of Riverside	County Executive Officer	2021
City of Salinas	City Manager, Finance Director	2021
Kensington PP&CDD	General Manager	2021
City of Colton	Public Works & Utility Services Director	2021
City of San Bernardino	Finance Director, Director of Animal Services	2021/2020
City of Carson	Public Works Director, Community Services Director, City Manager	2021/2020/2019
City of Ontario	Economic Development Director	2021
City of Redlands	Director, Municipal Utilities & Engineering, Fire Chief	2021/2020
County of Orange Social Services Agency	Division Director (3), Deputy Director	2021/2020/2019
County of Tulare	Director of Human Resources & Development, Director of Information & Communications Technology	2021/2020
City of Millbrae	Director of Finance, Community Development Director	2020
City of Berkeley	Operations Manager (2), Public Works Director, Asst. City Attorney, Health Housing & Community Services Director	2021/2020
City of Avondale	Development & Engineering Services Director, Economic Development Director	2020/2019
City of Redlands	Fire Chief, Director of Municipal Utilities & Engineering	2020



City of Shafter	City Manager	2020
City of Ontario Municipal Utilities	Assistant General Manager	2020
City of Bell	Director of Community Development	2020
City of Los Angeles	Human Resource & Payroll Project Manager (ERP implementation)	2020
County of San Bernardino	Public Works Director, Human Resources Director, Assistant HR Director, Director of Land Use Services, Regional Parks Director	2020/2019/2018
Orange County LAFCO	Assistant Executive Officer	2020
LA Metro	Chief Ethics Officer	2020
Orange County Fire Authority	Purchasing Manager, Fleet Manager, Human Resource Director	2020/2017
City of Banning	Director of Administrative Services, Director of Parks and Recreation	2019
City of Santa Ana	City Manager, Parks & Recreation Director	2019
City of Bell Gardens	City Manager	2019
City of Anaheim	Deputy Planning Director, Engineering Manager, Buyer	2020/2018/2016
City of Garden Grove	Finance Director, City Manager	2019/2016
City of San Marino	City Manager	2018
County of San Luis Obispo	County Administrative Officer	2018
County of Imperial	County Executive Officer	2018
City of Avalon	City Manager	2018



## PROJECT TEAM, Cont.

### **Gary Palmer** **Executive Recruiter**

Prior to joining Koff & Associates, Gary worked in local government for over 20 years with his last position being City Administrator for the City of Roswell GA in metro Atlanta. After his first of two tours as an active-duty US Marine, Gary was sworn in as a police officer in the Washington DC area. Looking to further fulfill his passion for public service, Gary proceeded to work his way through the ranks in several cities serving as: Geographic Systems Analyst, City Planner, Grant Manager, Community Development Director (Metro Detroit), Assistant Town Manager, Town Manager (Knoxville TN) and most recently as City Administrator.

Gary understands leadership, what it looks like, and is dedicated to bringing it to our clients. Having led all City departments gives Gary inside knowledge of the dynamics within local government and ability to ask the right questions so he can find the best leader to address the client's needs. Moreover, Gary has the unique ability to tap into the many veteran networks to recruit proven leaders. Gary's recruiting experience includes: Police Chief, Fire Chief, Finance Director, Transportation Director, IT Director, Chief Information Officer, Community Development Director, and Parks and Recreation Director.

Gary has expertise in the following areas: city management, public safety administration, personnel management/coaching, budgeting and finance, land use, community and economic development, performance management and innovation. Additionally, Gary has extensive experience working closely and directly with elected officials on their individual and collective initiatives such as strategic planning, master planning, organizational/leadership development, and personnel management.

Gary has served on numerous inter-agency boards, panels, commissions, and councils throughout his career and has been heavily involved in the International City/County Manager's Association (ICMA). He is a graduate of Leadership ICMA 2010, the Senior Executive Institute at the University of Virginia, and the Senior Executives in State and Local Government at the Harvard Kennedy School. He is a credentialed city manager through the ICMA, Certified Planner through the AICP, and Certified Municipal Finance Officer through the State of Tennessee. Gary's formal education includes a Master of Public Administration.



## PROJECT TEAM

### **Frank Rojas** **Recruitment Manager**

Frank brings more than thirty (35) years of recruiting experience from the highly competitive direct placement and contract labor industries as well as the corporate environment. He has significant experience placing corporate leaders, executive, professional, and technical staff including individual contributors for government sector, non-profits, aerospace, architectural and engineering, information technology, petroleum and chemical, energy, power, civil/structural, transportation and private industry.

Frank began his career in Contract Labor and over the next 20+ years launched seven start-up offices in several states and locations providing direct placement and contract support to hundreds of clients in virtually all industries and levels of talent. He continued his career in the non-profit environment managing and building talent acquisition support during significant growth periods. Having been a speaker at several networking and career coaching venues, Frank believes in utilizing traditional recruiting methodology with social media.

In addition to recently completing recruitments for City of Salinas, County of Riverside, County of Tulare, City of Riverside, and City of San Diego, recent successful efforts include positions of County Executive Officer, Director of Human Resources & Development, City Manager, Finance Director, Chief Ethics Officer, and Director-level hires for Information Technology, Social Services, Public Works, Economic Development, Community Services, Animal Services, and Division/Site General Managers.

Frank has been named in the top 1% viewed profiles on LinkedIn and has established a strong client and customer base through trust, effective recruiting, relationship building, and teamwork.



## PROJECT APPROACH/METHODOLOGY

Our philosophy ensures thorough, thoughtful, and strategic sourcing, evaluation, selection, and vetting of candidates. This includes focused advertising including websites and publications specific to women and minority candidates, business media, outreach emails to perspective candidates and referral sources, contacting users' groups and associations, and of course picking up the phone and proactively calling passive professionals that may not otherwise be looking.

K&A Recruiting will provide weekly progress reports to the City Council and participate in conference calls and/or onsite meetings as requested.

We are responsible for ensuring compliance, adhering to and maintaining all legally mandated documentation throughout the process.

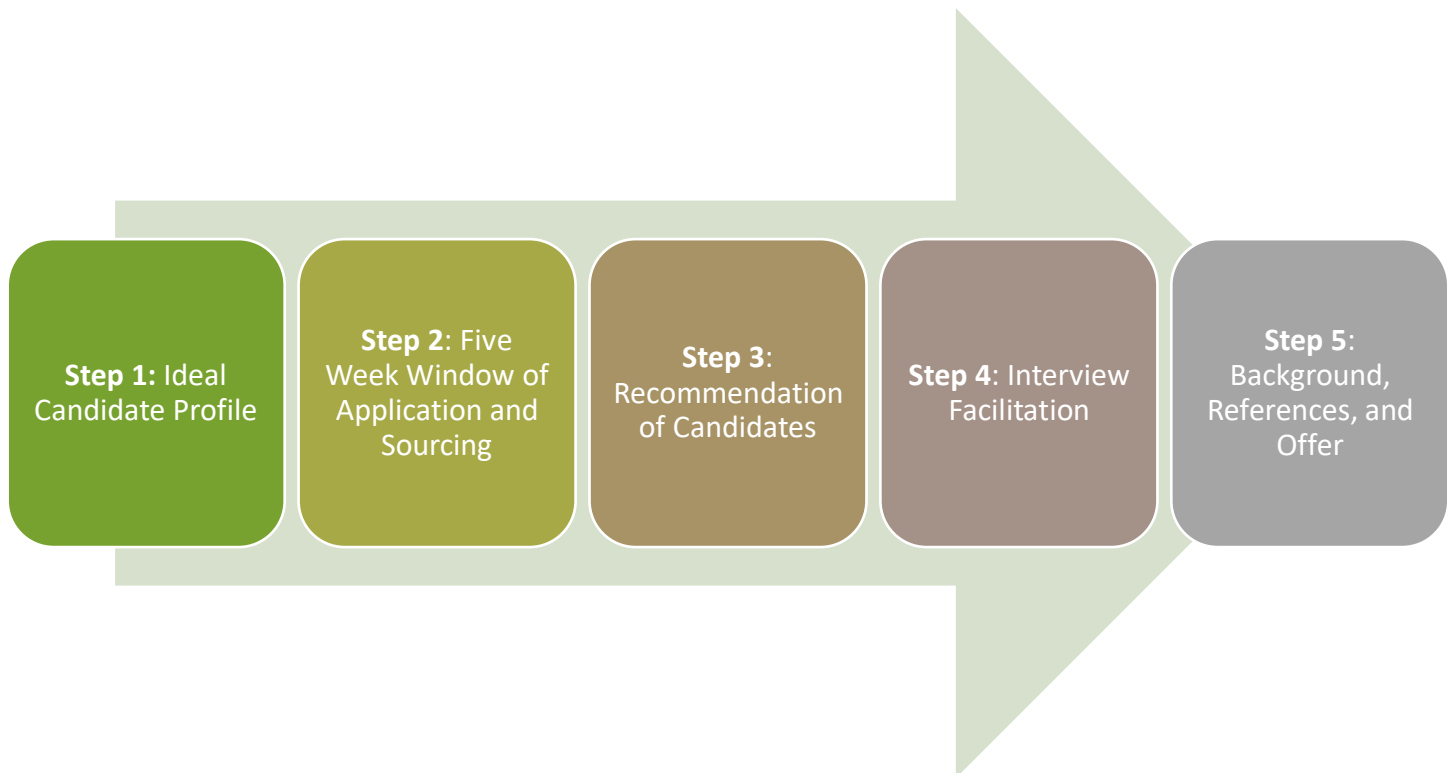



## Step 1 Ideal Candidate Profile

The development of a desired profile for the ideal job candidate for the position is crucial for a successful search process.

We will coordinate with the City Council in identifying and/or developing:

- The various organizational needs, vision, mission, goals, strengths, challenges, opportunities, culture of the City of Menlo Park and City Council;
- Position competency requirements, i.e., knowledge, skills, and abilities;
- Personal and professional attributes required of and priorities for the new incumbent;
- Type of working relationship senior leadership and the Hiring Authority desire with the new incumbent;
- Advertising strategies in conjunction with a national and/or regional outreach campaign;
- Compensation levels; and
- Schedule of deliverables from K&A Recruiting.

At the conclusion of the meeting(s) with the City Council, there will be a clear consensus of the key qualifications and characteristics of the position and the process, action plan, and timetable to be utilized for the recruitment process.

### Brochure Design & Posting

Following the development of the candidate profile, a professionally produced recruitment brochure will be prepared in coordination with the City Council prior to posting. The brochure will highlight the strengths of the City of Menlo Park, and surrounding community. Featuring its organizational structure and services such as hosting major employers such as Facebook and SRI international, its mission and goals to improve the quality of life of all residents, pertinent facts regarding the position, and necessary and desirable candidate qualifications.

## Step 2 Five Week Window of Application & Sourcing

K&A Recruiting can, at the request of the City Council, facilitate community surveys or community outreach forums to encourage feedback from residents. A report of resident comments will be provided to the City Council prior to the first round of interviews.

Our effort will include a variety of activities designed to build the best available candidate pool. Our techniques, methodologies, and previous successes will allow us to source from extensive pools of potential candidates and referral sources. This includes focused advertising, use of business/social media, email outreach, and of course, picking up the phone and directly talking with perspective applicants.

In coordination with the City Council, K&A Recruiting will:

- Identify prospects;
- Provide each potential candidate with access to the recruitment brochure;
- Capture interested candidates in our recruitment project database; and
- Provide representative data to the City Council including candidate documents, interview notes, and an outline of the recruitment process.



### Step 3 Recommendation of Candidates

K&A Recruiting will provide the City Council with a report of the leading candidates to further narrow the pool to the most highly qualified, and to establish best organizational fit of each potential finalist. This screening process is specifically designed to assess the personal and professional attributes the City Council has identified and will focus on each candidate's ability, technical competency, and fit with the City of Menlo Park's values, culture, and needs. Our assessment will consist of:

- Experience and qualifications;
- Cultural fit based on our understanding of important intangibles (such as, shaping new technologies and markets originating from Silicon Valley while improving the quality of life for the City's residents);
- Clarity of any issues identified in the submitted documents;
- Reasons for position interest,
- The level of commitment to the position and the organization; and
- Other issues, including salary requirements.

### Step 4 Interview Facilitation

We will advise and develop interviewing strategies and a menu of key questions that will help analyze candidates' qualifications and management/workstyle. We will facilitate all necessary communications with the Hiring Authority and candidates to ensure everyone is well prepared.

Interview questions will be designed to elicit information, not only about each candidate's technical skillset and experience, but also their leadership skills, adaptability, political astuteness, self-awareness, and other important aspects of the ideal candidate profile.

Questions, evaluation tools, and additional materials will be assembled using intuitive and user-friendly on-site interview binders. Should any additional evaluation criteria be required by the City Council, K&A will be happy to incorporate this into the process. The Project Manager will coordinate interviews, interview schedules, and finalize the process. We will provide oversight during the panel interview process and facilitate a focused discussion with the City Council at the beginning and conclusion of the interviews to identify the most qualified candidate(s) for final interviews.

### Step 5 Background, References, and Offer

K&A Recruiting will conduct thorough reference and background checks for the final candidate. We start with employment and professional references and provide a full service by personally calling each reference in order to have an in-depth discussion covering the candidate's strongest business characteristics, work style, interpersonal skills, and position-specific knowledge. All references will be documented and presented in a concise user-friendly manner.

Background checks are conducted in coordination with a third-party firm that will verify educational degrees and confirm clear driving records, criminal records, and financial history/credit. Safety for the organization and community is our priority, so rest assured that we contract with a background firm that meets or exceeds the reporting requirements of a governmental office.



K&A Recruiting can facilitate and lead the negotiations of the final terms and conditions of employment, such as the compensation package, benefits, and other perquisites (perks). We will notify all candidates not selected as finalists for the position.

### Project Schedule

The following is a typical schedule for conducting recruitment efforts. Search efforts for executive recruitments generally take twelve to fourteen (12-14) weeks to complete, allowing enough time for all steps of the process, and client schedules.

Weeks	2	4	6	8	10	12	14
Step 1							
Step 2							
Step 3							
Step 4							
Step 5							





## REFERENCES

We are proud of our past recruitment work with clients to successfully place candidates to meet their organization’s needs.

Recruitment & Agency	Contact
Oxnard, City of  Public Works Director, Asst. Public Works Director (2), Chief Financial Officer, Purchasing Manager, Controller, Communications & Marketing Manager, Assistant City Attorney, Civil/Traffic Engineers	Lisa Baker Assistant Director, Human Resources 805-385-7596 <a href="mailto:lisa.baker@oxnard.org">lisa.baker@oxnard.org</a> 4300 W. Third Street Oxnard, CA 93030
Redlands, City of  Director, Municipal Utilities & Engineering Fire Chief Manager, Municipal Utilities	Tommi Ng Asst. Director, Risk & Human Resources 909-708-7679 <a href="mailto:tng@cityofredlands.org">tng@cityofredlands.org</a> 35 Cajon Street Redlands, CA 92373
Carson, City of  Director of Public Works Director of Community Services City Manager	Faye Moseley Director of Human Resources and Risk Management  310-952-1735 <a href="mailto:fmoseley@carsonca.gov">fmoseley@carsonca.gov</a> 701 E. Carson Street Carson, CA 90745
Salinas, City of  City Manager Finance Director	Marina Horta-Gallegos Human Resources Director  (831) 758-7417 <a href="mailto:marinah@ci.salinass.ca.us">marinah@ci.salinass.ca.us</a> 200 Lincoln Avenue Salinas, CA 93901

Some completed by Frank Rojas during his time at previous employer.



## PRICING PROPOSAL

### Project

- City Manager

### Professional Fee and Expenses

- Professional Fee \$18,000, plus not to exceed \$7,000 for expenses.
  - Expenses include brochure development and design, advertising, printing and shipping, associated consultant travel, and background. The \$7,000 is a not to exceed amount, but may end up being less.
  - Expenses will be billed in correlation to the steps described.

*Note: Expenses do not include candidate travel.*

### Placement Guarantee

K&A Recruiting is committed to recommending only the most qualified candidates who not only meet all the necessary requirements and qualifications but are also a cultural fit for the unique needs of the City of Menlo Park. We proactively recruit for each search effort until a successful candidate is placed.

We therefore promise to present a slate of candidates to the City Council that includes only those individuals who have passed through our proactive screening processes and have been identified as potential ideal matches for the position requirements. Our priority is to be a partner to the City of Menlo Park, which means your satisfaction is our priority. Should the City Council disapprove of all final candidates and/or should none of the final candidates pass the final interview and reference check process, we will work to find a new slate of candidates at no added cost, with the possible exception of necessary advertising.

In addition, for executive and mid-management positions that we have filled, should the incumbent leave the position or be terminated from employment within 12 months of hire due to performance issues we promise to conduct a one-time additional executive search to identify a replacement and only charge related expenses as described in the Pricing Proposal.

Overall, K&A Recruiting’s retention rate during the first 12 months of hire is very strong and has been at over 95% over the last 37 years.



## Recruiting Process During Covid-19 Crisis

We will work to counterbalance market forces and build a pipeline of potential candidates through strong marketing and branding efforts, including videos, job postings, and a social media campaign. Our ongoing communication with candidates helps with reputation and keeps them engaged; so, when there is an opportunity that matches their background, we reduce the time-to-hire. As always, communication is key. Candidates who experience a warm, communicative recruitment experience are more likely to maintain their interest and are more likely to feel welcomed into the organization. The recruitment experience is the first touch point with your future new employees and a crucial factor in employee engagement and tenure.

We have embraced the virtual interview. The push into virtual technologies due to the pandemic was generally new for many public agencies. Our crystal ball tells us that virtual interviewing is not going away regardless of how the public sector world evolves going forward beyond the pandemic. In other words, virtual interviewing may have become a necessity during a temporary crisis, but it is not a temporary strategy that should fall to the wayside after the crisis is over. How we communicate in virtual interviews is essential and will continue to be going forward.

To conduct an effective virtual interview, simple steps can be taken to ensure a predictable and high-quality process. We will be clear on exactly how the interview process will go and what candidates should expect. We are savvy at navigating the technology and can help with technical challenges on the fly. Coaching panel members to continue to maintain a professional demeanor during virtual interviews, and eliminate smart phone or competing screen distractions, just as you would in person, can also help the process.

## K&A Recruiting Organizational Diversity Statement

This statement reaffirms our commitment to affirmative action efforts and providing equal employment opportunity to all employees and applicants for employment in accordance with equal opportunity and affirmative action laws.

We pledge our personal and official support of these policies which state that K&A Recruiting is committed to the implementation of the affirmative action policies, programs, and procedures included in this plan to ensure that employment practices are free from discrimination. Employment practices include but are not limited to, the following: hiring, promotion, demotion, transfer, recruitment or recruitment advertising, layoff, disciplinary action, termination, rates of pay or other forms of compensation, and selection for training, including apprenticeship. We will provide reasonable accommodation to applicants and employees with disabilities.



## OTHER: INSURANCE CONSIDERATIONS

We will submit and support the levels of coverage and endorse the City with our General Liability coverage upon award of a contract for the project.

- Workers' Compensation: Statutory Limits
- Commercial General Liability: \$2,000,000 per occurrence
- Professional Liability (Errors & Omissions): \$1,000,000 per occurrence
- Automobile Insurance: \$1,000,000 per occurrence

We will be pleased to sign the City of Menlo Park's professional services contract for recruitment services. We respectfully request that the City Council allow for a period of negotiation of certain terms in the professional services contract related to liability, indemnity, insurance, and other terms. We have found that we have always come to an agreement with all our clients in the past and appreciate the City Council's flexibility in reviewing certain terms in a collaborative fashion between our legal counsels.



## SIGNATURE PAGE

We thank you for your consideration of our proposal. We are committed to providing high quality service and investing in a long-term partnership.

This proposal is valid for ninety (90) days.

Respectfully submitted,

By: KOFF & ASSOCIATES

State of California

Frank Rojas

Date: July 19, 2021

---

Recruitment Manager

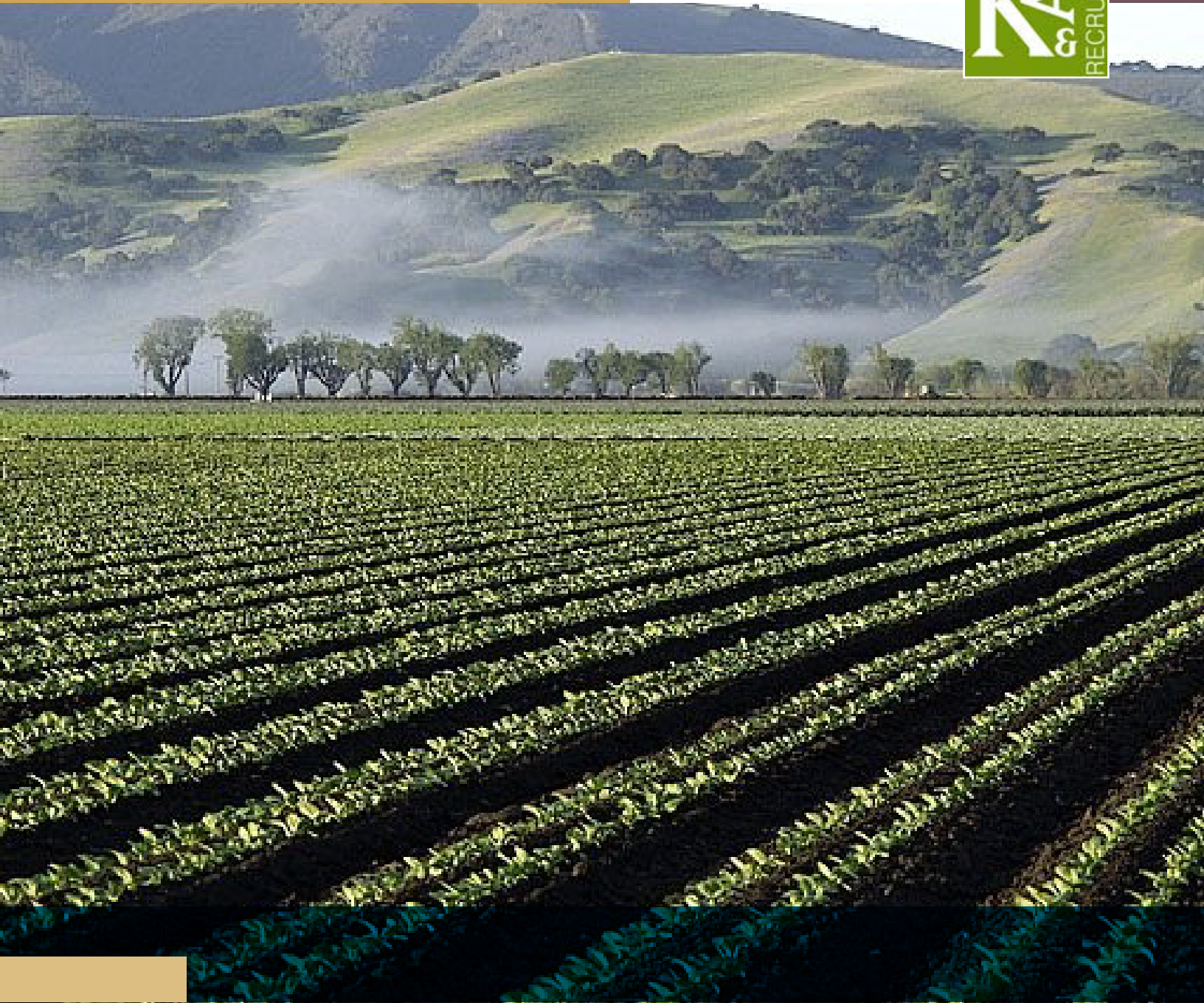

# Finance Director



## THE COMMUNITY

The City of Salinas is the 34th largest City in the state with a population of approximately 155,205. Salinas is located in beautiful Monterey County, and is the County seat. Just 40 minutes south of the heart of the nation's high-tech industry, Silicon Valley, the City has the largest population in California's Central Coast, is a multicultural and diverse community and a key asset in today's global economy. The region also boasts spectacular scenery, from breathtaking mountains and valleys, to the beauty of the sun, sand, sea, and soil. Salinas serves as the main business, governmental and industrial center of the region. The marine climate is ideal for the floral industry, grape vineyards, and vegetable growers. Salinas is known as the "Salad Bowl of the World" for its large, vibrant agriculture industry. The City is rich in diversity with an approximate 75% Hispanic population and a median age of 34, which allows for various cultural family activities and world class annual events such as the California Rodeo Salinas, El Grito Festival, Forbes Ag Tech Summit and world-renowned amenities right next door, including the Pebble Beach Golf Resort and the Monterey Bay Aquarium. Salinas is home to Hartnell, a robust community college, along with being just minutes from Cal State Monterey Bay. The City is also home to a wealth of cultural and historic assets, including the California Welcome Center/Regional Heritage Center and the National Steinbeck Center – the only museum in the country devoted to a single author - along with Steinbeck's family home. Salinas is the birthplace of John Steinbeck.

Although agriculture forms the economic base, more than 100 manufacturing, financial, and medical related firms call Salinas home. Salinas has a global reputation as an agriculture and innovation hub, it is a source for agricultural research and resources and is developing the latest technology and advancements. Some of the largest employers in the city include the County of Monterey, Taylor Farms, D'Arrigo Bros, and Salinas Valley Memorial Hospital.

Visitors can also explore the nearby Monterey Peninsula: the historic missions of San Juan Bautista, Soledad, Carmel and San Antonio de Padua, the world class wineries of South Monterey County and the beauty of nearby beaches and Pinnacles National Monument.

## CITY GOVERNMENT

The City of Salinas was incorporated in 1874 and became a Charter City in 1903. The City operates under a Council-City Manager form of government. The seven-member City Council includes six members elected by district for four-year staggered terms on a nonpartisan basis, plus the Mayor who is elected at-large and serves a term of two years. The City employs 530 full-time staff with 200 additional temporary employees. The total Operating and Capital budget is \$189 million. The City Manager leads and directs eight departments which include Administration, Community Development, Finance, Fire, Human Resources, Library and Community Services, Public Works, and the Police Department.

## THE DEPARTMENT

The Finance Department provides coordination and direction of all fiscal operations of the City. This includes, but is not limited to:

- ❖ Directing, monitoring, and controlling all assets and financial operations of the City.
- ❖ Providing a framework for financial planning and analysis to support the operation and management of all City Departments.
- ❖ Financial administration of the Successor Agency to the former Salinas Redevelopment Agency, Assessment Districts, Enterprise Operations, Internal Services and Trust Funds, and the City's General Fund.
- ❖ Managing a staff of approximately 25 I.T. and Finance professionals.

Departmental responsibilities include long-range financial planning, budget management, accounts receivable and payable, payroll, retirement administration, general accounting and reporting, debt administration, purchasing, revenue and licensing, information technology and assessment district administration.



**General Fund & Measure E & G FY 2020-21  
Expenditure Budget \$116,765,183**

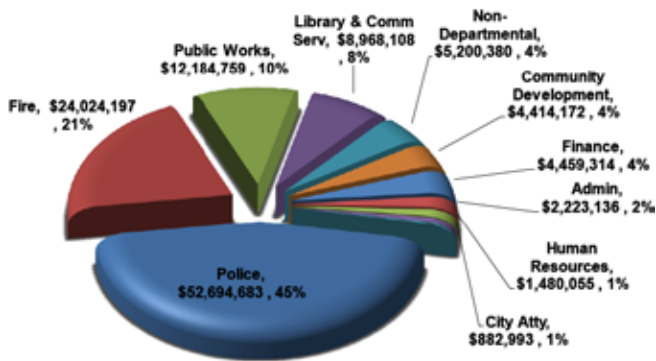

## THE POSITION

The Finance Director plans, organizes, directs, and reviews the activities of the Finance Department including accounting, treasury management, revenue and licensing, information systems, purchasing, and central services; provides coordination and direction of all fiscal operations of the City including directing, monitoring, and controlling the assets and financial operations of the City; provides a framework for financial planning and analysis to support the operation and management of all City departments; oversees the resources and activities of the City-wide Information Technology (IT) function; and offers professional and technical staff assistance. This position assists in the preparation, implementation, and control of the City's annual operating and capital improvement budgets. The incumbent will coordinate, review, evaluate, and recommend improvements to the City's administrative and financial internal control systems and procedures, ensure audit compliance, administer deferred compensation programs and retirement plans, as well as the bonded indebtedness of the City. The Finance Director serves as City Treasurer and acts as fiscal officer for non-City agencies, prepares written and oral reports to staff, commissions, and City Council and performs other related duties as needed.

## CURRENT PRIORITIES AND OPPORTUNITIES

- ❖ Promote a culture of learning and communication that ensures the community is well informed while providing a high level of transparency, ethics, and confidence in local government.
- ❖ Provide financial guidance relevant to operational expenditures and closing budget gaps.
- ❖ Emphasize government transparency, trust, and accountability.
- ❖ Continue to enhance team building and interdepartmental collaboration.

- ❖ Develop an understanding of the City's diversity and ways to meet the needs of each unique population, and find commonalities to unify and build a stronger sense of community.
- ❖ Build a foundation of community involvement through access of information including policy direction and providing a voice and open communication to and from the general public.
- ❖ Hire a new Assistant Finance Director.

### The Salinas Plan:

The Salinas Plan is a Ten-Year Plan designed to provide the City with a path forward on maintaining a long-term balanced, sustainable budget while preserving City services and addressing the affordable housing crisis.

## THE IDEAL CANDIDATE

The ideal candidate will be an honest, collaborative, and confident leader with excellent supervisory skills; a strong communicator able to write reports with clarity and verbally articulate fiscal concepts to all levels of audiences. The Finance Director will manage a solid team and should have a willingness to delegate, and be a mentor, willing and able to develop staff. It is important for this individual to keep abreast of the American Rescue Act and be able to oversee multiple grants. The incumbent will be a responsible steward for the community, City staff, and leadership, and align decisions in support of the Salinas Plan. The ideal candidate will have a proven track record in implementing efficiencies, allowing the Department to assist the organization in achieving its financial goals.

The successful candidate will have demonstrated expertise and a solid track record in municipal finance and budget management, agency administration, and the ability to maintain collaborative relationships with City Council, staff, and the community. Excellent interpersonal abilities are necessary to build and maintain solid relationships with elected officials, regional business partners, union representatives, staff, and the community through open and respectful dialogue. It is important to engage and embrace the cultural diversity of the City.

### Key Attributes and Characteristics

- ❖ A strong leader who shares the vision of the council and community, and can advocate, articulate, and implement that vision. A manager who is able to blend innovation and creativity, someone who can think outside the box.
- ❖ A professional who can lead the organization with a commitment to uphold the values of Salinas, including valuing positive employee working relations and respecting the richness of cultures and diversity.



- ❖ A friendly approachable leader who can ensure quality customer service.
- ❖ Diplomatic, being known as a people person with an engaging style that is comfortable interacting with a wide spectrum of individuals and one who welcomes dialogue and discussion.
- ❖ A decisive, seasoned leader with the highest integrity, character, and ethics.
- ❖ Honest, with the ability to maintain and build trust and actively listen.
- ❖ Technologically astute, who recognizes the value of harnessing and integrating the benefits of cutting-edge technology for city government and for residents.
- ❖ A proven understanding of budget/structural deficits and the willingness and the ability to bring teams together to find solutions to challenging issues.
- ❖ An outstanding fiscal manager, able to develop and implement plans to expand the tax base, obtain grants, and manage costs.

## MINIMUM QUALIFICATIONS

- ❖ Bachelor's Degree in Public Administration, Business, Accounting, Finance, or a related field.
- ❖ Master's Degree (MA/MS) is highly desirable.
- ❖ Eight (8) years of senior-level municipal management experience in a public service setting with extensive experience working with a City Council or a Board of Supervisors.
- ❖ Four (4) or more years of senior management experience in local government of a comparable size to the City of Salinas is helpful.

## COMPENSATION AND BENEFITS

**The salary range for the Finance Director is \$144,048 - \$175,080 DOQ**

The City offers an attractive benefits package which includes:

- ❖ CalPERS Retirement Plan –The City participates in the California Public Employees' Retirement System (CalPERS) under a 2% @ 55 formula for Classic members. New members, as defined by PEPR, are under a 2% @ 62 formula.
- ❖ 457/401(a) Compensation – City-paid contribution based on months of service with the City.
- ❖ Health Insurance – The City currently pays 95% of the premium for the level of coverage the employee has selected, up to 95% of the PERS Choice Plan premium. The City pays the full amount of premiums for dental and vision plans.
- ❖ Holidays – 12 per year.

- ❖ Annual Leave – May be used for vacation and/or sick leave. Leave is accrued at a rate of 37 days per year for the first five years; 42 days per year for years six through ten, with additional longevity increase in annual leave after ten years of employment.
- ❖ Life Insurance – Term life insurance in the amount of \$150,000.
- ❖ Bilingual Pay - \$75 per pay period if Spanish is used in the course of his/her job duties (subject to passing a City-administered bilingual exam and administrative approval).
- ❖ Auto – City assigned vehicle or \$750 per month auto allowance.

## APPLICATION PROCESS AND RECRUITMENT SCHEDULE

**The final filing date is Friday, May 28, 2021.**

To be considered, please submit a resume, cover letter, and five work related references (who will not be contacted in the early stages of the recruitment) to: [koffassociates.com/finance-director-2/](https://koffassociates.com/finance-director-2/).

Resumes should reflect years and months of positions held, as well as size and budgets of past organization(s).



For additional information, please contact:

Frank Rojas  
 Recruitment Manager  
 Phone (510) 495-0448  
[frojas@koffassociates.com](mailto:frojas@koffassociates.com)  
 Website: <https://koffassociates.com/>

Resumes will be screened based on the criteria outlined in this brochure. Candidates with the most relevant qualifications will be given preliminary interviews by the consultant. Koff & Associates will report the results to the City. The City will then select candidates to participate in City interviews on **June 17**. Extensive reference and background checks will be completed on the selected candidate.



Proposal to Provide  
Recruitment Services for the position of

# CITY MANAGER

for the City of

# Menlo Park

CALIFORNIA



Prepared by

## **Ralph Andersen & Associates**

Project Director: Fred Wilson

Project Co-Director: Heather Renschler

Submitted: August 6, 2021

[www.ralphandersen.com](http://www.ralphandersen.com)



5800 Stanford Ranch Road  
Suite 410  
Rocklin, California 95765  
916.630.4900

August 6, 2021

Mayor Drew Combs  
and Members of the City Council  
City of Menlo Park  
701 Laurel Street  
Menlo Park, California 94025

Dear Mayor Combs and Members of the City Council:

Ralph Andersen & Associates is pleased to submit this proposal to conduct a search for the position of City Manager for the City of Menlo Park.

If selected to conduct this search, the City will have the Search Team of Mr. Fred Wilson and myself as Project Co-Directors for this engagement. As a former City Manager with over 35 years of experience including 20 years serving as a City Manager in different communities, Mr. Wilson is highly qualified to lead this search. Additionally, as President and CEO of the firm I will provide additional assistance on candidate identification and outreach. We believe this collaborative approach will serve the City of Menlo Park well in a robust outreach to candidates.

We utilize a team approach to executive recruitments, combining the efforts of our 14-member search team to produce the best results for our clients. The executive recruitment techniques used by Ralph Andersen & Associates have been developed and used successfully with hundreds of clients for more than 49 years. With the reputation of Ralph Andersen & Associates you will have the opportunity to consider candidates located throughout California as well as from across the nation.

Importantly, since 2016, the firm has successfully conducted 66 City Manager recruitments. This recap does not include any assistant or deputy city managers which are in addition to this number. Additionally, we currently have a total of eight city manager searches under contract at the present time including six active recruitments for the California cities of Barstow, Citrus Heights, Lincoln, Nevada City, Sierra Madre, and Upland and one out-of-state (City of Lewisville, Texas). Also, a newly awarded search in Marin County will commence soon (Town of Fairfax – Town Manager). A full listing of completed city manager engagements has been included in this Proposal beginning on Page 5.

Ralph Andersen & Associates has the available resources to focus on and conduct the City Manager search for the City of Menlo Park based on the timing of existing searches and the upcoming completion dates. Additionally, ensuring that the City has a diverse selection of qualified candidates to select from could not be more important than now. Ralph Andersen & Associates has long recognized the value added by diversity and has tracked every woman and minority placement since our firm's incorporation in 1972. A copy of our Women and Minority Placement Listing is included with this proposal as a separate attachment.

We are proud of how we market and represent our clients; all of the design and graphics of our marketing material is done in-house so we can control the quality and production timing. Sample recruitment brochures for City Manager searches from the cities of Los Altos and Sierra Madre are attached for your further reference and review. Mr. Wilson was the Project Director on both of these successfully completed engagements.

Should you need any clarification, please feel free to contact our firm at (916) 630-4900. Thank you very much for your consideration of this proposal.

Respectfully Submitted,

Heather Renschler  
President / CEO



## Overview of the Firm

### Executive Summary

Attracting top talent has never been more complex and Ralph Andersen & Associates is highly qualified to assist the City of Menlo Park with recruiting its new City Manager. We have conducted more successful executive recruitments than any other firm in California since 1972. From helping the City Council to create a competency-based interviewing framework for the new City Manager to assessing candidates and attracting top human capital, our search professionals offer an unparalleled depth of experience, national reach, and knowledge.

The City Council has requested our proposal to assist in the identification and recruitment of a highly qualified group of candidates for the new City Manager. In particular, the City of Menlo Park is seeking a firm with a strong presence in California and the professional experience to clearly assess the City's needs and formulate a strategy to **deliver results**.

At Ralph Andersen & Associates, we believe that gaining a complete understanding of our client's specific objectives and priorities is essential prior to launching any search assignment. This process includes the identification and incorporation of a variety of important details such as the candidate's desired skills and experience as well as the critical "soft skills" related to temperament, personality, management philosophy, and other factors that will ultimately determine the candidate's "fit" with the organization.

We begin each search by working closely with the City's leadership, stakeholders, staff, and, if desired, the community to ensure a complete picture of the desired candidate pool is developed. Our team-oriented approach, matched with this 360-degree perspective, means we ensure that a complete understanding of the organization's mission and culture translates into those specific traits and characteristics necessary to ensure the selected candidate is successful in the position.

We understand that the City Council expects aggressive, personalized outreach to identify a diverse and highly qualified applicant pool and a selection process that includes comprehensive candidate reports based on thorough reference and background checks. We will begin with the desired characteristics and build a recruitment strategy that is tailored to meet the City of Menlo Park's specific needs. The resulting outreach and advertising campaign will incorporate the extensive use of personal outreach to recruit a highly qualified group of candidates.

Ralph Andersen & Associates serves a nationwide clientele through its Corporate Office in the Sacramento area. The Corporate Office is located at 5800 Stanford Ranch Road, Suite 410, Rocklin, California 95765; phone number (916) 630-4900.

Our national staff of professionals and support staff include acknowledged leaders in their respective fields. Supplementing their extensive consulting backgrounds, all senior staff have personal, hands-on executive experience in the operation of public agencies and private businesses.

The principals of the firm are Heather Renschler, President/CEO, and Robert Burg, Executive Vice President. Both Ms. Renschler and Mr. Burg are legally able to bind the firm.

## Range of Services Offered

Ralph Andersen & Associates specializes in the following primary service areas: executive search, management consulting, and human resources consulting.

- **Executive Search** – At Ralph Andersen & Associates, there's always an entire team behind every recruitment assignment that we undertake. Our multi-disciplinary approach takes the best ideas in executive recruiting and creates innovative ways to get the right candidates for clients. When you retain Ralph Andersen & Associates, you actually get an entire team's worth of support and expertise working together to achieve your organization's objectives. The firm has conducted executive searches for large and small organizations throughout the nation. In addition to conducting searches for city manager and other chief executive officer positions, Ralph Andersen & Associates has successfully completed searches in every area of municipal service. Ralph Andersen & Associates believes the most important element of a successful executive search is to listen carefully to what our clients are looking for in terms of candidate experience and qualifications. Using these client-focused guidelines, candidate identification is undertaken through marketing and personal outreach.
- **Management Consulting** – Ralph Andersen & Associates helps organizations improve their performance potential with a range of management consulting services. The types of services provided by the firm include management and performance audits, organizational analyses, productivity improvement analyses, agency and service consolidation assessment, specialized financial management including debt restructuring and organizational problem solving. In addition to providing these services to entire organizations, the firm often conducts management consulting engagements that are focused in a specific service area such as public safety, city management, finance, public works, community development and other major service areas. Ralph Andersen & Associates treats every management consulting engagement as unique. This approach means we will assemble a consulting team comprised of consultants with the specific talents and experiences needed to successfully achieve the client's objectives. Our team of experienced consultants perform complex analyses and recommend solutions that are practical and most importantly, are capable of being implemented by our clients.
- **Human Resources Consulting** – The firm provides a full range of contemporary human resources consulting including classification studies, compensation studies, benefits analysis, pay plan development, executive pay, and pay for performance. Key staff have proven success in working with labor groups and elected officials in identifying solutions and solving challenging problems. Services also include expert witness services for mediation and arbitration hearings. Our approach to consulting services is characterized by proven methods, extensive data collection, accurate analysis, and effective communication and messaging.

## Project Staffing

The reputation of the search firm and personal commitment of the recruiters define the difference between the success and failure of any given recruitment. Ralph Andersen & Associates' search professionals are acknowledged leaders in the field and possess a broad range of skills and experience in the areas of local government management, executive search, and related disciplines. Only senior members of Ralph Andersen & Associates are assigned to lead search assignments, ensuring that their broad experience and knowledge of the industry is brought to bear on our clients' behalf.

The City of Menlo Park will have Mr. Fred Wilson, Senior Consultant, and Ms. Heather Renschler, President/CEO of Ralph Andersen & Associates, as the Search Team on this engagement. Mr. Wilson and Ms. Renschler will have all the resources and full support of our firm fully dedicated to ensuring the highest quality outcome during this important recruitment process.

**Mr. Wilson is readily available to start the project while also available to attend on site client meetings, as necessary.**

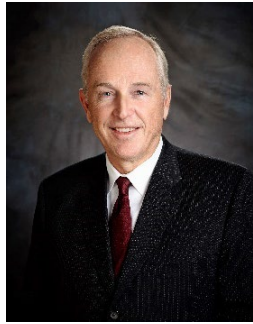

### **Fred Wilson, Project Director (Lead Consultant)**

Mr. Wilson, Senior Consultant with Ralph Andersen & Associates, brings more than 35 years of experience as a local government executive, including 21 years serving as City Manager in two California cities. Working in full-service cities, he brings a strong background in identifying and recruiting top quality executive staff. His skills in identifying, recruiting, and retaining high quality employees and talent management, coupled with succession planning, have contributed significantly to the successes of those organizations. This experience gives Mr. Wilson a unique perspective to identifying high quality candidates that “fit” the organization.

Mr. Wilson has served as Project Director for five City Manager recruitments and two Deputy City Manager recruitments in the past 12 months.

Since joining Ralph Andersen & Associates, Mr. Wilson has completed many successful recruitments and brings a vast network of contacts throughout the region. He has successfully completed searches for executives and professionals for local government organizations including City Managers, Community Development Directors, Public Works Directors, Finance Directors, and other General Managers.

Mr. Wilson’s clients have found his knowledge of city management, experience working with City Council members, and expertise in recruitment and selection an asset. Most recently, Mr. Wilson was the Project Director on the City of Los Altos City Manager search which successfully placed Gabriel Engeland as their City Manager.

As a long-tenured local government executive, Mr. Wilson has extensive experience in all aspects of governance including organizational development, succession planning, municipal finance, community development, and general management. His experience includes serving in multiple leadership roles in various organizations including the League of California Cities and has been active on various advisory boards throughout his career.

Mr. Wilson holds a Bachelor of Science degree in Urban Planning from Cal Poly Pomona, and a Master’s degree in Public Administration from California State University, Northridge.

Mr. Wilson may be reached at (916) 630-4900 or directly on his cell at (714) 421-3258 or via email at [fred@ralphandersen.com](mailto:fred@ralphandersen.com).



### **Ms. Heather Renschler, Project Co-Director**

Ms. Renschler has been with Ralph Andersen & Associates for more than 36 years and is the firm’s President/CEO. Ms. Renschler has overseen the recruitment practice of Ralph Andersen & Associates for the last 24 years and, as a result, is often involved with recruitments on a national scale and those of a highly sensitive and critical nature. She is experienced at working with City Councils, governing boards, District councils, staff members, and selection committees in the recruitment and selection process.

Ms. Renschler has extensive experience working with elected officials and clients to finding the right candidate based on the opportunities and challenges facing the organization and the community. Her network of potential candidates is broad-based and extends throughout California and nationally.

Prior to joining Ralph Andersen & Associates in 1985, Ms. Renschler had private sector experience in the areas of construction management, health care, and public accounting.

Ms. Renschler attended the University of Toledo and majored in Accounting and Journalism and obtained a Bachelor's degree in Public Administration from the University of San Francisco.

Ms. Renschler may be reached at (916) 630-4900 or directly on her cell at (916) 804-2885 or via email at [heather@ralphandersen.com](mailto:heather@ralphandersen.com).

## Paraprofessional and Support Staff

Paraprofessional, graphics, and support staff will provide administrative support to the consultant team on recruitment assignments. These may include Ms. Diana Hausmann, Ms. Christen Sanchez, Ms. Hannah Jones, Ms. Karen AllGood, Ms. Tina Keller, and Ms. Teresa Heple.



# Qualifications and Experience

## Why Choose Ralph Andersen & Associates?

Ralph Andersen & Associates, a California Corporation, has been providing executive search and management consulting services since 1972. As such, the executive recruitment techniques used by Ralph Andersen & Associates have been developed and used successfully with hundreds of clients for more than 49 years. The Corporate Office of Ralph Andersen & Associates is located in the Sacramento Area (Rocklin).

**With Ralph Andersen & Associates, there is an entire team behind every recruitment.** Our firm takes a multi-disciplined, team approach to executive search. Successful outreach relies heavily on person-to-person contact to identify outstanding potential candidates and, in the evaluation phase, to gain a complete understanding of the background, experience, and management style of the top candidates. By drawing on the combined expertise of our associates and our network of professional contacts, we address outreach from a wide variety of perspectives and find unique ways to identify and recruit the best and brightest.

## Relevant Search Experience

Ralph Andersen & Associates conducts a wide array of searches in the public sector specializing in the top executive in local government – the City Manager. Our experience spans populations of all sizes, from the largest in the country to small and mid-size municipalities.

Ralph Andersen & Associates' significant experience in city management searches is supported by a successful track record of highly regarded managers.

**Below is a listing of city manager related recruitments** conducted or in-progress by Ralph Andersen & Associates (2016 to Present):

- Allen, TX – City Manager (2019)
- Apple Valley, CA – Town Manager (2018)
- Auburn, CA – City Manager (2017)
- Austin, TX
  - Assistant City Manager for Economic Opportunity & Affordability (2018)
  - Assistant City Manager for Health & Environment / Culture & Lifelong Learning (2018 & 2021)
  - Assistant City Manager for Mobility (2019)
  - Assistant City Manager for Safety (2019)
  - Deputy City Manager (2019)
- Barstow, CA – City Administrator (Current Search)
- Belvedere, CA – City Manager (2017)
- Beverly Hills, CA – Deputy City Manager (2019)
- Bishop, CA – City Administrator (2018 & 2020)



- Brownsville, TX – City Manager (2018)
- Buellton, CA – City Manager (2019)
- Burleson, TX – Deputy City Manager (Current Search)
- Calabasas, CA – City Manager (2018 & 2021)
- Carmel-by-the-Sea, CA
  - Assistant City Administrator (2017)
  - City Administrator (Backgrounds) (2016)
- Charlotte, NC
  - Assistant City Manager (2019)
  - City Manager (2016)
- Citrus Heights, CA – City Manager (Current Search)
- Colma, CA – City Manager (2017)
- Corona, CA – City Manager (2019)
- Coronado, CA – City Manager (2021)
- Costa Mesa, CA – City Manager (2019)
- Cupertino, CA – City Manager (2019)
- Delray Beach, FL – City Manager (2019)
- Denton, TX – Assistant City Manager (2019)
- Encinitas, CA – City Manager (2020)
- Fountain Valley, CA – City Manager (2017)
- Goleta, CA – Deputy City Manager (2017 & 2019)
- Green Valley Recreation, Inc. – Chief Executive Officer (2020)
- Indio, CA – City Manager (2021)
- Irvine, CA
  - Assistant City Manager (2016)
  - City Manager (2018)
- La Palma, CA – City Manager (2020)
- La Quinta, CA – City Manager (2019)
- Laguna Niguel, CA – City Manager (2017)
- Lake Forest, CA – City Manager (2017)
- Lawrence, KS – City Manager (2016 & 2019)
- Lewisville, TX – City Manager (Current Search)
- Loomis, CA – Town Manager (2017)

- Los Altos, CA – City Manager (2021) – **Brochure Attached**
- Los Banos, CA – City Manager (2016)
- McKinney, TX
  - Assistant City Manager (2017)
  - City Manager (2016)
- Miami Beach, FL – City Manager (2021)
- Mill Valley, CA – City Manager (2020)
- Modesto, CA
  - Deputy City Manager for Operations (2018)
  - Deputy City Manager for Support (2018)
- Monterey, CA – City Manager (2018)
- Moorpark, CA – City Manager (2018)
- Morro Bay, CA – City Manager (2017)
- Nevada City, CA – City Manager (Current Search)
- Norfolk, VA – City Manager (2017)
- Ocean Reef Community Association, FL – President (2019)
- Oakland, CA – City Administrator (2020)
- Pacific Grove, CA – City Manager (2016)
- Palm Desert, CA
  - Assistant City Manager (2019)
  - City Manager (2016 & 2021)
- Paso Robles, CA – Assistant City Manager (2019)
- Pomona, CA – City Manager (2019)
- Powell, OH – City Manager (2020)
- Redlands, CA – City Manager (2019)
- Reno, NV
  - Assistant City Manager (Current Search)
  - City Manager (2017)
- Rialto, CA – City Administrator (2019)
- Sacramento, CA
  - Assistant City Manager (Backgrounds) (2016)
  - Assistant City Manager – Public Safety (2018)
  - Assistant City Manager – Municipal Services (2019)
  - City Manager (2017)

- San Bruno, CA – City Manager (2018)
- Santa Monica, CA – City Manager (2021)
- Sierra Madre, CA – City Manager (Current Search) – **Brochure Attached**
- South Jordan, UT – Assistant City Manager (2016)
- South Padre Island, TX – City Manager (2017 & 2019)
- Stockton, CA – Deputy City Manager II (Two Placements) (2020)
- Sugar Land, TX – City Manager (2019)
- Suisun City, CA – City Manager (2019)
- Sun City West, AZ – General Manager (2019)
- The Woodlands Township, TX – President and General Manager (2020)
- Upland, CA – City Manager (Current Search)
- Upper Arlington, OH – City Manager (2019)
- Vancouver, WA
  - Deputy City Manager – Community and Economic Development (2021)
  - Deputy City Manager for Enterprise Services (2021)
- Waxhaw, NC – Town Manager (2017)
- Westlake Village, CA – City Manager (2019)

# References

At Ralph Andersen & Associates, we feel strongly that our past client relationships will attest to the professionalism of our services. We would be pleased to provide references upon the City's request.

## References for Mr. Fred Wilson:

- **City of Los Altos**  
Neysa Fligor, Mayor  
(650) 485-9565  
Recruitment: City Manager
- **City of La Palma**  
Nitesh Patel, Mayor  
(714) 690-3334  
Recruitment: City Manager
- **City of Pomona**  
Tim Sandoval, Mayor  
(909) 620-2053  
Recruitment: City Manager

## References for Ms. Heather Renschler:

- **City of Mill Valley**  
John McCauley, Mayor  
(415) 388-4033 (City Hall)  
Recruitment: City Manager
- **City of Calabasas**  
James Bozajian, Mayor  
(818) 224-1600 (City Hall)  
Recruitment: City Manager

# Recruitment Strategy

## Summary of Our Search Process

The successful search process relies heavily on person-to-person contact to identify outstanding potential candidates and, in the evaluation phase, to gain a complete understanding of the background, experience, and management style of the top candidates. The executive recruitment techniques used by Ralph Andersen & Associates have been developed and used successfully with hundreds of clients for more than 49 years.

We feel that the key elements of the search process, which can be tailored to fit the specific needs of the City of Menlo Park, should include:

- Developing a comprehensive position profile based upon information obtained in meetings with the City Council and key staff members.
- Extensive personal outreach, via telephone and through internet technology, to qualified candidates throughout California and the Western Region. Outreach to qualified candidates on a national scale will also be included should this be the desire of the City Council.
- A marketing strategy that uses selected advertising to supplement the extensive candidate identification process, uses the Internet and social media, and also uses our already established professional contacts throughout the region.
- A screening and assessment process that narrows the field of candidates to those that most closely match the needs of the City and is based on extensive reference checks and telephone interviews with the top candidates.
- Delivering a product in the form of a search report that recommends the top group of candidates and provides the decision-makers with detailed information about their backgrounds and experience.
- Assistance during the interview and selection process and in the negotiation of a compensation package.

## Search Work Plan

This section describes the usual steps in the search for a new City Manager for the City of Menlo Park. This recruitment will be under the direction of Mr. Fred Wilson and Ms. Heather Renschler, Project Co-Directors.

**Given the uncertainty regarding in-person meetings due to the COVID-19 pandemic, kick-off and follow-up meetings may be conducted via videoconference if travel or in-person gatherings are not advised. We are hopeful that the candidate interviews may be done in person at a future date. Currently, we are handling the majority of finalist interviews via video with no issues.**

### Task 1 – Review Project Management Approach

The Search Team will begin work on this project within 10 days (or sooner) after the City provides a contract or, alternatively, an official notice to proceed. The first task will include established individual and/or group video meetings with the City Council and others (done via the Zoom Technologies application), as appropriate, to finalize the recruiting and selection process. This will include

discussion of the project management for this search, review of the work plan, confirmation of timing, and communication methods. Working collaboratively with the City Council and key City staff, this task will result in a more definitive timetable.

As part of our overall approach to this project, the Search Team will deliver regular status reports at each stage of the search. In addition, the Search Team will be highly accessible and responsive to client requests and inquiries.

## Task 2 – Develop Position Profile

The position profile for the City Manager is the guide for the entire search process. **Refer to the attached samples submitted with this proposal.** The development of the profile includes the collection of technical information and recruitment criteria.

### Technical Information

The Search Team will conduct video meetings with the City Council, the Human Resources Manager, key staff members, and others as directed by the City to gain an understanding of the experience and professional background requirements desired in the City Manager. These meetings, all done via video conferencing, will also help the Search Consultant gain an understanding of the work environment and the issues facing the City of Menlo Park.

### Recruitment Criteria

The recruitment criteria are those personal and professional characteristics and experiences desired in the City Manager. The criteria should reflect the goals and priorities of the City of Menlo Park.

Subsequent to the development and adoption of the candidate profile, the technical information and recruitment criteria will be documented in an information brochure prepared by Ralph Andersen & Associates. The brochure will be reviewed by the City in draft format, revised as appropriate, and published for use throughout the search.

**Optional Services** – The City Council may desire obtaining input from the Community on the qualities they would like to see in the new City Manager. To facilitate Community input, the Search Team can conduct an on-line survey. Additionally, our process can allow for email comments to Ralph Andersen & Associates relative to the desired qualities in the next City Manager. See Cost Section for more details on pricing.

## Task 3 – Outreach and Recruiting

This task is among the most important of the entire search. It is the focus of the activities of the Search Consultant and includes specific outreach and recruiting activities briefly described below.

### Outreach

An accelerated outreach and advertising campaign will be developed. It will include the placement of ads in publications such as *Western City Magazine*, *International City/County Management Association (ICMA)*, and other professional publications. Specific Internet sites related to government will be used as a method of extending the specific outreach in a short period of time.

Additionally, the advertisement and the full text of the position profile (the recruitment brochure) will be placed on Ralph Andersen & Associates' website, which is accessed by a large number of qualified candidates. This method of outreach to potential applicants provides a confidential source that is monitored by many key level executives on an on-going basis.

## Candidate Identification

Ralph Andersen & Associates will use their extensive contacts to focus the recruiting effort. In making these contacts, the Search Consultant will target those individuals who meet the criteria set by the City. Each of the candidates identified through the recruiting efforts will be sent an information brochure. Candidates will also be contacted directly to discuss the position and to solicit their interest in being considered.

Both the outreach and recruiting activities will result in applications and resumes from interested candidates. As they are received, resumes will be acknowledged and candidates will be advised of the general timing of the search process. The following tasks involve the actual selection process, once all resumes have been received.

## Task 4 – Candidate Evaluation

This task will be conducted following the application closing date. It includes the following specific activities:

### Screening

All of the applications will be carefully reviewed. Those that meet the recruitment criteria and minimum qualifications will be identified and subject to a more detailed evaluation. This evaluation will include consideration of such factors as professional experience, and size and complexity of the candidate's current organization as compared to the candidate profile.

### Preliminary Research and Internet Review

The research staff of Ralph Andersen & Associates, under the direction of the Search Team, will conduct preliminary research and internet review for those candidates identified as the most qualified as a result of the screening process. This level of research will be done on a limited number of candidates to learn more about each candidate's public profile and related information that is available on the internet.

### Preliminary Interviews via Video Technology

The Search Consultant will conduct preliminary interviews with the top group of candidates identified through the screening and preliminary research and Internet review processes. The interviews are extensive and designed to gain additional information about the candidates' experience, management style, and "fit" with the recruitment criteria. Interviews will be conducted using video technology.

The screening portion of the candidate evaluation process typically reduces a field of applicants to approximately four (4) to six (6) individuals. Those individuals will be reviewed with the City Council prior to proceeding with the individual interviews.

## Task 5 – Search Report

After completing Task 4, all documentation will be supplied to the City electronically. No hard copies will be supplied to the City for any phase of this search engagement. The Search Team will prepare detailed information for review including resumes uploaded to a file sharing system (i.e., DropBox or ShareFile). The Search Team will conduct a video conference call (using Zoom) with the City Council or other designated representative to review the search report on the top candidates. The report divides all of the candidates into four groups including 1) the top group of candidates that are recommended to be interviewed via video by the City Council; 2) a backup group to the first group; 3) no further consideration group; and 4) lacks minimum qualifications. The search report will include candidate resumes and cover letters. The results of preliminary media research will be included. This video meeting will result in a confirmed group of top candidates for the City to further consider.

Important to note, we do not conduct references on finalist candidates. We typically do so on only the selected top candidate. Periodically, we may recommend conducting references on the top two candidates to assist the governing body in the final selection and is done in the final stages of the search process. Verifications such as credit check, DMV Report and civil/criminal are typically conducted once a contingent offer is made to the selected candidate unless the finalist candidate(s) give explicit approval and sign a release to proceed. Verifications are not conducted on all finalists other than more standard education check before interviewing with the City Council.

The results of the Search Report will be a confirmed group of finalist candidates that the City Council will interview.

## Task 6 – Selection

The final selection process will vary depending upon the desires of the City Council. The typical services provided by Ralph Andersen & Associates in the selection process are described briefly below:

- The Search Team will coordinate the selection process for the finalist group of candidates. This includes handling the logistical matters with candidates and with the City.
- Ralph Andersen & Associates will prepare an electronic interview booklet (uploaded to a file sharing program such as DropBox or ShareFile) that includes the resume, cover letter, and preliminary media research for each candidate. In addition, this electronic information will contain suggested questions and areas for discussion based upon the recruitment criteria. Electronic copies of the interview booklet will be provided in advance of the candidate interviews. No hard copies of material will be provided. Should the City desire hard copies, a supplemental cost may apply.
- The Search Team will facilitate the Interviews to assist the City through the selection process. This assistance will include an initial orientation, candidate introductions, and facilitation of discussion of candidates after all interviews have been completed.
- Additionally, verifications will be made on the top candidate (or no more than two) and will include education verifications (if not conducted previously), Department of Motor Vehicle check, and credit check. Due to legislation, criminal checks (“Ban the Box”) are only permissible when a contingent offer of employment is made unless candidates give expressed permission to do so. The results of these verifications will be discussed with the City at the appropriate time.
- Reference checks will be conducted on the top candidate. The results of these reference checks will be discussed with the City Council at the appropriate time during a closed session.
- As needed, the Search Consultant is available to provide assistance to the City Council in the final selection as may be desired. This assistance may include providing or obtaining any additional information desired to assist in making the final selection decision.

## Task 7 – Negotiation

The Search Team is available to assist the City Council in negotiating a compensation package with the selected candidate. This includes recommendations on setting compensation levels.

Additionally, if desired by the City Council, Ralph Andersen & Associates will coordinate with the City Attorney to prepare a draft employment agreement and work with the Mayor and City Council on the finalization of this document. As required by the Brown Act, the employment agreement for the new City Manager will be required to be approved and voted on in a public meeting at a regularly scheduled City Council meeting.



## Task 8 – Close Out

After the City has reached agreement with the individual selected for the position, the Search Consultant will close out the search. These activities will include advising all of the finalist candidates of the status of the search by telephone.

## Strategy for Recruitment of Diverse Candidates

To Ralph Andersen & Associates, the diversity of the candidates we present to our clients is a very important metric that helps measure the success of our search. We also believe an equally important measure of success is whether the client has a choice among men and women of various ethnic backgrounds on the list of finalist candidates.

### Brochure

The brochure not only outlines the recruitment criteria, but it builds a visual identity that communicates the importance of diversity within the recruitment. Images used in the brochure should reflect the various ranges of diversity that exist within the organization and the community.

### Targeted Outreach to Minority Candidates

Outreach to traditional associations primarily dedicated to the advancement of equity and justice for their members is a strong source for minority and female candidates. Personal contacts within these types of organizations will assist the firm by identifying top talent within their respective memberships, which will result in a more diverse candidate pool for the position. The Project Director's focus will include specific outreach to members of the National Forum of Black Public Administrators (NFBPA), Society of Hispanic Professional Engineers, National Society of Black Engineers, and National Association of Women in Construction (NAWIC).

Ralph Andersen & Associates has a presence on LinkedIn, Twitter, and Facebook and uses social media to reach potential candidates.

Ralph Andersen & Associates is very proud of our track record with minority and female placements. A copy of Ralph Andersen & Associates' Women and Minority placements has been provided as an attachment to this proposal.

# Project Timing

We anticipate a timeframe of approximately 90 days (or less) from the execution of the agreement between the City and Ralph Andersen & Associates to when the finalists are presented for an interview. Negotiation with the top candidate will take an additional week after finalist interviews.

A brief overview of the recruitment schedule is presented below (schedule does not include transition time by Selected Candidate to join the City).

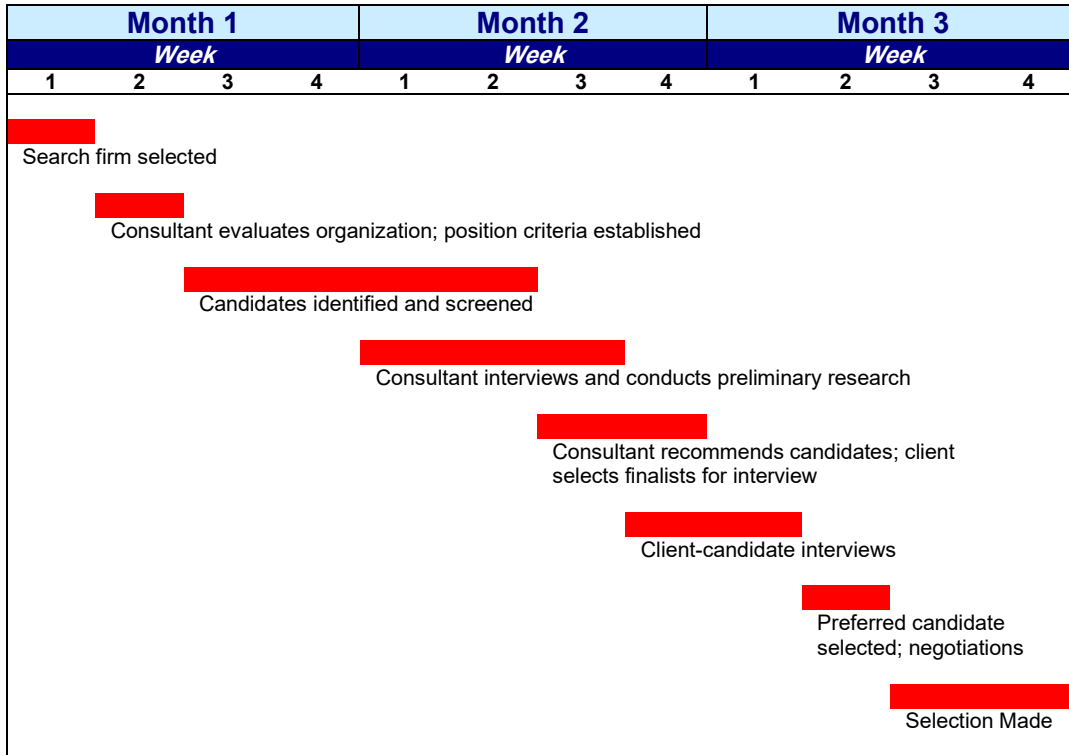

# Sample Work Products

## Sample Brochures

The following sample recruitment brochures are attached for your reference:

- City of Los Altos – City Manager
- City of Sierra Madre – City Manager

Ralph Andersen & Associates' digital presence is the best in the industry. We invite the City to view our website at [www.ralphandersen.com](http://www.ralphandersen.com) for other examples of our work products. More than ever, candidates are exploring opportunities digitally versus in print and it is critically important that candidates are not only presented with complete information but also a visually appealing format that showcases the career opportunity.

## Sample Candidate Presentation Packet

The candidate assessment tools prepared by Ralph Andersen & Associates are customized for each recruitment. However, the City should expect to receive the following:

- Resume Review Binder that includes a listing of:
  - All Applicants showing name and current position
  - Matrix of Experience for those candidates that are in the Highly Qualified group for an “at a glance” comparison of the top candidate’s experience and qualifications
  - Applicants in the Highly Qualified group along with their cover letter and resume
  - Applicants in the Meets Minimum Qualifications group along with their cover letter and resume
  - Applicants in the Lacks Minimum Qualifications group (no cover letters or resumes typically provided)
- Interview Binder
  - Interview Schedule
  - Suggested Interview Questions
  - Matrix of Experience
  - Application packet for each finalist candidate that typically includes:
    - Cover Letter
    - Resume
    - Responses to Supplemental Questions/Writing Sample

# Project Cost

The recruitment effort for a new City Manager will be a comprehensive search process with a focus in California and the Western Region. The review of resumes and qualifications will be conducted on all candidates that submit giving the City the ability to select from a broad field of qualified candidates. The professional services fee to perform this search will be a **fixed fee of \$31,500\*** for recruitment services and all related expenses.

**\*Note** – Expenses included in this fixed fee include such items as advertising, consultant interaction (most meetings to be done through video conferencing although some meetings may be done in-person by Mr. Wilson), clerical, graphic design, research, and long-distance telephone charges. On top candidates, Internet and Lexis/Nexis searches will be conducted. Additionally, education verifications, DMV check, wants and warrants, civil and criminal litigation search, and credit check will be conducted on the top two candidates. Reference checks will be conducted on the top candidate. Should the City desire to conduct reference calls on more than one candidate, a background fee of \$1,800 per candidate will be billed in addition to the above stated fees.

**Invoicing for Services** – Ralph Andersen & Associates will bill the City in four installments as follows:

- Following kick-off and finalization of recruitment brochure – \$9,450
- After the closing date – \$9,450
- After finalist interviews – \$9,450
- Upon placement – \$3,150

Progress payments will be due upon receipt.

**Brochure** – A full color electronic brochure will be developed for the City Manager recruitment. All pictures will be the responsibility of the City.

**Optional Services (Community Survey)** – Should the City choose to conduct a Community Survey with summarized results, this would be conducted for an additional \$3,500. This pricing structure includes an expedited survey process. Important to note, the City of Menlo Park will aid in circulating the survey through their standard citywide distribution list and by posting a link on the City's website.

**Exception** – Any candidate travel is the full responsibility of the City for on-site interviews anticipated to be in the final interviews (Round #2).

## Standard Hourly Billing Rates

As requested, Ralph Andersen & Associates' standard hourly billing rates are as follows:

- |  |           |
|--|-----------|
| • Project Director / Project Co-Director | \$175/hr. |
| • Recruitment Coordinator                | \$80/hr.  |
| • Graphics Designer                      | \$75/hr.  |
| • Researcher                             | \$60/hr.  |
| • Support Services                       | \$50/hr.  |

## Guarantee

Ralph Andersen & Associates offers the industry-standard guarantee on our full search services. If within a one-year period after appointment, the City Manager resigns or is dismissed, we will conduct another search free of all charges for professional services. The City would be expected to pay for the reimbursement of all incurred expenses.

If a placement is not made in the first outreach effort, the Consultant will conduct a second outreach effort with no charge for Professional Services. The City would be expected to pay for all incurred expenses.



# Comprehensive Listing of Women and Minority Placements 1972 through Present

Updated June 30, 2021

---

Agency	Position	Race	Sex
Alameda-Contra Costa Transit District, CA	Purchasing and Stores Manager	Hispanic	M
	Customer Information Supervisor	African American	F
Alameda, CA	County Librarian	White	F
Alameda County, CA	Chief Technology Officer	Asian	M
	Director of Child Support Services	African American	F
	Deputy Director – Building Maintenance Division	Asian	M
	Director of Health Care Services	White	F
	Fire Chief	African American	M
	HRS Labor Relations Manager	Hispanic	F
Albuquerque, NM	ABQ BioPark Chief Executive	African American	M
Alhambra, CA	General Manager	Hispanic	M
Alexandria, VA	City Manager	African American	M
	Director of Human Resources	Hispanic	F
Alpine County, CA	County Administrative Officer	White	F
	Health & Human Services Director	American Indian	M
Anaheim, CA	Budget Manager	Asian	F
	City Treasurer	White	F
	City Engineer	Hispanic	M
	Economic Development Manager	Hispanic	F
	Construction Services Manager	Hispanic	M
Arapahoe County, CO	Director of Finance	White	F
Arlington, TX	Director of Finance	White	F
	Director of Workforce Services	White	F
	Human Resources Director	African American	F
	Public Works and Transportation Director	White	F
Arvada, CO	Assistant City Manager	White	F
Association of Bay Area Governments (ABAG), CA	Risk Manager	African American	M
Association of Regional Center Agencies, CA	Executive Director	White	F
	Executive Director	White	F

*A Tradition of Excellence Since 1972*



<b>Agency</b>	<b>Position</b>	<b>Race</b>	<b>Sex</b>
Austin, TX	Assistant City Manager for Economic Opportunity & Affordability	Hispanic	
	Assistant City Manager for Health & Environment and Culture & Lifelong Learning	African American	M
	Assistant City Manager for Health & Environment and Culture & Lifelong Learning	African American	M
	Assistant City Manager for Health & Environment and Culture & Lifelong Learning		F
	Building Services Officer	African American	M
	Chief Information Officer		M
	Deputy CIO (Chief Technology Officer)	African American	F
	Deputy City Manager	Asian	M
	Director of Parks and Recreation	Hispanic	M
	Director of Housing and Community Services	African American	F
Director of Financial Services	Hispanic	M	
Public Works Director	White		
		Hispanic	
Austin-Travis County Sobriety Center	Executive Director	White	F
Azusa, CA	Director of Human Resources & Risk Management	White	F
Baltimore, MD	Chief Information Officer	African American	M
	Deputy Director of Finance	African American	M
	Director of Finance	African American	M
	Director of Social Services	African American	M
Bay Area Water Supply & Conservation Agency	Chief Executive Officer – General Manager	White	F
Bay County, FL	County Manager	White	F
Bedford, TX	City Manager	White	F
Bellevue, WA	Chief Economic Development Officer	Hispanic	M
Belvedere, CA	Planning Director (City Planner)	White	F
Berkeley, CA	Director of Information Technology	Indian	F
	Information Systems Manager	African American	M
Berkeley Housing Authority, CA	Executive Director	African American	M
Beverly Hills, CA	Assistant Director of Administrative Services / Human Resources	White	F
	City Manager	Middle Eastern	M
	Human Resources Manager	White	F
	Assistant Director of Administrative Services / Finance	White	F
	Assistant Director of Human Resources	White	F
	Deputy City Manager	Asian	F
	Director of Community Services	White	F
Big Bear City Community Services District	General Manager	White	F



<b>Agency</b>	<b>Position</b>	<b>Race</b>	<b>Sex</b>
Big Bear Lake, CA	Finance Manager	White	F
Bishop, CA	Chief of Police	White	M
Boise, ID	Chief of Police	Asian	M
Brea, CA	Assistant City Manager	White	F
	Personnel Director	White	F
Bremerton Housing Authority	Executive Director	White	F
Broward County, FL	Port Everglades Director of Finance	White	F
	Director of Economic and Small Business Development	African American	M
	Assistant Director of Enterprise Technology Services	White	F
	President/Director of the Greater Fort Lauderdale Convention and Visitors Bureau	White	F
Brownsville, TX	City Manager	Hispanic	M
Calaveras County, CA	Deputy Director Public Works for Engineering	Hispanic	M
	Health & Human Services Agency Director	White	F
California Fair Services Authority	Executive Director	White	F
California State University, Office of the Chancellor	Director, Emergency Management & Continuity	White	F
California Water Fix (Delta Conveyance Design & Construction Authority)	Executive Director	White	F
Camarillo, CA	Director of Finance	White	F
Carmel-by-the Sea, CA	Community Planning and Building Director	White	F
	Assistant City Administrator	White	F
Carrollton, TX	Assistant City Manager	African American	M
Cedar Hill, TX	City Manager	African American	M
Ceres, CA	Director of Administrative Services	White	F
Cerritos Community College District, CA	President/Superintendent	White	F
Charlotte, NC	City Manager	African American	M
	Director of Planning	African American	M
	Fire Chief	African American	M
	Chief Information Officer	African American	F
	Chief Financial Officer	White	F
	Chief of Police	African American	M
Chino, CA	Assistant City Manager	White	F
	Personnel Administrator	White	F





<b>Agency</b>	<b>Position</b>	<b>Race</b>	<b>Sex</b>
Cincinnati, OH	City Manager	African American	M
	Water Works Director	African American	F
	Director of Recreation	African American	M
	Fire Chief	African American	M
	Commissioner of Health	African American	F
Clovis, CA	Director of Planning & Development Services	White	F
Columbus, OH	Police Chief	African American	F
Colton, CA	Assistant Public Works & Utilities Director	Asian	F
Concord, CA	City Manager	White	F
	Personnel Director	White	F
Contra Costa County, CA	Executive Director, Housing Authority	Hispanic	M
Contra Costa Mosquito & Vector Control District	General Manager	Hispanic	F
Compton, CA	Controller	White	F
Corpus Christi, TX	City Manager	Hispanic	M
Corpus Christi Housing Authority	Vice President Rental Housing	White	F
	Deputy Chief Financial Officer	African American	M
Costa Mesa, CA	City Manager	African American	F
	Budget & Purchasing Manager	White	F
Cupertino, CA	Assistant Director Community Development	Asian	M
	City Manager	Asian	F
Davis, CA	Director of Personnel	Asian	M
	Director of Community Development	African American	M
Dallas, TX	Assistant Director Mobility & Street Services	White	F
	Chief of Police	African American	F
Dallas Area Rapid Transit Authority, TX	Assistant Director of Mobility Planning	African American	F
	General Counsel	Hispanic	M
Dallas/Fort Worth International Airport	Human Resources Director	White	F
	Vice President, Human Resources	African American	M
Dallas Housing Authority	Chief Financial Officer	African American	M
Delray Beach, FL	Utilities Director	Asian	M
	Budget Manager	African American	F
Denton, TX	Assistant City Manager	White	F
	Assistant General Manager of Power Supply	White	M
	Police Chief	African American	M
Douglas County, NV	Chief Technology Officer	White	F
Dublin San Ramon Services District	Engineering Services Manager	White	F
	Administrative Services Manager	White	F
	Assistant General Manager	Caucasian	F
East Bay Dischargers Authority, CA	Assistant General Manager	Asian	M



<b>Agency</b>	<b>Position</b>	<b>Race</b>	<b>Sex</b>
East Bay Municipal Utility District, CA	Personnel Manager	Asian	M
East Bay Regional Park District	Chief Human Resources Officer	White	F
	Chief of Design & Construction	White	F
East Palo Alto, CA	City Attorney	Hispanic	M
East Palo Alto Sanitary District, CA	General Manager	African American	M
Eastern Municipal Water District	Assistant General Manager of Finance and Administration	White	F
	Controller	Pacific Islander	F
	Senior Director of Water Resources Planning	White	F
El Campo, TX	City Manager	White	F
El Centro, CA	Personnel Director	White	F
El Dorado Hills Fire Department	Fire Chief	African American	M
El Paso, TX	Transportation Director	Hispanic	M
	Public Health Director	Hispanic	M
	Redevelopment Manager	Hispanic	F
	Human Resources Assistant Director	Hispanic	F
	City Engineer	Asian	M
	Comptroller	Hispanic	F
El Paso Water Board, TX	General Manager	Hispanic	M
Elk Grove, CA	Assistant Chief of Police	African American	M
Eloy, AZ	City Manager	Hispanic	F
Elsinore Valley Municipal Water District, CA	General Manager	Hispanic	M
	Assistant General Manager of Engineering & Operations	Asian	M
Emeryville, CA	City Manager	Hispanic	M
	Chief of Police	White	M
		Hispanic	M
Encinitas, CA	City Manager Water Operations Manager	White	F
Eugene, OR	Chief Financial Officer	White	F
Evanston, IL	Police Chief	African American	M
Evansville Housing Authority, IL	Executive Director	African American	M
Fairfield, CA	Personnel Officer	Hispanic	F
Flagstaff, AZ	City Attorney	Hispanic	F
	City Attorney	White	F
Forney, TX	Finance Manager	White	F



<b>Agency</b>	<b>Position</b>	<b>Race</b>	<b>Sex</b>
Fort Lauderdale, FL	Employment Manager	Indian	F
Fort Worth Housing Authority, TX	President	African American	F
Fountain Valley, CA	City Manager	White	F
Franchise Tax Board, State of California	Executive Officer	Other Minority	F
Fresno, CA	Police Chief	African American	M
Fullerton, CA	Public Works Director	White	F
	Director of Administrative Services	Asian	F
Garden Grove, CA	Community & Economic Development Director	Asian	F
Goleta, CA	Deputy City Manager	Hispanic	F
	Deputy City Manager	White	F
Grand Prairie, TX	Personnel Director	White	F
Greensboro, NC	City Manager	African American	F
Grover City, CA	City Administrator	White	F
Harlingen, TX	City Manager	Hispanic	F
Hayward, CA	Chief of Police	African American	M
Henderson, NV	Chief of Police	African American	F
Hercules, CA	City Manager	African American	M
Housing Authority of Santa Clara County, CA	Executive Director	White	F
	Senior Project Manager	White	F
Huntington Beach, CA	Director of Community Development	White	F
Indio, CA	City Manager	Hispanic	M
Indio Water Authority, CA	General	White	F
Inland Empire Utilities Agency, CA	Manager of Finance & Accounting	White	F
Irvine, CA	Community Development Director	White	F
	Administrative Services Director	Asian	F
	Assistant City Manager	Asian	F
Irvine Ranch Water District, CA	Executive Director of Finance & Administration	White	F
	Director of Human Resources	White	F
Kalamazoo, MI	Human Resources Director	White	F



<b>Agency</b>	<b>Position</b>	<b>Race</b>	<b>Sex</b>
Kansas City, MO	Administrator of the Municipal Court	White	F
	Chief Innovation Officer	White	F
	Development Services Manager (Senior Planner)	White	F
Kaufman, TX	City Manager	Hispanic	M
King County, WA	Public Health - Chief Financial Officer	Asian	F
	Environmental Marketing Manager	White	F
	Assistant Division Director, Solid Waste	White	F
	Construction Management Supervisor	Asian	M
	Sustainable Resources manager	White	F
King County Housing Authority	Deputy Executive Director for Administration	White	F
Kingsville, TX	City Manager	Hispanic	M
Lafayette, CA	City Manager	White	F
Lake Elsinore, CA	City Manager	Hispanic	M
Lake Forest, CA	City Manager	White	F
LAMP Community	Executive Director	White	F
Lane County, OR	Corrections Division Director (Jail Commander)	African American	M
Las Vegas, NV	Director, Department of Public Safety	Hispanic	M
Lathrop, CA	Community Development Director	White	F
Lawrence-Douglas County Housing Authority, KS	Executive Director	White	F
Lincoln	City Attorney	White	F
Los Altos, CA	Police Chief	White	F
	Police Chief	Other	M
	Administrative Services Director	African American	M
	City Manager	Hispanic	M

<b>Agency</b>	<b>Position</b>	<b>Race</b>	<b>Sex</b>
Los Angeles, CA	City Administrative Officer	Hispanic	M
	City Clerk	White	F
	Deputy City Engineer	White	F
	Director of Finance	African American	F
	Director of Public Works	African American	M
	Executive Director, Department of Cultural Affairs	White	F
	Fire Chief	Hispanic	M
	General Manager, Department of Transportation	White	F
	General Manager, Housing and Community Investment Department	Hispanic	M
	General Manager, Information Technology Agency	Hispanic	M
	Hyperion Treatment Plant Manager, Bureau of Sanitation	African American	M
	Nurse Manager	White	F
	Treasurer	African American	F
	GM/Director, Bureau of Street Services	Asian	M
Los Angeles, CA Department of Recreation and Parks	General Manager, Recreation and Parks	White	F
	Executive Officer	White	F
	Assistant General Manager, Planning & Construction	White	F
	Assistant General Manager, Region Operations	Hispanic	M
Los Angeles, CA Department of Water and Power	Chief Information Officer	African American	M
Los Angeles, CA Office of Public Accountability	Utility Rates & Policy Specialist III/Deputy Director	White	F
	Utility Rates & Policy Specialist III/Deputy Director	Hispanic	M
Los Angeles City Employees' Retirement Systems (LACERS), CA	Chief Investment Officer	Pacific Islander	M
Los Angeles County, CA	Chief Administrative Officer	Asian	M
	Public Defender	African American	M
Los Angeles County Office of Education	General Counsel	Hispanic	F
Los Angeles County Employees Retirement Association (LACERA), CA	Director of Retiree Health Care Benefits	Hispanic	F
	Director of Retiree Health Care Benefits	African American	F
Los Angeles County Transportation Commission, CA	Director of Finance and Administration	Hispanic	M
Los Angeles to Pasadena Metropolitan Blue Line Construction Authority	Chief Administrative Officer	Other	M
	Chief Financial Officer	Other	F

<b>Agency</b>	<b>Position</b>	<b>Race</b>	<b>Sex</b>
Los Angeles Unified School District	Director of Facilities Contracts	Hispanic	M
	Director of Facilities Contracts	African American	M
	Senior Resident Construction Engineer	African American	M
	Senior Resident Construction Engineer	White	F
	General Counsel	Asian	F
Los Angeles World Airports	Concessions Manager	White	F
	Deputy Executive Director, Business Development	Asian	M
	Deputy Executive Director, Design, Engineering and Construction	White	F
	Deputy Executive Director, Finance Executive Director	Asian White	M F
Los Banos	City Manager	Hispanic	M
Lynwood, CA	Finance Director	African American	F
	Director of Human Resources	African American	M
Madera County, CA	Human Resources Director	Hispanic	F
	Library Director	Caucasian	F
Maricopa County, AZ	Director of Animal Care & Control	Hispanic	M
	Executive Director, Department of Public Health	African American	F
	Public Works Director	African American	M
Marin County, CA	Assistant Director of Finance	White	F
	Chief Operations Officer (Health & Human Services)	White	F
	Director of Cultural & Visitor Services	White	F
	Director of Parks & Open Space	White	F
	Public Defender	Hispanic	M
	Human Resources Director	Asian	F
	Human Resources Manager	African American	F
	Chief Information Officer	White	F
	Chief Assistant Director of Information Services & Technology	Hispanic	M
Public Works Director	Hispanic	F	
Marin Municipal Water District	Human Resources Manager	African American	F
Martinez, CA	Chief of Police	Asian	M
	Finance Manager	Asian	F
McKinney, TX	City Manager	African American	M
	Administrative Services Director	African American	F
Menifee, CA	Finance Director	White	F
Metro Gold Line Foothill Extension Construction Authority, CA	Director of Public Affairs	White	F
Metropolitan Transportation Commission, CA	Director, Electronic Fares Program	White	F
	General Counsel	White	F
	Senior Counsel	White	F
	Senior Counsel	White	F
	Section Director, Finance & Accounting	White	F
	Section Director, Funding Policy & Programs	White	F
Metropolitan Washington Airports Authority	Assistant Fire Chief	White	F
	Fire Chief	White	F

<b>Agency</b>	<b>Position</b>	<b>Race</b>	<b>Sex</b>
Miami Beach, FL	City Manager	Hispanic	F
Midpeninsula Regional Open Space District	General Counsel	White	F
	Assistant General Manager – Planning & Project Management	Asian	F
Millbrae, CA	Public Works Director	Asian	M
	Public Works Director	Asian	M
Milpitas, CA	City Manager	Hispanic	M
Modesto, CA	Deputy Director of Personnel	White	F
	Public Works Director	Asian	M
	Director of Community and Economic Development	White	F
	Director of Human Resources	Hispanic	F
	Deputy City Manager – Operations	African American	F
Mono County, CA	County Administrative Officer	White	F
	Director of Finance	White	F
Monterey County, CA	Personnel Director	Hispanic	M
	Health Officer	Hispanic	M
Monterey County Schools Insurance Group, CA	Executive Director	White	F
Montgomery County, OH	Director of Public Works	African American	M
Moorpark, CA	City Manager	African American	M
Morgan Hill, CA	Assistant City Manager for Community Development	White	F
	City Manager	White	F
Morro Bay, CA	Chief of Police	African American	M
Napa County, CA	Director of Conservation Development & Planning	White	F
	Director of Corrections	White	F
	Assistant County Executive Officer	White	F
	Health & Human Services Agency Director	Asian	F
	Communications and Public Information Officer	White	F
Napa County Transportation & Planning Agency	Transportation Program Manager	Hispanic	F
Natividad Medical Center, CA	Associate Administrator of Nursing Services	White	F
Nevada County, CA	County Counsel	White	F
	Community Development Agency	White	F
New Braunfels, TX	Director of Parks & Recreation	White	F
New Mexico Finance Authority	Chief Regulatory Compliance Officer	White	F
	Chief Financial Officer	Hispanic	M
North Marin Water District	Chief Financial	White	F
Northwest Fire District	Business Service Director/CFO	White	F
Oak Park, IL	Director of Human Resources	African American	F



<b>Agency</b>	<b>Position</b>	<b>Race</b>	<b>Sex</b>
Oakland, CA	City Administrator	White	M
	City Administrator	Hispanic	F
	Fire Chief	African American	F
	Police Chief	White	F
	Budget Administrator	Asian	F
	Director of Finance	African American	F
Ocean Reef Community Association	President	Hispanic	M
Orange County, CA	Chief Human Resources Officer	White	F
Orange County, Fl	Utility Construction Manager	Hispanic	M
	Deputy Fire Chief	African American	M
	Manager of the Office of Management & Budget	White	F
Orange County Fire Authority, CA	Assistant Fire Chief – Fire Marshal	White	F
	Assistant Fire Chief – Human Resources Director	African American	F
	Human Resources Manager	White	F
Orange County Water District, CA	General Manager	White	F
Oregon State Bar, OR	Executive Director	White	F
Oxnard, CA	City Manager	Hispanic	M
	Finance Director	Hispanic	M
Oxnard School District, CA	Assistant Superintendent for Human Resources	Hispanic	M
Pacific Grove, CA	Police Chief	White	F
Pacifica, CA	Director of Recreation	White	F
Palm Desert, CA	City Manager	White	F
Palm Springs, CA	City Clerk	Hispanic	M
	Director of Finance & Treasurer	White	F
	Director of Parks & Recreation	Hispanic	F
	Director of Building & Safety	Hispanic	M
	Asst. Director of Maintenance & Facilities	Hispanic	M
Palo Alto, CA	Assistant Personnel Officer	White	F
	Chief Communications Officer	White	F
	City Auditor	White	F
	Finance Director	White	F
	Fleet Manager	Hispanic	M
Peralta Community College District, CA	College President, College of Alameda	African American	F
Pasadena, CA	Director of Communications	White	F
	Director of Public Works	White	F
	Director of Public Works and Transportation	White	F
	Director of Human Resources	African American	F
Pasadena City College, CA	Superintendent/President	Indian	M
Paso Robles, CA	City Manager	Hispanic	M
	Assistant City Manager	White	F



<b>Agency</b>	<b>Position</b>	<b>Race</b>	<b>Sex</b>
Petaluma, CA	City Clerk	White	F
Phoenix, AZ	City Engineer	African American	M
Phoenix Sky Harbor International Airport	Assistant Aviation Director – Business Planning	African American	F
	Assistant Aviation Director – Operations	White	F
Pima County, AZ	County Manager	Hispanic	M
Planned Parenthood of Sacramento, CA	Executive Director	White	F
Pleasanton, CA	City Manager	White	F
Point West Bank, CA	Vice President/Business Banking Officer III	White	F
Port of Los Angeles, CA	Chief Information Officer	Asian	M
	Director of Environmental Management	African American	M
	Deputy Executive Director, Stakeholder Engagement	Asian	M
Port of San Francisco, CA	Chief Harbor Engineer	Asian	M
	Maritime Director	African American	M
Portola Valley, CA	Town Manager	Hispanic	M
Poway, CA	Director of Administrative Services	White	F
Rancho California Water District, CA	Assistant General Manager	White	F
Redondo Beach, CA	Director of Library Services	White	F
Redwood City, CA	City Attorney	White	F
Reno, NV	City Manager	White	F
	Director of Parks, Recreation & Community Services	White	F
Richardson, TX	Finance Director	Hispanic	F
Richmond, CA	Risk Manager	White	F
Riverside, CA	Director of Parks and Recreation	African American	M
	Chief Innovation Officer	White	F
	Community & Economic Development Director	Hispanic	M
	Fire Chief	African American	M
	Utilities General Manager	Asian	M
	Parks, Recreation, and Community Services Director	Hispanic	M
	Public Works Director	White	F
	Utilities Department - Assistant General Manager - Operational Technology	Middle Eastern	M
	Deputy Public Works Director, Field Operations	White	F

<b>Agency</b>	<b>Position</b>	<b>Race</b>	<b>Sex</b>
Riverside County, CA	Assistant Director of Public Social Services – Children’s Services Division	African American	F
	Assistant Director of Public Social Services – Administrative Services Division	White	F
	Assistant Director of Public Social Services – Self-Sufficiency Division	African American	F
	Agricultural Commissioner	Hispanic	M
	Assistant County Executive Officer – Human Resources	White	F
	Deputy County Executive Officer – Homelessness Solutions	White	F
Roseville, CA	Deputy City Attorney II	White	F
	Economic Development Director	White	F
Sacramento, CA	Assistant City Manager	Hispanic	M
	Chief of Police	African American	M
	City Attorney	Hispanic	F
	Assistant City Manager – Municipal Services	Hispanic	M
	Business & Revenue Manager	White	F
Sacramento County, CA	Director of Child, Family, and Adult Services	Hispanic	F
Sacramento Housing and Redevelopment Agency, CA	Housing Director	African American	M
Sacramento Metropolitan Air Quality Management District	Executive Director/Air Pollution Control Officer	Hispanic	M
Salem, OR	Chief of Police	White	M
St. Barnabas Senior Services	Executive Director	White	F
San Antonio, TX	City Manager	Hispanic	M
	Assistant Director of Planning and Community Development	African American	F
San Bernardino, CA	Director of Parks, Recreation and Community Services	African American	M
	Human Resources Director	White	F
	Director of Public Works	White	F
San Bernardino County, CA	Director of Risk Management	Hispanic	M
	Deputy Fire Chief	African American	M
	County Health Officer	Asian	M
San Bernardino County Employees’ Retirement Association	Senior Investment Officer	White	F
San Bruno, CA	City Manager	African American	M
	City Clerk	White	F
San Diego, CA	Deputy Directors	Several Minorities	F
San Diego Association of Governments	Independent Performance Auditor	White	F
San Francisco Arts Commission, CA	Director of Cultural Affairs	Hispanic	M



<b>Agency</b>	<b>Position</b>	<b>Race</b>	<b>Sex</b>
San Francisco International Airport (SFO)	Associate Deputy Director of Revenue Development	White	F
	Director of Finance	White	F
	Director of International Marketing and Aviation Development	White	F
	Enterprise Architect	African American	M
	Finance Director	Hispanic	F
	Managing Director, Finance	Asian	M
City & County of San Francisco (Superior Court of San Francisco)	Assistant Chief Executive Officer	White	F
	Chief Probation Officer (Adult)	White	F
	Chief Adult Probation Officer	White	F
	Director, Probation Services	White	F
	Workers' Compensation Director	White	F
City & County of San Francisco, CA	Director of the Office of Early Care & Education	White	F
	Director of Public Works	Other Minority	M
	Deputy Director for Engineering	Other Minority	M
	Chief of Police	African American	M
	Director of the Department of Technology/CIO	White	F
San Francisco Public Utilities Commission, CA	Health Service System Executive Director	White	F
	Assistant General Manager	Hispanic	M
San Jose, CA	General Manager	African American	M
	Associate City Attorney	African American	M
	Associate City Attorney	Hispanic	F
San Jose, CA	Associate City Attorney	White	F
	Finance Director	White	F
San Luis Obispo, CA	Finance Director	White	F
San Marcos, TX	Chief of Police	White	M
San Marino, CA	Library Director	White	F
San Mateo Mosquito and Vector Control District, CA	District Manager	White	F
Sanger, CA	City Manager	Hispanic	M
	Administrative Services Director	Hispanic	M
Santa Barbara, CA	City Attorney	Hispanic	F
Santa Barbara County, CA	County Executive Officer	White	F
Santa Clarita, CA	Community Development Director	White	F
	Building Official	Hispanic	M
Santa Monica, CA	Assistant Director of Finance	White	F
	City Parking and Traffic Engineer	Asian	M
	Chief of Police	White	F
Santa Monica Community College District, CA	Superintendent/President	African American	F
Santa Rosa, CA	Director of Recreation & Parks	White	F
	Deputy City Manager	Hispanic	F
	Director of Community Engagement	Hispanic	M
	City Attorney	White	F
	Director of Community Engagement	African American	F



<b>Agency</b>	<b>Position</b>	<b>Race</b>	<b>Sex</b>
Santee, CA	Personnel Manager	White	F
Schools Insurance Group	Executive Director	White	F
Scottsdale, AZ	CFO/Treasurer	White	F
Scotts Valley Water District, CA	General Manager	White	F
Seattle, WA	Office of Inspector General Director	White	F
	Community Police Commission – Executive Director	African American	F
Seattle City Light, WA	Energy Delivery Engineering Director	Asian	M
Sedona, AZ	City Manager	African American	M
Selma, CA	City Manager	Hispanic	M
Sewerage and Water Board of New Orleans	Executive Director	Asian	M
Sierra Community College District	Superintendent/CEO	Hispanic	M
Silicon Valley Regional Operability Authority (SVRIA)	Executive Director	White	F
Simi Valley, CA	City Attorney	White	F
Solano County, CA	Chief Probation Officer	White	F
	Public Defender	White	F
	Building Official	Middle Eastern	M
Solano Irrigation District, CA	Finance Director	White	F
Sonoma, CA	Deputy Finance Director	White	F
South Orange County Water Agency, CA	General Manager	White	F
South Padre Island, TX	City Manager	White	F
South San Francisco, CA	Community Redevelopment Director	White	F
	Public Works Director	Asian	M
Southern California Association of Governments	Director of Government and Public Affairs	African American	M
	Executive Director	Other	M
	Chief Financial Officer	Hispanic	F
	Deputy Director – Special Initiatives	White	F
Southern California Public Power Authority	General Counsel	White	F
Southwestern Community College District, CA	Vice President for Human Resources	African American	F



<b>Agency</b>	<b>Position</b>	<b>Race</b>	<b>Sex</b>
State of California Exposition Park	Park Manager	African American	F
Stockton, CA	Chief Financial Officer/Director of Administrative Services	White	F
	Deputy Municipal Utility Director – Wastewater	White	F
	Deputy City Manager II	African American	F
Sugar Land, TX	Human Resources Director	White	F
	Police Chief	White	F
Suisun City, CA	Redevelopment Marketing Director	Asian	M
Sunnyvale, CA	Accounting Officer	Asian	F
	Director of Finance	Asian	F
	Director of Human Resources	White	F
	Chief Information Officer	White	F
Sutter County, CA	Assistant County Administrator	White	F
	County Administrative Officer	White	F
	Personnel Director	White	F
Tahoe-Truckee Sanitation Agency, CA	General Manager	Asian	M
Tallahassee, FL	Planning Director	White	F
Tiburon, CA	Town Manager	White	F
Tucson, AZ	Economic Initiatives Director	White	F
	Director of Information Technology/Chief Information Officer	African American	M
Tucson Airport Authority	President/CEO	White	F
Tulare County, CA	Personnel Director	Hispanic	M
Tulsa, OK	Director of Planning	White	F
Turlock, CA	City Attorney	White	F
Turlock Irrigation District, CA	Chief Dam Safety Engineer	White	F
	General Manager	Asian	M
Tustin, CA	Community Development Director	White	F
Ukiah, CA	City Manager	White	F
Union City, CA	City Manager	White	F
	Finance Director	White	F
University of California, Davis	Associate Director of Facilities, Mechanical	Asian	M
	Chief of Police	Asian	M
University of California, Los Angeles	Chief of Police	Asian	M
University of California, San Diego	Director of Public Safety	White	F

<b>Agency</b>	<b>Position</b>	<b>Race</b>	<b>Sex</b>
Vallejo, CA	Chief of Police	African American	M
	City Attorney	White	F
	Planning Director	Handicapped	M
Valley Sanitary District	General Manager	White	F
Vancouver, WA	Assistant City Attorney III	White	F
	Chief Assistant City Attorney	White	F
	Deputy City Manager – Enterprise Services	White	F
Ventura, CA	Traffic Engineer	Asian	M
	Public Works Director	White	M
Ventura Regional Sanitary District	Director of Finance	Hispanic	M
	Director of Finance	Hispanic	F
Washoe County, NV	County Manager	African American	M
Watsonville, CA	City Manager	Hispanic	M
West Sacramento, CA	Director of Community Development	Hispanic	F
Western Fairs Association	Executive Director	White	F
Western Municipal Water District, Riverside, CA	Deputy Director (2)	White	F
	Human Resources Manager	White	F
Wichita, KS	Fire Chief	White	F
Wildlife Heritage Foundation, CA	Executive Director	White	F
Windsor, CA	Town Manager	White	F
Yolo County, CA	County Administrator	Asian	M
Yosemite Community College District	College President, Modesto Junior College	White	F
	President of Columbia College	White	F
	Vice Chancellor of Human Resources	White	F
Zone 7 Water Agency	General Manager	White	F



# City of **Los Altos**

C A L I F O R N I A

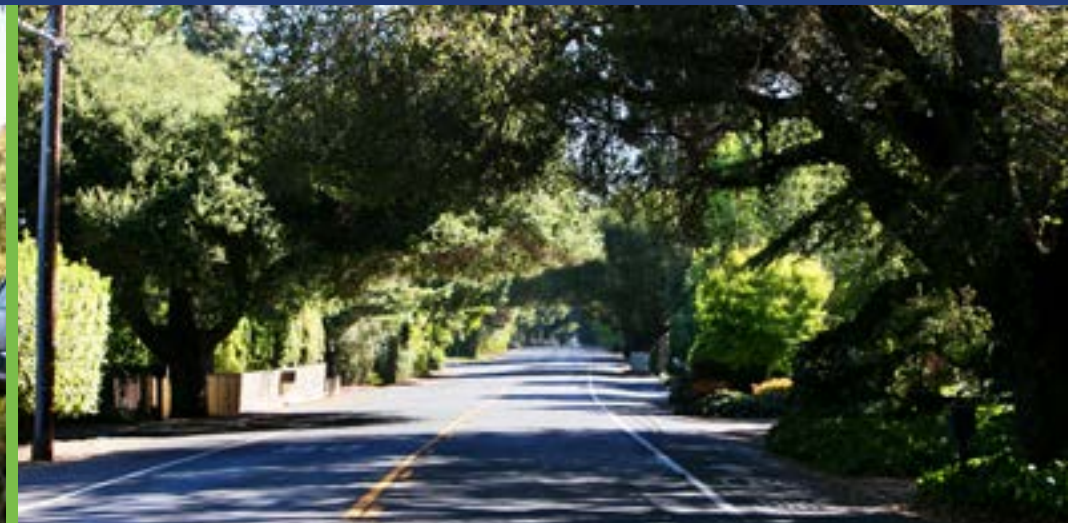

## **CITY MANAGER**

Recruitment Services Provided by Ralph Andersen & Associates

# A UNIQUE OPPORTUNITY

Known for its outstanding quality of life and small-town setting, the City of Los Altos is seeking a dynamic and accomplished executive to become its new City Manager. The City Council is looking for a candidate who would be a good fit for the community, a strong leader for City staff, and a successful partner with City Council. This top professional is expected to have exceptional leadership skills, effective interpersonal and communication skills, and a strong passion for public service. The selected City Manager will also need to have an inclusive management style combined with a hands-on approach to day-to-day operations. A thorough understanding of municipal finance, budgeting, community planning, and public works is of high importance to the City Council.

The City Manager will be faced with opportunities and challenges related to meeting the State affordable housing requirements, managing long-term capital improvement program priorities and projects, and overseeing existing City services and programs aimed at maintaining and enhancing the City's high quality of life for its residents. A strong candidate would be someone who thrives in an environment that has high expectations and demands high-quality work, has a collaborative approach, and is adept at applying best practices to managing municipal services.

In summary, the new City Manager will be charged with ensuring the organization continues to deliver excellent customer service and be responsive to an engaged and well-informed community, while working closely with a dynamic and forward-thinking City Council.





## THE COMMUNITY



Los Altos is a diverse and highly educated community. Residents have a long tradition of volunteerism, with many actively involved in City government and other community service organizations. Tree-lined streets and a small-village atmosphere characterize Los Altos, which is located in the heart of Silicon Valley. Just 40 miles south of San Francisco and 17 miles north of San Jose, Los Altos is an upscale residential community that blends a distinctive community-oriented character with the proximity and influence of the Bay Area's cultural, recreational, and business attractions. Many Silicon Valley executives, managers, and engineers choose to live in this City of over 30,000 because of its attractive climate, lovely neighborhoods, and charming downtown. Los Altos has been identified as a top Bay Area locale for families with children. Los Altos has a number of highly ranked schools that serve K-12 students, including schools recognized as California Distinguished Schools and National Blue Ribbon Schools. Its students consistently achieve the highest scores in the State on standardized tests. The community also includes excellent private schools. Foothill College as well as Stanford, Santa Clara, and San Jose State Universities are within close proximity to Los Altos.

Los Altos provides spacious lot sizes for residents to build or purchase their dream home, walkable neighborhoods, parks, and open space as well as seven neighborhood commercial areas that provide services to the community. The city is just completing construction of a new state of the art, sustainable \$37 million Community Center that will host recreational and educational opportunities. With its picturesque neighborhoods, downtown village, and highly-rated public and private schools, Los Altos is one of the premier residential communities on the San Francisco Peninsula and prides itself as an exceptional place to live, work, and raise a family.

# THE ORGANIZATION

Los Altos is a General Law City and operates under the Council/Manager form of government. The five members of the City Council are elected to four-year overlapping terms, with the Mayor selected among his/her peers to serve a one-year term. The City Council appoints the City Manager, who in turn, serves as chief executive of the municipal organization. The City also utilizes several standing volunteer commissions. The City relies upon these commissions as well as ad-hoc committees to advise City Council on community issues. The City of Los Altos is a full-service city with a total 2020 - 2021 budget of \$83.7 million (\$57.2 million operating budget), \$26.5 million FY 20-21 CIP, and \$886,000 for Debt Transfers. Current staffing includes 136 benefited FTEs and 51 part-time non-benefited FTEs. The City currently follows a 9/80 schedule with offices closed every other Friday. The City has its own Police Department and contracts for fire services with Santa Clara County Fire District. Notably, the City is financially stable with over \$50.8 million in General fund reserves primarily due to its property tax revenues. The City Council has a long-standing policy to hold at least a 20% general reserve in accordance with best practices in local government.



## The 2021 Goals adopted by the City Council are:

- 1. Housing:** The City of Los Altos will support the creation of housing that is diverse, equitable, and affordable for all income levels in the Community and support funding and legislation that will help the City to do so and also retain its flexibility in zoning decisions.
- 2. Land Use:** The City of Los Altos will implement policies that support a land-use mix and density that reflect the values of the Community, including seeking to protect and increase its green space, while ensuring compliance with any applicable laws and regulations.
- 3. Fiscal Sustainability:** The City of Los Altos will continue to be responsible financial stewards of its resources and assets to ensure long-term fiscal sustainability by practicing sound financial management and fiscal transparency, while providing fiscally sustainable government services that address the needs of the community.
- 4. Community Safety:** The City of Los Altos will continue to implement plans, strategies, and educational opportunities to ensure public safety, traffic safety, and emergency preparedness services are done in a responsive, equitable, professional, socially responsible, and trustworthy manner.
- 5. Asset Management:** The City of Los Altos will set clear expectations and allocate the necessary funding to maintain and improve City facilities and infrastructure that are necessary to provide high-quality services for the well-being of residents.
- 6. Environmental Sustainability:** The City of Los Altos will be a leader on environmental sustainability through education, and adopting and embracing policies, initiatives, and practices that advance this effort.
- 7. Community Engagement:** The City of Los Altos will continue to improve its community engagement process to ensure all community members are heard, informed, and included.
- 8. Transitioning Through Change:** The City Council will proactively address the impact of COVID-19 and other consequential changes on the community during 2020 and 2021 to ensure Los Altos successfully navigates these transitions to be an even stronger community.

# THE IDEAL CANDIDATE

The City Council is seeking a strategic, experienced, and innovative manager to employ a team approach to proactively address issues that impact the community. The new City Manager will also embrace the culture of the organization and continue to promote the values held by the community for responsive and efficient delivery of services. Approachability, attention to detail, patience, responsiveness, and follow-through are absolutely key to success in this community.

The City Manager will need to effectively develop and propose initiatives and creative solutions for the City Council's consideration and adoption. The City Council desires a manager who enjoys working in the public sector and appreciates contributions from all sources within the organization as well as the engaged community. Additionally, the City Manager will be expected to foster an open dialogue and strong lines of communication with staff and City Council. Having a City Manager who is respectful, collaborative, inclusive, and professional is also very important to the City Council. The City Manager should have unquestioned personal integrity, honesty, and strong ethics.

The ideal candidate will also possess the following characteristics:

- Genuine concern and appreciation for preserving the quality of life presently enjoyed by residents of Los Altos;
- Results-driven approach to municipal finance, public safety, and all aspects of municipal service delivery;
- Appreciation for exceptional customer service, effective and efficient operations, transparency, service delivery that exceeds community expectations, and overall community access;



## The Ideal Candidate *continued*

- Open and accessible style that promotes candid discussions among Staff, Council, and Commissions and encourages the review of options and alternatives for the City Council's consideration;
- Ability to provide leadership to both the City Council and staff with the ability to set goals and objectives, motivate others, and contribute effectively to their timely achievement and successful performance; and
- Comfortable with and proficient in using technology.

The new City Manager will provide strong leadership and be primarily involved in:

- Balancing an array of community needs including continuing the high-level of transparent, frequent, and open communications;
- Addressing ongoing infrastructure needs, service delivery, public safety, and overseeing overall enhancements through effective planning and community development; and
- Establishing constructive relationships among the City Manager, staff, Council, commissions, and the community.

## EXPERIENCE AND EDUCATION

**Review of Qualifying Experience and Education:** The full City Council will be actively involved with Ralph Andersen & Associates in the screening and evaluation of resumes to determine the appropriate match of professional experience and education.

**Experience:** Candidates should demonstrate successful performance and advancement through progressively responsible experience in administrative, managerial, and/or staff positions. Experience working with an engaged elected body and community is strongly desired. All highly qualified candidates are strongly encouraged to apply. In an effort to find the most suitable candidate, the City Council will consider a broad spectrum of talented individuals.

**Education:** Ideally, candidates will have a Master's degree or other advanced degree from an accredited college or university with major course work in planning, public or business administration, or a closely related field.



# COMPENSATION

The City Council is prepared to offer a highly competitive salary for the region consistent with recent practices; salary appointment will be made depending on qualifications and experience of the selected candidate. A mutually agreeable employment agreement will be negotiated and may include relocation assistance for the selected candidate.

The benefits package offered by the City includes:

- **Retirement:** CalPERS retirement plan for Classic members is 2% @ 60 with employee paying a contribution of 7%. PEPRAs employees participate on a 2.0% @ 62 plan, with employee paying 6.75% of the retirement contribution. Benefits based on average of highest three years of compensation. The City *does not* participate in Social Security.
- **Health Benefits:** Choice of HMO or PPO medical plans through CalPERS Health Benefits with most family plans covered at 100%. Employees who waive coverage may receive stipend of \$350 per month.
- **Dental and Vision Reimbursement plan:** Employee and dependents receive reimbursements up to annual maximum.
- **Vacation Leave:** Prior years of experience from other public agencies may be cumulated to increase accrual rate.
- **Life Insurance:** City paid term life at 150% of salary; additional life insurance purchase option.
- **Holidays:** Ten observed holidays and one floating day annually.
- **Sick Leave:** Twelve days annually.
- **457 Deferred Compensation plans:** Voluntary participation in either Nationwide or ICMA-RC.
- **Flexible Spending Section 125 plans:** Dependent care and health care reimbursement.
- **Management Leave and other benefits will be negotiated with the successful candidate.**

Further details can be obtained through discussions with Ralph Andersen & Associates.



## TO BE CONSIDERED

Interested candidates should apply by submitting a compelling cover letter, comprehensive resume, and five professional references via email to [apply@ralphandersen.com](mailto:apply@ralphandersen.com) no later than **April 16, 2021**.

This is a confidential recruitment and will be handled accordingly throughout the various stages of the process. Candidates should be aware that references will not be contacted until mutual interest has been established.

Confidential inquiries are welcomed and should be directed to Fred Wilson, Ralph Andersen & Associates, at (916) 630-4900.

***The City of Los Altos is an equal opportunity employer.  
The City values diversity and encourages all qualified  
candidates to apply for consideration.***

**LOSALTOSCA.GOV**

THE CITY OF

# SIERRA MADRE

CALIFORNIA



## CITY MANAGER





# AN INCREDIBLE OPPORTUNITY!

Renowned for its outstanding quality of life and small-town setting, the City of Sierra Madre (population approximately 11,000) is seeking a dynamic and accomplished executive to join this financially healthy and well-managed organization. The City Council is seeking an engaging leader with exceptional interpersonal and communication skills and a strong passion for public service.

This leader will thrive in an environment that embraces an entrepreneurial spirit and approach to local government, sets high expectations, and demands a high level of customer service and responsiveness. The selected City Manager will also bring an inclusive management style combined with a hands-on approach to day-to-day operations, continuing to build on the extremely positive culture in the organization.

Additionally, this top executive will be a collaborative leader with exceptional interpersonal and communication skills. Known as a “people person,” this individual will value collaboration and strive for best practices in the delivery of services, while at the same time, invite and encourage community engagement. An open and approachable leadership style is strongly desired in order to relate well to a broad spectrum of stakeholders including staff, elected officials, business and community leaders, and, of course, an active community. This passionate leader will welcome input and value contributions from all sources yet be able to guide the policymakers with a strong sense of purpose.



# THE COMMUNITY

Sierra Madre is a geographically small city, approximately 3.5 square miles, located 12 miles northeast of Los Angeles. Nicknamed the “Village of the Foothills,” Sierra Madre borders Pasadena to the West, Arcadia to the South and East, and its largest shared border is with the Angeles National Forest to the North. The downtown area covers six city blocks and exhibits the small-town charm and character Sierra Madre is known for, with architecture and building styles that are representative of the 1930s - 1950s. The small business district and limited commercial zoning provide for a community that is nearly 100% residential.

Sierra Madre is known for its village ambience with serene neighborhoods, scenic views, and plentiful green and open space. At its heart is the City’s charming downtown shopping district, a popular destination for visitors and residents. Sierra Madre is a tight knit community that takes deep pride in its history, yet modern-day lifestyle.

Residents can partake in numerous recreational activities offered by the City at its six parks, Aquatic and Recreation Center, and the Hart Park House and Senior Center. City culture and history have been preserved through the Lizzie’s Trail Inn Museum, Richardson Historical House, and the Sierra Madre Public Library’s Local History Collection. Nature seekers are drawn to Bailey Canyon Wilderness Area and the Mount Wilson Trail, which lead hikers into the expanse of the Angeles National Forest.

To learn more about the City of Sierra Madre, please visit [www.cityofsierramadre.com](http://www.cityofsierramadre.com).



# ORGANIZATIONAL OVERVIEW

Incorporated in 1907, the City of Sierra Madre is a General Law City and operates under the Council/Manager form of government. Legislative authority is vested in a five-member City Council elected at large for four-year terms. Sierra Madre is one of the oldest and smallest cities in Los Angeles County. Despite its size, the government of Sierra Madre has always operated as a full-service City and provides residents with Public Safety services, including Police and Fire Departments as well as Water, Sewer, Public Library, and a wide array of community services. Residents of the city have an exceptional quality of life with median income, educational attainment, and property values that greatly exceed similar measures in peer cities in Los Angeles County and the State of California. Sierra Madre is routinely ranked as one of the top 20 safest cities in California and the residents are served by a fiscally sound, stable, and productive government, with annual operating surpluses in the City budget, CalPERS pension funding levels at nearly 90% for both the public safety and miscellaneous plans, and OPEB obligations funded at over 100%.

The City of Sierra Madre is a full-service city with a total 2021-2022 budget of \$24 million (\$22 million operating budget), \$6.1 million CIP, and \$350,200 for Debt and Payment Appropriations. Current staffing includes 84 benefited FTEs and 6 part-time non-benefited FTEs. The City has its own Police Department and Fire Department. The City currently follows a 9/80 schedule with offices closed every other Friday.

Importantly, the City is financially stable with over \$10.2 million in general fund reserves (95% of operating expenditures) and \$200,000 in general fund contingency. The City Council has a long-standing policy to hold a 25% general fund reserve in accordance with best practices in local government.



## STRATEGIC GOALS:

The City of Sierra Madre's strategic goals are determined and evaluated in conjunction with department goals, to ensure that each facet of the City works together to meet our core values. Below are the strategic goals, along with highlights of steps the City is making to meet those goals.

### *Improve and maintain traditional City infrastructure and green infrastructure*

- Updating master plans for Water, Stormwater, Sewer, and Streets.
- Completed agreement for 550 kW solar project at the City Yards.
- Budget FY 21-22 includes a capital budget for 2 miles of watermain replacement project and continued city street rehabilitation project

### *Increase the long-term water supply for its residents*

- Working with regional partners bolstered by Measure W funds to ensure the health and safety of our local watershed.
- Formalized an interagency agreement City of Arcadia for emergency water access.
- Initiated negotiations with City of Arcadia to establish a jointly-owned well in Main San Gabriel basin.

### *Increase professional development and retention of employees*

- Encouraging employees looking for development opportunities to participate in supervisory trainings and workshops.

### *Improve small-town government operations*

- Modernizing library services to include the newest media and technology.
- Installed automated meter infrastructure (AMI), allowing staff to read water meter remotely, and give residents ability to track and monitor water consumption.
- Secure and high-speed fiber connections for Public Safety, City Hall, and City Yard operations.
- Installing public access Wi-Fi at high-traffic points, with plans to expand at other sites city-wide.

## CORE VALUES:

Efficiency and effectiveness  
Honesty and integrity  
Financial accountability  
Teamwork  
Community participation  
Small town character

# THE CITY MANAGER'S OFFICE

The City Manager directs, coordinates, and manages the overall administrative activities and operation of the City and advises and assists the City Council while exercising significant independent judgment and initiative. The City Manager is appointed by the City Council and serves at its pleasure. The most recent City Manager accepted a new position in July 2021 after four and a half years in this leadership position. On an interim basis, the Utilities Services Director is serving in the role of City Manager until the search process concludes.



# THE IDEAL CANDIDATE

The City Council is seeking a creative and forward-thinking individual who is dedicated to promoting and enhancing the workplace culture and takes a proactive approach to problem solving and communication with the community. Additionally, the City Manager should have a genuine appreciation of the uniqueness of Sierra Madre and its values. The ability to develop and promote strategic initiatives for the City Council's discussion and consideration while incorporating best practices in local government are important qualities.

The City Manager will have a hands-on and collaborative approach to management with frequent interaction with department heads and staff, fostering an open dialogue. The City Council also desires a manager who also enjoys working in the public sector and appreciates the variety and diversity of contributions from all sources within the organization and from the community.

The City Manager should be a person who can successfully address a variety of issues at the highest levels using sound judgment. Top candidates for consideration will have a solid career track record of having unquestioned personal integrity, honesty, and strong ethics.



The ideal candidate will also possess the following characteristics:

- 👤 Be a proven leader with a passion for public service and the ability to work with the City Council to help achieve the goals of the community.
- 👤 Be a hands-on leader who engages directly with the initiative to solve challenges the community faces. This individual should have strong communication, organizational, and time management skills.
- 👤 Understand the importance of and be committed to the preservation and enhancement of resident quality of life.
- 👤 Possess strong budget and financial management skills and be able to maintain and improve upon the City's financial condition.
- 👤 Confident style that will promote candid discussions and encourage diversity of thought by providing an environment that listens intently to the community and emphasizes the review of options and alternatives for the City Council's consideration.
- 👤 Ability to provide leadership to both the City Council and staff, setting goals and objectives as well as motivating and contributing effectively to timely achievement and successful performance, all for the betterment of the community.
- 👤 Willingness to mentor and develop staff while fostering the strong interdepartmental coordination already in place. The successful candidate should be someone who has a hands-on approach without micromanaging and believes every aspect of local government is important.
- 👤 Commitment to the economic vitality of the community including support of a vibrant business community.
- 👤 Possess a track record of successful involvement with labor and employee relations issues.
- 👤 Valuing, empowerment, delegation, and celebration of the accomplishments of staff are important elements the new City Manager must bring to the organization.

# QUALIFYING EXPERIENCE AND EDUCATION

The City Council has established broad general guidelines for consideration of interested individuals.

**Education:** Bachelor's degree in business or public administration or a related field required; a master's degree in related field is desirable. Additionally, senior level local government management experience is desirable, including experience as City Manager, Assistant City Manager, or Senior Department Head with broad based responsibility.









**Experience:** This position requires a minimum of 3 to 5 years of progressively responsible experience in an administrative, managerial, or staff capacity in a comparable organization with similar complexities. California municipal experience is highly regarded by this City Council. All highly qualified candidates are strongly encouraged to apply. In an effort to find the most suitable candidate, the City Council will consider a broad spectrum of talented individuals with a preference for municipal service in California.





# COMPENSATION

The City Council is prepared to offer a highly competitive salary for the region consistent with recent practices plus executive level benefits including:

-  **Retirement:** CalPERS retirement plan for Classic members is 2.5% @ 55 with employee paying a contribution of 7%. Benefits based on single highest year of compensation. New PEPRAs members is 2% @62 with employee paying 7.25% of the retirement contribution, amount subject to change annually. The City does not participate in Social Security.
-  **Health Benefits:** Choice of HMO or PPO medical plans through CalPERS Health Benefits with most family plans covered up to \$18,000 annually by the City.
-  **Vacation Leave:** Prior years of experience from other public agencies may be cumulated to increase accrual rate.
-  **Life Insurance:** City paid term life insurance; additional life insurance purchase option.
-  **Holidays:** Ten (10) observed holidays and one (1) floating day annually.
-  **Sick Leave:** 96 hours annually.
-  **457 Deferred Compensation plans:** Voluntary participation in either Nationwide or ICMA-RC.
-  **Flexible Spending Section 125 plans:** Dependent care and health care reimbursement.
-  **Management Leave and other benefits will be negotiated with the successful candidate.**

Further details can be obtained through discussions with Ralph Andersen & Associates.



# TO BE CONSIDERED

Interested candidates should apply by submitting a compelling cover letter, comprehensive resume, and five professional references via email to [apply@ralphandersen.com](mailto:apply@ralphandersen.com) no later than **Monday, September 6, 2021**.

This is a confidential recruitment and will be handled accordingly throughout the various stages of the process. Candidates should be aware that references will not be contacted until mutual interest has been established.

Confidential inquiries are welcomed and should be directed to Fred Wilson, Ralph Andersen & Associates, at (916) 630-4900.

*The City of Sierra Madre is an Equal Opportunity Employer.*



[www.cityofsierramadre.com](http://www.cityofsierramadre.com)

Ralph Andersen & Associates  
5800 Stanford Ranch Rd, Ste 410  
Rocklin, California 95765  
Tel: 916.630.4900  
Fax: 916.630.4911  
[www.ralphandersen.com](http://www.ralphandersen.com)





CITY OF MENLO PARK • MENLO PARK, CA

# EXECUTIVE SEARCH SERVICES

CITY MANAGER  
08/04/2021

**SUBMITTED BY:**

THE HAWKINS COMPANY

Bill Hawkins, President & CEO

310-348-8800

[bill@thehawkinscompany.com](mailto:bill@thehawkinscompany.com)

[www.thehawkinscompany.com](http://www.thehawkinscompany.com)

*Executive Search Consultants  
Connecting Leaders; Affecting Change*



August 5, 2021

**CONFIDENTIAL**

Nira Doherty  
City Attorney  
City of Menlo Park  
Attn: RFP for City Manager Recruitment  
701 Laurel Street  
Menlo Park, California 94025

Via Email: [ndoherty@bwslaw.com](mailto:ndoherty@bwslaw.com)

Dear Mayor Combs and Members of the City Council:

We are extremely pleased to present our firm's proposal to assist the city recruit a City Manager to replace the retiring City Manager, Ms. Starla Jerome-Robinson.

*The Hawkins Company* is exceptionally well qualified to assist you with this very important executive search. We have extensive experience recruiting for public sector organizations. Since 1984, we have conducted over 800 executive recruitments for clients in the private, public and nonprofit sectors.

Our firm has been recognized for its ability to handle the most difficult and complex recruitments. We believe that the key to conducting successful searches for these key positions is achieving a profound understanding of the types of leaders needed to fulfill these positions. Such strategic personal consulting work is one of our strengths. Our approach is always to build a strong relationship with our client and to provide them with "best in class" talent and executive search services. You will find that we communicate with our client contact representatives frequently, typically by means of bi-weekly conference calls, as our search process unfolds.

8939 S. Sepulveda Blvd., Suite 110-216, Los Angeles, CA 90045, 310-348-8800  
11040 Bollinger Canyon Road, Suite E-216, San Ramon, CA 94582, 213-308-0945

*Executive Search Consultants*  
*Connecting Leaders; Affecting Change*

Decisions about qualified potential candidates are always made collaboratively, with an open mind and ear to the nuances of the client's needs. We are committed to providing great customer service with timely results.

One key factor which contributes to our success is our "private sector-direct sourcing" approach in conducting public sector recruitments. We believe that the application of private sector recruiting strategies and our industry knowledge will streamline the process and add value to the services we provide.

We offer state-wide coverage in immediately interacting with candidates throughout the state. We also possess a track record of conducting national recruitments and are committed to recruit "best in class" professionals and provide our clients with great customer service.

We are prepared and have the capacity to handle this key executive recruitment for the City of Menlo Park once a contract has been executed. We are anticipating one similar (chief operating officer for the City of San Diego) assignment beginning in mid-September

I will personally lead our firm's recruitment efforts on behalf of the city. The recruitment will be staffed by other staff who will work closely with me in the identification, recruitment, and evaluation of candidates who meet the core competencies for the City Manager position. Please be assured that the full resources of our firm will be employed on behalf of the city.

Please feel free to contact me at 310-348-8800 should you have any questions or need additional information. We look forward to hearing from you.

Sincerely,



William D. Hawkins  
President

8939 S. Sepulveda Blvd., Suite 110-216, Los Angeles, CA 90045, 310-348-8800  
11040 Bollinger Canyon Road, Suite E-216, San Ramon, CA 94582, 213-308-0945

*Executive Search Consultants*  
*Connecting Leaders; Affecting Change*

## EXECUTIVE SUMMARY

During the past thirty-seven (37) years, *The Hawkins Company* has been instrumental in completing over 800 executive searches assisting public and private organizations recruit strong and highly effective leaders in senior executive leadership positions. We have a strong public-sector practice where we have worked on behalf of city and county governments, and special districts throughout the United States. Most of our searches are national in scope which has afforded us an opportunity to develop a large database of candidates and sources of candidates throughout the United States. We take great pride in our ability to work effectively on behalf of our clients and our focus is always tailored to the unique staffing objectives and needs of our clients. Our approach is always to build a strong relationship with our client and to provide them with high quality executive search consulting services in a manner that reflects positively on their organization.

We are pleased with our ability to assemble teams of consultants with specific expertise and skills that contribute to the delivery of outstanding recruitment services. **The team's objective is to clearly understand client needs and candidate competencies required to ensure that we identify and recruit "best in class" professionals. As a result, we are often requested to assist clients with their most difficult and challenging recruitments.** We have a solid footprint in recruiting top level change agents and highly skilled transformational leaders to lead urban public agencies, municipalities, and special districts. Furthermore, we have a long history of successfully recruiting top-notch leaders for Bay Area organizations including the City and County of San Francisco, City and Port of Oakland, City of Berkeley, Sacramento County, Alameda County, BART, EBMUD, etc.

Our work experience (over 800 searches) allows us to maintain strong relationships with top level governmental, non-profit, education and private sector executives in most functional and geographical areas, and we will leverage these relationships to ensure that we identify and recruit "best in class" professionals on behalf of the City of Menlo Park. We are experts in recruiting talented executives and maintain a 90% placement rate.

With respect to city manager searches, we have done searches for large cities like Long Beach and Oakland, CA and smaller cities like Inglewood, Compton, and Fillmore, CA. We are comfortable with our ability to recruit strong talent in this area. Our forte is working for diverse urban communities. Our extensive contacts and speaking engagements experiences with the International City Managers Association (ICMA), League of California Cities, National Forum of Black Public Administrators (NFBPA), and International Hispanic Network afford us an extensive network of contacts in the city manager field nationally and regionally. Our experience working with elected officials and being responsive to their varied expectations has been one of our key strengths. We are experts in working in complex political environments without becoming political. We help elected officials develop solid strategies to meet their talent acquisition requirements and

8939 S. Sepulveda Blvd., Suite 110-216, Los Angeles, CA 90045, 310-348-8800  
11040 Bollinger Canyon Road, Suite E-216, San Ramon, CA 94582, 213-308-0945

*Executive Search Consultants*  
*Connecting Leaders; Affecting Change*

are trusted advisors. We take matching the needs of the Council with the talent of appropriate candidates without compromising trust and integrity. Our hands-on approach will add significant value to the City of Menlo Park. Our ability to think and operate creatively and work collaboratively with our client partners is a hallmark of our expertise and what we do. Finally, our willingness to deploy adequate staff resources will result in a timely, thorough, and successful executive recruitment for the City of Menlo Park.

8939 S. Sepulveda Blvd., Suite 110-216, Los Angeles, CA 90045, 310-348-8800  
11040 Bollinger Canyon Road, Suite E-216, San Ramon, CA 94582, 213-308-0945

*Executive Search Consultants*  
*Connecting Leaders; Affecting Change*



## **BACKGROUND & EXPERIENCE**

*The Hawkins Company*, established in 1984, is a management consulting firm specializing in executive search services. Long recognized as a leader in the field of executive recruitment, *The Hawkins Company* and its team have successfully conducted over 800 senior level talent acquisition assignments for public, private, nonprofit, and educational organizations with a consistent commitment to achieving the staffing objectives of our clients, quality of service, and “best in class,” candidate recruiting.

*The Hawkins Company* is exceptionally well qualified to assist with your talent acquisition needs for the following reasons:

- *The Hawkins Company* is one of the premier MBE, senior level executive search firms in the United States, and offers an unbiased professional approach in successfully completing executive search assignments.
- *The Hawkins Company* utilizes a tailored six-step process in conducting senior level search assignments for Fortune 500 corporations, small and medium size companies, municipalities, public agencies, educational institutions, nonprofits, and start-up organizations.
- *The Hawkins Company* has extensive experience working with elected officials, boards, top administrators, search committees, corporate executives, and human resources professionals in designing and implementing effective recruitment strategies.
- *The Hawkins Company* is committed to diversity, equity, and inclusion and maintains excellent relationships with various professional organizations and associations. *The Hawkins Company* takes pride in its record of promoting diversity, equity, and inclusion at every stage of the recruitment process. The firm has been recognized for its success in diversity recruiting.
- *The Hawkins Company* and its team of consultants have conducted senior level recruitments for a variety of government organizations, in major cities nationally. We are often selected to conduct highly visible, challenging and politically sensitive searches. This is clearly one of our core “sweet spots.”

8939 S. Sepulveda Blvd., Suite 110-216, Los Angeles, CA 90045, 310-348-8800  
11040 Bollinger Canyon Road, Suite E-216, San Ramon, CA 94582, 213-308-0945

*Executive Search Consultants*  
*Connecting Leaders; Affecting Change*

## **MISSION STATEMENT**

The mission of *The Hawkins Company* is to identify, cultivate, recruit, evaluate and deliver best in class executives that meet and exceed our clients' expectations with a commitment to diversity and inclusion. *The Hawkins Company's* objective is always to provide excellent customer service to our clients and to ensure that the candidate experience is exceptional.

*The Hawkins Company's* core values are:

- Human Capital is the most important asset in any organization.
- Integrity and service are the cornerstones that drives what we do.
- Treat everyone with dignity and respect. Be open at all times.
- Value our work product, be creative, and innovative while serving both clients and candidates.
- Take pride in what we do and always advocate for diversity, equity, and inclusion.

*The Hawkins Company's* objective is always to find the best-qualified candidates. We believe that, although advertisements in professional publications/career job sites may be helpful, many of the best candidates must be sought out and their interest encouraged. Our clients have found that we are able to:

- Develop the appropriate specifications for a position.
- Encourage the interest of top-level people who might be reluctant to respond to advertisements.
- Identify and recruit highly qualified individuals with an emphasis on candidates from diverse backgrounds.
- Independently and objectively assess the qualifications and suitability of candidates for positions for which we are recruiting.
- Assemble a highly skilled team of recruiters with specific expertise in the industry we are recruiting candidates while using our national network of contacts and relationships to benefit the clients we serve.

8939 S. Sepulveda Blvd., Suite 110-216, Los Angeles, CA 90045, 310-348-8800  
11040 Bollinger Canyon Road, Suite E-216, San Ramon, CA 94582, 213-308-0945

*Executive Search Consultants*  
*Connecting Leaders; Affecting Change*

## **DIVERSITY RECRUITING**

As a certified Minority Business Enterprise (MBE), *The Hawkins Company* takes pride in its record of promoting diversity and inclusion. The firm was listed in *The Wall Street Journal* as one of twenty search firms nationally that focus on cultural diversity recruiting as a best practice in the 90's. Members of the firm are often quoted by major publications regarding diversity-recruiting practices. Over seventy-five percent (75%) of the firm's placements during the past three years have been people of color and women. *The Hawkins Company's* recruitment team and national contacts allow for the successful identification and recruitment of highly qualified people of color and female candidates. In addition, sixty percent (60%) of the recruitments are nationwide in scope. Furthermore, our firm has a ninety-five percent (95%) placement rate.

*The Hawkins Company operates under Equal Opportunity Employment, Americans With Disabilities, and Affirmative Action guidelines in conducting executive search assignments and in contracting.*

8939 S. Sepulveda Blvd., Suite 110-216, Los Angeles, CA 90045, 310-348-8800  
11040 Bollinger Canyon Road, Suite E-216, San Ramon, CA 94582, 213-308-0945

*Executive Search Consultants*  
*Connecting Leaders; Affecting Change*

## **REPRESENTATIVE SEARCH ASSIGNMENTS**

*The Hawkins Company* is very pleased with its track record of successfully assisting public agencies recruit top-level senior executives. Below is a partial list of city manager and assistant city manager searches our staff has conducted:

<b><u>CLIENT</u></b>	<b><u>SEARCH</u></b>
City of Berkeley, CA	-Deputy City Manager (2018) -Deputy City Manager (2017)
City of Carson, CA	-City Manager
City of Fillmore, CA	-City of Fillmore
City of Inglewood, CA	-City Manager
City of Long Beach, CA	- City Manager (2020_
City of Oakland, CA	-Assistant City Administrator (2019) -Assistant City Administrator (2018) -City Manager
City of Richmond, CA	-City Manager
City of Richmond, VA	-Chief Administrative Officer (CAO) -Deputy CAO -Deputy CAO
City of San Bruno, CA	-Assistant City Manager (2020)
City of Santa Monica, CA	-Assistant City Manager (COO) -Deputy City Manager (2018)

8939 S. Sepulveda Blvd., Suite 110-216, Los Angeles, CA 90045, 310-348-8800  
11040 Bollinger Canyon Road, Suite E-216, San Ramon, CA 94582, 213-308-0945

*Executive Search Consultants*  
*Connecting Leaders; Affecting Change*

**PUBLIC SECTOR CLIENTS: (PARTIAL LISTING OF PUBLIC SECTOR CLIENTS)**

City of Austin, TX	City of San Antonio, TX
City of Baltimore	City of Berkeley
City of Citrus Heights	City of Dallas, TX
City of Benicia	City of Inglewood
City of Bellevue, WA	City of Long Beach
City of Carson	City of Lynwood
City of Compton	City of Oceanside
City of Kansas City, MO	City of Richmond, CA
City of Los Angeles	City of Sacramento
City of Oakland	City and County of San Francisco
City of Pasadena	City of Seattle
City of Richmond, VA	City of Santa Monica, CA
City of San Diego	County of Contra Costa
City of San Jose	County of San Diego
City of Salinas	King County, WA
County of Alameda	Dallas Area Rapid Transit District Authority
County of Los Angeles	Las Vegas Housing Authority
Atlanta-Fulton County	Long Beach Water Department
Brooklyn Public Library	Metropolitan Water District of Southern
California East Bay Municipal Utility District	City of College Park, GA
Las Vegas Valley Water District	LA County Transportation
Commission Village of Oak Park, IL	

8939 S. Sepulveda Blvd., Suite 110-216, Los Angeles, CA 90045, 310-348-8800  
11040 Bollinger Canyon Road, Suite E-216, San Ramon, CA 94582, 213-308-0945

*Executive Search Consultants*  
*Connecting Leaders; Affecting Change*

## **PROJECT MANAGEMENT AND STAFFING**

Our team consists of William (Bill) Hawkins, Christine Boulware, Todd Hawkins, Yonnine Hawkins Garr, and Tisa Jones. The team has over seventy-five (75) years of experience in researching and conducting executive recruitments. We have handled assignments from routine to highly confidential and complex recruitments in both the private and public sectors, with a consistent commitment to service, professionalism, and positive results. Bill Hawkins will serve as Project Manager and will employ other members of our team as needed.

### ***William D. Hawkins***

Mr. Hawkins is President/CEO and Founder of [The Hawkins Company](#) and has over thirty (30) years of executive search experience. During his search career, Bill has conducted and/or participated in over 1,200 executive searches. In addition to his extensive executive search experience, he is an industry pioneer in diversity recruiting at senior corporate and government levels. Since launching [The Hawkins Company](#) in 1984, the firm has conducted over 800 searches for Fortune 500 Companies, government agencies, non-profit organizations, educational institutions, and emerging businesses. Prior to establishing [The Hawkins Company](#), Mr. Hawkins spent nine (9) years as a senior member of the world's largest executive search firm, Korn Ferry International. Mr. Hawkins also served as Senior Vice President of the National Economic Management Association, an economic development firm. Other experience includes banking and government service.

Mr. Hawkins is a graduate of Howard University and has lectured extensively on recruiting and human resources issues. He holds membership in numerous business and professional organizations.

### ***Christine Boulware***

Chris Boulware serves as a Senior Consultant with [The Hawkins Company](#) and has over 20 years of experience in executive search and 6 years of senior level financial management experience in state government. She has recruited for newly elected mayors, governors and staffed cabinet level offices for the White House. Her areas of expertise include advocacy groups, education, health organizations, human services, transportation and governmental and quasi-governmental leadership roles. Ms. Boulware also has extensive experience in the areas of public policy, human resources, banking, economic development, engineering, administration, and operations. She also possesses extensive experience recruiting executive talent for large foundations and nonprofits committed to social justice causes including educational equity, criminal justice reform, housing, and health disparities.

8939 S. Sepulveda Blvd., Suite 110-216, Los Angeles, CA 90045, 310-348-8800  
11040 Bollinger Canyon Road, Suite E-216, San Ramon, CA 94582, 213-308-0945

*Executive Search Consultants*  
*Connecting Leaders; Affecting Change*

Before becoming a professional executive recruiter, Ms. Boulware served for five years in key fiscal and managerial roles with the Commonwealth of Massachusetts. She served as a Senior Budget Analyst with the Massachusetts Bureau of Fiscal Affairs and, subsequently, as Co-Budget Director for the Massachusetts Department of Social Services. In this latter capacity, she was responsible for the administration of a \$226 million budget for the Department of Social Services. She also staffed the budget office of this newly created Department and developed policies consistent with the gubernatorial agendas and state administrative policy. In 1992, Ms. Boulware served as an active member of President Clinton's first-term transition search team. She has a bachelor's degree in Political Economy from Sweet Briar College in Virginia.

### ***Yonnine Hawkins Garr***

Yonnine Hawkins Garr has been affiliated with [The Hawkins Company](#) since 2013. Ms. Garr's executive search work focuses on human resources, financial services, economic development, construction, facility management, and asset management. She also has conducted recruitments for government agencies (city management, public safety, DEI, and transportation) and nonprofits. She recently co-led the City Manager search for the City of Long Beach and will co-lead the upcoming search for the Chief Operating Officer (city administrator) search for the City of San Diego.

Her background also includes work in real estate development, construction, and real estate asset management. She is a skilled real estate commercial and residential lender, having worked as a bank loan officer. Ms. Garr has also worked in finance for a community development corporation (CDC), Ms. Garr was also a partner in a real estate investment company. She began her career in the mortgage banking and finance industry.

Yonnine is a graduate of the University of California, Irvine (BA), and attended the University of Santa Clara School of Law for one year.

### ***Todd Hawkins***

Todd Hawkins has been with [The Hawkins Company](#) since 2018. Mr. Hawkins serves in two roles at the firm. He concentrates on creating new business development opportunities and he conducts executive searches that focus on community-based nonprofits, corporate development positions and newly formed entrepreneurial enterprises at the C-suite level. He has served on several boards in Southern and Northern California. In his board roles he has chaired and served on several search committees for educational nonprofits. He has spoken nationally on issues related to diversity, equity, and inclusion.

Todd has been an integral part, as a committee chair and search committee member, on board search committees for arts, museums, and educational organizations. He has developed specialized expertise in recruiting fund development executives. In addition to his executive search experience, Todd performs community engagement, brand

8939 S. Sepulveda Blvd., Suite 110-216, Los Angeles, CA 90045, 310-348-8800  
11040 Bollinger Canyon Road, Suite E-216, San Ramon, CA 94582, 213-308-0945

*Executive Search Consultants*  
*Connecting Leaders; Affecting Change*

management, and event management for corporate, government and nonprofit organizations. He is a graduate of the University of California, Los Angeles (UCLA).

***Tisa Jones***

Tisa Jones is a senior executive search consultant and serves as *The Hawkins Company's* Candidate Engagement and Assessment Manager. She conducts both public sector and nonprofit searches and manages the firm's candidate background and reference process.

Tisa joined *The Hawkins Company* in 2016. Her recruiting and research experience covers human resources, legal, finance, IT and general management. Ms. Jones has played major roles on numerous successful executive search assignments and recently co-led the Chief Race and Equity Officer search for the City of San Diego.

Prior to joining *The Hawkins Company* Tisa managed her family's restaurant business and oversaw human resources, customer service, public relations, and finance, amongst other responsibilities.

Tisa Jones graduated from UC Berkeley with a Bachelor of Arts degree in Interdisciplinary Studies with an emphasis in Mass Communication, Psychology, and Chicano Studies. She is passionate about education and assisting people suffering from homelessness. She served on the Downtown's Women Center's inaugural junior Board from 2016-2018.

8939 S. Sepulveda Blvd., Suite 110-216, Los Angeles, CA 90045, 310-348-8800  
11040 Bollinger Canyon Road, Suite E-216, San Ramon, CA 94582, 213-308-0945

*Executive Search Consultants*  
*Connecting Leaders; Affecting Change*



## **THE SEARCH PROCESS**

Our assignments follow our well-defined six-step process:

### **1. DEVELOP A THOROUGH UNDERSTANDING AND ASSESSMENT OF THE CLIENT**

This involves meeting with the City Council, and other key stakeholders to ascertain the mission, culture, and goals of the City of Menlo Park. During this phase, a review of organizational structures, backgrounds of executives, official and unofficial lines of authority and responsibility, are conducted. The organization's plans and programs, perceived strengths and weaknesses, and the political climate are discussed. The status of potential internal candidates will also be reviewed. Perceptions about the organization's stature and attractiveness to potential candidates are crucial to developing a good organizational profile. Advantages and negative factors regarding the organization, which may aid or hinder recruitment, will be thoroughly assessed. This initial phase becomes the foundation for developing a strong partnership and effective working relationship between the client organization and *The Hawkins Company*.

### **2. DEVELOP A COMPREHENSIVE UNDERSTANDING OF THE POSITION**

In discussions with key executives, personal and professional attributes for the position are established. A recruitment profile is developed that includes a clear description of the recruitment criteria, which will serve as a profile for the ideal candidate. This profile is prepared by *The Hawkins Company*, from information provided by officials who have key relationships with the position to be filled. It is imperative that this position profile consists of realistic requirements and experience levels because it is the standard against which potential candidates are recruited and evaluated.

### **3. DEVELOP SEARCH STRATEGY AIMED AT ATTRACTING THE MOST QUALIFIED CANDIDATES**

During this phase, the objective is to accumulate a strong pool of candidates. We will work with the to identify appropriate candidates. Organizations are targeted as sources of candidates and geographical preferences are established. We will also finalize recruitment plans and timelines.

*The Hawkins Company* will use various candidate solicitation methods, including direct sourcing based upon industry research, our candidate data bank, and contacts with appropriate professional associations. Since individuals with the desired qualities are not usually actively looking to make a change, they must be recruited. An effective strategy is crucial to a successful recruitment, and *The Hawkins Company* works closely with the client in developing the search strategy.

8939 S. Sepulveda Blvd., Suite 110-216, Los Angeles, CA 90045, 310-348-8800  
11040 Bollinger Canyon Road, Suite E-216, San Ramon, CA 94582, 213-308-0945

*Executive Search Consultants*  
*Connecting Leaders; Affecting Change*

#### **4. EVALUATE POTENTIAL CANDIDATES**

In addition to the formal advertising and mailings, *The Hawkins Company* uses a private sector- direct sourcing approach in locating candidates who meet the position specifications and have established patterns of accomplishments and success. Potential candidates and sources of candidates, identified through the above method, are actively recruited to become candidates, and/or solicited as referral sources. We will review and acknowledge in writing all resumes received. Once the candidate pool is established, all qualified candidates, both internal and external, will be evaluated against the core competencies established for the position. Reports are prepared and reviewed with the client to select the most appropriate candidates for further consideration. These candidates are interviewed, by *The Hawkins Company*, in two phases. The first phase involves a telephone interview. Based upon information obtained in this interview, a decision is made as to the most appropriate candidates for further consideration. These candidates will then be interviewed in person or by a video conference by *The Hawkins Company*.

Our goal is to formulate a comprehensive understanding of their background, i.e., qualifications, pertinent accomplishments, experience, ability to meet special needs of the position and their interest in being considered. Additionally, candidates are evaluated to determine their overall suitability as a member of the client's management team, as well as their strengths and limitations. It is our policy to conduct reference checks, to include job performance, qualifications, and personal history, and ascertain degree verification on all finalists, i.e., professional, educational, and other credentials. We also conduct other background investigations, i.e., criminal record, and investigate other pertinent factors as required for the recruitment.

The most qualified candidates are selected for presentation to the Council. We will prepare a recruitment report which will detail each candidate's background, experience, education, and accomplishments. Reference summaries and *The Hawkins Company's* professional appraisals are also provided on the final candidates.

#### **5. PRESENTATION OF FINAL CANDIDATES**

*The Hawkins Company* works closely with the client and final candidates to arrange personal interviews. If requested, suggested interview questions and rating forms are provided. Additional selection processes such as assessment centers, psychological evaluations, and interview boards are available options. While the hiring decision is always the client's, we are prepared to assist with negotiations relative to terms and conditions of employment. We maintain a very close relationship with both candidate and client during the offer/acceptance period.

8939 S. Sepulveda Blvd., Suite 110-216, Los Angeles, CA 90045, 310-348-8800  
11040 Bollinger Canyon Road, Suite E-216, San Ramon, CA 94582, 213-308-0945

*Executive Search Consultants*  
*Connecting Leaders; Affecting Change*

## **6. CANDIDATE AND CLIENT FOLLOW-UP**

After the executive is hired, *The Hawkins Company* meets with the client to evaluate the overall executive recruiting strategy. Our strengths and the level of client satisfaction are assessed, along with those areas needing improvement.

We periodically follow-up with the hired executive to identify any areas of concern and to ensure a lasting relationship

*Throughout the search process, The Hawkins Company maintains a close Client-Consultant working relationship which includes periodic status reports.*

## **PROJECT MANAGEMENT APPROACH**

The key elements of *The Hawkins Company's* approach to effective project management are developed in the work plan. They include:

- Mutually agreed upon performance targets based on sound partnering principles.
- Realistic time schedule to complete tasks.
- Periodic progress reporting (bi-weekly).
- Immediate client notification of any issues/challenges that are impacting the recruitment.
- Open and honest dialogue between consultant and client at all stages of the search.
- Assigning, managing and coaching staff involved in recruiting activities.
- Internal status discussions regarding the recruitment.
- Documented follow-up between consultant and client at all stages of the recruitment.

All search assignments are tailored to meet the specific client needs and requirements. While, we encourage our clients to follow certain best practices within the recruiting profession, we accept and follow the client organization's practices that are part of their standard operating procedures.

The biggest challenge, we encounter in most recruitments, is establishing the "fit" which is a combination of professional and personal attributes; beliefs and values; and the "win win." The project manager's role is to confirm realistic core competencies for the position to be filled with the client. These competencies need to be ranked or prioritized. The competencies become the standard for identifying, recruiting, evaluating, assessing candidates and managing the assignment. Additionally, the core competencies become the primary quality control mechanism and should form the basis for the hiring decision.

8939 S. Sepulveda Blvd., Suite 110-216, Los Angeles, CA 90045, 310-348-8800  
11040 Bollinger Canyon Road, Suite E-216, San Ramon, CA 94582, 213-308-0945

*Executive Search Consultants*  
*Connecting Leaders; Affecting Change*

The core competencies are used to rate the candidates' material and determine which individuals will receive additional consideration. Using core competencies, both personal and professional, will reduce the tendency to make subjective hiring decisions and therefore enhance the client's ability to make successful hiring decisions. For a good hire to occur, both the needs of the client and the candidate must be met.

The other area where strong project management can prove beneficial is how you approach the recruitment process. *The Hawkins Company* employs a variety of methods to recruit highly desirable candidates who may not currently be in the job market. They include:

- Personal meetings with a potential candidate to discuss the specifics of the job and address any obstacles.
- Getting other influential members of the profession to encourage reluctant candidates to consider the opportunity. **Peer to peer recruiting is a powerful tool.**
- Having a client representative contact the potential candidate and encourage them to become a candidate has been very helpful. **People enjoy being sought after.**

Being able to assess a candidate is as important as recruiting top level individuals. We use a three-step approach to candidate assessments.

1. Thorough personal interviews to assess skills in relationship to required competencies.
2. Research of literature, public records, news accounts and other sources to ascertain career accomplishments/awards or controversies/problems that will impact the candidate's performance.
3. The 360-degree reference/background investigation includes not only people supplied by candidates, but individuals identified, by the consultant, who are in positions to give candid non-bias impressions. Talking to people who have supervised the candidate, worked with them as peers, and who have served as subordinates gives us the 360-degree perspective that is useful in developing a complete candidate assessment.

The final part of our project management approach includes developing a schedule for formal progress meetings, informal status updates, and mutual feedback regarding the recruitment. Our formal meetings are scheduled as follows:

1. Beginning of the recruitment to develop the work plan.
2. Presentation of the initial recruitment report.
3. Report on the final candidates.

8939 S. Sepulveda Blvd., Suite 110-216, Los Angeles, CA 90045, 310-348-8800  
11040 Bollinger Canyon Road, Suite E-216, San Ramon, CA 94582, 213-308-0945

*Executive Search Consultants*  
*Connecting Leaders; Affecting Change*

We are always available for additional meetings as needed by the client or consultant. During both formal and informal meetings, we address issues and activities that may require changing the scope or adjusting core competencies. Minor changes are immediately incorporated into the work plan, while major shifts/changes will require consultation between the project manager and the client.

8939 S. Sepulveda Blvd., Suite 110-216, Los Angeles, CA 90045, 310-348-8800  
11040 Bollinger Canyon Road, Suite E-216, San Ramon, CA 94582, 213-308-0945

*Executive Search Consultants*  
*Connecting Leaders; Affecting Change*

## **CITY MANAGER** **EXECUTIVE SEARCH** **TIMELINE**

### *Overview of Proposed Tasks and Timeline*

	<b>Proposed Tasks</b>	<b>Proposed Timeline</b>
1.	Initial meetings with the City Council collectively and individually to identify core competencies and recruitment parameters for the position. Identify key information for the profile.	<b>Week 1-2</b>
2.	Interview other key stakeholders as identified by client. Prepare community survey for community input. Post survey.	<b>Week 2-3</b>
3.	Present work plan including detailed timeline and survey results. Finalize recruitment profile/brochure and place advertisements.	<b>Week 3-4</b>
4.	Candidate research and recruitment by search consultants. (usually 6 weeks)	<b>Week 5-10</b>
5.	Prepare and submit initial recruitment report to client. Meet with client to select top 6-8 candidates for evaluations.	<b>Week 12</b>
6.	Candidate (6-8 shortlisted) screening and evaluations by search consultants including preliminary referencing.	<b>Week 13-14</b>
7.	Presentation of report on shortlisted candidates. Council selects candidates for site interviews.	<b>Week 15</b>
8.	Top candidates participate in interview process. Final candidate selected for additional evaluations by the Council.	<b>Week 16</b>
9.	The City Council selects and makes job offer to the chosen candidate.	<b>Week 17-18</b>

***Adjustments May Be Made To This Timeline As Needed***

8939 S. Sepulveda Blvd., Suite 110-216, Los Angeles, CA 90045, 310-348-8800  
11040 Bollinger Canyon Road, Suite E-216, San Ramon, CA 94582, 213-308-0945

*Executive Search Consultants*  
*Connecting Leaders; Affecting Change*

## PROJECT COST

The professional fee for conducting the **City Manager** recruitment is \$32,000 and includes a community survey. The expenses for this recruitment include approved consultant/candidate travel/lodging, research and brochure development, report preparation, postage/mailings, and advertisements, and will not exceed \$7,500. The cost of the fixed price contract is **\$39,500**.

<u>Professional Fee and Estimated Expenses</u>	
<i>Item</i>	<i>Cost:</i>
Professional Fee	\$32,000
<b><i>Reimbursable Expenses (estimated):</i></b>	
Advertisement	\$ 1,500
Brochure Development/Printing/Mailing	1,500
Background Checks/Research	750
Report Preparation	750
Consultant & Candidate Travel	3,000
<i>Subtotal-Expenses (Not to Exceed)</i>	<u>\$ 7,500</u>
<b><i>Total</i></b>	<b><u>\$39,500</u></b>

It is our policy and practice to submit monthly invoices for professional fees and expenses. We bill our professional fee in three (3) equal installments. The initial fee of \$10,666 will be rendered upon signing a letter agreement/contract. The second installment of 10,666 is rendered after the delivery of our recruitment report. The final installment will be billed once the final candidates are interviewed. Consultant's fees **are not contingent** upon hiring a City Manager candidate, and Consultants shall continue to recruit and present candidates until a suitable individual is selected and hired by the city. The billings will include reimbursable expenses on the assignment, as incurred. Authorized candidate travel is included in the expenses.

We will offer the city six months of executive coaching for the new city manager at a flat fee of \$6,000. The cost for other requested services will be billed at the rate of \$250 per hour. A community survey is part of the search services provided at no additional cost to the city.

## PROJECT GUARANTEE

Should the employee leave voluntarily or be discharged for cause within a one-year period, we will conduct the search again for expenses only. Additionally, should your organization hire additional candidates referred by *The Hawkins Company* in conjunction with this assignment, a fee of \$25,000 per candidate will be charged.

8939 S. Sepulveda Blvd., Suite 110-216, Los Angeles, CA 90045, 310-348-8800  
11040 Bollinger Canyon Road, Suite E-216, San Ramon, CA 94582, 213-308-0945

*Executive Search Consultants*  
*Connecting Leaders; Affecting Change*

## CLIENT REFERENCES

<b>REFERENCE #1</b>	
Company Name	City of Long Beach
Contact Person	Vice Mayor Rex Richardson
Phone Number	(562) 570-6137 work; (310) 766-3433 cell
Email	<a href="mailto:Rex.Richardson@longbeach.gov">Rex.Richardson@longbeach.gov</a>
Recruitment	City Manager 2020

<b>REFERENCE #2</b>	
Company Name	East Bay Regional Park District
Contact Person	Sabrina Landreth, General Manager former City Administrator, (client) City of Oakland, CA
Phone Number	(510) 544-2000
Email	<a href="mailto:slandreth@ebparks.org">slandreth@ebparks.org</a> ; <a href="mailto:sabaum_001@yahoo.com">sabaum_001@yahoo.com</a>
Recruitments	Retained by the City Administrator to conduct multiple executive leadership positions for her executive team during her tenure (2015-2020) and we have continued our work with the City. Searches included two (2) Assistant City Administrators, Director of Parks & Recreation, Director of Race & Equity, Chief of Violence Prevention, Director of Housing & Community Development.

<b>REFERENCE #3</b>	
Company Name	City of San Bruno
Contact Person	Jovan Grogan, City Manager. former Deputy City Manager, City of Berkeley (both client San Bruno & placement Berkeley)
Phone Number	510-529-5595
Email	<a href="mailto:jgrogan@sanbruno.ca.gov">jgrogan@sanbruno.ca.gov</a>
Recruitment	Assistant City Manager (2020), Fire Chief, Dir. of Parks & Recreation

8939 S. Sepulveda Blvd., Suite 110-216, Los Angeles, CA 90045, 310-348-8800  
11040 Bollinger Canyon Road, Suite E-216, San Ramon, CA 94582, 213-308-0945

*Executive Search Consultants  
Connecting Leaders; Affecting Change*



8939 S. Sepulveda Blvd., Suite 110-216, Los Angeles, CA 90045, 310-348-8800  
11040 Bollinger Canyon Road, Suite E-216, San Ramon, CA 94582, 213-308-0945

*Executive Search Consultants*  
*Connecting Leaders; Affecting Change*



August 5, 2021

Jen Wolosin, Councilmember  
City of Menlo Park  
701 Laurel Street  
Menlo Park, CA 94025

Dear Ms. Wolosin:

Thank you for the opportunity to submit our recruitment proposal for the position of City Manager for the City of Menlo Park. We take great pride in providing our clients exceptional service and excellent results. These successful client partnerships result from an active and comprehensive level of Principal involvement leading to positive business relationships and highly satisfied clients.

We have extensive city management recruitment experience throughout California and feel well suited to meet your city's needs on this search. Currently, we are conducting City Manager recruitments for the cities of Malibu, Cupertino, Yreka, Ross, Tulare and Paso Robles, and recently completed City Manager searches for the cities of Sausalito, Fowler and Foster City. Additionally, in the past 18 months we've completed City Manager searches for the cities of Stockton, Simi Valley, Hawthorne, Whittier, Port Hueneme, Pinole, Tulare and Sand City. Overall, during the past four years our firm has completed 29 city manager assignments including recruitments for the cities of Anaheim, Fremont, Vallejo, Hermosa Beach, Martinez, Half Moon Bay, Visalia, Fullerton, Redding, South El Monte, Monte Sereno, Benicia and Beaumont. We feel the contacts made from these assignments would be highly beneficial to this search and your overall recruitment needs.

Our extensive database of executives in municipal and county government provides an excellent foundation for the outreach efforts we describe in our proposal. We've also had extensive interaction with City Councils, City Managers and Assistant City Managers based on our labor relations practice. All of these contacts would be an excellent resource in support of this recruitment.

Following review of our proposal, it is our hope that our history of successful recruitments, our professionalism and positive results we have delivered for our clients will provide the basis for selection of our firm. This proposal of recruitment services contains the following information:

- Company Overview
- Firm Qualifications/Experience
- Recruitment Team

William Avery & Associates, Inc.  
Consultants to Management

3-1/2 N. Santa Cruz Ave., Suite A  
Los Gatos, CA 95030  
408.399.4424  
Fax: 408.399.4423  
www.averyassoc.net

- Recruitment Approach/Methodology
- References
- Consulting Fee
- Timeline
- Guarantees & Ethics
- Principal Profiles
- Sample Materials

Thank you for the opportunity to be considered for this recruitment. If you have any questions, please do not hesitate to call me at 408.399.4424 or 408.472.7873 (cell).

Sincerely,



William H. Avery

WHA:jmc



## PROPOSAL FOR THE CITY OF MENLO PARK RECRUITMENT FOR CITY MANAGER

### William Avery & Associates, Inc. – Overview

William Avery & Associates, Inc. (Avery Associates) is a successful and service focused Management Consulting firm based in Los Gatos, California. Incorporated in 1982, the firm specializes in Executive Search, Labor Relations and Human Resources/Management Consulting.

The firm currently includes two Principals and several key consultants. Bill Avery, the founder of Avery Associates, heads and manages the firm. He oversees the Labor Relations practice and is heavily involved in the search business including leading key searches. Paul Kimura focuses on and manages the Executive Search and Recruitment practice. Key staff members include Bill Lopez, Kristi Ward and Sam Avery, who support the search practice and the firm's administrative staff includes Tomi Ewing, Jackie Collins and Michelle Ross. Temporary staff as needed augments the team.

Mr. Avery, having served in the past as a City Manager, provides the firm with direct experience and knowledge of city administration. Mr. Kimura's expertise in executive, technical and business recruitment, which he gained during his nineteen years of high technology experience, provides the basis for many of the recruitment strategies and tactics utilized by the firm. (Their profiles are attached.) Collectively and combined, the firms Principals offer exceptional expertise in the area of public sector recruitment and consulting.

Below is the location and phone numbers of the office which will coordinate this activity along with the contacts and authorized representatives of Avery Associates:

Bill Avery  
3 ½ N. Santa Cruz Ave. #A  
Los Gatos, CA 95030  
(office) 408 399-4424  
(cell) 408 472-7873  
(email) [bill@averyassoc.net](mailto:bill@averyassoc.net)

Paul Kimura, Principal  
3 ½ N. Santa Cruz Ave. #A  
Los Gatos, CA 95030  
(office) 408 399-4424  
(cell) 408 472-7936  
(email) [paulk@averyassoc.net](mailto:paulk@averyassoc.net)

### Firm Qualifications/Experience – What Differentiates Avery Associates

Exceptional service delivery and a very high-quality work product provide excellent results for our clients. This begins with the initial client meetings, which lead to detailed timelines for deliverables followed by weekly recruitment status updates following initiation of the search. Our candidate outreach efforts are professionally and confidentially conducted. The evaluation materials we provide clients are routinely characterized as accurate, comprehensive and of very high quality. We believe more so than any other public sector recruitment firm. This is largely based on our interview system utilizing behavioral interview techniques, which we describe in our recruitment plan. This leads to a quality product with excellent end results for our clients.



The service element is based on two factors: The first is the collective service philosophy from all of our organizational team members. They are each dedicated to providing service and support to clients. The second factor is based on the high level of engagement and participation from the firm Principals in every search assignment. This hands-on involvement includes client interface, identifying and developing the ideal candidate profile and position specification, development of the search strategy, candidate outreach, interviewing and assessment, completion of reference interviews, candidate presentation, final interview facilitation and when desired, negotiation of employment terms with the successful candidate.

#### Recruitment Team for the City of Menlo Park

Bill Avery will serve as the Project Lead for this assignment and will be assisted by Bill Lopez and Sam Avery. Mr. Avery will be personally involved in the initial client meetings, development of the ideal candidate profile and search strategy, interviewing and assessment of candidates, the presentation of candidates, attendance at final interviews and will be available throughout the search process to provide other related consulting services.

#### Recruitment Approach/Methodology

##### I. Position Profile and Organizational Assessment

The initial assessment phase is a critical component of the search process. Mr. Avery will individually meet with City Council members, and with other city staff (as deemed appropriate by the policy makers) to discuss the organizational needs and position requirements and to formalize the job description.

We understand that some communities are committed to engaging their residents in determining the ideal profile for the new City Manager. If this is a priority for the City, we can utilize various approaches in reaching out to the community in soliciting their insights/inputs regarding the ideal City Manager. The ideal approach towards reaching the greatest number of residents is through an online community survey linked through your city's website. Alternative options include: A town hall meeting (in today's environment, this would be conducted via video conferencing); conducting a "targeted" outreach effort to key community members as identified by the City Council (i.e., Service club/Chamber of Commerce/Downtown Association leaders; educational executives; homeowners association leaders; executives of community-based organizations). Any or all of these community outreach efforts can be incorporated into our recruitment model. We would include the Council's preferred approach as part of our Scope of Services at no additional charge.

Our goals in securing the collective insights from our meetings are to:

- Understand the City priorities for this position.
- Develop a clear understanding and consensus on the expertise, experience, education, performance attributes and operational style of the ideal candidate.



- Discuss the goals, objectives, deliverables, and challenges related to this position.
- Gain insight of the various organizational dynamics and departmental issues that exist within the organization.
- Identify the compelling aspects to this opportunity.

The formal recruitment announcement that includes the ideal candidate profile would be developed from the above discussions and incorporated into the formal position announcement. The candidate profile is also utilized in various other means as a marketing tool, for advertising copy, postings, and for other announcements.

## II. Development of the Search Strategy

Our search strategy will be developed in conjunction with the organizational assessment. The final approach is based on your input and considerations during the assessment activity. We would incorporate the following elements into this search:

- Original research, which consists of identification and contact of current incumbents or other candidates who meet the profile but are not actively seeking other employment.
- Development of a targeted candidate list based on our extensive database of key executive contacts, referrals and recommendations from key sources, and other current and former City Management personnel who have extensive contacts and networks in this area. We also make extensive use of Linked-In Recruiter and email/phone contact in our proactive outreach efforts to solicit interest from potential candidates.
- Public information sources that include various membership listings such as the League of California Cities, ICMA and the various municipal organizations within the U.S.
- An extensive mailing campaign to current city managers and select assistant managers throughout the U.S.
- Print advertising in ICMA Newsletter, Jobs Available and any other print publications deemed appropriate by the City.
- Internet job postings on national public sector employment bulletin boards, City Management and Municipal association-based web sites, and our company website.

## III. Candidate Assessment

Our assessment process involves several “tiers” of evaluation. All candidates responding to this position will initially be evaluated based on their resume and if appropriate, an extensive phone “screening” by a member of the project team. Candidates who pass the initial



“qualifying” criteria are then scheduled for a formal interview with Mr. Avery. These extended personal interviews typically take one hour and a thorough discussion of their experience, accomplishments, management philosophy and interpersonal style takes place.

In interviewing candidates, we utilize a methodology based on “behavioral” interview techniques. Fundamentally, this approach explores a candidate’s past accomplishments and experiences that relate to the position being considered. The philosophy here is that the best indicator of future performance is to evaluate past behavior. This methodology allows the firm to “project” how a candidate would approach and address the key challenges in the new position.

Those individuals who best fit the position requirements will have a Candidate Assessment Report developed by the Principal who conducted the interview. Additionally, two initial reference interviews are performed on these candidates. The reference interviews provide our clients with additional insights on the candidate’s “behavior” and style.

#### IV. Candidate Presentation

Based on a predetermined date to meet and present candidate recommendations to the City Council, Mr. Avery will provide an overview of the recruitment and present our recommendations. We feel our extensive qualification, interview, and reference interviewing process and the knowledge gained during our initial assessment period; enable our client to proceed with fewer rather than more finalists. However, we will not restrict or limit the number of candidates recommended as this decision is related to the overall strength and depth of the candidate pool.

The final candidates are presented in our extensive candidate presentation “book”. Each finalist will have a file consisting of a candidate summary sheet, the submitted cover letter and resume, the Candidate Assessment Report (based on the “behavioral” interview), and two candidate reference interviews. This extensive profile on each recommended candidate continually generates positive feedback from our clients as it provides extensive detail beyond just a resume.

The Candidate book also identifies other candidates who were given secondary consideration, which provides the client insight on others who were interviewed. Candidate summary sheets are created for everyone who submitted a resume would also be included. This provides the client an insight to the level and nature of response for their position.

#### V. Selection Process

At the conclusion of the candidate presentation, it is anticipated the final candidate interview group will be determined by the Council. At that time, Mr. Avery will also help finalize the Council’s desired interview process. Thereafter, we will coordinate the final interview logistics with city staff.



Our firm will develop interview schedules, notify candidates of status and provide travel guidance if required, related to the interview process. We will also develop potential interview questions and be in attendance during final interviews to help facilitate the process and to lead an end of day debrief and evaluation process. The City will provide the facility. Based on the desired consideration process, our firm will coordinate all necessary logistics with city staff for each phase of the process.

VI. Position Closure and Follow-Up

Based on the firm’s experience in human resource management and executive search, we are able to assist our clients in formulating appropriate compensation and other employment arrangements. We will be available throughout our retention to assist in this process.

As a matter of policy, Avery Associates monitors the transition and progress of any executive we place with a client. Within the first three to six months following the hired individual joining the City, we will speak with that individual to ensure the transition has effectively occurred. During the same period, we will also review the individual’s status with your office.

Recruitment Timeline

We have the capacity to be available within a one-to-two week window to initiate new recruitments.

Task	Scheduled Dates
<i>Search Initiation, Marketing &amp; Advertising Development:</i> <ul style="list-style-type: none"> <li>▪ <i>Initial meetings with city manager and city staff to define the ideal candidate profile</i></li> <li>▪ <i>Develop draft of recruitment brochure for approval by client</i></li> <li>▪ <i>Recruitment strategy finalized</i></li> <li>▪ <i>Determination of advertising scope and placement deadlines</i></li> <li>▪ <i>Brochure designed and printed</i></li> </ul>	<i>Weeks 1 - 4</i>
<i>Marketing, Advertisement and Outreach Period:</i> <i>Advertise in:</i> <ul style="list-style-type: none"> <li>▪ <i>Mailing of brochures</i></li> <li>▪ <i>Jobs Available</i></li> <li>▪ <i>ICMA newsletter and website</i></li> </ul> <i>Preliminary candidate screening</i>	<i>Weeks 4 - 10</i>
<i>Candidate Review - Screening and Finalists Selection</i>	<i>Weeks 9-12</i>
<i>Development and finalization of Interview process and interview questions</i>	<i>Weeks 13-14</i>
<i>Interviews with City</i>	<i>Week 15</i>
<i>Final interviews and reference checks</i>	<i>Week 16</i>
<i>Appointment Offer/Acceptance</i>	<i>Week &gt;17</i>
<i>Report to Work Date</i>	<i>Week &gt;17</i>





## Client References

- I. City of Anaheim  
Chris Zapata, Former City Manager; 619.240.5620 (C); email: chriszapata007@gmail.com  
Tom Tait, Former Mayor; 714.403.1804; email: tomtait@tait.com
- II. City of Paso Robles  
Greg Carpenter, Interim City Manager; 310.261.1910 (C); email: citymanager@prcity.com  
(former City Manager in El Segundo)  
Steve Martin, Mayor; 805.674.4890 (C); email: smartin@prcity.com
- III. City of Foster City  
Peter Pirnejad, City/District Manager (placed candidate); 650.286.3220;  
email: email: ppirnejad@fostercity.org  
Jon Froomin, Council Member; 650.286.3502; email: jfroomin@fostercity.org
- IV. City of Stockton  
Michael Tubbs, Former Mayor; 209.351.2956 (C)

## Consulting Fee

Based on the services described in our proposal, the professional services consulting fee for this recruitment will be \$19,400. We would provide our first consulting invoice in the amount of \$8,400 at the outset of the search. A second invoice of \$5,500 would be billed with the presentation of candidate recommendations and the final invoice of \$5,500 for the retainer will be submitted at the completion of the search. The consulting fee will be inclusive of all services defined within this proposal unless otherwise stated.

In addition to the Professional Services Fee, normal and direct out-of-pocket expenses associated with the search are charged back to the client. Expenses for this assignment would not exceed \$6,000 without the express consent of the City. These expenses include advertising, clerical time, supplies, printing, telephone, postage, background checks and consultant travel for client discussions, meetings, local and out-of-area candidate interviews. All expense items are reimbursed "at cost" and will be detailed and billed on a monthly basis.

As requested in your RFP, below are hourly rates for any services that the City might request outside the scope of services within the proposal.

Principals	\$200.00
Senior Recruiter/Contract Recruitment Associates	\$100.00
Clerical	\$ 40.00



## Guarantees and Ethics

Whenever William Avery & Associates, Inc. is retained; we make several guarantees and commitments to a client. Due to our experience, knowledge and success within the management-consulting field, we assure a client that we will only present candidates who meet a substantial majority of the ideal qualifications that you have outlined. We are also committed to continue our search efforts until a successful candidate is employed.

During our placement efforts, we openly share any relationships, previous experience and knowledge for any candidate we present for consideration. Our commitment and responsibility are to our clients and their best interests.

It is also our practice to replace a candidate who may voluntarily resign during the first year of his/her employment. This same commitment applies if the client finds it necessary to terminate or to request the resignation of the selected individual in the first year for any reason. In either case, we invoice a client only for out-of-pocket expenses incurred in identifying a replacement.



## **Avery Profile**

### **William Avery**

William Avery founded his successful management consulting firm in 1981. He has directed William Avery & Associates in service as a Labor Relations and Executive Search consultancy, serving personally as a chief negotiator, trainer, and representative in grievance and disciplinary matters.

A specialist and widely recognized expert in employer-employee relations, he has served as a City Manager (Los Gatos) and Assistant City Manager. While City Manager, he was President of the Santa Clara County City Manager's Association and Chair of the County Employee Relations Service.

Bill has lectured at De Anza College, San Jose State University, and Stanford University, and regularly makes presentations for the League of California Cities, CALPELRA, and other public sector organizations.

Building on his personal track record of success, he expanded the firm's focus to include increased emphasis on public and private sector search. He added proven industry professionals with expertise in these areas. The result has been to create an exceptionally strong management consulting firm, now known as Avery Associates, with the expertise to provide the full range of services required for successful public or private sector executive search.

A key measure of the firm's success has been the many long-term relationships that he and his staff have established with clients.

Bill holds B.A. in Political Science and an MPA from San Jose State University, where he was graduated with highest honors.



## **Avery Profile**

### **Paul Kimura**

Paul Kimura brings a unique combination of recruitment and business experience to Avery clients.

Paul is involved in leading Avery's public sector professional searches. He has been both a corporate recruitment director and HR director for a number of high technology companies, ranging from Fortune 500 firms such as Novell and National Semiconductor to a Silicon Valley start-up. His proven recruitment and HR generalist skills help him bring forward the best available candidates and properly assess their skills and "fit" with client organizations.

Indeed, many of the recruitment strategies and tactics incorporated into the Avery search process are a direct result of Paul's extensive recruitment experience in the high technology industry.

Paul has been a successful HR consultant, guiding clients through all aspects of Human Resources functions — compensation & benefits, employee and management training, performance management, and termination issues.

He is skilled in areas such as strategic planning, executive coaching, separation negotiation, and organizational assessment and design. It's another service that Avery Associates is able to offer its clients because of the unique background of its principals — and Paul's extended skill set in Human Resources underscores the fact that Avery professionals "have been there" and understand your needs from a personal perspective.

Paul holds a B.S. degree in Business Administration from San Jose State University. He is active in professional HR organizations and in the community, where he has worked with a number of education, youth service, civic, business, and cultural organizations.

"Just as Avery looks to form long-lasting relationships with its clients, I believe in making the same commitments within my community."



## Sample Materials

We have attached several examples of our work product. Contained are a candidate assessment, a reference interview and an ad sample. Also included with our proposal are sample recruitment brochures.

### CANDIDATE ASSESSMENT FOR

---

\_\_\_\_\_ has over 20 years of professional experience including investment management, finance management, and budgets. During the past ten years, she's had two different tenures with \_\_\_\_\_, and in between served as the Treasury and Investment Director for the \_\_\_\_\_ based in \_\_\_\_\_. Her \_\_\_\_\_ experience includes serving as a portfolio manager for a global real estate fund and also for an equity portfolio. \_\_\_\_\_ educational background includes an M.B.A. and a B.S. in Business Administration, both from Cal State University in Sacramento.

\_\_\_\_\_ rejoined \_\_\_\_\_ in October of 2013, following two years in the Washington assignment. During this time she has reported to the portfolio manager of the real estate investment fund, and administers a portfolio of up to \$3.5 billion in various partnerships and funds. In her assignment with \_\_\_\_\_, she had oversight for the entire portfolio, which consisted of both defined benefit funds and corporate funds. She felt her greatest accomplishment there was in evolving the investment direction towards a focused and structured asset allocation strategy. She left the \_\_\_\_\_ assignment to return to \_\_\_\_\_ for personal and family reasons. \_\_\_\_\_ began her career at \_\_\_\_\_ in 2005 where she served as an accounting services manager with responsibility for a new investment accounting system implementation. Subsequent to that, she moved into a portfolio management position for a two-year period.

\_\_\_\_\_ offers a nice broad range of experiences, although her investment experience is limited to the asset classes for which she had oversight in her last two \_\_\_\_\_ assignments. Her knowledge of the defined pension environment is a real plus, and \_\_\_\_\_ also focused on investment and finance areas in her pursuit of her M.B.A. Her management experience at \_\_\_\_\_ is a bit limited, although she has headed up project teams and has actively worked across the organization, especially in the implementation of a new finance IT system earlier in her career. With \_\_\_\_\_, she reported to the CFO, had one direct report, and worked closely with the controller's staff. \_\_\_\_\_ especially strong in the interpersonal area, as she has a very pleasant and positive manner and seems to be quite effective in developing and maintaining strong work relationships. She's quite enthused at the prospect of taking a senior level position, and appears to have great interest in the position in \_\_\_\_\_.



## REFERENCE INTERVIEW

Candidate's Name: \_\_\_\_\_

Date:

Reference: Name  
Title  
Agency  
Phone

Position Applying For: Title  
City of \_\_\_\_\_

1. How long have you known this individual? What is the nature of your work relationship?

She moved up to \_\_\_\_\_ to work for us as our System Treasurer. She was here for about two years between 2010-2012. We are a \$1.2 billion hospital business with about \$1 billion in the retirement funds. She did a real nice job helping us reformat our Asset Allocation investment policy.

2. What has impressed you most about his/her leadership, management, and administrative style? Is he/she effective at providing direction and motivation to staff?

She is a knowledgeable person and an expert in treasury management. She would always be up front about what she knew and what she didn't. Her response to questions was always great. She would research the sticky problems and close the loop, particularly with external auditors. She had one direct report and relationships with the accounting folks and external people. She relates very well at all levels. She presented before the Board and some pretty sophisticated people.

3. Describe the candidate's strengths in the area of investing, specifically in terms of managing funds and investment portfolios.

It's not about market timing, it's about having a sound strategy and policy that has to be vetted and agreed upon. That's where she stands. She holds people accountable and tries to understand the managers' particular strategies. To her, it's getting beneath the numbers and really understanding what's going on.

4. Tell me about this individual's communication and operational style. How well do they interact with department heads, staff, City Council and external agencies?



She likes to make it fun, which is a good thing! We had a relationship with external managers where she really got to know them. You can pick up the phone anytime and ask her things. She is a very good networking person. She is really good at working with the accounting folks, also.

5. Can you tell me about his/her commitment to customer service?

She would do excellent research and provide excellent information. If you asked a question, she would do more. She got her work done on time.

6. Is there anything else you would like me to know about this person to help us evaluate him/her as a candidate for this position?

I trusted her. She was very honest. She was always good with me and would tell me what happened when it happened, as opposed to just sitting on the information. She has managed teams before. The other thing I liked about her is her sophistication that she brought from \_\_\_\_\_. She kept the relationships open with them, and they were really happy to get her back. She is capable of doing a lot more.

**CITY OF PORT HUENEME**

The City of Port Hueneme (pronounced "Wy-nee'mee") is a charming, friendly and relaxed seaside community in Ventura County, California. Visitors quickly find that the quality of life in Port Hueneme is one-of-a-kind. Those who live or work here benefit from the City's small town atmosphere, affordable housing, temperate climate, clean air, low crime, quality education and recreation. Residents consistently cite the high quality of life offered due to planned development, excellent public facilities and responsive city services as being primary reasons for choosing to live in the City.

The City Manager is appointed by the City Council and serves as the operational head of city government. In overseeing city operations, the expectation is to focus on quality of life issues that are so vital to the City Council and residents. The successful candidate will need to establish and maintain an exceptional working relationship with the Council, city staff and the community. Proactive, candid and timely communications with all Councilmembers in keeping them informed of current issues/developments and in providing effective operational alternatives and recommendations will be vital in this role. In doing so, the new Manager must create an environment of trust and credibility essential in facilitating discussion and decision making within the City.

The new City Manager will be an effective and seasoned public sector administrator who creates and maintains an environment of mutual respect and transparency. A strong background in budget, finance and administration is essential. Experience as a City Manager, Assistant/Deputy City Manager or as an Executive Director or department head of a complex public sector organization is required. A BS/BA in a related field is essential and a Master's is ideal. The salary is open and negotiable, dependent on qualifications. To be considered, please submit (email preferred) a letter of interest, resume, salary history and contact information including email addresses for five work-related references to Bill Avery by August 5, 2016. A formal job announcement is available at <http://www.averyassoc.net>.



**AVERY**  
ASSOCIATES  
William Avery & Associates  
Management Consultants  
3 1/2 N. Santa Cruz Ave., Suite A  
Los Gatos, CA 95030  
408.399.4424  
Fax: 408.399.4423  
email: [jobs@averyassoc.net](mailto:jobs@averyassoc.net)  
[www.averyassoc.net](http://www.averyassoc.net)

**CITY  
MANAGER**





# *City of Foster City*



*invites your interest  
for the position of*

## **City/District Manager**



## The Community

Based on the idea of a planned community on the San Francisco Peninsula, Foster City was incorporated in 1971. The rest is history, and the City is now home to almost 34,000 residents and a wide array of industry--including some of the bay area's elite businesses, such as VISA and Gilead Sciences. Foster City is conveniently located midway between San Francisco and San Jose on the western shoreline of the San Francisco Bay, east of U.S. 101, which provides convenient access to the San Francisco Airport and San Francisco to the north and Santa Clara County to the south. Foster City prides itself on its well-planned neighborhoods, shopping centers, and most importantly, a supreme quality of life.



## City Government

The City of Foster City and the Estero Municipal Improvement District provide governmental services to the citizens of Foster City. Foster City was incorporated on April 27, 1971, is a general law city and uses the Council-Manager form of government. The members of the City Council serve as the policy-making body for both governmental agencies. City voters elect Council members to staggered terms of four years each. A City Manager is appointed by and responsible to the City Council to serve as Chief Administrative Officer overseeing personnel, developing the budget, proposing policy objectives, and implementing policies and programs adopted by the City Council.

Eight departments report to the City Manager, which include: Community Development, Parks and Recreation, Police, Public Works, City Manager's Office, Communications/City Clerk, Financial Services/City Treasurer and Human Resources. The Fire Department has transitioned to the San Mateo Consolidated Fire (SMC Fire) Department, serving Foster City, Belmont and San Mateo. The City has an all funds budget of \$196 million for FY 20-21 as well as a General Fund budget of \$44.5 million.



The Estero Municipal Improvement District (EMID) was created in 1960 and granted most of the governing powers associated with an incorporated municipality. EMID sold bonds to finance the major improvements needed for development of the City. EMID provides water and sewer service to Foster City and water service to Mariner's Island and is a separate legal entity with the City Council serving as its Board of Directors and the City Manager also serving as District Manager.

## The Position and Ideal Candidate

The City of Foster City seeks a seasoned and dynamic leader to serve as its next City Manager during a unique time of challenges and opportunities. The City, like all cities, is facing a period of increased financial uncertainty due to the economic fallout of COVID-19 pandemic and will have to adapt the organization to meet these challenges while still providing high level services to the community. The next City Manager will lead a young, mostly new, and highly skilled City staff in a collaborative and team-oriented fashion with a focus on mentorship and organizational development. While this is a unique moment, there are numerous opportunities for the next leader to shape the organization and move the City forward into the future.

The next City Manager will be expected to have an experienced and well-rounded background in all areas of city management. A track record of leadership success, improving organizational effectiveness and ensuring financial security will be beneficial to succeed in this role. It will be crucial for the seasoned leader to have a skill set in improving organizational efficiency and workflows as well as an understanding how to improve organizational development initiatives to continue to develop internal talent. The ideal candidate will also have a strong strategic acumen coupled with a high level of financial, budgetary and capital improvements knowledge.

Relationship building both internally and externally will also be critical to success in this role. The new City Manager will be expected to have excellent communication skills and to build strong relationships with department heads and ensure that there are clear lines of communication throughout the organization. This individual will be expected to be an executive that will empower department heads and their teams and give them the space to grow and develop while still having effective command presence. He/she will also build effective relationships with the Council and the wider group of community stakeholders. The new leader will be expected to effectively advise the Council on all matters of policy and build a trustworthy relationship with all Council Members. The next Manager will be politically astute, but apolitical.



A clear communicator who effectively builds partnerships buttressed by a track record of effectiveness would be the ideal next City Manager for Foster City. The individual must also have a strong belief in building a culture of collaboration and mentorship within the organization. The new leader will also possess personal values that are highly ethical and have a commitment to public service and the community.

Required qualifications for this position are eight years of increasingly responsible experience in public administration, which includes at least three years as a City Manager, Assistant City Manager, or Deputy thereof; or five years' experience in a responsible executive management position in government. Graduation from a recognized college or university with a BS/BA degree in Business Administration or Public Administration, MBA/MPA preferred. Graduate education may be substituted for experience on a year for year basis.

## Compensation and Benefits

Salary is negotiable DOQ (current maximum is \$256,308). While also negotiable, the City of Foster City offers a competitive management benefits package that includes:

- ◆ Retirement Plan – The City participates in CalPERS with a 2.7% @ 55 for classic members with a current employee contribution of 8%. For new employees covered under PEPPRA, the retirement formula is 2% @ 62 with an employee contribution of 6.25%.
- ◆ Holidays – 12 days annually.
- ◆ Vehicle Allowance - City vehicle or a vehicle allowance of \$200 per month, as determined to be appropriate by the City Council/Board.
- ◆ Vacation – 15 days (1-5 service years); 16 days (6 service years); 17 days (7) service years); 18 days (8 service years), 19 days (9 service years); 20 days (10 service years); 21 days (11-15 service years); and 23 days (16 plus service years). Years of service for vacation accrual purposes will be negotiated by the successful candidate and Council/Board.
- ◆ Sick Leave – Employees shall accrue sick leave at a rate of five and two thirds (5.666) hours per calendar month for each month that the Employee has worked regularly scheduled hours. There shall be no maximum accumulation of sick leave.
- ◆ Administrative Leave – 56 hours annually.
- ◆ Deferred Compensation – Voluntary 457/401a/VEBA plans available. Match available with 401a.



## The Process

If you are interested in pursuing this unique and exceptional career opportunity, please visit the Avery Associates Career Portal on our website at [www.averyassoc.net/current-searches/](http://www.averyassoc.net/current-searches/) to upload your letter of interest, resume, and contact information, including email addresses for five work-related references. (We will not contact references until after an initial interview takes place.)

Bill Avery or Paul Kimura  
Avery Associates  
3½ N. Santa Cruz Ave., Suite A  
Los Gatos, CA 95030  
E-mail: [jobs@averyassoc.net](mailto:jobs@averyassoc.net)



The final filing date for this recruitment is September 30, 2020.

If you have any questions regarding this position, please contact Bill Avery or Paul Kimura at 408.399.4424 or email: [bill@averyassoc.net](mailto:bill@averyassoc.net) or [paulk@averyassoc.net](mailto:paulk@averyassoc.net).

# THE CITY OF PASO ROBLES



INVITES YOUR INTEREST FOR THE  
POSITION OF

**CITY MANAGER**

## The Community

El Paso de Robles, or “The Pass of the Oaks,” is located halfway between San Francisco and Los Angeles, in San Luis Obispo County. Paso Robles is surrounded by scenic rolling hills and California’s premier wine regions and is only 27 miles from beautiful beaches. This thriving community of over 30,000 actively engaged citizens possesses the benefits of a suburban-rural community while retaining a small-town feel and is one of California’s best kept secrets. With over 200 wineries nearby and a



bustling downtown with a variety of excellent restaurants and specialty retail, Paso Robles is fast becoming one of the most desirable and yet relatively affordable places to live, work, and play.

The City of Paso Robles has a long history with both wine and healing waters. Travel and Leisure magazine rated Paso Robles as one of the “25 Top Places to Visit for the Holidays”. Other accolades for Paso Robles include “America’s Healthiest Small Towns,” “Best Small Main Street Towns in America,” “America’s Happiest Cities,” “Best Food and Wine Festivals,” “Winery of the Year” (Tablas Creek, Justin), and “Brewery of the Year” (Firestone Walker Brewing, multiple times) among others. As these honors attest, Paso Robles and the Central Coast offer an unparalleled quality of life.

The City understands the importance of business development and works hard to attract commerce in a diverse array of industries. The economic outlook for Paso Robles continues to be strong. The housing market is robust and offers a wide array of housing choices including new neighborhoods, houses with acreage, infill, and charming Victorian homes, with a median home price of about \$550,000. Paso Robles also has excellent schools, both public and private. Approximately half an hour away is the nationally ranked Cal Poly in San Luis Obispo, and within the City

of Paso Robles is accredited Cuesta College (North County Campus).



## City Government

The City of Paso Robles is a general law city organized, formed, and incorporated under the laws of the State of California on March 11, 1889. It has a Council-Manager form of government where the City Council establishes policies, adopts ordinances and approves resolutions, makes land use decisions, approves agreements and contracts, sets water and sewer rates, and approves the City’s budget. The Council appoints a City Manager, who is the chief executive officer of the municipal corporation. The City Council consists of a Mayor, elected at-large every four years, and four Councilmembers, elected by district in staggered four year terms, all on a non-partisan basis.

The City has a current total annual budget of \$106.9M for fiscal year 2021, and a total of 229.66 FTEs across the departments of: Administrative Services, City Manager’s Office, Community Development, Community Services, Emergency Services, Police, and Public Works.

## The Position and Ideal Candidate

The City of Paso Robles is looking for an experienced and visionary City Manager to lead the City forward into an exciting future with tremendous opportunities.

Given the uncertain financial situation that the City will be in post-COVID, securing the City's long-term financial future will be of paramount importance for this role. The City acted proactively early in the pandemic to save money, and voters approved a one-cent general sales tax measure in November that will be in effect for 12 years unless ended sooner by voters. Moving forward, there will be continued

challenges with unfunded liabilities and uncertainty regarding revenue levels during and post-pandemic. The new City Manager will need to be a highly strategic thinker to help the City navigate this challenging landscape with limited resources while still delivering high quality services and tackling the long-term needs of the City. They will understand the City and its issues and opportunities.

Establishing a strong and effective working relationship with the City Council and developing and maintaining a positive connection with the community are also critical to this role. The City Manager will maintain a proactive and regular dialogue with the Council to ensure they are in "lock step" with the strategic and operational direction of the Council and community. The City Manager is also expected to provide guidance and operational recommendations towards efficient city operations. In order to ensure an effective relationship with the City Council, the new City Manager must establish relationships with all Councilmembers and ensure that all of them are treated equally.

This position will require a strategic forward thinker and creative problem solver with a positive, energetic, "get-it-done" spirit, and a hands-on leadership style based on engagement, empowerment, accountability, and results. An innovative, "fresh-thinker" who can bring forth creative approaches and new ideas would provide a positive spark and a sense of spirit and vitality to the City. The successful candidate will be an active, engaged manager and a relationship builder with a value system based on transparency, ethics, integrity, diversity, and a personal approach that engenders high levels of trust and confidence. They will be expected to foster a culture of collaboration across the organization and build an executive team that reflects that mission. Additionally, the new City Manager will be highly committed to staff development and a culture of mentorship.



The new City Manager will be a dedicated and proven public servant with strong financial, management, and administration skills. Excellent written and verbal communication and effective presentation skills are expected in this role. A background that includes seven or more years of staff management, including previous experience as a City Manager, Assistant/Deputy City Manager or public sector executive in a complex organization is required for this position. A BS/BA in a related field is required and a MS/MA is highly desired.

## Compensation and Benefits

The City of Paso Robles offers an attractive compensation and benefits package. The salary for this position is negotiable dependent on qualifications. The comprehensive benefits package includes the following:

- ◆ CalPERS Retirement: Classic members of CalPERS participate in a formula of 2% at 60, with the employee paying a 7% member contribution plus an additional cost sharing contribution of 3% (a total of 10%). Employees who meet the definition of new member pursuant to PEPRa participate in a formula of 2% at 62, with the employee paying one-half of the normal cost (currently 7%) contribution plus an additional cost sharing contribution of 3% (a total of 10%). An average of three highest years is used for final compensation calculation.
- ◆ Social Security: The City participates in Social Security.
- ◆ Vacation: Accrual of 80-200 hours per year based on years of service.
- ◆ Sick Leave: Accrual of 96 hours per year.
- ◆ Holidays: 12 days per year.
- ◆ Administrative Leave: 56 hours per year.
- ◆ Health Insurance: The City offers medical, dental, vision, and long-term disability.
- ◆ Life Insurance: \$200,000 policy paid for by the City.
- ◆ Deferred Compensation: The City contributes \$161.54 per pay period and will match up to an additional \$96.15 per pay period.
- ◆ Flexible Spending Account: Allows employees to pay for dependent care and un-reimbursed medical expenses on a pre-tax basis.
- ◆ Employee Assistance Program (EAP): The City pays 100% of cost.
- ◆ Auto Allowance: \$175.00 per month.



## The Process

To be considered for this exceptional career opportunity, please visit the Avery Associates Career Portal on our website at [www.averyassoc.net/current-searches/](http://www.averyassoc.net/current-searches/) to upload your letter of interest, resume and contact information, including email addresses for five work-related references (who will not be contacted until after an interview takes place).

Bill Avery or Bill Lopez  
Avery Associates  
3½ N. Santa Cruz Ave., Suite A  
Los Gatos, CA 95030  
E-mail: [jobs@averyassoc.net](mailto:jobs@averyassoc.net)

The final filing date for this recruitment is May 14, 2021.

If you have any questions regarding this position, please contact Bill Avery at 408.399.4424 or [bill@averyassoc.net](mailto:bill@averyassoc.net) or Bill Lopez at 408.888.4099 or [williaml@averyassoc.net](mailto:williaml@averyassoc.net).





The City of Sausalito  
*invites your interest for the position of*  
**CITY MANAGER**



## The Community of Sausalito

The City of Sausalito is a beautiful bay-front community known for its Mediterranean flair and breathtaking views. The City is nestled at the foot of the Golden Gate National Recreation area and within its 2.2 square miles, houses 7,000 residents and a robust year-round tourism industry. Located in Marin County just a short trip over the Golden Gate Bridge from San Francisco, Sausalito offers small-town charm with close-knit, community-oriented residents, as well as close proximity to a wide range of cultural opportunities.



Boasting a colorful history, Sausalito has a variety of natural features that define the City's distinct residential neighborhoods, harbors, waterfront, commercial districts, and the maritime-oriented office and industrial district. Victorian homes dotting the lower hillsides give way to modern redwood-and-glass creations clinging precariously to the ridgelines. Green hills and a beautiful waterfront bring focus to the City's lively downtown area, offering boutique shopping, over 25 unique restaurants, and art galleries. Sausalito is also home to the Bay Model, a 3-D model of the San Francisco Bay and Delta. The City's year-round event calendar includes the Sausalito Art Festival, considered one of the finest outdoor festivals in the country, the summer Jazz and Blues by the Bay Series and in December, the Lighted Yacht Parade. The City's economic vitality is augmented by a diverse range of retail, service, and light industrial entities supporting the local community.

Those seeking recreational activities need not look far. Within the town, there are walking tours, bike rentals, kayaking, and boating. The City's location in Marin County offers varied hiking opportunities, from the Marin Headlands to nearby Mount Tamalpais. The delights of Sonoma Wine Country and the big-city bustle of San Francisco are each only a short drive away. The combination of wooded hillsides, sweeping Bay views, and ideal location makes Sausalito a community of unparalleled charm and natural beauty.

## City Government

The City of Sausalito was incorporated in 1893 as a General Law City. The City operates under a Council-Manager form of government, with five elected, at-large Council Members that serve overlapping four-year terms. The Council annually elects one of the Council Members to serve as Mayor for one year.

Under the direction of the City Manager, city services include public safety (police and civil defense), streets, sanitary sewer, storm drainage, culture-recreation, library, public works, land use management, planning and zoning, and general administrative services. Fire protection and utility services are handled by Special Districts. The City's FY 2019-20 annual operating budget is almost \$35.2 million including an \$18.2 million General Fund and a staffing level of 64.3 FTE. The City Council and Management Team enjoy a united and highly effective working relationship that values trust, open communication and creativity.

## The Position and Ideal Candidate Profile

The City Council and City staff are dedicated to providing quality services and enhancing the lifestyle that makes Sausalito such a desirable community. The new City Manager will continue this focus on providing top notch services to the community in the midst of significant



transition due primarily to ongoing impacts of the Covid-19 pandemic. This presents a great opportunity for new, innovative approaches in providing city services and necessitates a greater focus on organizational efficiencies in the delivery of those services. It will also require exceptional financial and budget acumen in addressing the pandemic related financial and economic challenges.

Sausalito's city operation has been enhanced by the focus on a multi-year strategic plan that provides the blueprint for the City's annual goals and objectives. The Strategic Plan and the City's two-year budget cycle are now due for updates and will provide the opportunity to identify, introduce, and implement a more creative operational model for the organization. It's expected that technology, process streamlining, greater organizational efficiency, and shared municipal/regional services will be the cornerstones for this major change initiative. The nature of organizational change will require an exceptional leader that encourages information sharing, mentorship, accountability, professional development, strategic thinking, organizational advocacy, and calculated risk taking.



Among key priorities moving forward, the City's General Plan update anticipated for approval in early 2021, will need implementation as significant Zoning modifications have been incorporated. An updated Housing Element will be developed separately and will call for a significant increase in affordable housing stock. In the development review and permitting process, there is a desire to reduce approval cycle time while positively improving communications to clients. There will also be a greater focus on sustainability and environmental considerations at the local level, along with a strong pursuit in addressing social equity, diversity, and inclusion. Success in securing grants and other funding related to these areas will be expected.

The City Manager will develop an excellent working relationship with the City Council, regional partners, and a positive connection with the community. The new leader must maintain a proactive, regular two-way communication with the Council and be expected to effectively advise, counsel and as appropriate, advocate to the Council. This will ensure the Manager is in "lock step" with the strategic and operational direction of the Council and community. An exciting aspect of the new transition will be the presence of the new City Manager and three newly elected City Council members. On a regional level, collaboration with Marin County, other Marin cities, and neighboring jurisdictions and authorities, including Marin City, the Sausalito Marin City Sanitary District, and the Sausalito Marin City School District is essential.

This position will require a strategic forward thinker and creative problem-solving entrepreneur that has a positive, energetic and "get-it-done" spirit with a charismatic and flexible leadership style based on engagement, empowerment, and results. An innovative, energetic, "fresh-thinker" who can bring forth creative approaches and new ideas would provide a positive spark and a sense of spirit and vitality to the City. A strong systems and technology orientation will be an asset in identifying and implementing more productive, efficient and transparent solutions. The successful candidate will also have a value system based on collaboration, transparency, ethics and integrity, and a personal approach that engenders high levels of trust and confidence. The successful Manager will also be politically astute yet apolitical in his/her approach and will be an effective regional partner in advancing mutually beneficial initiatives.

The new Manager will be dedicated to public service and will bring strong financial acumen, excellent management, administration and budget skills, along with a solid generalist background in the areas of land use, capital programs, and sustainability/environmental issues. Excellent written and verbal communications and effective presentation skills are expected in this role. A background that includes seven or more years of executive and staff management including previous experience as a City Manager, Assistant/Deputy City Manager, public sector executive or private sector CEO/executive manager in a complex organization is required for this position. A BS/BA in a related field is required and an MS/MA is highly desired.



## Compensation and Benefits

The City of Sausalito offers an excellent compensation and benefits package. The salary range for this position is open and negotiable, DOQ. The City also provides an attractive benefits program that includes:

- ◆ CalPERS Retirement: 2.0% @55 for Classic PERS participants. Employee pays 7% of the employee share. 2.0% @ 62 for PEPRAs participants. Employee pays 50% of employee share. The City does not participate in Social Security.
- ◆ Total Health Plan: City will provide \$991.34 monthly for single coverage; \$1,724.15 monthly for employee and one dependent; \$2,143.79 for employee with more than one dependent. Employee may choose to waive coverage (if covered elsewhere) and receive payment equal to the Cafeteria Plan of Benefits for single employee credit.
- ◆ Vacation: Accrual at the rate of 136 hours annually during the first 10 years of service. Maximum accrual of 240 hours total.
- ◆ Administrative Leave: 120 hours per calendar year.
- ◆ Holidays: 10 designated holidays and 16 hours of floating holidays.
- ◆ Sick Leave: Accrual at the rate of eight (8) hours per month.
- ◆ Auto Allowance: \$400 per month.
- ◆ Additional Benefits Include: employee development reimbursement, life insurance, AD&D insurance, long-term disability insurance and more.



## The Process

To be considered for this exceptional career opportunity, please visit the Avery Associates Career Portal on our website at [www.averyassoc.net/current-searches/](http://www.averyassoc.net/current-searches/) to upload your letter of interest, resume and contact information, including email addresses for five work-related references (who will not be contacted until after an interview takes place).

Paul Kimura or Bill Lopez  
Avery Associates  
3½ N. Santa Cruz Ave., Suite A  
Los Gatos, CA 95030  
E-mail: [jobs@averyassoc.net](mailto:jobs@averyassoc.net)



The final filing date for this position has been extended to February 15, 2021.

Please contact Paul Kimura at [paulk@averyassoc.net](mailto:paulk@averyassoc.net) or 408.472.7936 or Bill Lopez at [williaml@averyassoc.net](mailto:williaml@averyassoc.net) or 408.888.4099 if you have any questions related to this position.

**CONSULTANT AGREEMENT**

City Manager's Office  
701 Laurel St., Menlo Park, CA 94025  
tel 650-330-6620



<b>Agreement #:</b>
<b>AGREEMENT FOR SERVICES BETWEEN THE CITY OF MENLO PARK AND _____</b>
THIS AGREEMENT made and entered into at Menlo Park, California, this _____, by and between the CITY OF MENLO PARK, a Municipal Corporation, hereinafter referred to as "CITY," and _____, hereinafter referred to as "FIRST PARTY."
<p>WITNESSETH:</p> <p>WHEREAS, CITY desires to retain FIRST PARTY to provide certain professional services for CITY in connection the recruitment of a city manager</p> <p>WHEREAS, FIRST PARTY has the professional expertise and experience to perform said services and desires to and does hereby undertake to perform said services.</p> <p>NOW, THEREFORE, IN CONSIDERATION OF THE MUTUAL COVENANTS, PROMISES AND CONDITIONS of each of the parties hereto, it is hereby agreed as follows:</p>
<b>1. SCOPE OF WORK</b>
In consideration of the payment by CITY to FIRST PARTY, as hereinafter provided, FIRST PARTY agrees to perform all the services as set forth in Exhibit "A," Scope of Services.
<b>2. SCHEDULE FOR WORK</b>
<p>FIRST PARTY's proposed schedule for the various services required pursuant to this agreement will be as set forth in Exhibit "A," Scope of Services. CITY will be kept informed as to the progress of work by written reports, to be submitted monthly or as otherwise required in Exhibit "A." Neither party shall hold the other responsible for damages or delay in performance caused by acts of God, strikes, lockouts, accidents or other events beyond the control of the other, or the other's employees and agents.</p> <p>FIRST PARTY shall commence work immediately upon receipt of a "Notice to Proceed" from CITY. The "Notice to Proceed" date shall be considered the "effective date" of the agreement, as used herein, except as otherwise specifically defined. FIRST PARTY shall complete all the work and deliver to CITY all project related files, records, and materials within one month after completion of all of FIRST PARTY's activities required under this agreement.</p>
<b>3. PROSECUTION OF WORK</b>
FIRST PARTY will employ a sufficient staff to prosecute the work diligently and continuously and will complete the work in accordance with the schedule of work approved by the CITY. (See Exhibit "A," Scope of Services).

#### 4. COMPENSATION AND PAYMENT

- A. CITY shall pay FIRST PARTY an hourly fee that shall not exceed \$ \_\_\_\_\_ as described in Exhibit "A," Scope of Services. All payments shall be inclusive of all indirect and direct charges to the Project incurred by FIRST PARTY. The CITY reserves the right to withhold payment if the City determines that the quantity or quality of the work performed is unacceptable.
- B. FIRST PARTY's fee for the services as set forth herein shall be considered as full compensation for all indirect and direct personnel, materials, supplies and equipment, and services incurred by FIRST PARTY and used in carrying out or completing the work.
- C. Payments shall be monthly for the invoice amount or such other amount as approved by CITY. As each payment is due, the FIRST PARTY shall submit a statement describing the services performed to CITY. This statement shall include, at a minimum, the project title, agreement number, the title(s) of personnel performing work, hours spent, payment rate, and a listing of all reimbursable costs. CITY shall have the discretion to approve the invoice and the work completed statement. Payment shall be for the invoice amount or such other amount as approved by CITY.
- D. Payments are due upon receipt of written invoices. CITY shall have the right to receive, upon request, documentation substantiating charges billed to CITY. CITY shall have the right to perform an audit of the FIRST PARTY's relevant records pertaining to the charges.

#### 5. EQUAL EMPLOYMENT OPPORTUNITY

- A. FIRST PARTY, with regard to the work performed by it under this agreement shall not discriminate on the grounds of race, religion, color, national origin, sex, handicap, marital status or age in the retention of sub-consultants, including procurement of materials and leases of equipment.
- B. FIRST PARTY shall take affirmative action to insure that employees and applicants for employment are treated without regard to their race, color, religion, sex, national origin, marital status or handicap. Such action shall include, but not be limited to the following: employment, upgrading, demotion, or transfer; recruitment advertising; layoff or termination; rates of pay or other forms of compensation and selection for training including apprenticeship.
- C. FIRST PARTY shall post in prominent places, available to employees and applicants for employment, notices setting forth the provisions of this non-discrimination clause.
- D. FIRST PARTY shall state that all qualified applications will receive consideration for employment without regard to race, color, religion, sex, national origin, marital status or handicap.
- E. FIRST PARTY shall comply with Title VI of the Civil Rights Act of 1964 and shall provide such reports as may be required to carry out the intent of this section.
- F. FIRST PARTY shall incorporate the foregoing requirements of this section in FIRST PARTY's agreement with all sub-consultants.

#### 6. ASSIGNMENT OF AGREEMENT AND TRANSFER OF INTEREST

- A. FIRST PARTY shall not assign this agreement, and shall not transfer any interest in the same (whether by assignment or novation), without prior written consent of the CITY thereto, provided, however, that claims for money due or to become due to the FIRST PARTY from the CITY under this agreement may be assigned to a bank, trust company, or other financial institution without such approval. Notice of an intended assignment or transfer shall be furnished promptly to the CITY.
- B. In the event there is a change of more than 30 percent of the stock ownership or ownership in FIRST PARTY from the date of this agreement is executed, then CITY shall be notified before the date of said change of stock ownership or interest and CITY shall have the right, in event of such change in stock ownership or interest, to terminate this agreement upon notice to FIRST PARTY. In the event CITY is not notified of any such change in stock ownership or interest, then upon knowledge of same, it shall be deemed that CITY has terminated this agreement.

## 7. INDEPENDENT WORK CONTROL

It is expressly agreed that in the performance of the service necessary for compliance with this agreement, FIRST PARTY shall be and is an independent contractor and is not an agent or employee of CITY. FIRST PARTY has and shall retain the right to exercise full control and supervision of the services and full control over the employment, direction, compensation and discharge of all persons assisting FIRST PARTY in the performance of FIRST PARTY's services hereunder. FIRST PARTY shall be solely responsible for its own acts and those of its subordinates and employees.

## 8. CONSULTANT QUALIFICATIONS

It is expressly understood that FIRST PARTY is licensed and skilled in the professional calling necessary to perform the work agreed to be done by it under this agreement and CITY relies upon the skill of FIRST PARTY to do and perform said work in a skillful manner usual to the profession. The acceptance of FIRST PARTY's work by CITY does not operate as a release of FIRST PARTY from said understanding.

## 9. NOTICES

All notices hereby required under this agreement shall be in writing and delivered in person or sent by certified mail, postage prepaid or by overnight courier service. Notices required to be given to CITY shall be addressed as follows:

Judi Herren  
 City Clerk  
 City of Menlo Park  
 701 Laurel St.  
 Menlo Park, CA 94025  
 650-330-2510  
 jherren@menlopark.org

Notices required to be given to FIRST PARTY shall be addressed as follows:

[FILL IN]

Provided that any party may change such address by notice, in writing, to the other party and thereafter notices shall be addressed and transmitted to the new address.

## 10. HOLD HARMLESS

The FIRST PARTY shall defend, indemnify and hold harmless the CITY, its subsidiary agencies, their officers, agents, employees and servants from all claims, suits or actions that arise out of, pertain to, or relate to the negligence, recklessness, or willful misconduct of the FIRST PARTY brought for, or on account of, injuries to or death of any person or damage to property resulting from the performance of any work required by this agreement by FIRST PARTY, its officers, agents, employees and servants. Nothing herein shall be construed to require the FIRST PARTY to defend, indemnify or hold harmless the CITY, its subsidiary agencies, their officers, agents, employees and servants against any responsibility to liability in contravention of Section 2782.8 of the California Civil Code.

## 11. INSURANCE

- A. FIRST PARTY shall not commence work under this agreement until all insurance required under this Section has been obtained and such insurance has been approved by the City, with certificates of insurance evidencing the required coverage.
- B. There shall be a contractual liability endorsement extending the FIRST PARTY's coverage to include the contractual liability assumed by the FIRST PARTY pursuant to this agreement. These certificates shall specify or be endorsed to provide that thirty (30) days' notice must be given, in writing, to the CITY, at the address shown in Section 9, of any pending cancellation of the policy. FIRST PARTY shall notify CITY of any pending change to the policy. All certificates shall be filed with the City.
1. Workers' compensation and employer's liability insurance:  
The FIRST PARTY shall have in effect during the entire life of this agreement workers' compensation and Employer's Liability Insurance providing full statutory coverage. In signing this agreement, the FIRST PARTY makes the following certification, required by Section 18161 of the California Labor Code: "I am aware of the provisions of Section 3700 of the California Labor Code which require every employer to be insured against liability for workers' compensation or to undertake self-insurance in accordance with the provisions of the Code, and I will comply with such provisions before commencing the performance of the work of this agreement" (not required if the FIRST PARTY is a Sole Proprietor).
  2. Liability insurance:  
The FIRST PARTY shall take out and maintain during the life of this agreement such Bodily Injury Liability and Property Damage Liability Insurance (Commercial General Liability Insurance) on an occurrence basis as shall protect it while performing work covered by this agreement from any and all claims for damages for bodily injury, including accidental death, as well as claims for property damage which may arise from the FIRST PARTY's operations under this agreement, whether such operations be by FIRST PARTY or by any sub-consultant or by anyone directly or indirectly employed by either of them. The amounts of such insurance shall be not less than one million dollars (\$1,000,000) per occurrence and one million dollars (\$1,000,000) in aggregate, or one million dollars (\$1,000,000) combined single limit bodily injury and property damage for each occurrence. FIRST PARTY shall provide the CITY with acceptable evidence of coverage, including a copy of all declarations of coverage exclusions. FIRST PARTY shall maintain Automobile Liability Insurance pursuant to this agreement in an amount of not less than one million dollars (\$1,000,000) for each accident combined single limit or not less than one million dollars (\$1,000,000) for any one (1) person, and one million dollars (\$1,000,000) for any one (1) accident, and Three Hundred Thousand Dollars, (\$300,000) property damage.
  3. Professional liability insurance:  
FIRST PARTY shall maintain a policy of professional liability insurance, protecting it against claims arising out of the negligent acts, errors, or omissions of FIRST PARTY pursuant to this agreement, in the amount of not less than one million dollars (\$1,000,000) per claim and in the aggregate. Said professional liability insurance is to be kept in force for not less than one (1) year after completion of services described herein.
- C. CITY and its subsidiary agencies, and their officers, agents, employees and servants shall be named as additional insured on any such policies of Commercial General Liability and Automobile Liability Insurance, (but not for the Professional Liability and workers' compensation), which shall also contain a provision that the insurance afforded thereby to the CITY, its subsidiary agencies, and their officers, agents, employees, and servants shall be primary insurance to the full limits of liability of the policy, and that if the CITY, its subsidiary agencies and their officers and employees have other insurance against a loss covered by a policy, such other insurance shall be excess insurance only.
- D. In the event of the breach of any provision of this Section, or in the event any notice is received which indicates any required insurance coverage will be diminished or canceled, CITY, at its option, may, notwithstanding any other provision of this agreement to the contrary, immediately declare a material breach of this agreement and suspend all further work pursuant to this agreement.
- E. Before the execution of this agreement, any deductibles or self-insured retentions must be declared to and approved by CITY.

## 12. PAYMENT OF PERMITS/LICENSES

Contractor shall obtain any license, permit, or approval if necessary from any agency whatsoever for the work/services to be performed, at his/her own expense, before commencement of said work/services or forfeit any right to compensation under this agreement.

## 13. RESPONSIBILITY AND LIABILITY FOR SUB-CONSULTANTS AND/OR SUBCONTRACTORS

Approval of or by CITY shall not constitute nor be deemed a release of responsibility and liability of FIRST PARTY or its sub-consultants and/or subcontractors for the accuracy and competency of the designs, working drawings, specifications or other documents and work, nor shall its approval be deemed to be an assumption of such responsibility by CITY for any defect in the designs, working drawings, specifications or other documents prepared by FIRST PARTY or its sub-consultants and/or subcontractors.

## 14. OWNERSHIP OF WORK PRODUCT

Work products of FIRST PARTY for this project, which are delivered under this agreement or which are developed, produced and paid for under this agreement, shall become the property of CITY. The reuse of FIRST PARTY's work products by City for purposes other than intended by this agreement shall be at no risk to FIRST PARTY.

## 15. REPRESENTATION OF WORK

Any and all representations of FIRST PARTY, in connection with the work performed or the information supplied, shall not apply to any other project or site, except the project described in Exhibit "A" or as otherwise specified in Exhibit "A."

## 16. TERMINATION OF AGREEMENT

- A. CITY may give thirty (30) days written notice to FIRST PARTY, terminating this agreement in whole or in part at any time, either for CITY's convenience or because of the failure of FIRST PARTY to fulfill its contractual obligations or because of FIRST PARTY's change of its assigned personnel on the project without prior CITY approval. Upon receipt of such notice, FIRST PARTY shall:
1. Immediately discontinue all services affected (unless the notice directs otherwise); and
  2. Deliver to the CITY all data, drawings, specifications, reports, estimates, summaries, and such other information and materials as may have been accumulated or produced by FIRST PARTY in performing work under this agreement, whether completed or in process.
- B. If termination is for the convenience of CITY, an equitable adjustment in the contract price shall be made, but no amount shall be allowed for anticipated profit on unperformed services.
- C. If the termination is due to the failure of FIRST PARTY to fulfill its agreement, CITY may take over the work and prosecute the same to completion by agreement or otherwise. In such case, FIRST PARTY shall be liable to CITY for any reasonable additional cost occasioned to the CITY thereby.
- D. If, after notice of termination for failure to fulfill agreement obligations, it is determined that FIRST PARTY had not so failed, the termination shall be deemed to have been effected for the convenience of the CITY. In such event, adjustment in the contract price shall be made as provided in Paragraph B of this Section.
- E. The rights and remedies of the CITY provided in this Section are in addition to any other rights and remedies provided by law or under this agreement.
- F. Subject to the foregoing provisions, the CITY shall pay FIRST PARTY for services performed and expenses incurred through the termination date.



**17. INSPECTION OF WORK**

It is FIRST PARTY's obligation to make the work product available for CITY's inspections and periodic reviews upon request by CITY.

**18. COMPLIANCE WITH LAWS**

It shall be the responsibility of FIRST PARTY to comply with all State and Federal Laws applicable to the work and services provided pursuant to this agreement, including but not limited to compliance with prevailing wage laws, if applicable.

**19. BREACH OF AGREEMENT**

- A. This agreement is governed by applicable federal and state statutes and regulations. Any material deviation by FIRST PARTY for any reason from the requirements thereof, or from any other provision of this agreement, shall constitute a breach of this agreement and may be cause for termination at the election of the CITY.
- B. The CITY reserves the right to waive any and all breaches of this agreement, and any such waiver shall not be deemed a waiver of any previous or subsequent breaches. In the event the CITY chooses to waive a particular breach of this agreement, it may condition same on payment by FIRST PARTY of actual damages occasioned by such breach of agreement.

**20. SEVERABILITY**

The provisions of this agreement are severable. If any portion of this agreement is held invalid by a court of competent jurisdiction, the remainder of the agreement shall remain in full force and effect unless amended or modified by the mutual consent of the parties.

**21. CAPTIONS**

The captions of this agreement are for convenience and reference only and shall not define, explain, modify, limit, exemplify, or aid in the interpretation, construction, or meaning of any provisions of this agreement.

**22. LITIGATION OR ARBITRATION**

The Dispute Resolution provisions are set forth on Exhibit "B," 'Dispute Resolution' attached hereto and by this reference incorporated herein.

**23. RETENTION OF RECORDS**

Contractor shall maintain all required records for three years after the City makes final payment and all other pending matters are closed, and shall be subject to the examination and /or audit of the City, a federal agency, and the state of California.

**24. TERM OF AGREEMENT**

This agreement shall remain in effect for the period of \_\_\_\_\_, 2021 through \_\_\_\_\_, 2022 unless extended, amended, or terminated in writing by CITY.

**25. ENTIRE AGREEMENT**

This document constitutes the sole agreement of the parties hereto relating to said project and states the rights, duties, and obligations of each party as of the document's date. Any prior agreement, promises, negotiations, or representations between parties not expressly stated in this document are not binding. All modifications, amendments, or waivers of the terms of this agreement must be in writing and signed by the appropriate representatives of the parties to this agreement.

IN WITNESS WHEREOF, the parties hereto have executed this agreement on the day and year first above written.

**FOR FIRST PARTY:**

\_\_\_\_\_  
Signature

\_\_\_\_\_  
Date

\_\_\_\_\_  
Printed name

\_\_\_\_\_  
Title

\_\_\_\_\_  
Tax ID#

**APPROVED AS TO FORM:**

\_\_\_\_\_  
Nira F. Doherty, City Attorney

\_\_\_\_\_  
Date

**FOR CITY OF MENLO PARK:**

\_\_\_\_\_  
Mayor, Drew Combs

\_\_\_\_\_  
Date

**ATTEST:**

\_\_\_\_\_  
Judi A. Herren, City Clerk

\_\_\_\_\_  
Date

**EXHIBIT “A” – SCOPE OF SERVICES**

**A1. SCOPE OF WORK**

FIRST PARTY agrees to provide consultant services for CITY’s City Manager’s Department . In the event of any discrepancy between any of the terms of the FIRST PARTY’s proposal and those of this agreement, the version most favorable to the CITY shall prevail. FIRST PARTY shall provide the following services:

Provide consultant services set forth in Exhibit A -1, attached hereto.

FIRST PARTY agrees to perform these services as directed by the CITY in accordance with the standards of its profession and CITY’s satisfaction.

**A2. COMPENSATION**

CITY shall pay FIRST PARTY a not to exceed fee of \$Click here to enter text.. All payments, including fixed hourly rates, shall be inclusive of all indirect and direct charges to the Project incurred by FIRST PARTY. The CITY reserves the right to withhold payment if the CITY determines that the quantity or quality of the work performed is unacceptable.

FIRST PARTY’s fee for the services as set forth herein shall be considered as full compensation for all indirect and direct personnel, materials, supplies and equipment, and serviced incurred by FIRST PARTY and used in carrying out or completing the work.

Payments shall be monthly for the invoice amount or such amount as approved by CITY. As each payment is due, FIRST PARTY shall submit a statement describing the services performed to CITY. This statement shall include, at minimum, the project title, agreement number, the title(s) pf personnel performing work, hours spent, payment rate, and a listing of all reimbursable costs. Payment shall be for the invoice amount or such other amount as approved by the CITY.

Payments are due upon receipt of written invoices. CITY shall have the right to receive, upon request, documentation substantiating charges bulled to CITY. CITY shall have the right to perform an audit of the FIRST PARTY’s relevant records pertaining to the charges.

**A3. SCHEDULE OF WORK**

FIRST PARTY’S proposed schedule for the various services required will be set forth in Exhibit A-1.

#### **A4. CHANGES IN WORK -- EXTRA WORK**

In addition to services described in Section A1, the parties may from time to time agree in writing that FIRST PARTY, for additional compensation, shall perform additional services including but not limited to:

- Change in the services because of changes in scope of the work.
- Additional tasks not specified herein as required by the CITY.

The CITY and FIRST PARTY shall agree in writing to any changes in compensation and/or changes in FIRST PARTY's services before the commencement of any work. If FIRST PARTY deems work he/she has been directed to perform is beyond the scope of this agreement and constitutes extra work, FIRST PARTY shall immediately inform the CITY in writing of the fact. The CITY shall make a determination as to whether such work is in fact beyond the scope of this agreement and constitutes extra work. In the event that the CITY determines that such work does constitute extra work, it shall provide compensation to the FIRST PARTY in accordance with an agreed cost that is fair and equitable. This cost will be mutually agreed upon by the CITY and FIRST PARTY. A supplemental agreement providing for such compensation for extra work shall be negotiated between the CITY and the FIRST PARTY. Such supplemental agreement shall be executed by the FIRST PARTY and may be approved by the City Manager upon recommendation of the Theresa DellaSanta, Interim Assistant Community Services Director.

#### **A5. BILLINGS**

FIRST PARTY's bills shall include the following information: A brief description of services performed, project title and the agreement number; the date the services were performed; the number of hours spent and by whom; the current contract amount; the current invoice amount; Except as specifically authorized by CITY, FIRST PARTY shall not bill CITY for duplicate services performed by more than one person. In no event shall FIRST PARTY submit any billing for an amount in excess of the maximum amount of compensation provided in Section A2.

The expenses of any office, including furniture and equipment rental, supplies, salaries of employees, telephone calls, postage, advertising, and all other expenses incurred by FIRST PARTY in the performances of this agreement shall be incurred at the FIRST PARTY's discretion. Such expenses shall be FIRST PARTY's sole financial responsibility.

**EXHIBIT "B" - DISPUTE RESOLUTION**

- B1.0** All claims, disputes and other matters in question between the FIRST PARTY and CITY arising out of, or relating to, the contract documents or the breach thereof, shall be resolved as follows:
- B2.0 Mediation**
- B2.1** The parties shall attempt in good faith first to mediate such dispute and use their best efforts to reach agreement on the matters in dispute. After a written demand for non-binding mediation, which shall specify in detail the facts of the dispute, and within ten (10) days from the date of delivery of the demand, the matter shall be submitted to a mutually agreeable mediator. The Mediator shall hear the matter and provide an informal opinion and advice, none of which shall be binding upon the parties, but is expected by the parties to help resolve the dispute. Said informal opinion and advice shall be submitted to the parties within twenty (20) days following written demand for mediation. The Mediator's fee shall be shared equally by the parties. If the dispute has not been resolved, the matter shall be submitted to arbitration in accordance with Paragraph B3.1.
- B3.0 Arbitration**
- B3.1** Any dispute between the parties that is to be resolved by arbitration as provided in Paragraph B2.1 shall be settled and decided by arbitration conducted by the American Arbitration Association in accordance with the Construction Industry Arbitration Rules of the American Arbitration Association, as then in effect, except as provided below. Any such arbitration shall be held before three arbitrators who shall be selected by mutual agreement of the parties; if agreement is not reached on the selection of the arbitrators within fifteen (15) days, then such arbitrator(s) shall be appointed by the presiding Judge of the court of jurisdiction of the agreement.
- B3.2** The provisions of the Construction Industry Arbitration Rules of the American Arbitration Association shall apply and govern such arbitration, subject, however to the following:
- B3.3** Any demand for arbitration shall be writing and must be made within a reasonable time after the claim, dispute or other matter in question as arisen. In no event shall the demand for arbitration be made after the date that institution of legal or equitable proceedings based on such claim, dispute or other matter would be barred by the applicable statute of limitations.
- B3.4** The arbitrator or arbitrators appointed must be former or retired judges, or attorneys at law with last ten (10) years' experience in construction litigation.
- B3.5** All proceedings involving the parties shall be reported by a certified shorthand court reporter, and written transcripts of the proceedings shall be prepared and made available to the parties.
- B3.6** The arbitrator or arbitrators must be made within and provide to the parties factual findings and the reasons on which the decisions of the arbitrator or arbitrators is based.
- B3.7** Final decision by the arbitrator or arbitrators must be made within ninety (90) days from the date of the arbitration proceedings are initiated.
- B3.8** The prevailing party shall be awarded reasonable attorneys' fees, expert and non-expert witness costs and expenses, and other costs and expenses incurred in connection with the arbitration, unless the arbitrator or arbitrators for good cause determine otherwise.
- B3.9** Costs and fees of the arbitrator or arbitrators shall be borne by the non-prevailing party, unless the arbitrator or arbitrators for good cause determine otherwise.
- B3.10** The award or decision of the arbitrator or arbitrators, which may include equitable relief, shall be final, and judgment may be entered on it in accordance with applicable law in any court having jurisdiction over the matter.

**Colleagues Memo**

Date: August 13, 2021

To: Mayor Combs, Vice Mayor Nash and City Councilmember Mueller

From: City Councilmembers Taylor and Wolosin

Subject: Recommendations for Next Steps for City Manager Recruitment

**Background and Discussion**Request for Proposals

During Closed Session on June 10, 2021, the City Manager's upcoming retirement was discussed and it was determined that a search for a new City Manager would commence. The City Council designated Councilmembers Taylor and Wolosin to develop a Request for Proposals (RFP) for a firm to recruit for this position. On July 14, 2021, an RFP was issued (See Attachment A).

A total of six proposals were submitted from recruitment firms by the deadline of August 6, 2021. See table below for a list of firms that submitted proposals.

<b>Firm Name</b>
Avery & Associates
Bob Murray & Associates
CPS HR Consulting
The Hawkins Company
Koff & Associates
Ralph Anderson & Associates

After an initial review of the proposals, Councilmembers Taylor and Wolosin decided to continue consideration of five of the six firms. Koff & Associates was not pursued due to their recent merger and unclear recruiter designation/experience.

References

Councilmembers Taylor and Wolosin made multiple attempts to reach references provided by the remaining five firms during the week of August 9th and connected with at least one reference for each firm, and in most cases up to three.

### Interviews

One hour interviews were conducted with each of the five firms under consideration on Wednesday, August 11th and Thursday, August 12th. The Councilmembers used the same set of questions during each interview (See Attachment B).

Councilmembers Taylor and Wolosin were impressed by each of the firm's background, experience and team, and acknowledge that all of the firms represent viable options for this recruitment. Each of the firms has successfully conducted many comparable recruitments and all of their timelines and processes were relatively similar.

### **Recommendations**

While Councilmembers Taylor and Wolosin found all five firms to be accomplished, personable and more than able to recruit for an executive level position in municipal government, one firm stood out from the rest. Councilmembers Taylor and Wolosin recommend that the Council enter into an agreement with The Hawkins Company.

The Hawkins Company is a values-based firm that specializes in diversity recruiting and complex assignments. They have a vast and inclusive network of candidates to draw from and they have experience and success recruiting an expansive pool of candidates that meets unique and specific needs. Their understanding of the entire community of Menlo Park, including strengths and challenges, demonstrates their research skills and deep analytical abilities. The team assembled to conduct the recruitment is dynamic, intuitive and possesses the capacity and enthusiasm to meet Menlo Park's goals. The three references reached/checked reinforced the positive impression made by the firm.

The Hawkins Company is the ideal firm to "meet the moment" in Menlo Park. As Menlo Park manages its growth and works to move towards a more equitable future, the guidance and expertise of The Hawkins Company will be invaluable.

The cost of the contract is \$32,000, which includes a community survey. Estimated reimbursable expenses are an additional \$7,500. For comparison, the other firms' costs, including an online survey, ranged from \$18,000 to \$36,000 plus \$3,500 to \$7,000 of additional costs). The Hawkins Company also offers six months of post placement coaching for the candidate that is hired for an additional \$6,000. Councilmembers Taylor and Wolosin recommend adding on this offering. The total cost (professional fee, estimated reimbursable expenses and 6 months of post placement coaching) is \$45,500.

It is further recommended that Councilmembers Taylor and Wolosin serve on the City Manager Recruitment Council Subcommittee for the duration of the recruitment process. This would entail serving as a liaison between the recruitment firm and the Council, helping to narrow the list of candidates for the entire Council to interview (based on full-Council agreed upon criteria) and performing other tasks as needed.

Attachment

A: RFP for Recruitment Firm:

<https://www.menlopark.org/DocumentCenter/View/29190/RFP---City-Manager-Recruitment-Services?bidId=162>.

B: Interview Questions: See Attachment B



## Interview Questions for Recruitment Firms

### Menlo Park

1. How would you describe Menlo Park?
2. What cities have you recruited for that resemble Menlo Park? What were the specific challenges?
3. What challenges do you foresee Menlo Park having in attracting talent? What strategies and tactics will you use to attract candidates to our high cost of living area?
4. What is appealing to you about this assignment? What excites you about this recruitment?

### Diversity

5. Menlo Park is committed to being an all inclusive city where all are welcome. How has your firm ensured that your recruitment process is inclusive of candidates of all backgrounds (including those with physical challenges)? How have you operationalized best practices?
6. Tell us about a time when you conducted a recruitment that was unsuccessful in finding a diverse pool of candidates. What did you do about it/learn from it?
7. Tell us about a time when you hired a City Manager who was not from municipal government (outside the typical pool)?
8. What DEI training have you and your firm been through?

### Community Outreach

9. How important is community outreach in the recruitment of a City Manager?
10. How do you ensure that historically underrepresented groups are heard?

### Council

11. How do you reflect all 5 councilmembers' perspectives in the candidate profile? How are the wish lists incorporated, how do you prioritize? Please walk us through that process.
12. How is recruiting for a Strong City Manager form of government different from a Strong Mayor city?

### The Firm

13. Can you confirm that YOU will be the lead on this project?
14. How does your team work together? What makes your team dynamic?
15. How many other recruitments do you have in process? How will you ensure that this recruitment is a priority?

### Example Call

16. Given our discussion about Menlo Park and what you know, please do a mock call for us to a prospective candidate so we can see how you will approach candidates about our city. Please feel free to use up to 3 minutes.

### Anything Else

17. Anything else you would like to add?

### Questions for Us

18. Do you have any questions for us?



## STAFF REPORT

### City Council

Meeting Date:

8/17/2021

Staff Report Number:

21-148-CC

### Regular Business:

**Adopt Resolution No. 6650 of the City Council of the City of Menlo Park determining that the City Council shall take an appeal of the Planning Commission's June 21, 2021, approval of the Menlo Uptown Development Project**

### Recommendation

Adopt Resolution No. 6650, a resolution of the City Council of the City of Menlo Park determining that the City Council shall take an appeal of the Planning Commission's June 21, 2021, approval of the Menlo Uptown Development Project.

### Policy Issues

There are no policy issues related to this item.

### Background

Pursuant to Menlo Park Municipal Code (MPMC) 16.86.025, any City Councilmember may file an appeal of any final action of the planning commission by filing an appeal with the city clerk within 15 days after the action of the planning commission. The question of whether such appeal of any City Councilmember shall be a City Council appeal shall be determined by the City Council as soon as practicable at a regular council meeting (MPMC § 16.86.025.) On July 6, 2021, City Councilmember Taylor timely filed an appeal of the Planning Commission's June 21, 2021, approval of the Menlo Uptown development project.

### Analysis

Pursuant to MPMC 16.86.025, the City Council must determine whether City Councilmember Taylor's appeal of the Planning Commission's June 21, 2021, approval of the Menlo Uptown development project shall be a City Council appeal. The attached Resolution No. 6650 would determine that the City Council elects to take an appeal of the Planning Commission's June 21, 2021, action.

### Impact on City Resources

There is no impact on City resources.

### Environmental Review

This action is not a project within the meaning of the California Environmental Quality Act (CEQA) Guidelines §§ 15378 and 15061(b)(3) as it will not result in any direct or indirect physical change in the

environment.

**Public Notice**

Public notification was achieved by posting the agenda, with the agenda items being listed, at least 72 hours prior to the meeting.

**Attachments**

A. Resolution No. 6650

Report prepared by:  
Nira Doherty, City Attorney

**RESOLUTION NO. 6650**

**RESOLUTION OF THE CITY COUNCIL OF THE CITY OF MENLO PARK DETERMINING THAT THE CITY COUNCIL SHALL TAKE AN APPEAL OF THE PLANNING COMMISSION'S JUNE 21, 2021 APPROVAL OF THE MENLO UPTOWN DEVELOPMENT PROJECT**

WHEREAS, pursuant to Menlo Park Municipal Code (MPMC) 16.86.025, any City Councilmember may file an appeal of any final action of the planning commission by filing an appeal with the city clerk within fifteen (15) days after the action of the planning commission; and

WHEREAS, pursuant to MPMC section 16.86.025, the question of whether such appeal of any Councilmember shall be a City Council appeal shall be determined by the City Council as soon as practicable at a regular city council meeting; and

WHEREAS, on June 21, 2021, the Menlo Park Planning Commission approved the Menlo Uptown Development Project by adopting Resolution No. 2021-03 and Resolution No. 2021-04 (hereinafter the "Project"); and

WHEREAS, pursuant to MPMC section 16.86.025, City Councilmember Taylor timely filed an appeal of the Planning Commission's June 21, 2021 approval of the Project by filing with the city clerk said appeal on July 6, 2021 (Exhibit A); and

WHEREAS, without taking a position on the merits of an appeal, and in order that the City Council serve as the final decision-maker on the Project, the City Council wishes to call-up the Project for final review and approval by the City Council

NOW THEREFORE, BE IT RESOLVED, that the City Council of the City of Menlo Park hereby resolves that Councilmember Taylor's appeal of the Planning Commission's June 21, 2021 approval of the Project shall be a City Council appeal.

SEVERABILITY

If any term, provision, or portion of these findings or the application of these findings to a particular situation is held by a court to be invalid, void or unenforceable, the remaining provisions of these findings, or their application to other actions related to the Project, shall continue in full force and effect unless amended or modified by the City.

//

//

//

//

I, Judi A. Herren, City Clerk of Menlo Park, do hereby certify that the above and foregoing City Council Resolution was duly and regularly passed and adopted at a meeting by said City Council on the seventeenth day of August, 2021, by the following votes:

AYES:

NOES:

ABSENT:

ABSTAIN:

IN WITNESS WHEREOF, I have hereunto set my hand and affixed the Official Seal of said City on this seventeenth day of August, 2021.

---

Judi A. Herren, City Clerk

**Herren, Judi A**

---

**From:** Taylor, Cecilia  
**Sent:** Tuesday, July 6, 2021 4:49 PM  
**To:** Combs, Drew; Doherty, Nira F; Jerome-Robinson, Starla L; Herren, Judi A  
**Subject:** Quest to call up project Menlo uptown

Good afternoon Mayor, City Manager, City Attorney, and City Clerk,

I am requesting to Call Up project Menlo Uptown for the following reasons:

1. Concerns about upcoming development and water shortages due too drought.
2. In District one, there is an extreme heat and climate crisis concern and we do not have a emergency preparedness plan nor to mitigate existing conditions.
3. Naming rights on the urgent care facility by District 1 Residents.
4. Transportation issues and improvements must happen within the Belle Haven neighborhood prior to project completion.
5. Non-community members negotiating community amenities on the behalf of a community that have not reached out.
6. The existing below market rate policy does not address the immediate needs of the community to prevent displacement or further displacement.

I appreciate your consideration.

All the best,

Cecilia Taylor  
Councilmember  
City Hall - 2nd Floor  
701 Laurel St.  
tel 650-589-5073  
menlopark.org



## STAFF REPORT

### City Council

Meeting Date:

8/17/2021

Staff Report Number:

21-157-CC

Informational Item:

City Council agenda topics: August to September 2021

### Recommendation

The purpose of this informational item is to provide the City Council and members of the public access to the anticipated agenda items that will be presented to the City Council. The mayor and city manager set the City Council agenda so there is no action required of the City Council as a result of this informational item.

### Policy Issues

In accordance with the City Council procedures manual, the mayor and city manager set the agenda for City Council meetings.

### Analysis

In an effort to provide greater access to the City Council's future agenda items, staff has compiled a listing of anticipated agenda items, Attachment A, through September 14, 2021. The topics are arranged by department to help identify the work group most impacted by the agenda item.

Specific dates are not provided in the attachment due to a number of factors that influence the City Council agenda preparation process. In their agenda management, the mayor and city manager strive to compile an agenda that is most responsive to the City Council's adopted priorities and work plan while also balancing the business needs of the organization. Certain agenda items, such as appeals or State mandated reporting, must be scheduled by a certain date to ensure compliance. In addition, the meeting agendas are managed to allow the greatest opportunity for public input while also allowing the meeting to conclude around 11 p.m. Every effort is made to avoid scheduling two matters that may be contentious to allow the City Council sufficient time to fully discuss the matter before the City Council.

### Public Notice

Public notification was achieved by posting the agenda, with the agenda items being listed, at least 72 hours prior to the meeting.

### Attachments

A. City Council agenda topics: August to September 2021

Report prepared by:

Judi A. Herren, City Clerk

**Tentative City Council Agenda**

#	Title	Department	Item type	City Council action
1	Authorization for blanket purchase orders and multi-year agreements	ASD	Consent	Adopt resolution
2	Financial advisory services and bond counsel services for a Measure T bond issuance	ASD	Regular	Contract award or amend
3	Ratify successor MOU - POA	ASD	Regular	Adopt resolution
4	710 Willow Road appeal of use permit denial for alcohol sales	CDD	Public Hearing	Decide
5	BMR fund recommendation - MidPen Pierce Rd. housing	CDD	Regular	Adopt resolution
6	Housing Element Status Update	CDD	Informational	No action
7	Menlo Uptown major subdivision map (Appeals + map hearing)	CDD	Public Hearing	Adopt resolution
8	Samaritan House agreement amendment (ARPA \$)	CDD	Consent	Approve
9	2021 priorities and work plan quarterly report as of June 30	CMO	Consent	Receive and file
10	Approve EQC two year work plan	CMO	Consent	Approve
11	CAP #1 - existing building electrification cost effectiveness study session	CMO	Study Session	Direction to staff
12	Dissolve Housing Element subcommittee	CMO	Consent	Decide
13	Menlo Park Sister Cities Association funding request (presentation?)	CMO	Consent	Approve
14	Quarterly personnel update (Jul-Sep)	CMO	Consent	Receive and file
15	Redistricting: independent commission	CMO	Regular	Direction to staff
16	SB1383 study session	CMO	Study Session	No action
17	Library Commission work plan	LCS	Presentation	No action
18	Parks and Recreation Commission work plan	LCS	Presentation	No action
19	Rescind the portion of Emergency Order No. 2 related to Arrillaga Family Gymnasium	LCS	Consent	Adopt resolution
20	Gymnastics reactivation analysis	LCS	Study Session	Direction to staff
21	2021 Water Main Replacement Haven Ave. Fire Flow Improvements	PW	Consent	
22	Complete Streets Commission work plan approval	PW	Regular	Approve
23	FEMA BRIC grant study session	PW	Study Session	Direction to staff
24	Funding agreement for 1540 El Camino Real improvements	PW	Consent	Approve
25	Funding agreement for Chilco Street improvements	PW	Consent	Approve
26	Permanent installation of Belle Haven Traffic Calming Plan improvements	PW	Regular	Approve
27	Transportation Management Association feasibility study approval	PW	Regular	Approve
28	West Bay Sanitary - MOU for Recycled Water	PW	Regular	Approve
29	Menlo Portal - PUE abandonment	PW, CDD	Pubic Hearing	Approve
30	Records destruction	VARIOUS	Consent	Adopt resolution





**STAFF REPORT**

**City Council Meeting Date:** 8/17/2021  
**Staff Report Number:** 21-158-CC

**Informational Item:** Update on the Menlo Park local hazard mitigation plan annex to the San Mateo County hazard mitigation plan

**Recommendation**

This is an informational item and does not require City Council action. The public review draft of the San Mateo County HAZARD MITIGATION PLAN, including the Menlo Park local hazard mitigation plan annex, is now available (Attachment A.)

**Policy Issues**

According to Menlo Park Municipal Code Section 2.44.050(5), the City’s director of emergency services (e.g., city manager) is empowered to request, contract for, receive, and implement state and federal aid for all types relating to disaster preparedness and relief.

**Background**

The local hazard mitigation plan (LHMP) outlines strategies that would reduce risk or eliminate long-term risk to life and property from a hazard event. It identifies the hazards that could affect the community, sets clear goals and actions, and follows through with an effective mitigation strategy. Mitigation could also protect critical community facilities, reduce exposure to liability, and minimize post-disaster community disruption.

The LHMP outlines various strategies that the jurisdiction currently implements and also presents future opportunities to reduce vulnerability and exposure to future events. The goals are, but not limited to:

- Protect the health and safety of the community;
- Promote hazard mitigation;
- Integrate climate change strategies to increase resiliency from the impact of climate change; and
- Improve community emergency management capability.

Adopting it allows jurisdictions to be eligible for various types of pre- and post-disaster grants from the Federal Emergency Management Agency (FEMA) and California Governor’s Office of Emergency Services (Cal OES), such as the \$5 million hazard mitigation grant program for the Chrysler Pump Station reconstruction and the \$50 million Building Resilient Infrastructure and Communities (BRIC) grant pending FEMA review for constructing a portion of the SAFER Bay sea level rise protection project.

To comply with the federal mandates in the Disaster Mitigation Act of 2000 (Public Law 106-390) and Menlo Park Municipal Code Section 2.44.050(5), the LHMP typically updates every five years. Menlo Park City Council last adopted Resolution No. 6339 (Attachment B) August 30, 2016 to approve an update to the Menlo Park local hazard mitigation plan annex to the San Mateo County hazard mitigation plan.

## Analysis

The San Mateo County Department of Emergency Management formed a partnership with 37 County of San Mateo jurisdictions to update its 2016 multijurisdictional local hazard mitigation plan (LHMP.) The County Office hired a consultant to help facilitate the planning process and the County typically hosts monthly educational and training webinars for jurisdictions to attend. Each jurisdiction is required to prepare an annex to the multijurisdictional LHMP, with mitigation strategies specific to the needs of that jurisdiction.

The multijurisdictional LHMP is a living document, such that as awareness of additional hazards develop and new strategies and projects are conceived to offset or prevent loss due to natural hazards, it may be evaluated and revised on an annual basis during the 5-year plan timeframe. The draft plan contains two volumes:

- Volume 1: An overview of the planning process, risk assessment, goals and objectives, countywide actions and plan maintenance strategy; and
- Volume 2: Background information of each jurisdiction-specific mitigation action plan.

Menlo Park opted to plan its annex through a social equity perspective to address mitigation efforts for vulnerable communities. Since March, residents were asked to contribute by sharing local knowledge of their individual area's vulnerability to natural hazards based on past occurrences. Public involvement has been solicited through a multimedia campaign that included public meetings, web-based information, questionnaires and progress updates. While the County conducted outreach, the City promoted the multijurisdictional LHMP surveys and public meetings on social media, such as Twitter, Facebook and Nextdoor, and on the weekly digest newsletter. One of the outreach meetings focused on the North Fair Oaks and Belle Haven neighborhoods and the City of East Palo Alto. Approximately 85 residents from the 94025 ZIP code responded to the two outreach surveys and 10 residents attended the first public workshop.

The Menlo Park annex (Attachment C) consists of three sections to:

- Showcase the City of Menlo Park profile, analyze the current trends, and review the previous LHMP;
- Examine existing capabilities for implementing hazard mitigation strategies; and
- Analyze risk assessment and identify mitigation plan objectives by type of hazards.

The Menlo Park annex also focuses on actions to mitigate flood, earthquake and climate change, which are categorized as "high" risk hazards within the city boundaries. City staff from Public Works, Community Development, Informational Technology, Sustainability, and Menlo Park Fire Protection District revised the 2016 LHMP annex and identified several new opportunities to mitigate any potential losses from the effects of natural disasters. The Menlo Park Fire Protection District has prepared its own annex as one of the 37 jurisdictions identified above.

### Next steps

Table 1 outlines the timeline to implement the multijurisdictional LHMP. The draft Menlo Park annex is posted online (Attachment C) and members of the public may review it and submit their comments by Monday, August 23 by emailing comments to [MJLHMP@smcgov.org](mailto:MJLHMP@smcgov.org) or submitting an online form at the link in Attachment D.

Table 1: Multijurisdictional local mitigation plan timeline	
Date	Tasks
August 5	• Draft multijurisdictional LHMP posted online
August 12	• Second public workshop
August 23	• Last day of public comments on multijurisdictional LHMP
September – November	• The County submits draft multijurisdictional LHMP to Cal OES and FEMA for review • The County receives submission results from Cal OES and FEMA
Tent. November	• Menlo Park City Council (and all local agencies) adopt resolution approving their annexes
Tent. December	• County of San Mateo Board of Supervisors adopt resolution approving the multijurisdictional LHMP

Once the hazard mitigation plan has been approved by Cal OES and FEMA and adopted by all of the jurisdictional partners, the partnership will collectively and individually become eligible to apply for hazard mitigation project funding from the suite of grant programs under FEMA’s Hazard Mitigation Assistance (HMA) program. The multijurisdictional LHMP needs to be adopted by the County of San Mateo Board of Supervisors as the final step in the process.

**Impact on City Resources**

City staff anticipates returning to City Council in November to adopt a resolution to approve an update to the Menlo Park LHMP annex to the multijurisdictional LHMP. Adopting the multijurisdictional LHMP would qualify the City to apply for pre- and post-disaster grants from FEMA. The City of Menlo Park has currently received a grant for \$5 million for the Chrysler Pump Station improvements through FEMA’s hazard mitigation grant program; and the City’s FEMA BRIC grant application for \$50 million is under further review for the SAFER Bay sea level rise protection construction project. The City would forfeit these funds if an updated LHMP is not adopted by the City Council later this year.

**Environmental Review**

This action is not a project within the meaning of the California Environmental Quality Act (CEQA). Guidelines §§ 15378 and 15061(b)(3) as it will not result in any direct or indirect physical change in the environment.

**Public Notice**

Public notification was achieved by posting the agenda, with the agenda items being listed, at least 72 hours prior to the meeting.

**Attachments**

- A. Hyperlink – draft multijurisdictional LHMP: [cmo.smcgov.org/2021-multijurisdictional-lhmp](http://cmo.smcgov.org/2021-multijurisdictional-lhmp)
- B. Resolution No. 6339
- C. Menlo Park annex excerpt
- D. Email – [MJLHMP@smcgov.org](mailto:MJLHMP@smcgov.org) and public comment online hyperlink: [surveymonkey.com/r/SMC\\_MJLHMP\\_PC](https://surveymonkey.com/r/SMC_MJLHMP_PC)

Staff Report #: 21-158-CC

Report prepared by:  
Joanna Chen, Management Analyst

Report reviewed by:  
Nicole Nagaya, Public Works Director

## RESOLUTION NO. 6339

**RESOLUTION OF THE CITY COUNCIL OF THE CITY OF MENLO  
PARK AUTHORIZING THE ADOPTION OF THE SAN MATEO COUNTY  
LOCAL HAZARD MITIGATION PLAN UPDATE AND ANNEX**

WHEREAS, all of San Mateo County has exposure to natural hazards that increase the risk to life, property, environment and the County's economy; and

WHEREAS; pro-active mitigation of known hazards before a disaster event can reduce or eliminate long-term risk to life and property; and

WHEREAS, The Disaster Mitigation Act of 2000 (Public Law 106-390) established new requirements for pre- and post-disaster hazard mitigation programs; and

WHEREAS; a coalition of San Mateo County, Cities, Towns and Special Districts with like planning objectives has been formed to pool resources and create consistent mitigation strategies within the San Mateo County planning area; and

WHEREAS, the coalition has completed a planning process that engages the public, assesses the risk and vulnerability to the impacts of natural hazards, develops a mitigation strategy consistent with a set of uniform goals and objectives, and creates a plan for implementing, evaluating and revising this strategy.

NOW, THEREFORE, BE IT RESOLVED that the City of Menlo Park:

- 1) Adopts in its entirety, Volume I and the introduction, chapter 11 the City of Menlo Park jurisdictional annex, and the appendices of Volume 1 of the San Mateo County Hazard Mitigation Plan (HMP).
- 2) Will use the adopted and approved portions of the HMP to guide pre- and post-disaster mitigation of the hazards identified.
- 3) Will coordinate the strategies identified in the HMP with other planning programs and mechanisms under its jurisdictional authority.
- 4) Will continue its support of the Steering Committee and continue to participate in the Planning Partnership as described by the HMP.
- 5) Will help to promote and support the mitigation successes of all HMP Planning Partners.

I, Pamela Aguilar, City Clerk of the City of Menlo Park, do hereby certify that the above and foregoing Resolution was duly and regularly passed and adopted at a meeting by said Council on the thirtieth day of August, 2016, by the following votes:

AYES: Carlton, Cline, Keith, Ohtaki

NOES: None

ABSENT: Mueller

ABSTAIN: None

IN WITNESS WHEREOF, I have hereunto set my hand and affixed the Official Seal of said City on this thirtieth day of August, 2016.



Pamela Aguilar, CMC  
City Clerk



# 2021 Multijurisdictional Local Hazard Mitigation Plan

Volume 2b—Planning Partner Annexes  
*Municipalities: East Palo Alto – Pacifica*

Public Review Draft



August | 2021



TETRA TECH

Page N-2.6



# 2021 Multijurisdictional Local Hazard Mitigation Plan

August 2021

## PREPARED FOR

---

### County of San Mateo Department of Emergency Management

501 Winslow  
Redwood City, CA 94063

## PREPARED BY

---

### Tetra Tech

1999 Harrison St., Suite 500  
Oakland, CA 94612  
510-302-6300 | tetrattech.com

## NOTE ABOUT VOLUME 2

Volume 2 of the *San Mateo County 2021 Multijurisdictional Local Hazard Mitigation Plan*, which presents annexes for all planning partners who participated in this plan, has been divided into multiple parts to maintain manageable file sizes.

Parts 2a through 2d include the complete table of contents and the introduction, along with annexes for the following partners:

- Volume 2a—San Mateo County and municipalities alphabetically from Atherton through Daly City
- Volume 2b—Municipalities alphabetically from East Palo Alto through Pacifica
- Volume 2c—Municipalities alphabetically from Portola Valley through Woodside
- Volume 2d—Special-purpose districts

Part 2e includes the complete table of contents and the Volume 2 appendices.

Tetra Tech Project #103s7389

\\tts121fs1\Data\EMCR\_Projects\California\SanMateoCounty\HMP\_2021\_103S7389\Plan Development\Plan Documents\2021-08\_PublicReviewDraft\2021-08-05\_SanMateoHMP\_Vol2\_PublicReviewDraft.docx





# 12. CITY OF MENLO PARK

---

## 12.1 LOCAL HAZARD MITIGATION PLANNING TEAM

### Primary Point of Contact

Brian Henry  
Assistant Public Works Director  
701 Laurel Avenue  
Menlo Park, CA 94025  
650-330-6799  
E-mail: bphenry@menlopark.org

### Alternate Point of Contact

Chuck Andrews  
Assistant Community Development Director  
701 Laurel Avenue  
Menlo Park, CA 94025  
650-330-6757  
E-mail: chandrews@menlopark.org

This annex was developed by the local hazard mitigation planning team, whose members are listed in Table 12-1.

**Table 12-1. Local Mitigation Planning Team Members**

Name	Title
Chuck Andrews	Assistant Community Development Director
Calvin Chan	Senior Planner
Joanna Chen	Management Analyst I
Brian Henry	Assistant Public Works Director
Chris Lamm	Assistant Public Works Director
Scott Mackdanz	Police Dept. Administrative Sergeant
Justin Murphy	Deputy City Manager
Nicole Nagaya	Public Works Director
Ryan Zollicoffer	Fire District Disaster Response Manager

## 12.2 JURISDICTION PROFILE

### 12.2.1 Location and Features

Menlo Park is a city of beautiful, tree-lined neighborhoods and active commercial districts. Located conveniently between the major metropolitan areas of San Francisco and San Jose, Menlo Park is home to over 35,000 residents in its approximately 19 square miles. The stunning natural surroundings of the city afford views of the San Francisco Bay to the east and the Pacific Coast Range to the west.

The city's proximity to Stanford University and Menlo College provide a multitude of academic, cultural, and athletic event opportunities. Located in the heart of Menlo Park is a downtown featuring unique and upscale shops and restaurants. Known worldwide as the "Capital of Venture Capital," Menlo Park is well situated to benefit

from and shape new technologies originating from Silicon Valley. The city is home to such notable employers as SRI, Facebook, and Pacific Biosciences.

The City of Menlo Park climate is mild during the summer when temperatures tend to be in the 60's and cool during the winter when temperatures tend to be in the 50's. The warmest month of the year is July with an average maximum temperature of 78 degrees Fahrenheit, while the coldest month of the year is December with an average minimum temperature of 39 degrees Fahrenheit. On average, there are 265 sunny days per year with 56 days of measurable precipitation.

## **1.2.2 History**

In 1854, Menlo Park received its official name when two Irishmen, Dennis J. Oliver and D. C. McGlynn, whose wives were sisters, purchased 1,700 acres (some sources say it was 640 acres) bordering County Road, now El Camino Real, and built two houses with a common entrance.

Across the drive, they erected a huge wooden gate with tall arches on which the name of their estate was printed in foot-high letters: "MENLO PARK," with the date, August 1854, underneath it. When the railroad came through in 1863, this station had no name, it was just the end of the line, but it needed a designation. During a discussion about the choice of a name, a railroad official looked over at the gates and decided that "MENLO PARK" would be appropriate, and so the name was officially adopted. This station is now California State Landmark No. 955, the oldest California station in continuous operation.

On March 23, 1874, Menlo Park became the second incorporated city in San Mateo County, although only for a short time. The purpose was to provide a quick way to raise money for road repairs.

This incorporation, which included Fair Oaks (later Atherton) and Ravenswood (later East Palo Alto) lasted only until 1876. Little occurred to change the rural flavor of the community until the first World War when, almost overnight, Menlo Park was populated by 43,000 soldiers in training at Camp Fremont, on land which extended from Valparaiso Avenue to San Francisquito Creek, and El Camino Real to the Alameda de las Pulgas, with the Base Hospital and other facilities on Willow Road where the Veterans Administration Medical Center now stands.

Following the war, enough service center activity remained to prompt an effort to reincorporate Menlo Park in 1923 with much the same boundaries as the earlier town. Incorporation planning involving Menlo Park and Atherton culminated in a dramatic race to the County Courthouse to file differing plans. Atherton representatives arrived only minutes before those from Menlo Park who had wished to include Atherton in their plans. Final incorporation of Menlo Park took place in November 1927.

## **12.2.2 Governing Body Format**

Menlo Park is a general law city under the State of California and operates under the Council-Manager form of government. The City Council is the city's governing body for the City of Menlo Park. In general, municipal elections, its members are elected from five districts to four-year overlapping terms. The Mayor and Mayor Pro Tempore each serve one-year terms and are selected annually by the City Council at its first regular meeting in December. The Mayor, who represents the City of Menlo Park at ceremonial and public functions, also serves as the presiding officer of the City Council.

The City Council appoints the City Manager and the City Attorney. The City is organized into operating departments including Administrative Services, City Manager’s Office, Community Development, Library and Community Services, Police, and Public Works. The City of Menlo Park assumes responsibility for the adoption of this plan; the Community Development, Public Works, and Police Departments will oversee its implementation.

## 12.3 CURRENT TRENDS

### 12.3.1 Population

According to the California Department of Finance, the population of Menlo Park as of January 2020 was 35,254 persons. Since 2016, the population has grown at an average annual rate of 0.99 percent.

### 12.3.2 Development

Table 12-2 summarizes development trends in the performance period since the preparation of the previous hazard mitigation plan, as well as expected future development trends.

**Table 12-2. Recent and Expected Future Development Trends**

Criterion	Response																														
<p>Has your jurisdiction annexed any land since the preparation of the previous hazard mitigation plan? <i>If yes, give the estimated area annexed and estimated number of parcels or structures.</i></p>	No																														
<p>Is your jurisdiction expected to annex any areas during the performance period of this plan? <i>If yes, describe land areas and dominant uses. If yes, who currently has permitting authority over these areas?</i></p>	<p>None</p> <p>The City has had interest from the West Menlo Park triangle area to be annexed by the City. The area represents approximately 14 acres of residential property. The City does not believe the area has been identified as any type of hazard risk, but additional investigations would be required prior to annexation. Reference Staff Report 11/5/2019 (19-230-CC).</p>																														
<p>Are any areas targeted for development or major redevelopment in the next five years? <i>If yes, briefly describe, including whether any of the areas are in known hazard risk areas</i></p>	<p>Yes</p> <p>The City has ongoing development in both the Bayfront and Downtown Areas of Menlo Park. Projects in the Bayfront Area must comply with Special Hazard Flood Area construction requirements as required by City ordinance. Development Projects can be found at: <a href="https://www.menlopark.org/projects">https://www.menlopark.org/projects</a>.</p> <p>The City is in the process of updating the General Plan Housing Element for the planning period of 2023-2031, which is expected to identify additional areas for residential development.</p>																														
<p>How many permits for new construction were issued in your jurisdiction since the preparation of the previous hazard mitigation plan?</p>	<table border="1"> <thead> <tr> <th></th> <th>2016</th> <th>2017</th> <th>2018</th> <th>2019</th> <th>2020</th> </tr> </thead> <tbody> <tr> <td>Single-Family</td> <td>19</td> <td>32</td> <td>44</td> <td>54</td> <td>50</td> </tr> <tr> <td>Multi-Family</td> <td>1</td> <td>10</td> <td>1</td> <td>3</td> <td>3</td> </tr> <tr> <td>Other (commercial, mixed use, etc.)</td> <td>1</td> <td>5</td> <td>7</td> <td>8</td> <td>7</td> </tr> <tr> <td><b>Total</b></td> <td><b>21</b></td> <td><b>47</b></td> <td><b>52</b></td> <td><b>65</b></td> <td><b>60</b></td> </tr> </tbody> </table>		2016	2017	2018	2019	2020	Single-Family	19	32	44	54	50	Multi-Family	1	10	1	3	3	Other (commercial, mixed use, etc.)	1	5	7	8	7	<b>Total</b>	<b>21</b>	<b>47</b>	<b>52</b>	<b>65</b>	<b>60</b>
	2016	2017	2018	2019	2020																										
Single-Family	19	32	44	54	50																										
Multi-Family	1	10	1	3	3																										
Other (commercial, mixed use, etc.)	1	5	7	8	7																										
<b>Total</b>	<b>21</b>	<b>47</b>	<b>52</b>	<b>65</b>	<b>60</b>																										

Criterion	Response
Provide the number of new-construction permits for each hazard area or provide a qualitative description of where development has occurred.	<ul style="list-style-type: none"> <li>• Special Flood Hazard Areas: 74</li> <li>• Landslide: 0</li> <li>• High Liquefaction Areas: 162</li> <li>• Tsunami Inundation Area: 0</li> <li>• Wildfire Risk Areas: 0</li> </ul> Comments: There are 56 new-construction permits in both the Special Flood Hazard Area and High Liquefaction Area
Describe the level of buildout in the jurisdiction, based on your jurisdiction’s buildable lands inventory. If no such inventory exists, provide a qualitative description.	Not applicable – There is no more land to be developed in non-hazard areas.

## 12.4 CAPABILITY ASSESSMENT

This section describes an assessment of existing capabilities for implementing hazard mitigation strategies. The introduction at the beginning of this volume of the hazard mitigation plan describes the components included in the capability assessment and their significance for hazard mitigation planning.

Findings of the capability assessment were reviewed to identify opportunities to expand, initiate or integrate capabilities to further hazard mitigation goals and objectives. Where such opportunities were identified and determined to be feasible, they are included in the action plan. The “Analysis of Mitigation Actions” table in this annex identifies these as community capacity building mitigation actions. The findings of the assessment are presented as follows:

- An assessment of planning and regulatory capabilities is presented in Table 12-3.
- Development and permitting capabilities are presented in Table 12-4.
- An assessment of fiscal capabilities is presented in Table 12-5.
- An assessment of administrative and technical capabilities is presented in Table 12-6.
- An assessment of education and outreach capabilities is presented in Table 12-7.
- Information on National Flood Insurance Program (NFIP) compliance is presented in Table 12-8.
- Classifications under various community mitigation programs are presented in Table 12-9.
- The community’s adaptive capacity for the impacts of climate change is presented in Table 12-10.

**Table 12-3. Planning and Regulatory Capability**

	Local Authority	Other Jurisdiction Authority	State Mandated	Integration Opportunity?
<b>Codes, Ordinances, &amp; Requirements</b>				
<b>Building Code</b>	Yes	No	Yes	No
<b>Comment:</b> Menlo Park Municipal Code, Title 12, CA Building Code 2019. The Community Development, Building and Planning Divisions, adopted the code on 12/17/2019 and it became effective on 1/1/2020.				
<b>Zoning Code</b>	Yes	No	No	Yes
<b>Comment:</b> Menlo Park Municipal Code, Title 16. The Community Development, Planning Division, implements this code. The Zoning Ordinance was adopted in November 2016.				
<b>Subdivisions</b>	Yes	No	No	No
<b>Comment:</b> Menlo Park Municipal Code, Title 15, adopted in 1977. The Community Development, Planning Division, and the Public Works, Engineering Division, implement this code.				
<b>Stormwater Management</b>	Yes	Yes	Yes	Yes
<b>Comment:</b> Menlo Park Municipal Code, Title 7.42, adopted in 1994. Stormwater Management Program complies with the California Regional Water Quality Control Board San Francisco Bay Region Municipal Regional Stormwater NPDES Permit. Updated permit requirements were last issued in November 2015, and further updates are currently being considered and are expected to be adopted in late 2021 or early 2022. The Public Works, Engineering & Maintenance Divisions, and the City Manager's Office, Sustainability Programs, implement this permit.				
<b>Post-Disaster Recovery</b>	Yes	No	No	Yes
<b>Comment:</b> The City does not have a specific Municipal Code or ordinance for Post Disaster Recovery. The City activates the emergency operations center for oversight and tasks related to recovery actions and activities working alongside partner agencies. The City Emergency Operation Plan addresses establishing a Recovery Task Force to commence planning for transition to long term recovery. The City is also working with the County on turning the Countywide Debris Management Plan into a stand-alone jurisdictional annex. The City will align its recovery actions with the National and State Disaster Recovery Framework Plan.				
Menlo Park Municipal Code Chapter 2.44, Emergency Services: <a href="https://www.codepublishing.com/CA/MenloPark#!/html/MenloPark02/MenloPark0244.html">https://www.codepublishing.com/CA/MenloPark#!/html/MenloPark02/MenloPark0244.html</a>				
<b>Real Estate Disclosure</b>	No	No	Yes	No
<b>Comment:</b> California Civil Code Section 1103 <a href="https://leginfo.ca.gov/faces/codes_displaySection.xhtml?sectionNum=1103.&amp;lawCode=CIV">https://leginfo.ca.gov/faces/codes_displaySection.xhtml?sectionNum=1103.&amp;lawCode=CIV</a>				
<b>Growth Management</b>	Yes	No	No	Yes
<b>Comment:</b> Between 2015 and 2020, Menlo Park saw a population increase of 5.4 percent, compared to a 1.5 percent increase countywide. During this time period, the number of households in Menlo Park increased by 5.6 percent, compared to a 1.5 percent increase countywide. Average persons per household remained relatively the same for both Menlo Park and countywide, with Menlo Park having 2.64 persons per household and 2.88 persons per household countywide in 2020 (CA Department of Finance, E-5 Report).				
According to the Association of Bay Area Governments' (ABAG) Plan Bay Area projections for the nine counties that comprise the Bay Area region, between 2015 and 2020, total population increased 4.3 percent and total households increased 4.4 percent. Average persons per household remained the same during this time period, with 2.69 persons per household (ABAG Projections 2040).				
The city's development pipeline includes approximately 3,878 residential units, 4.9 million square feet of office space, 317,000 square feet of retail space, 40,000 square feet of school space, and 642 hotel rooms (December 2020).				
<b>Site Plan Review</b>	Yes	No	No	No
<b>Comment:</b> The Building Division of Community Development reviews all site plans for conformance to the Menlo Park Municipal Code, Title 12. The Planning Division of Community Development reviews all site plans for conformance to the Menlo Park Municipal Code, Title 15, and Title 16. The Engineering Division of the Public Works Department reviews site plans for all projects for conformance to the Menlo Park Municipal Code, Title 7.				

	Local Authority	Other Jurisdiction Authority	State Mandated	Integration Opportunity?
<b>Environmental Protection</b>	Yes	No	No	Yes
<p><b>Comment:</b> The City has several ordinances and policies related to environmental protection:</p> <ul style="list-style-type: none"> <li>In 2015, the Integrated Pest Management Policy was updated. Currently, all City parks are herbicide- and pesticide-free.</li> <li>In January 2020, the City adopted reach codes for new construction to reduce greenhouse gas emissions from the building sector and to encourage the use of renewable and clean energy. Menlo Park residents receive energy from Peninsula Clean Energy, which provides a minimum of 50% renewable energy and 90% greenhouse gas (carbon) free electricity at a cost slightly less than PG&amp;E. Electrifying buildings would maximize the community’s renewable power available and reduce GHG emissions by slowly phasing out the use of natural gas.</li> <li>The City’s Climate Action Plan was adopted in July 2020 and several of its goals are related to environmental protection. Two of the goals are related to electric vehicles: to promote the purchase of electric vehicles and increase EV charging stations in multi-family and commercial buildings; and to reduce greenhouse gas emissions and improve air quality. The City adopted a Sustainable Vehicle Fleet Policy to increase the number of zero-emission City fleet vehicles. Another goal is to eliminate the use of natural gas from municipal operations. As a pilot program in 2021, Public Works maintenance staff is in the process of converting gas-powered maintenance equipment to electric to reduce noise pollution and greenhouse gas emissions.</li> </ul>				
<b>Flood Damage Prevention</b>	Yes	No	No	Yes
<p><b>Comment:</b> Menlo Park Municipal Code, Title 12.42, adopted in 1988 and amended in 2016. The Public Works Department, Engineering Division, implements this Code section.</p>				
<b>Emergency Management</b>	Yes	No	Yes	Yes
<p><b>Comment:</b> Menlo Park Municipal Code, Chapter 2.44 Emergency Services  <a href="https://www.codepublishing.com/CA/MenloPark/html/MenloPark02/MenloPark0244.html">https://www.codepublishing.com/CA/MenloPark/html/MenloPark02/MenloPark0244.html</a></p>				
<b>Climate Change</b>	Yes	Yes	Yes	Yes
<p><b>Comment:</b> The 2030 Climate Action Plan (CAP) was adopted in July 2020. One of the CAP goals and City Council 2021 work plan priority projects is to develop a climate adaption plan to address sea level rise and flooding. Staff plans to:</p> <ul style="list-style-type: none"> <li>Update the Safety Element in Menlo Park’s General Plan to bring it into compliance with recent changes in General Plan law, including SB 379</li> <li>Await notification on the SAFER Bay grant application from the FEMA Building Resilient Infrastructure and Communities program</li> <li>Continue progress on identifying funding and partnership opportunities for implementing SAFER Bay; and</li> <li>Continue to participate in and monitor with San Mateo County Flood and Sea Level Rise District.</li> </ul>				
<b>Planning Documents</b>				
<b>General Plan</b>	Yes	No	Yes	Yes
<p><b>Is the plan compliant with Assembly Bill 2140?</b> Yes</p> <p><b>Comment:</b> The City’s General Plan can be accessed at: <a href="https://www.menlopark.org/146/General-Plan">https://www.menlopark.org/146/General-Plan</a>. The Open Space/Conservation, Noise, and Safety Elements (adopted May 21, 2013) address safety and emergency preparedness, specifically Section IV (Safety Goals, Policies, and Implementing Programs) and Section VII (Safety Background). The Plan “provides policies and standards for the type, location, intensity and design of development in areas of potential hazards” (Safety Goal S1).</p> <p>Other General Plan Elements include: Land Use and Circulation Elements (adopted November 29, 2016) and the 2015-2023 Housing Element (adopted April 1, 2014). The City is in the process of updating the Housing Element for the period of 2023-2031 and will concurrently prepare updates to the Safety Element and the preparation of a new Environmental Justice Element.</p>				
<b>Capital Improvement Plan</b>	Yes	No	No	Yes
<p><b>How often is the plan updated?</b> Annually</p> <p><b>Comment:</b> The Capital Improvement Plan involves the implementation of infrastructure projects, such as the upgrade of storm water pumping facilities and the construction of emergency wells, to improve the City’s resiliency to hazards. Planning is made on a 5 year basis, with annual updates.</p>				

	Local Authority	Other Jurisdiction Authority	State Mandated	Integration Opportunity?
<b>Disaster Debris Management Plan</b>	Yes	No	No	Yes
<b>Comment:</b> The City is also working with the County on turning their Countywide Debris Management Plan into a stand-alone debris management annex for Menlo Park. According to the City's franchise agreement, Recology may provide emergency services, such as assistance handling, salvaging, processing, composting, recycling materials, or disposing solid waste after a major accident, disruption, or natural calamity.				
<b>Floodplain or Watershed Plan</b>	No	Yes	No	No
<b>Comment:</b> The City maintains FEMA floodplain maps and provides information related to flood zones to the public when requested.				
<b>Stormwater Plan</b>	Yes	Yes	No	Yes
<b>Comment:</b> The engineering division is in the process of updating its 2003 stormwater master plan. The plan, when completed, will model the entire City storm drain network and identify areas vulnerable to localized flooding and identify capital projects to mitigate the flooding in these areas. The plan also identifies measures to comply with State mandated requirements under the NPDES permitting requirements.				
<b>Urban Water Management Plan</b>	Yes	Yes	Yes	No
<b>Comment:</b> The City will be updating its 2015 UWMP with a 2020 UWMP by July 1, 2021. The plan additionally identifies water conservation measures that will be taken in the event of a drought with 'stages' identified at 10%, 20%, 30%, 40%, 50%, and greater than 50% reduction.				
<b>Habitat Conservation Plan</b>	No	No	No	No
<b>Comment:</b> While the City does not have a Habitat Conservation Plan, the City amended its Heritage Tree Ordinance in 2019 and implemented it on July 1, 2020, to help preserve the Menlo Park's urban canopy. In 2021, Menlo Park has been recognized as a Tree City USA for 21 years and as a member of the Arbor Day Foundation's "Growth" group for 5 years. The City also partners with Canopy, a nonprofit organization, to help plant street trees around the neighborhoods to provide shade, habitat for the wildlife, and add beautification in the area.				
<p>As part of the South Bay Salt Pond Restoration project, the Ravenswood Ponds Levee Maintenance and Habitat Enhancement project is currently underway and will enhance the habitat environment at the Refuge's Ravenswood Ponds, on lands south of Bedwell Bayfront Park.</p> <p>The Open Space/Conservation Element of the General Plan combines the Open Space and Conservation Elements required by State law. Open Space issues include policies and programs to maintain, expand and improve Menlo Park's open space and recreation areas (including parks) while Conservation institutes policies and programs to conserve natural resources. Preservation of scenic, habitat, and recreational resources in Menlo Park is key to retaining the city's special sense of place. Among its many natural features, Menlo Park is known for its high-quality active and passive recreation areas, including Bedwell Bayfront Park, which is a regional draw. Menlo Park highly values ongoing restoration and conservation efforts in the Baylands, which provide habitat for a wide variety of plants and animals in the Don Edwards National Wildlife Refuge.</p> <p>The Zoning Code (Municipal Code Title 16) includes an Open Space and Conservation District (Chapter 16.48). The purpose and intent of this district is:</p> <ul style="list-style-type: none"> <li>• To protect the public health, safety and welfare <ul style="list-style-type: none"> <li>• To protect and preserve open space land as a limited and valuable resource</li> </ul> </li> <li>• To assure its continued availability for the following: As agricultural land, scenic land, recreation land, conservation, or natural resource land; for the containment of urban sprawl and the structuring of urban development, and for the retention of land in its natural or near natural state to protect life and property in the community from the hazards of fire, flood, and seismic activity; and</li> <li>• To coordinate with and carry out federal, state, regional, county and city open space plans.</li> </ul>				
<b>Economic Development Plan</b>	Yes	No	No	No
<b>Comment:</b> The City's Economic Development Plan (adopted July 2015) can be accessed at: <a href="https://www.menlopark.org/1123/Economic-development-plan-and-goals">https://www.menlopark.org/1123/Economic-development-plan-and-goals</a> . The Plan consists of three main elements: a Comparative Economic Advantages Study (CEAS), the Goals, and a series of Strategic Policy Recommendations towards implementing the Goals. The CEAS lays the foundation for the Economic Development Plan by outlining Menlo Park's economic advantages, opportunities, and challenges in relation to other similar cities in the Silicon Valley region and the broader San Francisco Bay Area.				



	Local Authority	Other Jurisdiction Authority	State Mandated	Integration Opportunity?
<b>Shoreline Management Plan</b>	Yes	Yes	No	Yes
<b>Comment:</b> The City of Menlo Park shoreline is subject to San Francisco Bay Conservation & Development Commission regulations.				
<p>The City does not have a Shoreline Management Plan; however, the City has several ongoing projects to help manage the risks associated with the shoreline along the Bayfront Canal-Atherton Channel and the former salt ponds.</p> <ul style="list-style-type: none"> <li>The SAFER Bay project objective is to protect against 100-year flood, remove properties from FEMA floodplain, sustain marsh habitat, and facilitate marsh restoration. The plan identifies protection measures for 3-feet of sea level rise.</li> <li>The FEMA Building Resilience Infrastructure and Communities (BRIC) grant project would provide levee improvements along the majority of Menlo Park’s shoreline. The grant awards up to \$50 million, but the project cost estimate is \$66 million, including matching funds from private partners. This would help provide flood protection and sea level rise resiliency while preserving habitat restoration of over 550 acres of former salt ponds. If awarded, the estimated project timeline is five years, including design and construction.</li> <li>The Bayfront Canal and Atherton Channel Flood Management and Restoration project is anticipated to begin construction this year (2021) and involves installing underground pipes connecting Bayfront Canal to the Ravenswood Ponds to reduce the impact of flooding.</li> <li>One of City Council’s 2021 work plan project is to develop a climate adaption plan.</li> </ul>				
<b>Community Wildfire Protection Plan</b>	No	No	No	No
<b>Comment:</b> The Fire District provides fire suppression and fire protection services to the City of Menlo Park. The California Department of Forestry and Fire Protection does not acknowledge the City of Menlo Park as being in an area known to be considered as a “wildland urban interface” environment. The Fire District boundaries do not warrant a Community Wildfire Protection Plan.				
<b>Forest Management Plan</b>	No	No	No	No
<b>Comment:</b> The Menlo Park Fire District provides fire suppression and fire protection services to the City of Menlo Park. The California Department of Forestry and Fire Protection (Cal Fire) does not acknowledge the City of Menlo Park as being in an area known to be considered as a “wildland urban interface” environment. The Fire District boundaries do not warrant a Forest Management Plan.				
<b>Climate Action Plan</b>	Yes	No	Yes	Yes
<b>Comment:</b> The purpose of the Climate Action Plan (CAP) is to present researched strategies that will help reduce greenhouse gas emissions originating in Menlo Park, based on the findings of the City’s greenhouse gas emissions inventory analysis that is completed annually. The plan provides strategies that may be implemented over the next few years by the City, its residents, and its businesses. The CAP is updated every year as research continues to provide more emissions reduction data and as new technologies arise and economic conditions change.				
<p>The Menlo Park City Council adopted the 2030 Climate Action Plan (CAP) in July 2020 and approved amendments to it in April 2021. The CAP outlines six goals to reach zero carbon by 2030. For 2021, one of the City Council priorities is to explore policy/program options to convert 95 percent of existing buildings to all-electric by 2030. The remaining CAP goals are to:</p> <ul style="list-style-type: none"> <li>Increase electric vehicle ownership and decrease gasoline sales</li> <li>Increase access to EV charging infrastructure in multi-family and commercial properties</li> <li>Reduce vehicle miles traveled by 25 percent or an amount recommended by the Complete Streets Commission</li> <li>Eliminate the use of fossil fuels from municipal operations; and</li> <li>Develop a climate adaption plan.</li> </ul>				
<b>Emergency Operation Plan</b>	Yes	No	Yes	Yes
<b>Comment:</b> City adopted an Emergency Operation Plan in 2014. The plan still aligns with the National Incident Management System (NIMS) and the California Standardized Emergency Management System (SEMS). The Plan provides the City of Menlo Park Emergency Operations Center (EOC) responders with procedures, documentation, and user friendly checklists to effectively manage emergencies, and it also provides detailed information of supplemental requirements such as Public Information, Damage Assessment, and Recovery Operations.				
<b>Threat &amp; Hazard Identification &amp; Risk Assessment (THIRA)</b>	Yes	Yes	No	Yes
<b>Comment:</b> The City utilizes the Local Hazard Mitigation Plan and the Fire District’s Community Risk Assessment: Standards of Coverage report to support the THIRA process. A consultant has not been hired to conduct an independent THIRA for the City.				

	Local Authority	Other Jurisdiction Authority	State Mandated	Integration Opportunity?
<b>Post-Disaster Recovery Plan</b>	No	Yes	No	Yes
<i>Comment:</i> The City Emergency Operation Plan addresses establishing a Recovery Task Force to commence planning for transition to long term recovery. The City is also working with the County on turning their Countywide Debris Management Plan into a stand-alone jurisdictional annex. The City will align its recovery actions with the National and State Disaster Recovery Framework Plan. The City is working toward developing a stand-alone Post Disaster Recovery Plan. City staff have been assigned training in G270 Disaster Recovery as part of their State EOC Credentialing Training Plan.				
<b>Continuity of Operations Plan</b>	No	No	No	Yes
<i>Comment:</i> Within the City of Menlo Park, the following offices: Human Resources, City Clerk, and City Manager’s Office, are responsible for the preservation of vital records. The City will follow standard practices or policies according to the lines of succession in the absence of the City Manager based on organization hierarchy. Each department has a continuity plan for maintaining essential services during a significant event. COOP was exercised during the COVID-19 pandemic.				
<b>Public Health Plan</b>	No	Yes	No	No
<i>Comment:</i> San Mateo County Public Health				

**Table 12-4. Development and Permitting Capability**

Criterion	Response
Does your jurisdiction issue development permits? <i>If no, who does? If yes, which department?</i>	Yes Community Development Department, Building Division
Does your jurisdiction have the ability to track permits by hazard area?	Yes
Does your jurisdiction have a buildable lands inventory?	No

**Table 12-5. Fiscal Capability**

Financial Resource	Accessible or Eligible to Use?
Community Development Block Grants	Yes
Capital Improvements Project Funding	Yes
Authority to Levy Taxes for Specific Purposes	Yes
User Fees for Water, Sewer, Gas or Electric Service	Yes (Utility users’ tax on all except sewer)
Incur Debt through General Obligation Bonds	Yes
Incur Debt through Special Tax Bonds	Yes
Incur Debt through Private Activity Bonds	No
Withhold Public Expenditures in Hazard-Prone Areas	Yes (City Council authorization required)
State-Sponsored Grant Programs	Yes Office of Traffic Safety Citizens Options for Public Safety Supplemental Law Enforcement Services Fund California Governor’s Office of Emergency Services Alcoholic Beverage Control Funding for Belle Haven Child Development Center childcare
Development Impact Fees for Homebuyers or Developers	Yes
Flood Control / Sea Level Rise Hazard District	No

**Table 12-6. Administrative and Technical Capability**

Staff/Personnel Resource	Available?	Department/Agency/Position
Planners or engineers with knowledge of land development and land management practices	Yes	Public Works; Community Development (Planning & Building Divisions)
Engineers or professionals trained in building or infrastructure construction practices	Yes	Public Works; Community Development, (Planning & Building Divisions)
Planners or engineers with an understanding of natural hazards	Yes	Public Works; Community Development, (Planning & Building Divisions)
Staff with training in benefit/cost analysis	Yes	Public Works (Engineering Division), Community Development
Surveyors	Yes	Public Works and Consultants
Personnel skilled or trained in GIS applications	Yes	Public Works, Community Development, Information Technology Division
Scientist familiar with natural hazards in local area	No	N/A
Emergency manager	Yes	Police Department and Menlo Park Fire District
Grant writers	Yes	Police, Public Works, Community Development, Management Analysts (various departments) Menlo Park Fire District
Other		

**Table 12-7. Education and Outreach Capability**

Criterion	Response
Do you have a public information officer or communications office?	Yes  The City of Menlo Park has three designated Public Information Officers. These individuals train for and execute their PIO roles during EOC exercises and are aligned with meeting the PIO State EOC credentialing requirement.
Do you have personnel skilled or trained in website development?	Yes  The City Manager’s Office maintains the City website and is tasked with updating and coordinating public information. Personnel are trained and skilled in website use.
Do you have hazard mitigation information available on your website? <i>If yes, briefly describe.</i>	Yes  The City of Menlo Park has hazard mitigation information available on its website. The City also has second party web links available (Menlo Park Fire, American Red Cross, Federal Emergency Management Agency, etc.) for more information. Hazard Mitigation information is posted based on relevance of the season (summer, fall, winter, and spring). *Summer: Extreme heat, wildland fire and water drought hazard mitigation information may be posted. *Winter: Storm/flooding hazard mitigation information may be posted. *Fall: National preparedness month may include hazard mitigation information on earthquake safety. *Spring: An all hazard mitigation campaign may be posted on “Get Ready” and “What to do in the next 72 hours” for citizens to take advantage of the FEMA Community Emergency Response Team training provided by the Menlo Park Fire District.
Do you use social media for hazard mitigation education and outreach? <i>If yes, briefly describe.</i>	Yes  The City of Menlo Park primarily uses Facebook, Nextdoor and Twitter accounts. The City posts relevant hazard mitigation educational information to the public through these social media and alert notification platforms.

Criterion	Response
<p>Do you have any citizen boards or commissions that address issues related to hazard mitigation? <i>If yes, briefly describe.</i></p>	<p>Yes</p> <p>The Planning Commission serves as a recommending body to the City Council for major subdivisions, rezoning, conditional development permits, Zoning Ordinance amendments, General Plan amendments and the environmental reviews. The Environmental Quality Commission advises the City Council on matters involving environmental protection, sustainability, and sea level rise. The City of Menlo Park, in partnership with the Fire District, participates in volunteer forum meetings to discuss emergency preparedness and mitigation efforts within the City.</p>
<p>Do you have any other programs already in place that could be used to communicate hazard-related information? <i>If yes, briefly describe.</i></p>	<p>Nixle, programmable message boards</p>
<p>Do you have any established warning systems for hazard events? <i>If yes, briefly describe.</i></p>	<p>Yes</p> <p>In addition to social media and the City website, the City also participates in and uses the countywide SMC Alert system that provides emergency notifications via voice calls, SMS texts, and email.</p>

**Table 12-8. National Flood Insurance Program Compliance**

Criterion	Response
What local department is responsible for floodplain management?	Public Works, Engineering Division
Who is your floodplain administrator? (department/position)	Assistant Public Works Director
Are any certified floodplain managers on staff in your jurisdiction?	No
What is the date that your flood damage prevention ordinance was last amended?	1988 (with amendments in 1993, 1999, 2002, 2005)
Does your floodplain management program meet or exceed minimum requirements? <i>If exceeds, in what ways?</i>	Meets minimum requirements of 44 CFR 60.3 (e)
When was the most recent Community Assistance Visit or Community Assistance Contact?	2/16/2011
Does your jurisdiction have any outstanding NFIP compliance violations that need to be addressed? <i>If so, state what they are.</i>	No
Are any RiskMAP projects currently underway in your jurisdiction? <i>If so, state what they are.</i>	No
Do your flood hazard maps adequately address the flood risk within your jurisdiction? <i>If no, state why.</i>	Yes
Does your floodplain management staff need any assistance or training to support its floodplain management program? <i>If so, what type of assistance/training is needed?</i>	<p>Yes</p> <p>The City of Menlo Park would require another Certified Floodplain Manager in the Engineering Division to assist with additional floodplain improvement projects.</p>

Criterion	Response
Does your jurisdiction participate in the Community Rating System (CRS)? If yes, is your jurisdiction interested in improving its CRS Classification? If no, is your jurisdiction interested in joining the CRS program?	Yes  The City of Menlo Park attained a CRS rating of 8 in October 2020.
How many flood insurance policies are in force in your jurisdiction? <sup>a</sup> What is the insurance in force? What is the premium in force?	640 \$181,612,000 \$887,969
How many total loss claims have been filed in your jurisdiction? <sup>a</sup> What were the total payments for losses?	29 \$219,273

a. According to FEMA statistics as of March 31, 2019

**Table 12-9. Community Classifications**

	Participating?	Classification	Date Classified
FIPS Code	Yes	0608146870	N/A
DUNS#	Yes	958191975	N/A
Community Rating System	Yes	8	10/2020
Building Code Effectiveness Grading Schedule	Yes	03	12/2/2020
Public Protection	Yes	2	2013
Storm Ready	No	N/A	N/A
Firewise	No	N/A	N/A
Tsunami Ready	No	N/A	N/A

**Table 12-10. Adaptive Capacity for Climate Change**

Criterion	Jurisdiction Rating <sup>a</sup>
<b>Technical Capacity</b>	

**Jurisdiction-level understanding of potential climate change impacts** Medium

**Comment:** Environmental Quality Commission (EQC) and sustainability staff update the Climate Action Plan annually based on the findings of the community’s greenhouse gas emissions inventory analysis. The Plan outlines strategies that may take several years to implement by the City, its residents, and businesses.

Building reach codes were implemented on January 1, 2020 to restrict all new construction to be all-electric with some exceptions. This ordinance would reduce greenhouse gas emissions from the building sector and encourage residents to use renewable energy. Staff is working on the next building cycle to update its reach codes, which may include, but not limited to, some restrictions for existing buildings or more stringent reach codes for new construction.

One of the primary anticipated impacts of climate change is sea level rise and more frequent and severe flooding. The City is pursuing the SAFER Bay project through a grant application to FEMA’s Building Resilient Infrastructure and Communities (BRIC) program to protect the community from sea level rise and flooding. This is consistent with the General Plan Land Use Element Goal LU-7: Promote the implementation and maintenance of sustainable development, facilities, and services to meet the needs of the Menlo Park community. This project application proposes to construct approximately 3.7 miles of nature-based flood control and sea level rise barriers along the San Francisco Bay shoreline. This would be a significant advancement toward the ultimate goal of providing full flood protection for the residents and business near the Bay. As of July 2021, FEMA has selected the SAFER Bay project for further evaluation. Staff has incorporated funding to support this work into the fiscal year 2021-22 capital improvement program. This project aligns with the City’s 2030 CAP goal to develop a climate action adaption plan. Because this is a large project, more staff capacity may be needed and is being assessed as the City awaits notification from FEMA regarding the grant award.

Criterion	Jurisdiction Rating <sup>a</sup>
<p><b>Jurisdiction-level monitoring of climate change impacts</b></p> <p><b>Comment:</b> The City implemented an online permitting system (Accela), which helps staff analyze the number of projects that trigger the all-electric reach code restrictions. The data collected in Accela would also help analyze and develop a policy/program to help convert 95% of existing buildings to all-electric by 2030.</p> <p>In partnership with the County, air quality monitors were installed for public health and safety and the data is available on publicly accessible portals. More capacity would be needed to increase monitoring the impacts of climate change.</p>	Medium
<p><b>Technical resources to assess proposed strategies for feasibility and externalities</b></p> <p><b>Comment:</b> The City could use more technical resources to assess the proposed strategies for feasibility and externalities.</p>	Low
<p><b>Jurisdiction-level capacity for development of greenhouse gas emissions inventory</b></p> <p><b>Comment:</b> The City could use some improvement in developing the community's greenhouse gas emissions inventory.</p>	Medium
<p><b>Capital planning and land use decisions informed by potential climate impacts</b></p> <p><b>Comment:</b> The City has a number of ordinances, plans, and projects to address climate impacts through capital planning and land use decisions:</p> <ul style="list-style-type: none"> <li>•Municipal Code Section 16.43.140 is a green and sustainable building ordinance, which requires developers to submit zero waste management plans to showcase how the project will reduce waste during the construction and occupancy phase. This ordinance will help the City meet its zero waste goal of 90% diversion by 2035.</li> <li>•The City is updating the Safety Element to comply with the new changes to SB 379.</li> <li>•Development projects, both commercial and residential, need to be assessed by the standards set by the California Environmental Quality Act, which may require preparation of environmental impact reports.</li> <li>•According to Municipal Code Section 12.16.010, new construction is required to be all-electric, with a few exceptions. For example, the Menlo Park Community Center will be an all-electric building to eliminate the use of natural gas.</li> <li>•The City adopted the sustainable fleet policy in 2020, a minimum 50 percent vehicles purchased will be zero-emission by 2025 and 75 percent by 2030.</li> <li>•The City has undertaken master planning efforts in most capital planning areas in the last five years. These efforts have helped identify funding and project needs (e.g., facilities, streets, transportation, parks, stormwater, etc.), but additional resources (funding and staff or consultants) will be needed to deliver the needed projects to address expected climate impacts. Funds to operate and maintain new infrastructure for adapting to climate change will also be needed.</li> <li>•Potentially more staff resources are needed to process building permits and more outreach is needed to educate the public about the reach codes.</li> </ul>	Medium

Criterion	Jurisdiction Rating <sup>a</sup>
<p><b>Participation in regional groups addressing climate risks</b></p> <p><b>Comment:</b></p> <ul style="list-style-type: none"> <li>• A councilmember is a board member of Peninsula Clean Energy, which offers renewable energy to Menlo Park residents. Peninsula Clean Energy offers at minimum 50% renewable energy and 90% greenhouse gas free electricity. With renewable energy powering an all-electric building, the occupants and indoor air quality may significantly improve health and safety.</li> <li>• Both councilmember and staff participate in South Bay Waste Management Authority and Technical Advisory Committee monthly meets to discuss innovative waste reduction and recycling programs. For instance, the group is discussing the upcoming Senate Bill 1383, which is to enforce a more stringent organics program and surplus food recovery. When food waste decomposes in the landfill without air, it creates methane, which is harmful to the environment.</li> <li>• Staff and a councilmember liaison participate in with San Mateo Flood &amp; Sea Level Rise District to discuss climate change impacts of sea level rise and flooding across jurisdictional boundaries. Menlo Park City Council also supported pursuit of the SAFER Bay project for a FEMA BRIC grant application, which proposes to construct approximately 3.7 miles of nature-based flood control and sea level rise barriers along the San Francisco Bay shoreline. This would be a significant advancement toward the ultimate goal of providing full flood protection for the residents and business near the Bay. As of July 2021, FEMA has selected the SAFER Bay project for further evaluation. Staff has incorporated funding to support this work into the fiscal year 2021-22 capital improvement program.</li> <li>• The City partners with local organizations to help monitor and implement climate change goals. For instance, Joint Venture Silicon Valley will assist in reaching the goal to increase EV of new vehicle ownerships to 100% by 2025 and to reduce gasoline sales by 10% a year from the 2018 baseline.</li> <li>• City/County Association of Governments of San Mateo County (C/CAG) staff manage the County’s stormwater program and permitting requirements. City staff actively participate in C/CAGs stormwater committees, and a City Councilmember serves on the C/CAG board.</li> <li>• ICLEI is an international non-governmental organization that promotes sustainable development and provides technical consulting to help the City meet its sustainability initiatives.</li> <li>• BAWSCA and Flows to Bay offer various water conservation programs, such as rain barrel rebates and Lawn Be Gone programs.</li> </ul>	<p>Medium</p>
<p><b>Implementation Capacity</b></p> <p><b>Clear authority/mandate to consider climate change impacts during public decision-making processes</b></p> <p><b>Comment:</b> On December 10, 2019, the City Council adopted Resolution No. 6535 declaring a climate emergency. During public decision-making processes, internal and external stakeholders must comply with the City’s sustainability-related policies and ordinances. The City would need more capacity or to reduce other projects and priorities to adopt and implement programs, ordinances, or solutions to further advance in climate change adaptation.</p>	<p>Medium</p>
<p><b>Identified strategies for greenhouse gas mitigation efforts</b></p> <p><b>Comment:</b> Menlo Park City Council adopted the 2030 Climate Action Plan (CAP) in July 2020 and approved amendments to it in April 2021. The CAP outlines six goals to reach zero carbon by 2030. Five of these goals address mitigation, as listed below. The CAP goals are to:</p> <ul style="list-style-type: none"> <li>• Explore policy/program options to convert 95 percent of existing buildings to all-electric by 2030</li> <li>• Increase electric vehicle ownership and decrease gasoline sales</li> <li>• Increase access to EV charging infrastructure in multi-family and commercial properties</li> <li>• Reduce vehicle miles traveled by 25 percent or an amount recommended by the Complete Streets Commission</li> <li>• Eliminate the use of fossil fuels from municipal operations.</li> </ul> <p>The scope of work for 2021 implementation are the following:</p> <ul style="list-style-type: none"> <li>• Complete a cost effectiveness analysis on various policy/program pathways towards achieving 95% electrification by 2030.</li> <li>• Collaborate with Joint Venture Silicon Valley to increase the number of new vehicle purchase to be electric vehicles (EV) and decrease the gasoline sales by 10%.</li> <li>• Promote and market incentives to expand access to EV charging stations in multi-family and commercial properties.</li> <li>• Reduce vehicle miles traveled through SB2 Housing grant, completion of Transportation Management Association feasibility study, and implementation of vehicle miles traveled guidelines for new development.</li> <li>• Update the Safety Element of Menlo Park’s General Plan to respond to SB 379.</li> </ul>	<p>High</p>

Criterion	Jurisdiction Rating <sup>a</sup>
<p><b>Identified strategies for adaptation to impacts</b></p> <p><b>Comment:</b> The sixth goal from the City's Climate Action Plan is to develop a climate adaptation plan. The City has participated in past regional efforts to develop adaptation plans for sea level rise, including the SAFER Bay Feasibility Study, led by the San Francisquito Creek Joint Powers Authority; and the Metropolitan Transportation Commission's Dumbarton Bridge West Approach + Adjacent Communities Resilience Study. The City has applied for a FEMA BRIC grant to support implementation of the first phase of the SAFER Bay project and would continue to partner with other stakeholders to complete the project.</p>	High
<p><b>Champions for climate action in local government departments</b></p> <p><b>Comment:</b></p> <ul style="list-style-type: none"> <li>• The City has a sustainability division to implement the climate action plan and collaborates with multiple departments to adopt climate-related policies and initiatives. More capacity is needed to adopt and implement new programs, ordinances, and implement the CAP goals.</li> <li>• As of fiscal year 2020-21, the City has 109 fleet vehicles, which include vehicles, motorcycles, and parking enforcement buggies. Out of the total fleet vehicles, twenty-one are hybrids and four are all-electric vehicles. The City is waiting for technology to advance for electric utility vehicles, which may be available within the next three years. Public Works is also transitioning its maintenance equipment to electric.</li> <li>• The Building Division implemented local energy code amendments to the building code (reach codes), which went above and beyond State and County recommendations.</li> <li>• The Community Development Department implemented a green and sustainable building ordinance.</li> <li>• In 2015, several solar photovoltaic panels were installed on various City facilities.</li> <li>• The City installed 4 electric vehicle charging stations (with 2 charging ports each) for public use.</li> <li>• The Police Department is currently transitioning their paper parking permits to paperless permits.</li> <li>• The Community Development and Public Works Departments transitioned from paper permitting applications to electronic submittals.</li> <li>• The City's transportation demand management coordinator provides support to local employers and City employees to provide information about non-single occupancy vehicle travel options, which can help reduce vehicle miles traveled and emissions from transportation mobile sources.</li> </ul>	Medium
<p><b>Political support for implementing climate change adaptation strategies</b></p> <p><b>Comment:</b></p> <ul style="list-style-type: none"> <li>•Menlo Park City Council was one of the first cities to adopt reach code, which nearly eliminated natural gas from new buildings. City Council also adopted a resolution to declare climate emergency, which demands accelerated actions on the climate crisis and requests regional collaboration to address climate change. The former mayor also signed a resolution to reaffirm the City's commitment to tackle climate change at a local level.</li> <li>•All six Climate Action Plan goals are on City Council's 2021 priorities and work plan: two out of nine priority projects are related to CAP.</li> <li>•Menlo Park City Council also supported pursuit of the SAFER Bay project FEMA BRIC grant application.</li> <li>•The Environmental Quality Commission continues to advise City Council on implementing the CAP goals.</li> </ul>	High
<p><b>Financial resources devoted to climate change adaptation</b></p> <p><b>Comment:</b> The City filed the FEMA BRIC grant application, which would help develop a climate action adaptation plan to protect the community from sea level rise and flooding. More capacity is likely to be needed in this effort and other climate change adaption.</p>	Medium
<p><b>Local authority over sectors likely to be negative impacted</b></p> <p><b>Comment:</b></p> <ul style="list-style-type: none"> <li>•Code Enforcement officers may be impacted if new building requirement ordinances are adopted that require enforcement resources, but not enough information is known at this time to assign a rating.</li> <li>•Some business industries (such as restaurants, research and development or life-science) may be negatively impacted by the reach codes; however, those business may be exempted from the reach codes as outlined in the Municipal Code Section 12.16.010.</li> <li>•Gas and oil manufacturing sectors may be negatively impacted if the City reduces its gasoline consumption (either for vehicles or for building appliances). This impact would be related to the 2030 CAP goals and the reach codes, but not enough information is known at this time to assign a rating.</li> </ul>	Unsure



Criterion	Jurisdiction Rating <sup>a</sup>
<b>Public Capacity</b>	
<b>Local residents knowledge of and understanding of climate risk</b>	Medium
<i>Comment:</i> •The Environmental Quality Commission (EQC), a commission body made up of seven Menlo Park residents, created the 2030 CAP. The Complete Streets Commission, another resident-based commission body of nine members, is anticipated to develop a vehicle miles traveled reduction goal by 2023. •Strong advocacy occurs when climate policies are considered by City Council. Several residents expressed interest to ban gas leaf blowers by adopting an ordinance. •More outreach needs to be done to understand the community’s knowledge and understanding of climate risk. A resolution was approved in April 2021 that approved the scope of work for 2021 implementation of the CAP and to educate residents about climate emergency and to include health, socio-economic, and racial equity in policymaking and climate solutions.	
<b>Local residents support of adaptation efforts</b>	Unsure
<i>Comment:</i> Not enough information is known to assign a rating. More outreach is needed.	
<b>Local residents’ capacity to adapt to climate impacts</b>	Unsure
<i>Comment:</i> Not enough information is known to assign a rating. More outreach is needed.	
<b>Local economy current capacity to adapt to climate impacts</b>	Unsure
<i>Comment:</i> Not enough information is known to assign a rating. More outreach is needed.	
<b>Local ecosystems capacity to adapt to climate impacts</b>	Unsure
<i>Comment:</i> Not enough information is known to assign a rating. More outreach is needed.	

- a. High = Capacity exists and is in use; Medium = Capacity may exist but is not used or could use some improvement;  
Low = Capacity does not exist or could use substantial improvement; Unsure= Not enough information is known to assign a rating.

## 12.5 INTEGRATION REVIEW

For hazard mitigation planning, “integration” means that hazard mitigation information is used in other relevant planning mechanisms, such as general planning and capital facilities planning, and that relevant information from those sources is used in hazard mitigation. This section identifies where such integration is already in place, and where there are opportunities for further integration in the future. Resources listed at the end of this annex were used to provide information on integration. The progress reporting process described in Volume 1 of the hazard mitigation plan will document the progress of hazard mitigation actions related to integration and identify new opportunities for integration.

### 12.5.1 Existing Integration

Some level of integration has already been established between local hazard mitigation planning and the following other local plans and programs:

- **General Plan**—The Safety Element of the General Plan (adopted May 21, 2013) complies with Assembly Bill No. 2140 and is aimed at reducing potential risk of death, injuries, damage to property, and the economic and social dislocation resulting from fire, flood, geologic and other hazards. The General Plan provides policies and standards for the type, location, intensity, and design of development in areas of potential hazards. The intent is not to remove all risks associated with each specific type of hazard, but to reduce risks to life and property and to make informed decisions about land use and development near these hazards.
- **Climate Action Plan/Climate Change**—The City’s 2030 Climate Action Plan outlines strategies to reduce greenhouse gas emissions and fight climate change. These goals were reviewed to identify cross-planning initiatives that serve both adaptation and mitigation objectives.

- **Zoning Code**—The Zoning Code (Municipal Code Title 16) includes an Open Space and Conservation District (Chapter 16.48). The purpose and intent of this district is:
  - To protect the public health, safety, and welfare
  - To protect and preserve open space land as a limited and valuable resource
  - To assure its continued availability for the following: As agricultural land, scenic land, recreation land, conservation, or natural resource land; for the containment of urban sprawl and the structuring of urban development, and for the retention of land in its natural or near natural state to protect life and property in the community from the hazards of fire, flood, and seismic activity; and
  - To coordinate with and carry out federal, state, regional, county and city open space plans.
- **Stormwater Management**—New and redevelopment projects are required to reduce the quantity and improve the quality of stormwater that flows into the City’s collection system from private property, local creeks, the San Francisco Bay, and the Pacific Ocean. Depending on the size of the project, the City may require special features that minimize pollutants at their source, infiltrate more rain into the soil and treat stormwater before it leaves the site. For larger projects, an agreement to maintain the stormwater treatment measure is also required.
- **Growth Management**—For each new project, developers are required to conduct an environmental impact report and comply with the California Environmental Quality Act.
- **Environmental Protection**—The City has ordinances and policies related to environmental protection:
  - In January 2020, the City adopted reach codes for new construction to reduce greenhouse gas emissions from the building sector and encourage the use of renewable and clean energy. The reach codes are local modifications to account for the climatic, topographic, and geographic conditions that exist in Menlo Park.
  - The City’s Climate Action Plan was adopted in July 2020 and several of its goals are related to environmental protection. Two of the goals are related to electric vehicles: to promote the purchase of electric vehicles and increase EV charging stations in multi-family and commercial buildings, and to reduce greenhouse gas emissions and improve air quality.
  - The City adopted a Sustainable Vehicle Fleet Policy to increase the number of zero-emission City fleet vehicles.
  - The City has tree pruning program to ensure dead trees and limbs are removed to reduce wildfire risk. The City is transitioning to plant low-water tolerant replacement trees to adapt to the drought season while maintaining the urban canopy.
- **Flood Damage Prevention**—The ordinance (Municipal Code Section 12.42.13) minimizes public and private losses due to flood conditions in specific areas by provisions designed:
  - To protect human life and health
  - To minimize expenditure of public money for costly flood control projects
  - To minimize the need for rescue and relief efforts associated with flooding and generally undertaken at the expense of the general public
  - To minimize prolonged business interruptions
  - To minimize damage to public facilities and utilities such as water and gas mains, electric, telephone and sewer lines, streets and bridges located in areas of special flood hazard
  - To help maintain a stable tax base by providing for the second use and development of areas of special flood hazard so as to minimize future flood blight areas
  - To ensure that potential buyers are notified that property is in an area of special flood hazard; and
  - To ensure that those who occupy special flood hazard areas assume responsibility for their actions.

- **Capital Improvement Plan**—The capital improvement plan includes projects that can help mitigate potential hazards. The City will act to ensure consistency between the hazard mitigation plan and the current and future capital improvement plans following this update. The hazard mitigation plan may identify new possible funding sources for capital improvement projects and may result in modifications to proposed projects based on results of the risk assessment.
- **Urban Water Management Plan**—The Urban Water Management Plan assesses the reliability of water sources over a 20-year planning time frame and describes demand management measures and water shortage contingency plans.
- **Water Shortage Contingency Plan**—The Water Shortage Contingency Plan serves as a standalone document to be engaged in the case of a water shortage event, such as a drought or supply interruption, and defines specific policies and actions that will be implemented at various shortage level scenarios. The primary objective of the Water Shortage Contingency Plan is to ensure that Menlo Park Municipal Water has in place the necessary resources and management responses needed to protect health and human safety, minimize economic disruption, and preserve environmental and community assets during water supply shortages and interruptions. Consistent with California Water Code §10632, the Water Shortage Contingency Plan includes six levels to address shortage conditions ranging from up to 10% to greater than 50% shortage, identifies a suite of demand mitigation measures for Menlo Park Municipal Water to implement at each level, and identifies procedures for Menlo Park Municipal Water to annually assess whether or not a water shortage is likely to occur in the coming year.

## 12.5.2 Opportunities for Future Integration

The capability assessment presented in this annex identified the following plans and programs that do not currently integrate hazard mitigation information but provide opportunities to do so in the future:

- **Water System Emergency Action Plan**—Required by the State Department of Environmental Health back in 2004. This Plan was written on 12/29/2004 and was updated in 2005, 2011 and 2013, 2016, 2019 and is currently being updated for 2021. The plan can be integrated with the hazard mitigation plan by re-writing it to confirm to the National Incident Management System (NIMS) and attaching it as an appendix.
- **Climate adaptation plan**—The City will develop a climate adaptation plan that would focus on resiliency planning and updating the General Plan Safety Element to comply with recent changes to Senate Bill 379.
- **General Plan Update; Housing, Safety, and Environmental Justice Elements**—The City is currently working on updating/creating the General Plan Housing, Safety, and Environmental Justice Elements. As part of the sustainable and environmental planning guiding principle, the updates will establish goals, policies, and programs that incorporate mitigation strategies to natural hazards, as appropriate. The Safety Element will be updated to comply with Senate Bill 379.
- **Post-Disaster Recovery Plan**—The City does not have a recovery plan and intends to develop one as a mitigation planning action during the next five years. The plan will build on the goals and objectives identified in the hazard mitigation plan. The City is also working with the County on turning the Countywide Debris Management Plan into a stand-alone jurisdictional annex. The City will align its recovery actions with the National and State Disaster Recovery Framework Plan.
- **Stormwater Plan**—The Engineering Division is in the process of updating the stormwater master plan. The plan, when completed, will model the entire City storm drain network and identify areas vulnerable to localized flooding and identify capital projects to mitigate the flooding in these areas. The plan also

identifies measures to comply with state mandated requirements under the NPDES permitting requirements.

- **Shoreline Management Plan**—The City does not have a Shoreline Management Plan; however, the City has a few ongoing projects to help manage the risks associated with the shoreline along the Bayfront Canal-Atherton Channel and the former salt ponds.

## 12.6 RISK ASSESSMENT

### 12.6.1 Jurisdiction-Specific Natural Hazard Event History

Table 12-11 lists past occurrences of natural hazards for which specific damage was recorded in this jurisdiction. Other hazard events that broadly affected the entire planning area, including this jurisdiction, are listed in the risk assessments in Volume 1 of this hazard mitigation plan.

**Table 12-11. Past Natural Hazard Events**

Type of Event	FEMA Disaster #	Date	Damage Assessment
Wildfires: poor air quality (CZU Fire)	DR-4558	August 14-September 26, 2020	Unknown
Covid-19 Pandemic	DR-4482	January 20, 2020 - present	Unknown
Severe Winter Storms	DR-4308	February 1-23, 2017	Unknown
Severe Storm (El Niño)	N/A	December 23, 2012	\$3 million creek bank erosion private property \$820,000 residential and businesses
Severe Storm (El Niño)	DR-1203	February 9, 1998	Unknown
Loma Prieta Earthquake	DR-845	October 18, 1989	Unknown

### 12.6.2 Hazard Risk Ranking

Table 12-12 presents a local ranking of all hazards of concern for which this hazard mitigation plan provides complete risk assessments. As described in detail in Volume 1, the ranking process involves an assessment of the likelihood of occurrence for each hazard, along with its potential impacts on people, property, and the economy. Mitigation actions target hazards with high and medium rankings.

**Table 12-12. Hazard Risk Ranking**

Rank	Hazard	Risk Ranking Score	Risk Category
1	Flood	87	High
2	Earthquake	84	High
3	Sea Level Rise / Climate Change	72	High
4	Severe Weather/Extreme Weather	24	Medium
5	Dam Failure	72	Low*
6	Landslide/Mass Movements	72	Low**
7	Drought	9	Low
8	Tsunami	2	Low

\* After reviewing the Dam Failure map provided by Tetra Tech, City of Menlo Park is not in the Inundation Area.

\*\* The City of Menlo Park does not experience a significant amount of landslides/mass movements, which is why the risk ranking changed from High to Low.

### **12.6.3 Jurisdiction-Specific Vulnerabilities**

Volume 1 of this hazard mitigation plan provides complete risk assessments for each identified hazard of concern. This section provides information on a few key vulnerabilities for this jurisdiction. Available jurisdiction-specific risk maps of the hazards are provided at the end of this annex.

#### **Repetitive Loss Properties**

Repetitive loss records are as follows:

- Number of FEMA-identified Repetitive-Loss Properties: 0
- Number of FEMA-identified Severe-Repetitive-Loss Properties: 0
- Number of Repetitive-Loss Properties or Severe-Repetitive-Loss Properties that have been mitigated: 0

#### **Other Noted Vulnerabilities**

The following jurisdiction-specific issues have been identified based on a review of the results of the risk assessment, public involvement strategy, and other available resources:

These public facilities are located in either flood hazard areas, along the fault lines, high liquefaction areas, and/or sea level rise areas:

- Menlo Park Community Center (formerly site of the Menlo Park Senior Center, Onetta Harris Community Center, Youth Center, and Belle Haven Pool)
- Belle Haven Child Development Center
- Menlo Park Police Neighborhood Services Center
- Belle Haven Library
- Bedwell Bayfront Park Landfill and Gas Flare
- Chrysler Pump Station
- U.S. Veteran Administration Medical Center
- Nealon Park Little House and Nursery School

Not all structures are listed above because it is assumed the hazards with “High” ranking from Table 12-12 would affect all the structures in the city. Therefore, a comprehensive list of all structures is not needed.

These local street intersections have experienced flooding during heavy rain events:

- Middlefield Rd and Ravenswood Ave.
- Atherton Channel and Haven Ave.
- Pope St. and Elm St. intersection
- Corner of Scott Dr. and Bohannon Dr.
- Campbell Ave. and Scott Dr.
- University Dr. and Middle Ave.
- Menalto Ave. near the Highway 101 sound wall

- Emma Ln.
- O’Brien Dr. and Kavanaugh Dr.
- O’Brien Dr. and Casey Ct.
- Bay Rd. and Menlo Oaks Dr.
- Bay Rd. and Berkeley Ave.
- Laurel St. and Ravenswood Ave.
- El Camino Real and Cambridge Ave.

These are the results from the public survey from residents who live within the 94025 ZIP code:

- Out of 25 natural hazards listed, residents expressed:
  - Extremely concerned for climate change, poor air quality, public health, and wildfire; and
  - Very concerned about earthquake, drought, power failure, flooding, and extreme heat
- Residents most commonly experienced these hazard events within the past five years:
  - Poor air quality due to nearby wildfire
  - Public health – epidemic or pandemic
  - Extreme heat
  - Drought; and
  - Climate change

According to the National Climatic Data Center, the City of Menlo Park and its neighboring cities (Atherton, East Palo Alto, Unincorporated West Menlo Park, North Fair Oaks, and Woodside) reported 12 flood hazard events (out of 16 total events) due to heavy rain within the past six years.

Mitigation actions addressing these issues were prioritized for consideration in the action plan for this annex.

## 12.7 STATUS OF PREVIOUS PLAN ACTIONS

Table 12-13 summarizes the actions that were recommended in the previous version of the hazard mitigation plan and their implementation status at the time this update was prepared.

**Table 12-13. Status of Previous Plan Actions**

Action Item	Completed	Removed; No longer Feasible	Carried Over to Plan Update	
			Check if Yes	Action # in Update
<p><b>MP-1</b>—Where appropriate, support retro-fitting, purchase or relocation of structures located in high hazard areas and prioritize those structures that have experienced repetitive losses.</p> <p><b>Comment:</b> Menlo Park has a Planning Commission that oversees future building development which takes into consideration high risk hazards. Homeowners in high risk areas are required to take out home insurance associated with potential risks that expose their properties.</p> <p>No city facilities have been vulnerable to recurring losses, so relocation is no longer feasible. On the other hand, the City will continue to support retro-fitting of other structures, but the city’s role in this for private property is limited.</p>			✓	MPK-1

Action Item	Completed	Removed; No longer Feasible	Carried Over to Plan Update	
			Check if Yes	Action # in Update
<p><b>MP-2</b>—Integrate the hazard mitigation plan into other plans, ordinances and programs that dictate land use decisions within the community.</p> <p><b>Comment:</b> The City has incorporated the LHMP in their General Plan Safety Element pertaining to any associated risks or hazards; and takes into consideration these risks during building development or future land-use planning (adopted May 2013). The City is in the process of updating the General Plan Safety Element and will continue to integrate and implement the LHMP (tentative completion in 2022).</p>			✓	MPK-2
<p><b>MP-3</b>—Integrate the hazard mitigation plan into other plans and programs that support infrastructure investments, such as the five-year capital improvement program</p> <p><b>Comment:</b> The City has integrated its hazard mitigation planning as part of the capital improvement program by using prioritization criteria such as public health and safety risks, protecting infrastructure, ability to reduce greenhouse gas emissions and support the City’s 2030 climate action plan, and relationship to adopted plans (including the LHMP). Projects that have therefore been prioritized include funding for the Bayfront Canal and Atherton Channel flood protection project, the San Francisquito Creek upstream flood protection project, the reconstruction of the Chrysler stormwater pump station, and the SAFER Bay sea level rise protection project.</p>			✓	MPK-2
<p><b>MP-4</b>—Develop and implement a program to capture perishable data after significant events (e.g., high water marks, preliminary damage estimates, damage photos) to support future mitigation efforts including the implementation and maintenance of the hazard mitigation plan.</p> <p><b>Comment:</b> The City developed an application for conducting damage assessment following the guidelines of ATC-20 that has the ability to record preliminary damage estimates and photos. The program is called the Damage Assessment Reporting System. The City uses several project management tools, including Dropbox, ArcGIS and Monday.com for archiving information. Per County of San Mateo guidance, the City also adheres to filling out the “SMC Initial Damage Estimate” sheet.</p>				
<p><b>MP-5</b>—Support the County-wide initiatives identified in Volume I of the hazard mitigation plan.</p> <p><b>Comment:</b> The City continues to partner with the County on all related hazard reduction, emergency preparedness, and disaster response efforts. Elected Officials serve as part of the San Mateo County Emergency Services Council in accordance with the Joint Powers Agreement. Participation in the Authority is to ensure cooperative emergency planning and response. All participating members and partners are expected to attend all regular and special meetings of the Area Emergency Services Council, agree to active participation by their jurisdictions in the development of plans and training programs, drills, exercises, and training opportunities, and otherwise assist in supporting the implementation of this agreement.</p>				MPK-3
<p><b>MP-6</b>—Actively participate in the plan maintenance protocols outlined in Volume I of the hazard mitigation plan.</p> <p><b>Comment:</b> The Menlo Park Fire Protection District, in partnership with the City of Menlo Park, supports the facilitation of the maintenance protocols of the Hazard Mitigation Plan. Each department has taken ownership of their hazard mitigation projects and provides updates to the Point of Contact related to the completion of projects annually. GIS mapping tools are being developed to engage the public.</p>				MPK-4

Action Item	Completed	Removed; No longer Feasible	Carried Over to Plan Update	
			Check if Yes	Action # in Update
<p><b>MP-7</b>—Continue to maintain good standing and compliance under the National Flood Insurance Program (NFIP). This will be accomplished through the implementation of floodplain management programs that will, at a minimum, meet the requirements of the NFIP:</p> <p>Enforcement of the flood damage prevention ordinance Participate in floodplain identification and mapping updates; and Provide public assistance/information on floodplain requirements and impacts.</p> <p><b>Comment:</b> The City of Menlo Park has been recognized for performing floodplain management activities above and beyond the minimum requirements for the Federal Emergency Management Agency (FEMA) National Flood Insurance Program (NFIP). As a result of the City's continuing efforts in floodplain management activities, Menlo Park has been certified to participate in the Community Rating System (CRS) program and received Class 8 effective of October 1, 2020 (expiration date on October 31, 2023). The City is compliant with NFIP requirements and flood-plain management programs including coordination on mapping updates and providing information and assistance to residents included in the program. The next annual recertification is due by August 1, 2021. The process involves certifying that the City have been performing the agreed upon activities and updating data.</p>				MPK-5
<p><b>MP-8</b>—Work with building officials to identify ways to improve the jurisdiction's BCEGS classification</p> <p><b>Comment:</b> The concept behind the Building Code Effectiveness Grading Schedule (BCEGS) is that municipalities with well-enforced building code requirements designed to mitigate losses from natural hazards, demonstrate better loss experience, and can ultimately lower citizens' insurance costs. Effectiveness Classification ranges from Class 1 to Class 10, with Class 1 being the highest/top score. In May 2021, the City of Menlo Park received BCEGS Class 3 for single- and two-family residential property and Class 3 for commercial and industrial property. This is a significant achievement that reflects the City's ongoing dedication for community development that is safe and supportive of Menlo Park's outstanding quality of life.</p>				
<p><b>MP-9</b>—Develop a post-disaster recovery plan and debris management plan.</p> <p><b>Comment:</b> The County developed a Debris Management plan in August 2020. Menlo Park does not have a stand-alone Debris Management Plan. The Public Works Department is reviewing the County plan with the goal of doing an independent plan aligned with the County Plan.</p>				MPK-6
<p><b>MP-10</b>—Develop mitigation controls (continuity of government plans) and ensure force protection measures are in place in relation to vulnerable critical facilities within the City (police stations, fire stations, emergency operation center, City Hall, emergency shelters, etc.)</p> <p><b>Comment:</b> The City is working with the County to support the development of a Continuity Operation Plan in order to align with countywide plans. The Menlo Park Fire Protection District, in partnership with the City, is working toward development.</p>				MPK-7
<p><b>MP-11</b>—Develop a plan for expediting the repair and restoration of the water systems through stockpiling of shoring materials, temporary pumps, surface pipelines, portable hydrants, and other supplies, such as those available through the Water Agency Response Network (WARN).</p> <p><b>Comment:</b> The City's 2016 Water System Emergency Response Plan will be updated with a 2021 Water System Emergency Response Plan by 12/31/2021. The City has cooperative agreements in place with emergency service/disaster service contractors. The Public Works Department and Menlo Park Municipal Water has on-call personnel 24/7 which coordinate timely repairs and restoration of water systems in the city. The City has interconnect agreements in place with adjacent water providers. The City coordinates with West Bay Sanitary Sewer District with repair and restoration of the wastewater systems.</p>				
<p><b>MP-12</b>—Continue to participate in the Public Works Mutual Aid Agreement—San Mateo County in accordance with resource sharing and resource coordination.</p> <p><b>Comment:</b> The City continues to participate in the Public Works Mutual Aid Agreement and has also piloted a system called the Field Emergency Resource Management System, an interactive web-based emergency resources sharing application. The City also uses the ICS-213RR Resource Request Form.</p>				



Action Item	Completed	Removed; No longer Feasible	Carried Over to Plan Update	
			Check if Yes	Action # in Update
<p><b>MP-13</b>—Continue to ensure that critical intersection traffic lights function following loss of power by testing battery back-ups, emergency generators, or lights powered by alternative energy sources such as solar.</p> <p><b>Comment:</b> The City has an on-call contract with CalWest for emergency response to traffic signal outages and has two portable generators on hand in case of power outages. Monthly maintenance on all generators is completed by the fleet section of the Public Works Department. In addition, the City has secured a set of solar panels and 12-volt batteries. This solar charging station will be installed at the Corporation Yard to provide fully charged batteries on stand-by for lighted crosswalks.</p>				
<p><b>MP-14</b>—Develop emergency plans or MOU agreements with neighboring mutual aid providers.</p> <p><b>Comment:</b> The City continues to promote Field Emergency Resource Management System, Field Emergency Resource Management System, which facilitates our emergency resources sharing capabilities and MOU agreements among neighboring mutual aid providers countywide. The system has been tested and exercised. The City also participates in the Disaster Service Committee that is a multi-jurisdictional emergency planning work group. The City has a Public Works Mutual Aid Agreement in place by Resolution No. 6547 adopted in March 2020. Through a standardized Emergency Operation Plan between East Palo Alto, Atherton, Menlo Park, and the Fire District the City maintains a system of neighboring unity and structure.</p>				
<p><b>MP-15</b>—Implement maintenance and storm preparedness plans that include the annual clearing of storm water drains and culverts, drainage ditches, and other waterways, such as the Atherton Channel and San Francisquito Creek, to maintain flood protection.</p> <p><b>Comment:</b> The City has a Flood Response Annex which includes the annual clearing of storm water drains and culverts, drainage ditches, and other waterways, such as the Atherton Channel and San Francisquito Creek, to maintain flood protection. The City also participates in the San Francisquito Creek Joint Powers Authority annual Flood Preparedness Workshops. The City conducts an annual inspection of the storm drain system before the rainy season. As part of the City's in-house inspection and cleaning program on a five-year routine basis, the contractor focuses on root cleaning, line clearing, and CCTV line inspection.</p>			✓	MPK-8
<p><b>MP-16</b>—Continue to coordinate with the City of Redwood City on the Bayfront Canal flood control improvements.</p> <p><b>Comment:</b> The City has been working with San Mateo Flood and Sea Level Rise Resiliency District, San Mateo County, Redwood City and the Town of Atherton on the design and construction of the Bayfront Canal Bypass Project. An MOU was approved by all partner agencies in November 2020 and construction commenced in 2021.</p>				
<p><b>MP-17</b>—Continue to coordinate with the San Francisquito Creek Joint Powers Authority on San Francisquito Creek and SAFER Bay flood control projects.</p> <p><b>Comment:</b> The City continues to coordinate with the San Francisquito Creek JPA on the Downstream of 101 and Upstream of 101 flood control projects, as well as the development of the SAFER Bay project. In 2021, the City applied for a FEMA Building Resilient Infrastructure and Communities (BRIC) grant for several reaches of the SAFER Bay Project, in partnership with the JPA, PG&amp;E, and Facebook.</p>				MPK-9
<p><b>MP-18</b>—Continue to coordinate with the California Coastal Conservancy and the U.S. Fish &amp; Wildlife Service on the South Bay Salt Pond Restoration Project.</p> <p><b>Comment:</b> The coordination work with the California Coastal Conservancy is ongoing. The City is working on a levee project currently with members.</p>				MPK-10
<p><b>MP-19</b>—Upgrade the Chrysler Pump Station to improve flood protection in the Bayfront area.</p> <p><b>Comment:</b> The design of the Chrysler Pump Station is currently underway, and funding was secured in 2020 with a \$5 million FEMA Hazard Mitigation Grant program award. Construction is anticipated to begin in 2021 and completed by 2023.</p>				MPK-11
<p><b>MP-20</b>—Develop and implement a Green Infrastructure Plan to improve storm water quality and flood protection.</p> <p><b>Comment:</b> The City Council adopted the Green Stormwater Infrastructure Plan in 2019. The City has also hired a consultant to develop a storm water master plan.</p>				

Action Item	Completed	Removed; No longer Feasible	Carried Over to Plan Update	
			Check if Yes	Action # in Update
<p><b>MP-21</b>—Produce hazards maps that take into account the impacts of flooding due to climate change.</p> <p><b>Comment:</b> San Mateo County’s Office of Sustainability published the draft Sea Level Rise Vulnerability Assessment for San Mateo County in 2018. The study includes maps for a number of sea level rise scenarios, which includes areas that would be impacted in Menlo Park. The City also has GIS staff that references flood inundation maps to incorporate data into other City planning documents and analyses.</p>				MPK-12
<p><b>MP-22</b>—Develop an Adaptation to Climate Change Plan and integrate into the Local Hazard Mitigation Plan.</p> <p><b>Comment:</b> In early 2020, the San Mateo County Flood and Sea Level Rise District was formed to represent all cities and the County of San Mateo. The City of Menlo Park is an active member of this agency that is developing plans and projects to protect areas of the city vulnerable to sea level rise and climate change. In July 2020, the City adopted, and in April 2021 updated, the Climate Action Plan that identifies climate change resiliency as a priority for Menlo Park.</p>				MPK-13
<p><b>MP-23</b>—Continue to participate with the San Mateo County Flood and Sea level Rise Resiliency District on key flood control projects.</p> <p><b>Comment:</b> The Sea Level Rise Vulnerability Assessment was completed in 2018 with substantial input from the City of Menlo Park. Following completion of the assessment and the passage of AB825, the San Mateo County Flood and Sea level Rise Resiliency District was formed as noted in MP-17 and MP-22. The City participates in FSLRRD meetings and is a stakeholder/partner on key flood control projects.</p>				MPK-14
<p><b>MP-24</b>—Develop a recycled water feasibility study and adopt a recycled water ordinance for the use of recycled water in the Menlo Pak Municipal Water District service area.</p> <p><b>Comment:</b> West Bay Sanitary District completed preparation of its recycled water feasibility study of the Bayfront area of Menlo Park in May 2019. West Bay also completed construction of the Sharon Heights recycled water project with operations commencing in October 2020 to provide recycled water to the Sharon Heights Golf and Country Club.</p>				
<p><b>MP-25</b>—Plan, design and build emergency water supply wells to serve residents during times of emergencies that result in a loss of water supply.</p> <p><b>Comment:</b> The City began construction of its first emergency water supply well in 2018 and the project was completed in 2020, awaiting issuance of permits from the State Department Water Resources, expected in 2021. The City is exploring considerations for a second emergency well and/or reservoir in partnership with Ravenswood City School District at the Willow Oaks School and park sites.</p>				
<p><b>MP-26</b>—Update the Seismic Vulnerability Assessment of the City’s water distribution system.</p> <p><b>Comment:</b> In June 2021, the City used EPA’s Vulnerability Self-Assessment Tool (VSAT) to complete a Risk and Resiliency Assessment to evaluate all risks including seismic assessment of the City’s water distribution system.</p>				
<p><b>MP-27</b>—Plan, design, and build for the undergrounding of utilities in the downtown parking areas.</p> <p><b>Comment:</b> The City Council established three underground utility districts in February 2020, one of which is located downtown. The California Public Utilities Commission recently adopted major changes to the Rule 20A program (which funded undergrounding utilities), requiring the City to reassess the viability of this (or any) undergrounding project in 2021. The undergrounding of utilities in the downtown parking areas was identified as a lower priority area than other corridors in the City by the City Council in mid-2021.</p>		✓		

Action Item	Completed	Removed; No longer Feasible	Carried Over to Plan Update	
			Check if Yes	Action # in Update
<p><b>MP-28</b>—Develop a program for the installation and replacement of emergency generators at critical facilities.</p> <p><b>Comment:</b> The City installed an emergency generator at City Hall in 2018. The City continues to assess the installation of emergency generators at critical facilities with a focus on the delivery of a new community center which would provide emergency shelter capabilities in the Belle Haven neighborhood. This new facility would provide back-up power options using solar and battery backups in addition to an emergency generator. All emergency generators are serviced monthly by the Public Works fleet section and a list of the age and condition of all generators has been developed.</p> <p>The City will carry over and modify the Action Item to maintain and replace emergency generators at critical facilities.</p>				MPK-15
<p><b>MP-29</b>—Continue to enforce and or comply with the State-mandated requirement that site-specific geologic reports be prepared for development proposals within Alquist-Priolo Earthquake Fault Zones and restrict the placement of structures for human occupancy.</p> <p><b>Comment:</b> The City complies with and enforces State mandated requirements. No properties within the City limits are within active fault zones.</p>	✓			
<p><b>MP-30</b>—Update as needed and enforce regulations concerning new construction (and major improvements to existing structures) within flood zones in order to be compliant with federal requirements and the National Flood Insurance Program.</p> <p><b>Comment:</b> The City continues to enforce regulations concerning new construction within flood zones complying with federal requirements. The City enforces stricter regulations with Ordinance 12.42.</p>	✓			
<p><b>G-1</b>—Consider participation in incentive-based programs such as the Community Rating System, Tree City, and StormReady.</p> <p><b>Comment:</b> The City of Menlo Park was certified to participate in the Community Rating System program and received Class 8 effective of October 1, 2020. The Arbor Day Foundation recognized the City of Menlo Park as a Tree City for 22 consecutive years and as a Tree Growth City for six years as of June 2021.</p> <p>This Action Item will be carried over and consolidated with MPK-5.</p>				MPK-5
<p><b>G-2</b>—Where feasible, implement a program to record high water marks following high-water events.</p> <p><b>Comment:</b> The City has an emergency flood response annex that has identified the appropriate response triggers. The City also monitors the San Francisquito Creek flood monitors which provide early warning when limits have been reached.</p>				
<p><b>G-3</b>—Provide incentives for eligible non-profits and private entities, including homeowners, to adapt to risks through structural and nonstructural retrofitting.</p> <p><b>Comment:</b> The City of Menlo Park has been recognized for performing floodplain management activities above and beyond the minimum requirements for the Federal Emergency Management Agency (FEMA) National Flood Insurance Program. Beginning this fall, Menlo Park residents and businesses located in the following flood zones could be eligible for a discount on their flood insurance premium: Flood zone A and AE: 10 percent discount; and Flood zone X: 5 percent discount.</p> <p>Menlo Park is an active member of the federal flood insurance program that provides flood insurance to residential and commercial structures in areas prone to inundation. The program also sets minimum standards for floodplain management which cities must follow to retain their membership status. Municipalities exceeding these standards may be eligible for flood insurance discounts through the Community Rating System (CRS). The City of Menlo Park has earned certification with a Class 8 rating. City's flood insurance webpage: <a href="https://www.menlopark.org/901/Flood-insurance">https://www.menlopark.org/901/Flood-insurance</a></p>				MPK-16

Action Item	Completed	Removed; No longer Feasible	Carried Over to Plan Update	
			Check if Yes	Action # in Update
<p><b>G-4</b>—Support the County-wide initiatives identified in Volume I of the hazard mitigation plan.</p> <p><b>Comment:</b> The City continues to partner with the County on all related hazard reduction, preparedness, and response efforts (CERT, County Disaster Preparedness Fair, Emergency Managers Association, JPA Emergency Service Council, etc.). These efforts will continue in the future through the efforts of the emergency management program. The City also participates as a member in the Disaster Service Committee, a local all hazard emergency management committee that deals with multi-jurisdictional hazards collectively. The City adopted Resolution No. 6339 on August 30, 2016, to approve an update to the Menlo Park Local Hazard Mitigation Plan Annex to the San Mateo County Hazard Mitigation Plan. This Action Item is repetitive. See Action Item MP-5.</p>				MPK-3
<p><b>G-5</b>—Actively participate in the plan maintenance protocols outlined in Volume I of the hazard mitigation plan.</p> <p><b>Comment:</b> The City continues to review the Local Hazard Mitigation Plan maintenance protocols and strives to assess its capabilities in achieving many of the tasks outlined in the plan; based on staffing and budget capabilities. Through department meetings, the local hazard mitigation projects are reviewed, and where budget allows, funds are directed toward such projects. This Action Item is repetitive. See Action Item MP-6.</p>				MPK-3

## 12.8 HAZARD MITIGATION ACTION PLAN

Table 12-14 lists the identified actions, which make up the hazard mitigation action plan for this jurisdiction. Table 12-15 identifies the priority for each action. Table 12-16 summarizes the mitigation actions by hazard of concern and mitigation type.

**Table 12-14. Hazard Mitigation Action Plan Matrix**

Benefits New or Existing Assets	Objectives Met	Lead Agency	Support Agency	Estimated Cost	Sources of Funding	Timeline <sup>a</sup>
<p><b>Action MPK-1</b>—Where appropriate, support retro-fitting in high hazard areas and prioritize those structures that have experienced repetitive losses. This may include, but not limited to, an inventory of city structures known to be at seismic risk.</p> <p><u>Hazards Mitigated:</u> Earthquake, Flood</p>						
Existing	6, 7, 9, 11, 13	Public Works	Community Development	High	Grant funding	Ongoing
<p><b>Action MPK-2</b>—Integrate the hazard mitigation plan into other plans, ordinances, and programs that dictate land use decisions within the community, including the General Plan Safety Element.</p> <p><u>Hazards Mitigated:</u> Flood, Earthquake, Climate Change, Sea Level Rise</p>						
New and Existing	2, 4, 6, 7	Community Development		Low	Staff time, General Fund	Ongoing
<p><b>Action MPK-3</b>—Integrate the hazard mitigation plan into other plans and programs that support infrastructure investments, such as the capital improvement program.</p> <p><u>Hazards Mitigated:</u> Flood, Earthquake, Climate Change, Drought, Sea Level Rise</p>						
New and Existing	1, 2, 4, 6, 7, 8, 13	Public Works		Medium	Staff time, General Funds, Grant funding	Ongoing
<p><b>Action MPK-4</b>—Support the County-wide initiatives and actively participate in the plan maintenance protocols outlined in Volume I of the hazard mitigation plan.</p> <p><u>Hazards Mitigated:</u> Flood, Earthquake, Drought, Climate Change, Sea Level Rise</p>						
New and Existing	1, 2, 3, 4, 5, 6, 7, 8, 9, 10, 11, 12, 13, 14	Public Works	Community Development	Low	Staff time, General Funds	Ongoing

Benefits New or Existing Assets	Objectives Met	Lead Agency	Support Agency	Estimated Cost	Sources of Funding	Timeline <sup>a</sup>
<b>Action MPK-5</b> —Continue to participate in Tree City USA, CRS, BCEGS, and maintain good standing and compliance under the National Flood Insurance Program (NFIP). This will be accomplished through the implementation of floodplain management programs that will, at a minimum, meet the requirements of the NFIP:						
<ul style="list-style-type: none"> <li>• Enforcement of the flood damage prevention ordinance</li> <li>• Participate in floodplain identification and mapping updates; and</li> <li>• Provide public assistance/information on floodplain requirements and impacts.</li> </ul> The City will also work towards obtaining a StormReady certification.						
<i>Hazards Mitigated:</i> Flood, Climate Change						
New and Existing	1, 2, 3, 4, 5, 6, 7, 8, 9, 10, 11, 13, 14	Public Works		Low	Grant funding, General Fund	Ongoing
<b>Action MPK-6</b> —Develop a post-disaster recovery plan, post-earthquake operation plan, and debris management plan.						
<i>Hazards Mitigated:</i> Flood, Earthquake						
New and Existing	1, 2, 6, 8, 9, 11	City of Menlo Park and Menlo Park Fire Protection District		Medium	Staff Time, General Funds, Emergency Management Performance Grants	Ongoing
<b>Action MPK-7</b> —Develop mitigation controls (continuity of government plans) and ensure force protection measures are in place in relation to vulnerable critical facilities within the city (e.g., police stations, fire stations, emergency operation center, City Hall, emergency shelters, etc.)						
<i>Hazards Mitigated:</i> Earthquake, Flood, Climate Change, Sea Level Rise						
New and Existing	6, 9, 13	City of Menlo Park	Menlo Park Fire Protection District	Medium	Grant funding	Short-term
<b>Action MPK-8</b> —Implement maintenance and storm preparedness plans that include the annual clearing of storm water drains and culverts, drainage ditches, and other waterways, such as the Atherton Channel and San Francisquito Creek, to maintain flood protection.						
<i>Hazards Mitigated:</i> Flood, Climate Change						
New and Existing	8,9	Public Works		Medium	Grant funding	Ongoing
<b>Action MPK-9</b> — Continue to coordinate with the San Francisquito Creek Joint Powers Authority on San Francisquito Creek and SAFER Bay flood control projects.						
<i>Hazards Mitigated:</i> Dam Failure, Flood, Landslide, Severe Weather, Climate Change, Sea Level Rise						
Existing	1, 4, 7, 8, 9, 10, 14	Public Works	San Francisquito Creek Joint Powers Authority	Medium	Staff Time, General Fund, Grant funding	Ongoing
<b>Action MPK-10</b> —Continue to coordinate with the California Coastal Conservancy and the U.S. Fish & Wildlife Service on the South Bay Salt Pond Restoration Project.						
<i>Hazards Mitigated:</i> Flood, Climate Change, Sea Level Rise						
Existing	1, 4, 7, 8, 9, 10, 14	California State Coastal Conservancy	Public Works	Low	Staff Time, General Fund	Ongoing
<b>Action MPK-11</b> —Upgrade the Chrysler Pump Station to improve flood protection in the Bayfront Area.						
<i>Hazards Mitigated:</i> Flood, Severe Weather, Climate Change, Sea Level Rise						
Existing	1, 6, 8,9	Public Works		Medium	Grant funding	Short-term
<b>Action MPK-12</b> —Produce hazards maps that take into account the impacts of flooding due to climate change.						
<i>Hazards Mitigated:</i> Flood, Climate Change, Severe Weather, Sea Level Rise						
New and Existing	1, 3, 4, 5, 8, 10, 11	Public Works	Information Technology	Low	Grant funding	Short-term

Benefits New or Existing Assets	Objectives Met	Lead Agency	Support Agency	Estimated Cost	Sources of Funding	Timeline <sup>a</sup>
<b>Action MPK-13</b> —Prepare a climate adaption and resiliency plan including, but not limited to, the following strategies:						
<ul style="list-style-type: none"> <li>Identify local risks of climate change (e.g., sea level rise, air quality, water supply, energy outages, vector control, extreme heat, increased social unrest)</li> <li>Identify what the City can do in the short-term while long-term planning is underway</li> <li>Identify in the long-term plan to include strategies that address further increases in global temperatures beyond 2040</li> <li>Conduct general engagement and education to develop the plan (city staff and the community)</li> <li>Address existing and future equity issues through research and engagement with low to moderate income community members that are likely to be most impacted and vulnerable to climate change</li> <li>Address mitigation and resiliency through capital improvement projects, city operations, and development projects</li> <li>Evaluate whether federal, state, and regional sea level rise district and San Francisquito Creek agencies holistically address Menlo Park’s local needs for climate adaptation/resiliency with a focus on equity</li> <li>Provide a roadmap for the City to follow over the next 10 years and/or beyond; and</li> <li>Revise policies and/or create programs to improve climate resilience.</li> </ul>						
<i>Hazards Mitigated:</i> Flood, Climate Change, Drought, Severe Weather, Sea Level Rise						
New and Existing	1, 2, 3, 4, 5, 8, 10, 14	City Manager’s Office	Public Works, Community Development	Low	Staff time, General Fund, Grant funding	Short-term
<b>Action MPK-14</b> —Continue to participate with the San Mateo County Flood and Sea Level Rise Resiliency District on flood control projects.						
<i>Hazards Mitigated:</i> Flood, Sea Level R						
Existing	1, 2, 3, 4, 5, 8, 10, 14	County of San Mateo	Public Works	Low	Staff Time, General Fund	Short-term
<b>Action MPK-15</b> —Develop a program for maintaining and replacing the emergency generators at critical facilities.						
<i>Hazards Mitigated:</i> Flood, Climate Change, Earthquake, Severe Weather						
New and Existing	6, 7, 8	Public Works		Medium	Grant funding	Ongoing
<b>Action MPK-16</b> —Provide incentives for eligible non-profits and private entities, including homeowners, to adapt to risks through structural and nonstructural retrofitting.						
<i>Hazards Mitigated:</i> Flood, Climate Change, Severe Weather, Earthquake, Dam Failure						
Existing	2, 3, 4, 5, 6, 7, 8, 9, 10, 13	City of Menlo Park		High	Grant funding	Ongoing
<b>Action MPK-17</b> —Update the City’s stormwater master plan to identify areas vulnerable to localized flooding and identify capital projects to mitigate those areas.						
<i>Hazards Mitigated:</i> Flood, Climate Change, Severe Weather						
Existing	1, 4, 6, 7, 8, 9, 13	Public Works		\$330,000	General Fund	Short-term
<b>Action MPK-18</b> —Develop a shoreline management plan to protect coastline from soil erosion and enhance the coastline with trails, parks, and wildlife refuge.						
<i>Hazards Mitigated:</i> Flood, Climate Change						
New	1, 4, 7, 8, 9, 13, 14	Public Works		Low/Medium	Staff time, General Fund, Grant funding	Medium-term
<b>Action MPK-19</b> —Review and update the City’s 2014 Emergency Operation Plan. Incorporate outreach, which may include, but not limited to, the City’s bi-annual resident survey and establish an annual report on LHMP.						
<i>Hazards Mitigated:</i> Flood, Earthquake, Climate Change, Dam Failure, Landslide/Mass Movements, Severe Weather, Drought, Tsunami, Sea Level Rise						
Existing	1, 2, 3, 4, 8, 9, 10, 11, 12	City of Menlo Park	Menlo Park Fire Protection District		Staff time	Short-term
<b>Action MPK-20</b> —Provide training opportunities for City staff to be certified floodplain managers.						
<i>Hazards Mitigated:</i> Flood						
New	1, 5, 7, 8, 9, 13	City of Menlo Park		Low	Staff time, General Fund	Ongoing

Benefits New or Existing Assets	Objectives Met	Lead Agency	Support Agency	Estimated Cost	Sources of Funding	Timeline <sup>a</sup>
<b>Action MPK-21</b> —Provide education to community members and City staff about the City’s 2030 Climate Action Plan goals and present strategies to achieve those goals.						
<u>Hazards Mitigated</u>	Climate Change, Sea Level Rise					
New and Existing	1, 2, 3, 4, 5, 6, 7, 8, 9, 10, 11, 12, 13, 14	City of Menlo Park		Low	Staff time, General Fund	Short-term
<b>Action MPK-22</b> —Develop an emergency water storage and supply project which may include, but is not limited to, a new underground reservoir to provide emergency water supply to residents during times of emergencies.						
<u>Hazards Mitigated</u>	Flood, Earthquake, Climate Change, Severe Weather, Drought					
New	1, 2, 4, 5, 6, 8, 9	Menlo Park Municipal Water		\$27M	Staff time, Water Fund, Loans	Medium-term (5-10 years)
<b>Action MPK-23</b> —Replace the roof on Reservoir 2, which is deteriorating and at the end of its life expectancy. The replacement would ensure continued public health protection, system reliability, and ensure the functionality of the existing emergency water storage.						
<u>Hazards Mitigated</u>	Earthquake, Climate Change, Severe Weather, Drought					
Existing	1, 4, 6, 8, 9, 13	Menlo Park Municipal Water		\$4.6M	Water Fund	Short-term
<b>Action MPK-24</b> —Plan, design, and implement the water infrastructure improvements recommended in the Water System Master Plan to upgrade infrastructure in the Menlo Park Municipal Water service area to meet fire flow demands.						
<u>Hazards Mitigated</u>	Severe Weather					
Existing	1, 4, 6, 8, 9, 13	Menlo Park Municipal Water		\$1.6M	Water Fund	Short-term
<b>Action MPK-25</b> —As part of the Water System Master Plan capital improvement projects, two water interconnection projects would provide alternative emergency water supply sources.						
<u>Hazards Mitigated</u>	Earthquake, Drought, Severe Weather					
New	1, 2, 4, 6, 8, 9, 13	Menlo Park Municipal Water		\$2M	Water Fund	Short-term
<b>Action MPK-26</b> —Incorporate consideration of the FEMA 100-year tide and sea level rise data and climate change-driven extreme storms into land use planning and shoreline development. This includes new policies by local jurisdictions, and County and City actions regarding their General Plans, Climate-related Plans, and the development applications.						
<u>Hazards Mitigated</u>	Flood, Climate Change, Sea Level Rise					
New and Existing	1, 2, 5, 6, 7, 8, 9, 13, 14	SMC Flood & Sea Level Rise Resiliency District	County and Menlo Park	Low	General Fund, Private Developers, City Capital Project Funding	Ongoing
<b>Action MPK-27</b> —Continue to identify and plan upgrades of utility systems, equipment, and critical facilities, including pump stations, generators, tide gates, stream gages, open channel, and culvert/pipeline infrastructure.						
<u>Hazards Mitigated</u>	Climate Change, Flood, Severe Weather					
New and Existing	2, 6, 7, 8	SMC Flood & Sea Level Rise Resiliency District	Menlo Park, County and San Mateo Resource Conservation District	Medium	Tax-Funded Flood Zones, Grant funding	Ongoing
<b>Action MPK-28</b> —Support green infrastructure projects that enhance resiliency to natural disasters and incorporate green design elements into hazard mitigation projects where feasible.						
<u>Hazards Mitigated</u>	Climate Change/Sea Level Rise, Landslide, Flood, Severe Weather, Drought, Sea Level Rise					
New and Existing	2, 6, 7, 8, 14	Menlo Park	SMC Flood & Sea Level Rise Resiliency District, and San Mateo Resource Conservation District	Medium	Tax-Funded Flood Zones, Property/Vehicle Fees, Stormwater Fees, Grant funding	Ongoing

Benefits New or Existing Assets	Objectives Met	Lead Agency	Support Agency	Estimated Cost	Sources of Funding	Timeline <sup>a</sup>
<b>Action MPK-29</b> —Identify and pursue strategies to enhance recycled water infrastructure planning/implementation in the vicinity of FSLRRD projects.						
<u>Hazards Mitigated</u> New and Existing	Drought 1, 6, 7,8	Menlo Park, SMC Flood & Sea Level Rise Resiliency District	County of San Mateo, San Mateo Resource Conservation District, and West Bay Sanitary Sewer District	Medium	Grant funding	Ongoing
<b>Action MPK-30</b> —Improve community response to flood emergencies in various ways, including but not limited to: - Upgrade and expand the countywide flood early warning system - Conduct community flood preparation, education, and recovery outreach.						
<u>Hazards Mitigated</u> New and Existing	Climate Change, Flood, Severe Weather 2, 3, 7, 8, 9, 10, 11	SMC Flood & Sea Level Rise Resiliency District	County and Menlo Park	Low	Grant funding	Short-term
<b>Action MPK-31</b> —Develop Emergency Action Plans for Bayfront Canal and Atherton Channel.						
<u>Hazards Mitigated</u> Existing	Climate Change, Flood, Severe Weather, Sea Level Rise 3, 4, 7, 8, 9,11	SMC Flood & Sea Level Rise Resiliency District	Redwood City, County of San Mateo, Menlo Park, and Atherton	Low	Grant funding	Long-term
<b>Action MPK-32</b> —Advance long-term resilience to sea level rise and extreme storms for the communities and critical assets along the San Francisco Bay shoreline south of Whipple Avenue to Marsh Road, as well as provide environmental, recreation, community/connectivity enhancements where possible.						
<u>Hazards Mitigated</u> New and Existing	Climate Change, Flood, Severe Weather, Sea Level Rise 6, 7, 8,14	SMC Flood & Sea Level Rise Resiliency District	Redwood City, County, and Menlo Park	High	Private Developers, Grant funding	Long-term
<b>Action MPK-33</b> —Complete construction and oversee ongoing operation, maintenance, and mitigation efforts for the Bayfront Canal and Atherton Channel Flood Protection and Ecosystem Restoration Project.						
<u>Hazards Mitigated</u> Existing	Flood, Severe Weather, Sea Level Rise 4, 7, 8	SMC Flood & Sea Level Rise Resiliency District	Redwood City, Menlo Park, Atherton, and County	Low	Grant funding, City Capital Project Funding	Short-term
<b>Action MPK-34</b> —Advance long-term resilience to sea level rise and extreme storms for the communities and critical assets adjacent to the San Francisquito Creek and nearby areas of the shoreline with the Cities of Menlo Park and East Palo Alto, as well as provide environmental, recreation, community/connectivity enhancements where possible.						
<u>Hazards Mitigated</u> New and Existing	Climate Change, Flood, Severe Weather, Sea Level Rise 4, 6, 7, 8, 10, 14	Menlo Park	Caltrans, and San Francisquito Creek Joint Powers Authority, San Mateo Resource Conservation District	Medium	Grant funding, Federal Grants (FEMA BRIC/HMGP), City Capital Project Funding	Long-term

a. Short-term = Completion within 5 years; Long-term = Completion within 10 years; Ongoing= Continuing new or existing program with no completion date

Acronyms used here are defined at the beginning of this volume.



**Table 12-15. Mitigation Action Priority**

Action #	# of Objectives Met	Benefits	Costs	Do Benefits Equal or Exceed Cost?	Is Project Eligible for Outside Funding?	Can Project Be Funded Under Existing Programs/Budgets?	Implementation Priority <sup>a</sup>	Outside Funding Source Pursuit Priority <sup>a</sup>	Social Equity Priority <sup>a</sup>
1	5	High	High	Yes	Yes	No	Medium	High	High
2	4	Medium	Low	Yes	No	Yes	High	Low	High
3	8	Medium	Low	Yes	No	Yes	High	Low	High
4	14	Medium	Low	Yes	No	Yes	High	Low	High
5	13	High	Low	Yes	No	Yes	High	Low	High
6	6	High	Medium	Yes	Yes	No	Medium	Medium	Medium
7	3	Medium	Medium	Yes	Yes	No	Medium	Medium	High
8	2	High	Medium	Yes	No	Yes	High	High	High
9	7	Medium	Medium	Yes	No	Yes	High	Low	Low
10	7	Medium	Medium	Yes	Yes	Yes	High	High	High
11	4	High	Medium	Yes	Yes	Yes	High	High	High
12	7	High	Low	Yes	No	Yes	High	High	High
13	8	Medium	Low	Yes	Yes	Yes	Medium	High	High
14	8	Medium	Low	Yes	No	Yes	High	Low	High
15	8	Low	High	No	No	No	Low	Low	Low
16	10	Low	Low	Yes	No	Yes	Low	Low	High
17	7	High	Medium	Yes	No	Yes	High	Low	High
18	7	Medium	Medium	Yes	Yes	No	Medium	Medium	High
19	9	Medium	Medium	Yes	Yes	Yes	Medium	Medium	High
20	6	Medium	Low	Yes	No	Yes	Medium	Low	Low
21	14	Medium	Low	Yes	No	Yes	Medium	Low	High
22	7	High	Medium	Yes	No	Yes	High	Low	High
23	6	Medium	Low	Yes	Yes	Yes	High	Low	High
24	6	High	Medium	Yes	Yes	Yes	High	High	High
25	7	Medium	Medium	Yes	Yes	Yes	High	Low	High
26	9	High	Low	Yes	Yes	Yes	High	High	High
27	4	High	Medium	Yes	Yes	Yes	High	High	High
28	5	Medium	Medium	Yes	Yes	Yes	High	Medium	Medium
29	4	Medium	Medium	Yes	Yes	Yes	High	Medium	Low
30	7	High	Low	Yes	Yes	Yes	High	Low	High
31	6	High	Low	Yes	Yes	Yes	High	Low	High
32	4	High	High	Yes	Yes	No	Medium	High	High
33	3	High	Low	Yes	Yes	Yes	High	Low	High
34	6	High	Medium	Yes	Yes	Yes	High	High	High

a. See the introduction to this volume for explanation of priorities.

**Table 12-16. Analysis of Mitigation Actions**

Hazard Type	Action Addressing Hazard, by Mitigation Type <sup>a</sup>							
	Prevention	Property Protection	Public Education & Awareness	Natural Resource Protection	Emergency Services	Structural Projects	Climate Resilience	Community Capacity Building
<b>High-Risk Hazards</b>								
<b>Flood</b>	MPK-2, 3, 4, 5, 7, 8, 9, 10, 12, 13, 14, 15, 16, 17, 18, 19, 20, 22, 26, 27, 28, 32, 33, 34	MPK-1, 2, 3, 7, 9, 11, 15, 16, 18, 26, 27, 28, 32, 34	MPK-5, 7, 12, 13, 16, 19, 30, 31	MPK-9, 10, 18, 26, 28, 32, 33, 34	MPK-4, 6, 7, 8, 11, 15, 19, 22, 27, 30, 31	MPK-2, 3, 5, 7, 9, 10, 11, 16, 17, 22, 27, 28, 33	MPK-2, 3, 5, 7, 8, 9, 10, 11, 12, 13, 14, 18, 26, 27, 28, 32, 33, 34	MPK-1, 2, 5, 7, 16, 20
<b>Earthquake</b>	MPK-2, 3, 4, 7, 15, 16, 19, 22	MPK-1, 2, 3, 7, 15, 16, 23	MPK-7, 16, 19		MPK-4, 6, 7, 15, 19, 22, 23, 25	MPK-2, 3, 7, 16, 22, 23, 25	MPK-1, 2, 3, 7	MPK-1, 2, 7, 16
<b>Sea Level Rise / Climate Change</b>	MPK-2, 3, 4, 5, 7, 8, 9, 10, 12, 13, 15, 16, 17, 18, 19, 22, 26, 27, 28, 32, 34	MPK-2, 3, 7, 9, 11, 15, 16, 18, 23, 26, 27, 28, 32, 33	MPK-5, 7, 12, 13, 16, 19, 21, 30, 31	MPK-9, 10, 18, 21, 26, 28, 32, 34	MPK-4, 7, 8, 11, 15, 19, 22, 23, 27, 28, 30, 31	MPK-2, 3, 5, 7, 9, 10, 11, 16, 17, 22, 23, 27, 28	MPK-2, 3, 5, 7, 8, 9, 10, 11, 12, 13, 18, 26, 27, 28, 32, 34	MPK-2, 3, 5, 7, 16
<b>Medium-Risk Hazards</b>								
<b>Severe Weather/ Extreme Weather</b>	MPK-9, 12, 13, 15, 16, 18, 19, 22, 24, 27, 28, 32, 33, 34	MPK-9, 11, 15, 18, 23, 24, 27, 28, 32, 34	MPK-12, 13, 19, 30, 33	MPK-9, 28, 32, 33, 34	MPK-11, 15, 19, 22, 23, 24, 25, 27, 28, 30, 31	MPK-9, 11, 16, 17, 22, 23, 24, 25, 27, 28, 33	MPK-9, 11, 12, 13, 27, 28, 32, 33, 34	MPK-16
<b>Low-Risk Hazards</b>								
<b>Landslide/ Mass Movements</b>	MPK-9, 19, 28	MPK-9, 28	MPK-19	MPK-9, 28	MPK-20, 28	MPK-9, 28	MPK-9, 28	
<b>Dam Failure</b>	MPK-9, 16, 19	MPK-9, 16	MPK-16, 19	MPK-9	MPK-19	MPK-9, 16	MPK-9	MPK-16
<b>Drought</b>	MPK-3, 4, 13, 19, 22, 28, 29	MPK-3, 23, 28, 29	MPK-13, 19	MPK-28	MPK-4, 19, 22, 23, 25, 28, 29	MPK-3, 22, 23, 25, 28, 29	MPK-3, 13, 28, 29	MPK-3
<b>Tsunami</b>			MPK-19		MPK-19			

a. See the introduction to this volume for explanation of mitigation types.

## 12.9 PUBLIC OUTREACH

Table 12-17 lists public outreach activities for this jurisdiction.

**Table 12-17. Local Public Outreach**

Local Outreach Activity	Date	Number of People Involved
City Council study session	Tentative August 2021	5 Councilmembers + Public
City of Menlo Park Weekly Digest E-Newsletter Article <a href="https://www.menlopark.org/Blog.aspx?IID=1747">https://www.menlopark.org/Blog.aspx?IID=1747</a>	5/24/2021	N/A
City of Menlo Park Weekly Digest E-Newsletter Article <a href="https://www.menlopark.org/Blog.aspx?IID=1706">https://www.menlopark.org/Blog.aspx?IID=1706</a>	4/5/2021	N/A
City of Menlo Park Weekly Digest E-Newsletter Article	Week of July 26	N/A

## 12.10 INFORMATION SOURCES USED FOR THIS ANNEX

The following technical reports, plans, and regulatory mechanisms were reviewed to provide information for this annex.







- **City of Menlo Park Municipal Code**—The municipal code was reviewed for the full capability assessment and for identifying opportunities for action plan integration.
- **City of Menlo Park Flood Damage Prevention Ordinance**—The flood damage prevention ordinance was reviewed for compliance with the National Flood Insurance Program.
- **City of Menlo Park 2030 Climate Action Plan**—The CAP outlines goals and strategies related to environmental protection and climate change.
- **City of Menlo Park General Plan**—This comprehensive planning document contains many components related to local hazard mitigation planning.
  - Open Space/Conservation, Noise and Safety Elements (Adopted May 21, 2013)
- **Association of Bay Area Governments**—Data used for growth management summary (Plan Bay Area 2040)
- **California Department of Finance**—Data used for growth management summary (Table E-5, Population and Housing Estimates).
- **Accela**—City of Menlo Park online permitting software used for collecting development records.
- **City of Menlo Park Emergency Operation Plan**—The Plan was reviewed to identify the need to update it.
- **Climate Emergency Resolution No. 6535**—The resolution shows political support on addressing climate change.
- **Climate and Sustainability Resolution No. 6493**—The resolution shows political support to support the implementation of climate change adaptation strategies.
- **Amend the 2030 Climate Action Plan Resolution No. 6621**—The resolution includes the scope of work for 2021 implementation of the climate action plan.
- **Public Works Mutual Aid Agreement Resolution No. 6547**—The resolution enters the City into San Mateo County operational area building safety inspection program mutual aid program.

The following outside resources and references were reviewed:

- **Hazard Mitigation Plan Annex Development Toolkit**—The toolkit was used to support the identification of past hazard events and noted vulnerabilities, the risk ranking, and the development of the mitigation action plan.
- **San Mateo County Flood and Sea Level Rise Resiliency District Hazard Mitigation Table**—Email correspondence with the District throughout Phase 3.

# Menlo Park

## Critical Facilities, 1 of 2

-  Food, Water, Shelter
-  Health and Medical
-  Safety and Security
-  Selected City
-  Incorporated Cities
-  County Boundary
-  Highways

Data Sources: ESRI Basemap,  
San Mateo Co., DHS HIFLD



0 0.5 1 2 Miles

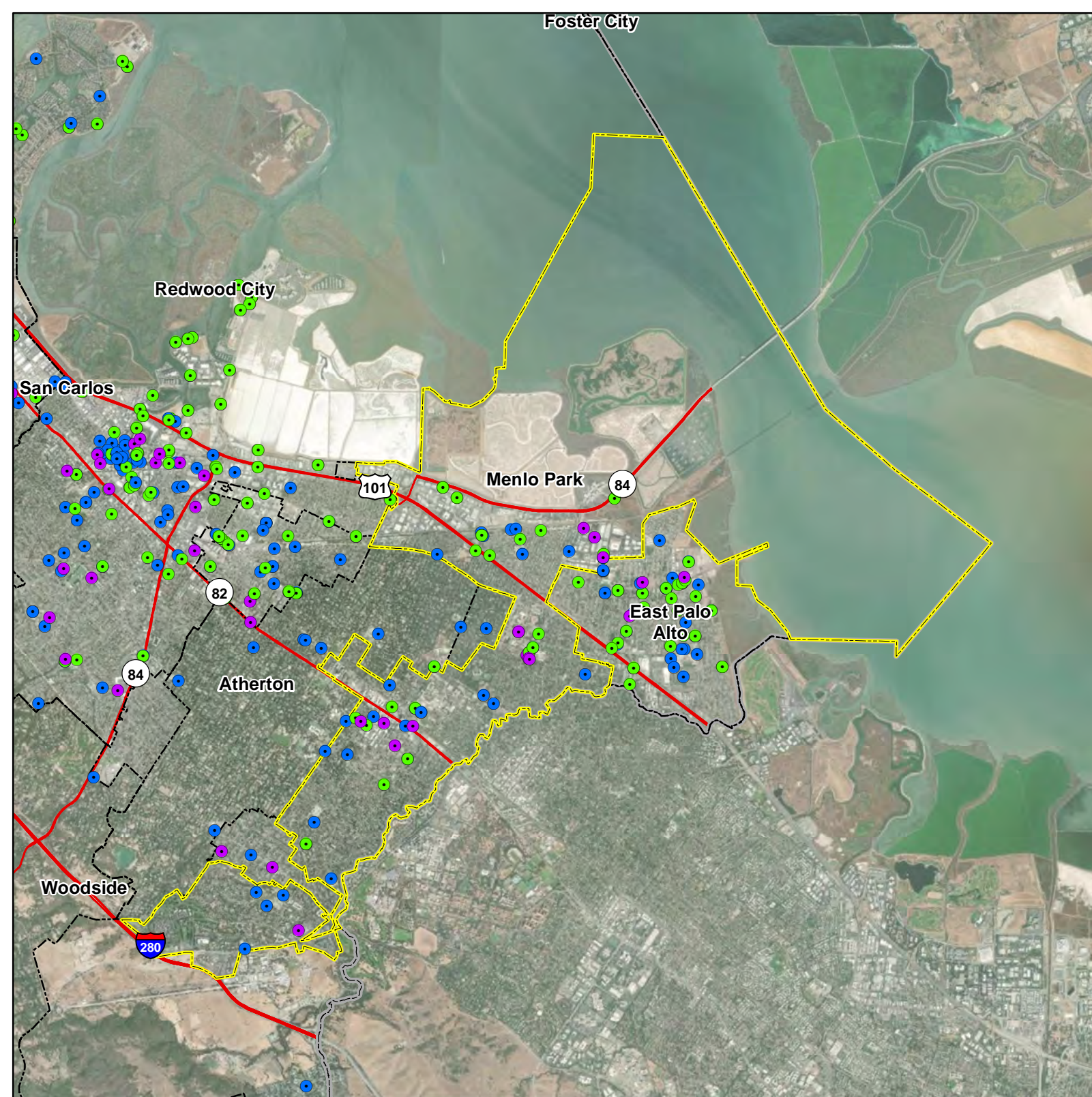

# Menlo Park

## Critical Facilities, 2 of 2

- Communications
- Energy
- Hazardous Materials
- Transportation
- ▭ Selected City
- ▭ Incorporated Cities
- ▭ County Boundary
- Highways

Data Sources: ESRI Basemap,  
San Mateo Co., DHS HIFLD









0 0.5 1 2 Miles



# Menlo Park

## Dam Failure Inundation Area Used for Risk Assessment

-  Inundation Area
-  Dam
-  Selected City
-  Incorporated Cities
-  County Boundary
-  Highways

Data Sources: ESRI Basemap,  
San Mateo Co., CA DWR









0 0.5 1 2 Miles



# Menlo Park

## NEHRP Soil Class

-  C (Dense soil/soft rock)
-  D (Stiff soil)
-  E (Soft clay)
-  Selected City
-  Incorporated Cities
-  County Boundary
-  Highways

Data Sources: ESRI Basemap,  
San Mateo Co., CGS



0 0.5 1 2 Miles

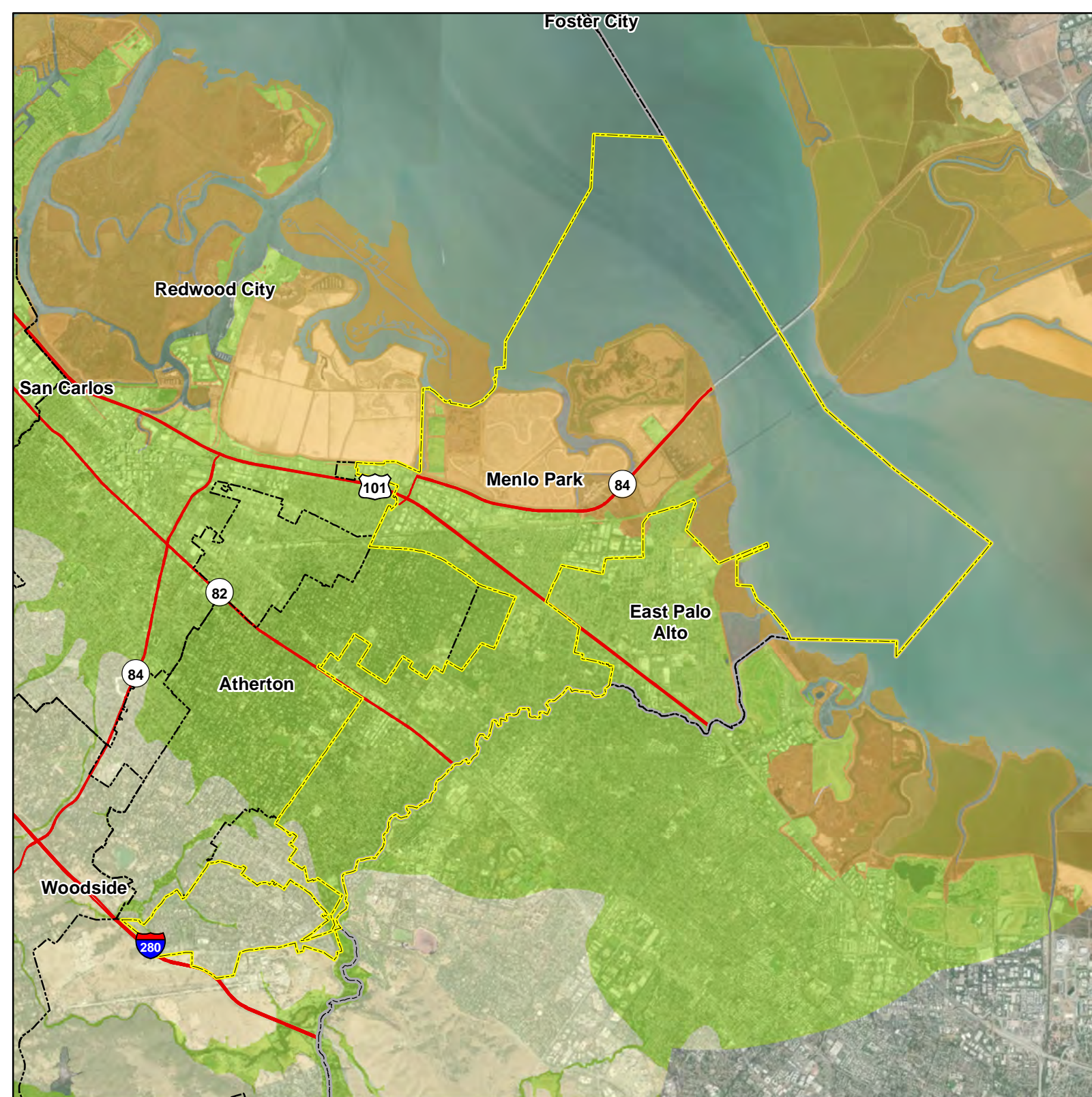

# Menlo Park

## Liquefaction Susceptibility

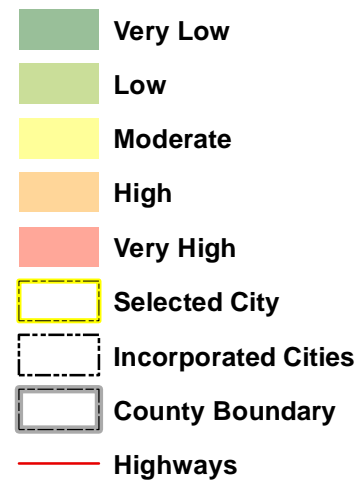

Data Sources: ESRI Basemap, San Mateo Co., ABAG (USGS)

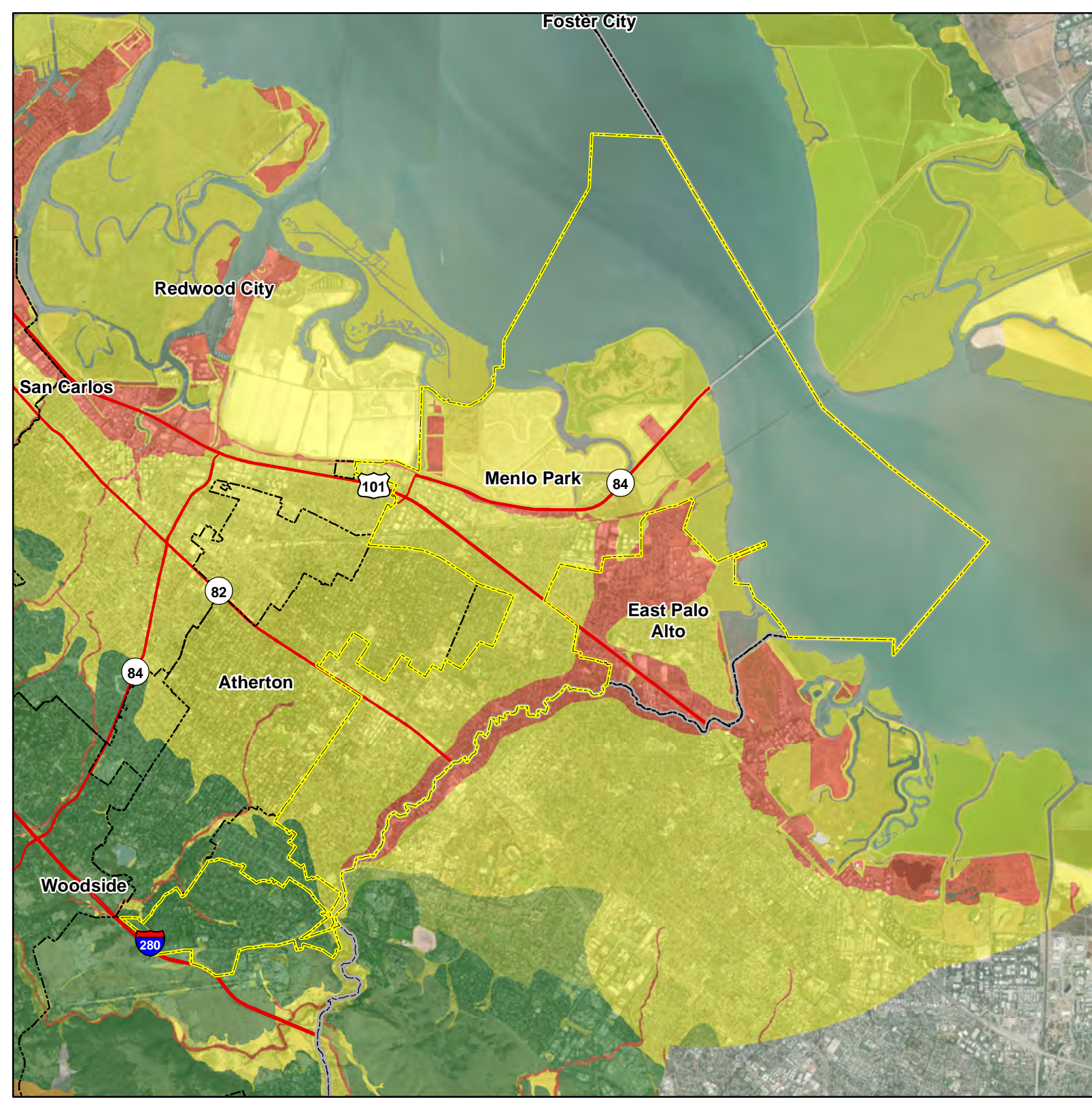
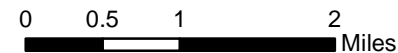



# Menlo Park

## Butano M6.93 Earthquake Scenario



- Mercalli Intensity Scale**
- VI (Strong/Light)
  - VII (Very Strong/Moderate)
  - Selected City
  - Incorporated Cities
  - County Boundary
  - Highways

Intensity scale described as:  
(perceived shaking / potential damage)



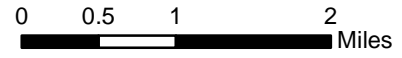

Data Sources: ESRI Basemap,  
San Mateo Co., USGS



# Menlo Park

## Monte Vista Shannon M7.14 Earthquake Scenario

### Mercalli Intensity Scale

-  VII (Very Strong/Moderate)
-  VIII (Severe/Moderate-Heavy)
-  Selected City
-  Incorporated Cities
-  County Boundary
-  Highways

Intensity scale described as:  
(perceived shaking / potential damage)

Data Sources: ESRI Basemap,  
San Mateo Co., USGS

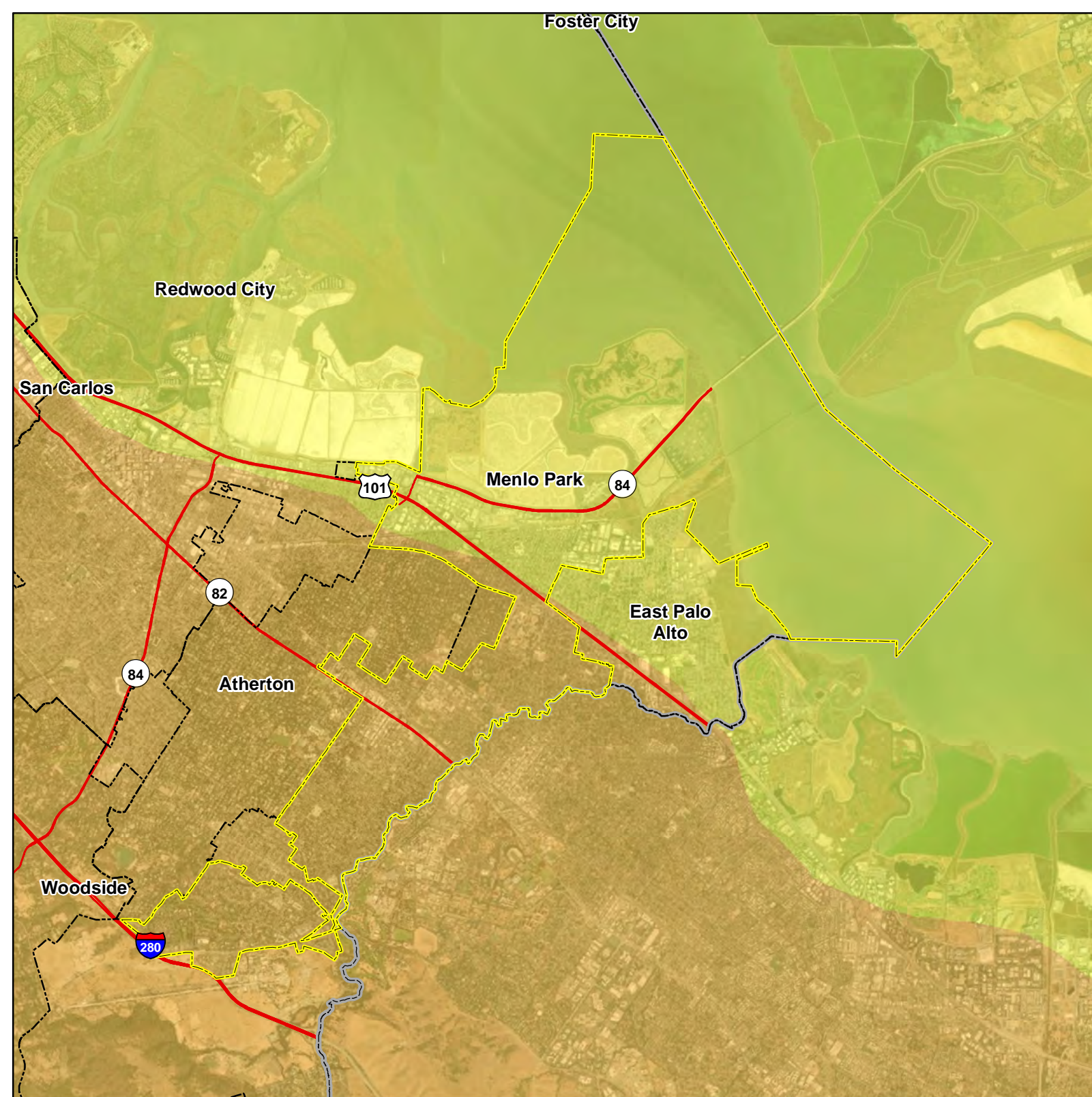
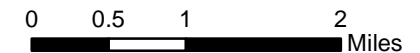

# Menlo Park

## 100-Year Probabilistic Earthquake Scenario

### Mercalli Intensity Scale

-  VII (Very Strong/Moderate)
-  VIII (Severe/Moderate-Heavy)
-  Selected City
-  Incorporated Cities
-  County Boundary
-  Highways

Intensity scale described as:  
(perceived shaking / potential damage)

Data Sources: ESRI Basemap,  
San Mateo Co., USGS



0 0.5 1 2 Miles

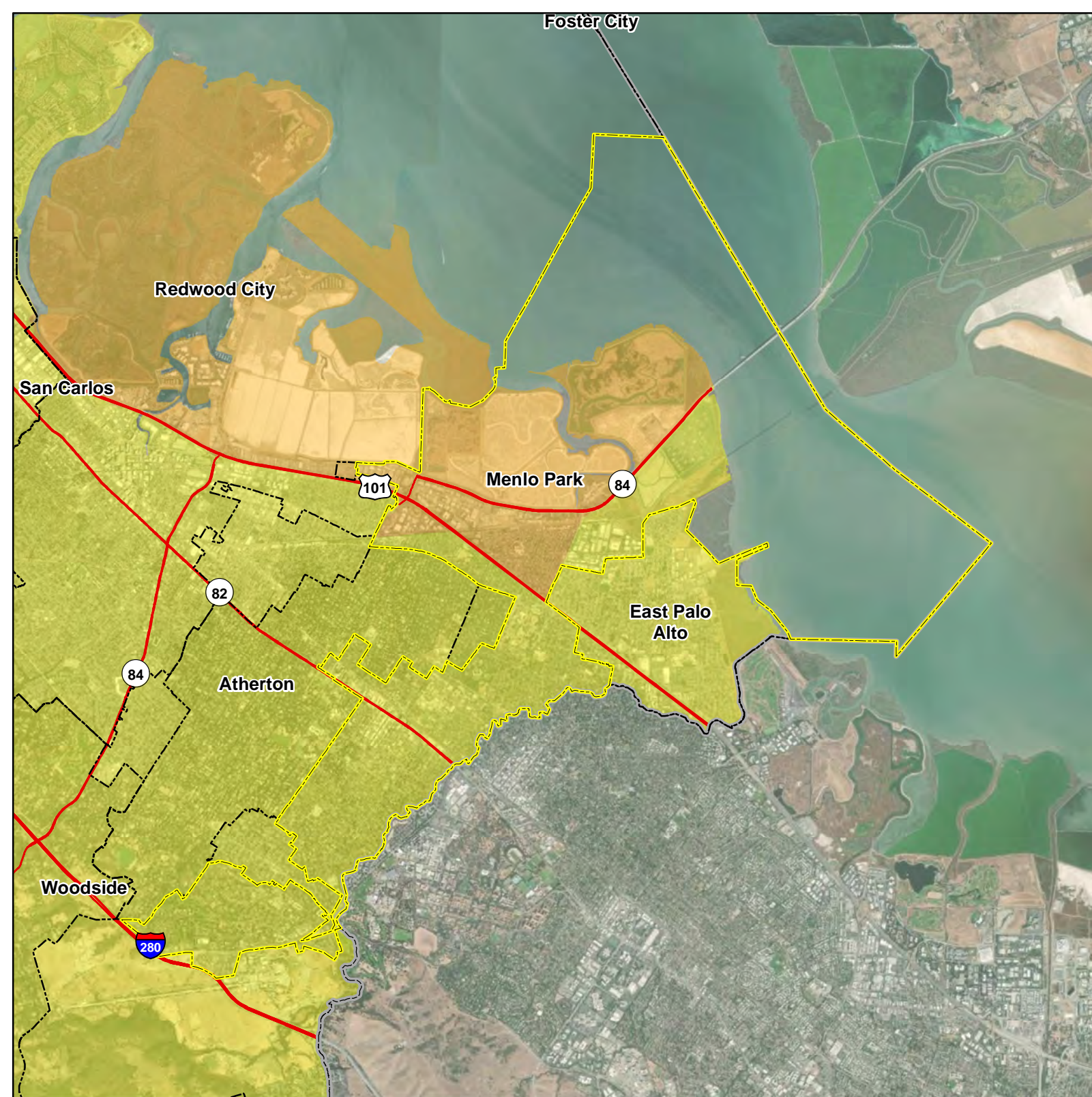

# Menlo Park

## San Andreas Peninsula M7.38 Earthquake Scenario

### Mercalli Intensity Scale

- VI (Strong/Light)
- VII (Very Strong/Moderate)
- VIII (Severe/Moderate-Heavy)
- Selected City
- Incorporated Cities
- County Boundary
- Highways

Intensity scale described as:  
(perceived shaking / potential damage)

Data Sources: ESRI Basemap,  
San Mateo Co., USGS



0 0.5 1 2 Miles

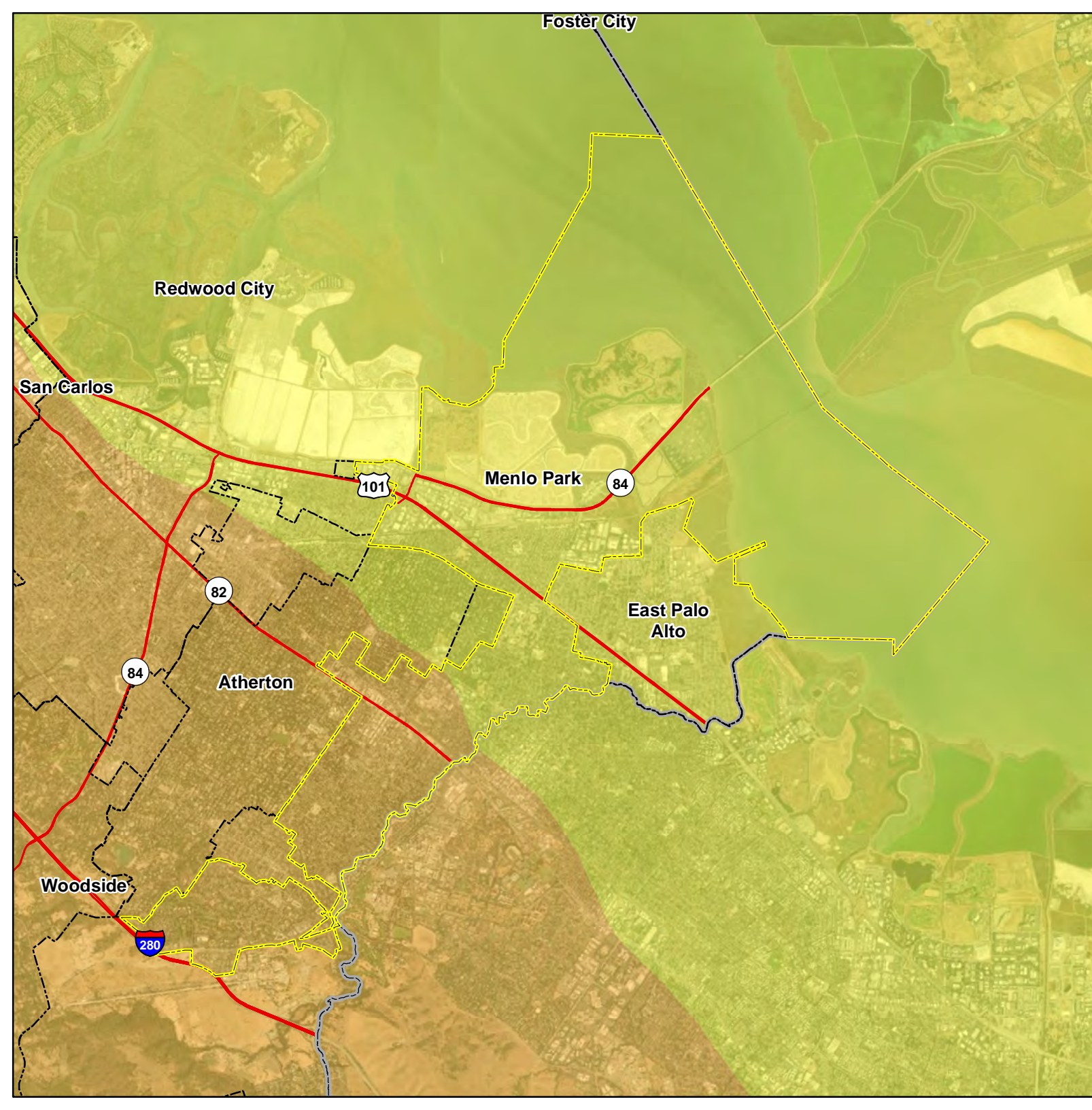

# Menlo Park

## San Gregorio North M7.44 Earthquake Scenario

### Mercalli Intensity Scale

- VI (Strong/Light)
- VII (Very Strong/Moderate)

- Selected City
- Incorporated Cities
- County Boundary
- Highways





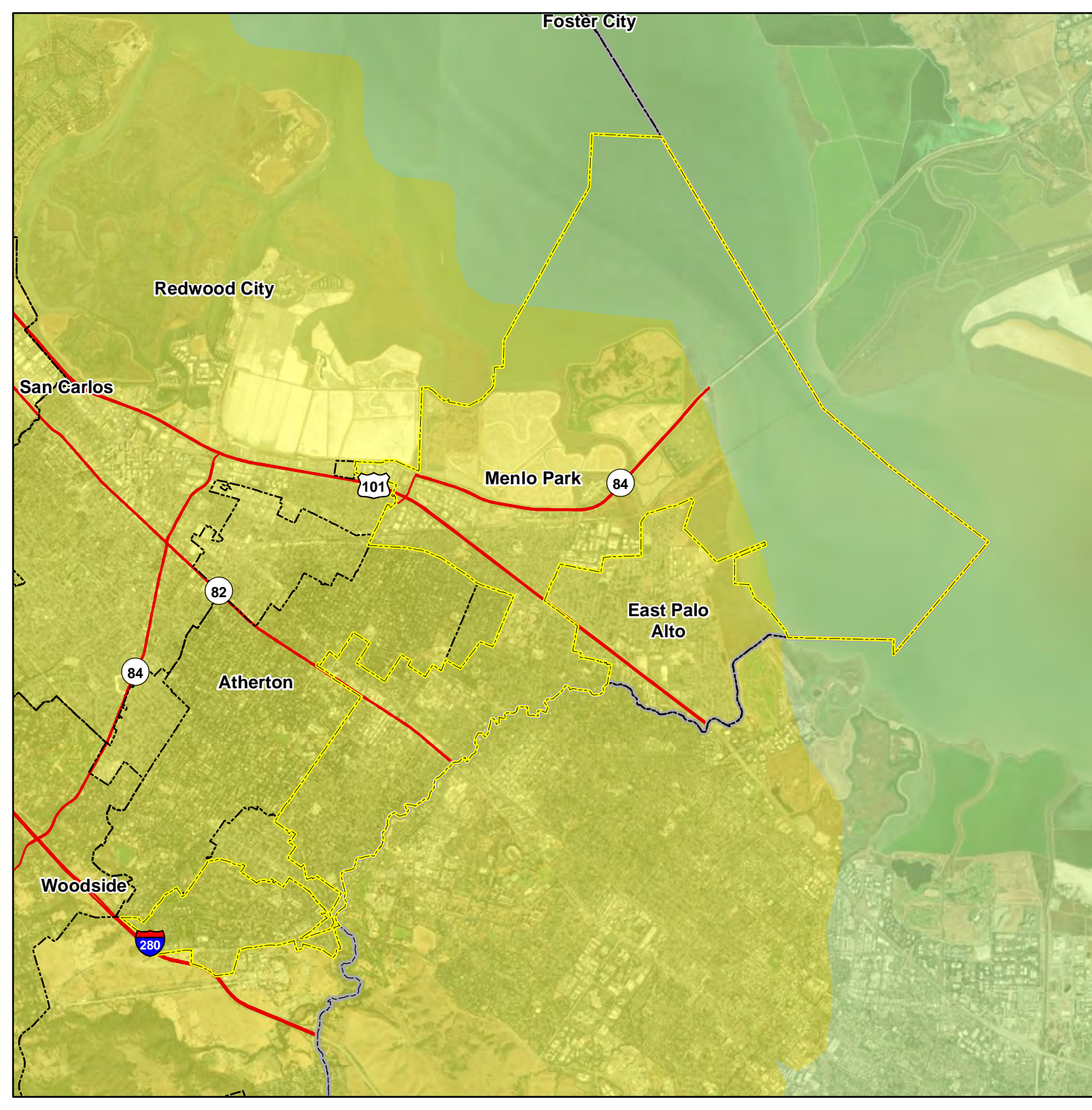

Intensity scale described as:  
(perceived shaking / potential damage)

Data Sources: ESRI Basemap,  
San Mateo Co., USGS



# Menlo Park

## FEMA Flood Hazard Areas

-  1% Annual Chance Flood (100-Year)
-  0.2% Annual Chance Flood (500-Year)
-  Selected City
-  Incorporated Cities
-  County Boundary
-  Highways

Data Sources: ESRI Basemap, San Mateo Co., FEMA



0 0.5 1 2 Miles



# Menlo Park

## Susceptibility to Deep-Seated Landslides

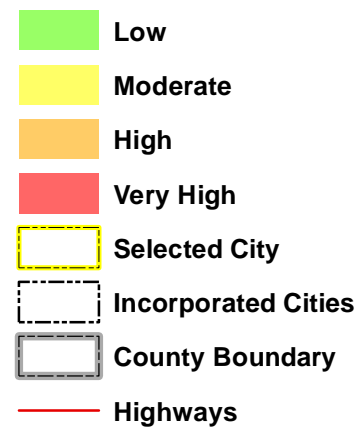



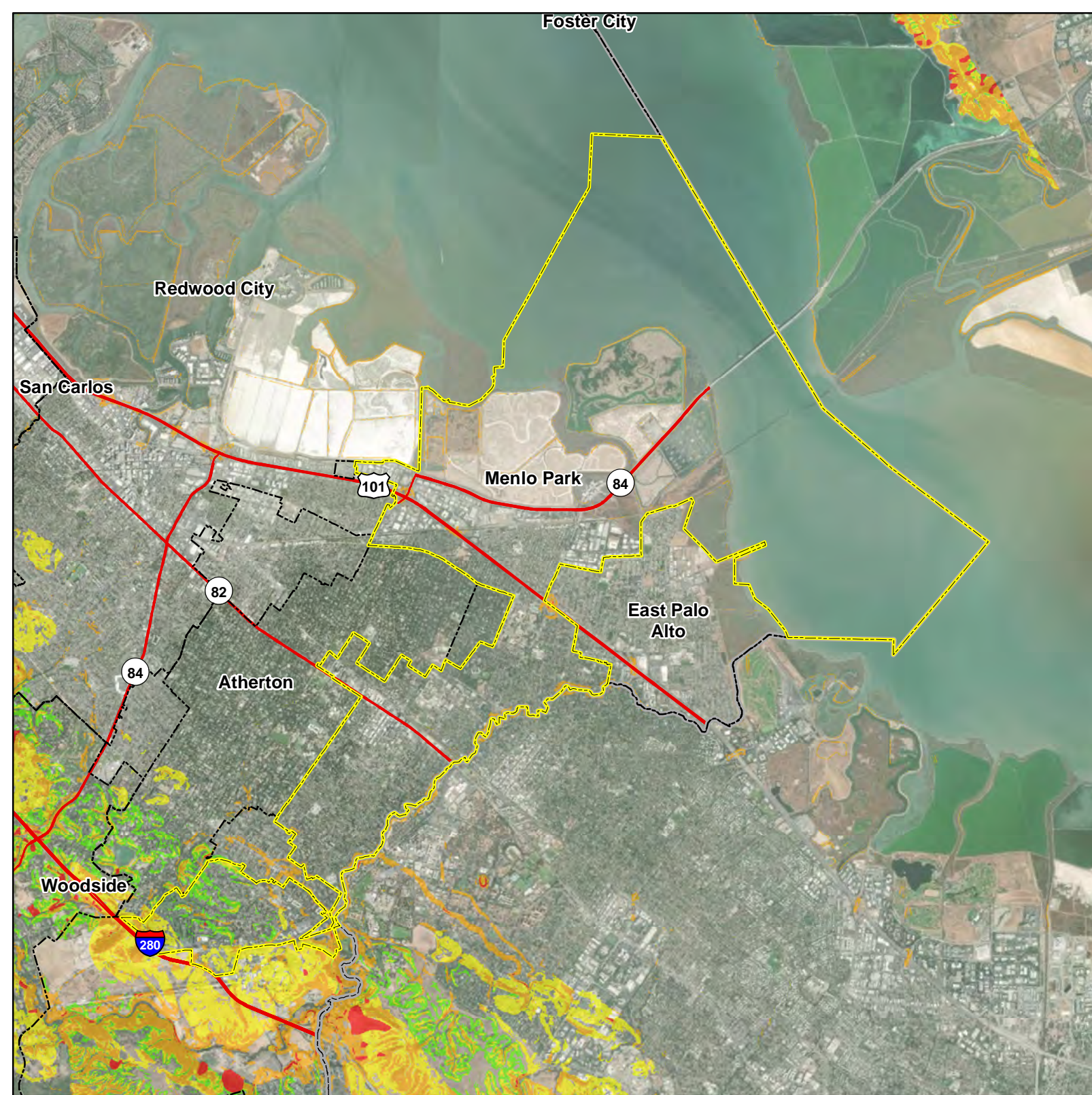
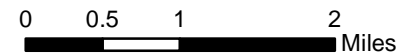

Data Sources: ESRI Basemap,  
San Mateo Co., CGS



# Menlo Park

## Sea Level Rise

-  Inundation Area
-  Selected City
-  Incorporated Cities
-  County Boundary
-  Highways

Inundation areas are a combination of Our Coast Our Future 200cm (6.6 feet) of SLR with 100-year storm for the Pacific Ocean coastline, and Adapting to Rising Tides 108 inches (9 feet) of SLR for the San Francisco Bay coastline.





Data Sources: ESRI Basemap, San Mateo Co., ART, OCOF





# Menlo Park

## Tsunami Hazard Areas

-  Hazard Areas
-  Selected City
-  Incorporated Cities
-  County Boundary
-  Highways

Data Sources: ESRI Basemap,  
San Mateo Co., CGS



0 0.5 1 2 Miles



# Menlo Park

## Wildfire Hazard Severity Zones

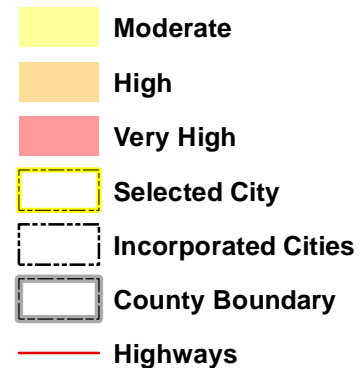

Data Sources: ESRI Basemap, San Mateo Co., CAL FIRE

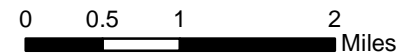



**Council Action Advised by August 31, 2021**

June 16, 2021

**TO: City Managers and City Clerks**

**RE: DESIGNATION OF VOTING DELEGATES AND ALTERNATES  
League of California Cities Annual Conference & Expo – September 22-24, 2021**

Cal Cities 2021 Annual Conference & Expo is scheduled for September 22-24, 2021 in Sacramento. An important part of the Annual Conference is the Annual Business Meeting (during General Assembly) on Friday, September 24. At this meeting, Cal Cities membership considers and acts on resolutions that establish Cal Cities policy.

In order to vote at the Annual Business Meeting, your city council must designate a voting delegate. Your city may also appoint up to two alternate voting delegates, one of whom may vote if the designated voting delegate is unable to serve in that capacity.

**Please complete the attached Voting Delegate form and return it to Cal Cities office no later than Wednesday, September 15. This will allow us time to establish voting delegate/alternate records prior to the conference.**

**Please note:** Our number one priority will continue to be the health and safety of participants. We are working closely with the Sacramento Convention Center to ensure that important protocols and cleaning procedures continue, and if necessary, are strengthened. Attendees can anticipate updates as the conference approaches.

- **Action by Council Required.** Consistent with Cal Cities bylaws, a city's voting delegate and up to two alternates must be designated by the city council. When completing the attached Voting Delegate form, please attach either a copy of the council resolution that reflects the council action taken, or have your city clerk or mayor sign the form affirming that the names provided are those selected by the city council. Please note that designating the voting delegate and alternates **must** be done by city council action and cannot be accomplished by individual action of the mayor or city manager alone.
- **Conference Registration Required.** The voting delegate and alternates must be registered to attend the conference. They need not register for the entire conference; they may register for Friday only. Conference registration will open mid-June at [www.cacities.org](http://www.cacities.org). In order to cast a vote, at least one voter must be present at the Business Meeting and in possession of the voting delegate card. Voting delegates and alternates need to pick up their conference badges before signing in and picking up the voting delegate card at the Voting Delegate Desk. This will enable them to receive the special sticker on their name badges that will admit them into the voting area during the Business Meeting.
- **Transferring Voting Card to Non-Designated Individuals Not Allowed.** The voting delegate card may be transferred freely between the voting delegate and alternates, but

*only* between the voting delegate and alternates. If the voting delegate and alternates find themselves unable to attend the Business Meeting, they may *not* transfer the voting card to another city official.

- **Seating Protocol during General Assembly.** At the Business Meeting, individuals with the voting card will sit in a separate area. Admission to this area will be limited to those individuals with a special sticker on their name badge identifying them as a voting delegate or alternate. If the voting delegate and alternates wish to sit together, they must sign in at the Voting Delegate Desk and obtain the special sticker on their badges.

The Voting Delegate Desk, located in the conference registration area of the Sacramento Convention Center, will be open at the following times: Wednesday, September 22, 8:00 a.m. – 6:00 p.m.; Thursday, September 23, 7:00 a.m. – 4:00 p.m.; and Friday, September 24, 7:30 a.m.– 11:30 a.m. The Voting Delegate Desk will also be open at the Business Meeting on Friday, but will be closed during roll calls and voting.

The voting procedures that will be used at the conference are attached to this memo. Please share these procedures and this memo with your council and especially with the individuals that your council designates as your city's voting delegate and alternates.

Once again, thank you for completing the voting delegate and alternate form and returning it to the League's office by Wednesday, September 15. If you have questions, please call Darla Yacub at (916) 658-8254.

Attachments:

- Annual Conference Voting Procedures
- Voting Delegate/Alternate Form



## Annual Conference Voting Procedures

1. **One City One Vote.** Each member city has a right to cast one vote on matters pertaining to Cal Cities policy.
2. **Designating a City Voting Representative.** Prior to the Annual Conference, each city council may designate a voting delegate and up to two alternates; these individuals are identified on the Voting Delegate Form provided to the Cal Cities Credentials Committee.
3. **Registering with the Credentials Committee.** The voting delegate, or alternates, may pick up the city's voting card at the Voting Delegate Desk in the conference registration area. Voting delegates and alternates must sign in at the Voting Delegate Desk. Here they will receive a special sticker on their name badge and thus be admitted to the voting area at the Business Meeting.
4. **Signing Initiated Resolution Petitions.** Only those individuals who are voting delegates (or alternates), and who have picked up their city's voting card by providing a signature to the Credentials Committee at the Voting Delegate Desk, may sign petitions to initiate a resolution.
5. **Voting.** To cast the city's vote, a city official must have in their possession the city's voting card and be registered with the Credentials Committee. The voting card may be transferred freely between the voting delegate and alternates, but may not be transferred to another city official who is neither a voting delegate or alternate.
6. **Voting Area at Business Meeting.** At the Business Meeting, individuals with a voting card will sit in a designated area. Admission will be limited to those individuals with a special sticker on their name badge identifying them as a voting delegate or alternate.
7. **Resolving Disputes.** In case of dispute, the Credentials Committee will determine the validity of signatures on petitioned resolutions and the right of a city official to vote at the Business Meeting.



**CITY:** Menlo Park

**2021 ANNUAL CONFERENCE  
VOTING DELEGATE/ALTERNATE FORM**

**Please complete this form and return it to Cal Cities office by Wednesday, September 15, 2021. Forms not sent by this deadline may be submitted to the Voting Delegate Desk located in the Annual Conference Registration Area. Your city council may designate one voting delegate and up to two alternates.**

To vote at the Annual Business Meeting (General Assembly), voting delegates and alternates must be designated by your city council. Please attach the council resolution as proof of designation. As an alternative, the Mayor or City Clerk may sign this form, affirming that the designation reflects the action taken by the council.

**Please note:** Voting delegates and alternates will be seated in a separate area at the Annual Business Meeting. Admission to this designated area will be limited to individuals (voting delegates and alternates) who are identified with a special sticker on their conference badge. This sticker can be obtained only at the Voting Delegate Desk.

**1. VOTING DELEGATE**

Name: \_\_\_\_\_

Title: \_\_\_\_\_

**2. VOTING DELEGATE - ALTERNATE**

Name: \_\_\_\_\_

Title: \_\_\_\_\_

**3. VOTING DELEGATE - ALTERNATE**

Name: \_\_\_\_\_

Title: \_\_\_\_\_

**PLEASE ATTACH COUNCIL RESOLUTION DESIGNATING VOTING DELEGATE AND ALTERNATES OR**

**ATTEST: I affirm that the information provided reflects action by the city council to designate the voting delegate and alternate(s).**

Name: \_\_\_\_\_

Email \_\_\_\_\_

Mayor or City Clerk \_\_\_\_\_  
(circle one) (signature)

Date \_\_\_\_\_ Phone \_\_\_\_\_

**Please complete and return by Wednesday, September 15, 2021 to:**  
Darla Yacub, Assistant to the Administrative Services Director  
E-mail: [dyacub@cacities.org](mailto:dyacub@cacities.org)  
Phone: (916) 658-8254