



**SPECIAL MEETING AGENDA – AMENDED**

**Date:** 9/21/2021  
**Time:** 5:00 p.m.  
**Location:** [Zoom.us/join](https://zoom.us/join) – ID# 998 8073 4930

This amended agenda removes item J2.

**NOVEL CORONAVIRUS, COVID-19, EMERGENCY ADVISORY NOTICE**

On March 19, 2020, the Governor ordered a statewide stay-at-home order calling on all individuals living in the State of California to stay at home or at their place of residence to slow the spread of the COVID-19 virus. Additionally, the Governor has temporarily suspended certain requirements of the Brown Act. For the duration of the shelter in place order, the following public meeting protocols will apply.

Teleconference meeting: All members of the City Council, city staff, applicants, and members of the public will be participating by teleconference. To promote social distancing while allowing essential governmental functions to continue, the Governor has temporarily waived portions of the open meetings act and rules pertaining to teleconference meetings. This meeting is conducted in compliance with the Governor Executive Order N-25-20 issued March 12, 2020, and supplemental Executive Order N-29-20 issued March 17, 2020.

- How to participate in the meeting
  - Submit a written comment online up to 1-hour before the meeting start time:  
[menlopark.org/publiccommentSeptember21](https://menlopark.org/publiccommentSeptember21)\*
  - Access the meeting real-time online at:  
[Zoom.us/join](https://zoom.us/join) – Meeting ID 998 8073 4930
  - Access the meeting real-time via telephone at:  
(669) 900-6833  
Meeting ID 998 8073 4930  
Press \*9 to raise hand to speak

\*Written public comments are accepted up to 1-hour before the meeting start time. Written messages are provided to the City Council at the appropriate time in their meeting.

- Watch meeting:
  - Cable television subscriber in Menlo Park, East Palo Alto, Atherton, and Palo Alto:  
Channel 26
  - Online:  
[menlopark.org/streaming](https://menlopark.org/streaming)

Note: City Council closed sessions are not broadcast online or on television and public participation is limited to the beginning of closed session.

Subject to Change: Given the current public health emergency and the rapidly evolving federal, state, county and local orders, the format of this meeting may be altered or the meeting may be canceled. You may check on the status of the meeting by visiting the City’s website [www.menlopark.org](https://www.menlopark.org). The instructions for logging on to the webinar and/or the access code is subject to change. If you have difficulty accessing the webinar, please check the latest online edition of the posted agenda for updated information ([menlopark.org/agenda](https://menlopark.org/agenda)).

According to City Council policy, all meetings of the City Council are to end by midnight unless there is a super majority vote taken by 11:00 p.m. to extend the meeting and identify the items to be considered after 11:00 p.m.

**Closed Session ([Zoom.us/join](https://zoom.us/join) – ID# 998 8073 4930)**

**A. Call To Order**

**B. Roll Call**

**C. Agenda Review**

Agenda Review provides advance notice to members of the public and City staff of any modifications to the agenda order and any requests from City Councilmembers under City Councilmember reports.

**D. Closed Session**

Public Comment on these items will be taken before adjourning to Closed Session.

**D1. CONFERENCE WITH LEGAL COUNSEL - EXISTING LITIGATION (Government Code § 54956.9)**

Sand Hill Townhouse Association vs. City of Menlo Park (Case No. 21-CLJ-02831)

Claimant: Sand Hill Townhouse Association

Agency Claimed Against: City of Menlo Park

**D2. Closed session conference with labor negotiators pursuant to Government Code §54957.6 regarding labor negotiations with the American Federation of State, County, and Municipal Employees Local 829 (AFSCME) and Confidential employees; Service Employees International Union Local 521 (SEIU); Menlo Park Police Sergeants Association (PSA); Menlo Park Police Officers' Association (POA) and Confidential employees; unrepresented management; City Attorney and; City Manager**

Attendees: City Manager Starla Jerome-Robinson, Assistant City Manager Nick Pegueros, City Attorney Nira F. Doherty, Legal Counsel Charles Sakai, Interim Human Resources Manager Kristen Strubbe

**D3. Closed session conference pursuant to Government Code §54957(b)(1) regarding public employee performance evaluation of the City Attorney**

**E. Adjournment**

**Regular Session ([Zoom.us/join](https://zoom.us/join) – ID# 998 8073 4930)**

**F. Call To Order**

**G. Roll Call**

## H. Study Session

- H1. Presentation on California Senate Bill 1383 implementation to reduce short-lived climate pollutants and provide direction to prioritize City resources to meet implementation deadlines ([Staff Report #21-181-CC](#)) ([Presentation](#))

## I. Advisory Body Vacancies and Appointments

- I1. Consider applicants and make appointments to fill vacancies on the Finance and Audit Committee and Library Commission ([Staff Report #21-177-CC](#))

## J. Consent Calendar

- J1. Accept the City Council meeting minutes for August 31, 2021 ([Attachment](#))
- ~~J2. Approve and appropriate \$10,000 for seed money to support the newly formed Menlo Park Sister Cities Association and ongoing sister cities program ([Staff Report #21-179-CC](#))~~
- J3. Adopt Resolution No. 6654 approving the funding agreement with Hibiscus Properties for the construction of raised median islands on Chilco Street and authorizing the city manager to execute the funding agreement ([Staff Report #21-163-CC](#)) – **continued from August 31, 2021**
- J4. Adopt Resolution No. 6668 authorizing the city manager to rescind the portions of Emergency Order No. 2 in Fall 2021 related to the Arrillaga Family Gymnasium, City Council Chambers, City Hall, and Arrillaga Family Gymnastics Center ([Staff Report #21-183-CC](#))

## Recess

## K. Public Hearing

- K1. Ordinance No. 1078 repealing and replacing Menlo Park Municipal Code Section 16.86.025 ([Staff Report #21-186-CC](#))

## L. Regular Business

- L1. Adopt Resolution No. 6663 to approve permanent installation of the Belle Haven neighborhood traffic management plan ([Staff Report #21-173-CC](#)) ([Presentation](#)) – **continued from September 14, 2021**

[Web form public comment on item L1.](#)

- L2. Authorize the city manager to reactivate the gymnastics program ([Staff Report #21-182-CC](#)) ([Presentation](#))

[Web form public comment on item L2.](#)

- L3. Adopt the Transportation Management Association feasibility study final report ([Staff Report #21-184-CC](#)) ([Presentation](#))
- L4. Adopt resolution amending the City Council approved salary schedule effective September 21, 2021

([Staff Report #21-187-CC](#))

- L5. Direction on drafting an ordinance and ballot measure for City Council consideration on preserving park land ([Staff Report #21-185-CC](#)) ([Presentation](#))

[Web form public comment on item L5.](#)

## **M. Informational Items**

- M1. City Council agenda topics: October 2021 ([Staff Report #21-178-CC](#))
- M2. 2021 priorities and work plan quarterly report as of July 31 ([Staff Report #21-180-CC](#))

[Web form public comment on item M2.](#)

## **N. City Manager's Report**

## **O. City Councilmember Reports**

## **P. Adjournment**

At every regular meeting of the City Council, in addition to the public comment period where the public shall have the right to address the City Council on any matters of public interest not listed on the agenda, members of the public have the right to directly address the Council on any item listed on the agenda at a time designated by the chair, either before or during the City Council's consideration of the item.

At every special meeting of the City Council, members of the public have the right to directly address the City Council on any item listed on the agenda at a time designated by the chair, either before or during consideration of the item. For appeal hearings, appellant and applicant shall each have 10 minutes for presentations.

If you challenge any of the items listed on this agenda in court, you may be limited to raising only those issues you or someone else raised at the public hearing described in this notice, or in written correspondence delivered to the City of Menlo Park at, or prior to, the public hearing.

Any writing that is distributed to a majority of the City Council by any person in connection with an agenda item is a public record (subject to any exemption under the Public Records Act) and is available by request by emailing the city clerk at [jaherren@menlopark.org](mailto:jaherren@menlopark.org). Persons with disabilities, who require auxiliary aids or services in attending or participating in City Council meetings, may call the City Clerk's Office at 650-330-6620.

Agendas are posted in accordance with Government Code Section 54954.2(a) or Section 54956. Members of the public can view electronic agendas and staff reports by accessing the City website at [menlopark.org/agenda](http://menlopark.org/agenda) and can receive email notification of agenda and staff report postings by subscribing to the "Notify Me" service at [menlopark.org/notifyme](http://menlopark.org/notifyme). Agendas and staff reports may also be obtained by contacting City Clerk at 650-330-6620. (Posted: 9/16/2021)



## STAFF REPORT

### City Council

Meeting Date:

9/21/2021

Staff Report Number:

21-181-CC

Study Session:

**Presentation on California Senate Bill 1383 implementation to reduce short-lived climate pollutants and provide direction to prioritize City resources to meet implementation deadlines**

### Recommendation

City staff recommends that City Council receive a presentation on California Senate Bill 1383 (SB 1383) to reduce short-lived climate pollutants and provide direction to prioritize City resources for SB 1383 implementation including the following City Council approvals:

- An ordinance amending Menlo Park Municipal Code as necessary to implement SB 1383 effective January 1, 2022;
- A resolution joining a multi-agency memorandum of understanding (MOU) with South Bayside Waste Management Authority's (SBWMA) to help implement SB 1383;
- A resolution approving an MOU with San Mateo County to establish the food recovery program component of SB 1383; and
- A resolution amending the Recology franchise agreement for SB 1383 outreach and education for noncompliant parties.

### Policy Issues

On November 3, 2020, SB 1383 Short-Lived Climate Pollutants regulations took effect requiring cities to reduce greenhouse gas emissions in California. Staff seek direction on compliance issues related to new regulations promulgated by CalRecycle as mandated by SB 1383.

### Background

The City has taken numerous actions to address climate change. Menlo Park Municipal Code Section 16.43.140 is a green and sustainable building requirement, which requires developers to submit zero waste management plans to showcase how the project would reduce waste during the construction and occupancy phase. In 2017, City Council adopted the Community Zero Waste Plan, which defined zero waste as diversion of 90 percent of waste through recycling or composting programs. City Council adopted Resolution No. 6535, a separate and complimentary action boosting the importance of SB 1383, which declares a climate emergency and prioritized development of an aggressive climate action plan (CAP.) While not directly related to the highest priorities in the CAP, SB 1383 is a mandate to reduce greenhouse gases resulting from landfill waste throughout the state.

In September 2016, SB 1383 (Lara, Chapter 395, Statutes of 2016) established statewide methane emissions reduction targets in an effort to reduce emissions of short-lived climate pollutants (food scraps, yard debris, paper products, etc.) in various sectors of California's economy. It includes statewide goals to reduce the disposal of organic waste and recover edible food for human consumption. The goal to reduce

organic waste by 50 percent by January 1, 2020 and by 75 percent by January 1, 2025.

The intent and purpose of SB 1383 is to:

- Reduce landfill waste and pollution;
- Fight against climate change;
- Reduce and recover food from landfill to feed those in need; and
- Recycle organic materials into new products.

According to CalRecycle, landfills are the third largest source of methane in California. When organics and compostable materials are thrown in the landfill, they are broken down without oxygen. As a byproduct of the decomposition, methane is emitted into the atmosphere. Methane is 84 times more potent than carbon dioxide and is one of most potent greenhouse gases. As a result, organic waste in landfills produces 20 percent of the state's methane. On a local scale, 71 percent of the landfilled materials in San Mateo County are organic materials. Therefore, it is important for organic materials to be disposed of in the organics collection where they can be turned into compost or to create programs to collect surplus food for people in need to eat.

### **Analysis**

To accomplish statewide goals, the SB 1383 regulations include prescriptive requirements for jurisdictions related to recycling and organics collection, inspection, and enforcement policies and programs and edible food recovery. The City of Menlo Park is a SBWMA member agency and proactively collaborates closely with CalRecycle as well as regional partner agencies, including the SBWMA, Recology of San Mateo County, and the County of San Mateo, to implement SB 1383 programs in accordance with state guidelines and requirements. SBWMA and its member agencies must comply with nearly all SB 1383 requirements by January 1, 2022, with the significant exception that enforcement penalties against generators (i.e., customers) do not need to be imposed by the City before January 1, 2024.

The purpose of the study session is to provide information to the City Council on the requirements of SB 1383 and provide an overview of the next steps that will be required as well as the resources in the form of budget, solid waste rate adjustments or personnel that will likely be requested during this implementation period and beyond.

CalRecycle regulations to meet the SB 1383 targets will have a significant impact on the solid waste services provided throughout the State, in San Mateo County, the SBWMA service area and in Menlo Park specifically. Attachment A highlights the important requirements for jurisdiction compliance. The following sections briefly describe each direction needed from City Council to prioritize City resources for SB 1383 implementation.

### **SB 1383 required Municipal Code amendments**

Cities are required to adopt an enforceable ordinance to implement all requirements of SB 1383, including inspection and compliance enforcement as to generators of waste and haulers. CalRecycle provided a model ordinance, which the SBWMA has adapted for use by its member agencies.

In addition, the regulations also specifically require enforcement of certain CalGreen building standards and portions of the state's Model Water Efficiency Landscape Ordinance (MWELo.) As obligated by other state laws, the City has already adopted the CalGreen building code and has adopted a water efficient landscaping ordinance at least as strict as the MWELo, and therefore already is in compliance with these

requirements. However, City staff may need to amend the purchasing policy ordinance to include purchasing recycled-content paper products.

All departments in a jurisdiction that make paper purchases are required to purchase and keep purchase records for paper products that contain postconsumer recycled content and are recyclable. All paper purchases must contain 30 percent postconsumer recycled content, when available at no greater cost than non-recycled products and the products must be recyclable. Finally, the City must require vendors to certify postconsumer content and recyclability claims. For the purpose of SB 1383, "paper products" includes all types of traditional paper (copy paper, note pads, etc.) as well as janitorial supplies, cartons, wrapping, packaging, file folders, corrugated boxes, tissue and towels.

SB 1383 also require cities to meet an annual procurement target quantity (based on population) of recovered organic waste product, such as compost, mulch, renewable energy (for transportation fuel, heat and electricity), and electricity from biomass conversion.

Currently, the San Mateo County Office of Sustainability estimates that if this requirement were to be fulfilled only with finished compost, the service area procurement requirement is over 36,000 tons of compost per year with Menlo Park's procurement target at over 1,600 tons (81 truckloads) of compost. The procured compost does not need to be utilized or placed within the City limits to satisfy the requirements of SB 1383.

#### SBWMA MOU for assistance with implementing SB 1383

SBWMA is a Joint Powers Authority that operates collectively to provide our community's solid waste collection and programming and joint ownership of the Shoreway Environmental Center. SBWMA will assist member agencies to collectively address compliance requirements while also providing public education. SBWMA has hired a full-time staff person to assist member agencies with implementation and reporting for SB 1383.

As part of SB 1383 regulations, the City must address separation and diversion of organic waste via one of several permitted alternatives. The current waste collection service uses a three-bin system, which meets the requirements of SB 1383 for source separation. However, single family homes will be required to subscribe to and participate in organics curbside collection service. Multifamily complexes and businesses will be required to either subscribe to and participate in organics curbside collection or to self-haul organic waste. Businesses are required to annually and as needed educate employees, contractors, tenants, and customers regarding how to properly sort organic material into the correct containers.

Approximately 250 residential and 640 commercial accounts (multifamily and businesses) are not subscribed to Recology's organics collection service. For single-family homes, their monthly garbage service rates include recycling and organic services. Therefore, adding an organic bin is at no additional cost to them. The City has a non-exclusive agreement with Recology to collect organics on commercial properties. As a result, the number of commercial accounts may be lower as some properties may be backhauling organics.

The SBWMA board of directors approved the SBWMA SB 1383 compliance plan (Attachment B) November 19, 2020, which outlined anticipated responsibilities between the SBWMA and its member agencies. As detailed in the compliance plan, the SBWMA will take on a significant portion of the SB 1383 program responsibilities. The SBWMA drafted an Implementation of SB 1383 MOU detailing the roles and responsibilities of the SBWMA and its member agencies based on the SB 1383 program implementation and management requirements identified in the law.

The City is required to maintain an implementation record regarding SB 1383 compliance. It is anticipated that SBWMA staff will be heavily involved in record-keeping on a regional basis as they are now for recycling reporting. The MOU with SBWMA would include this scope of work.

San Mateo County MOU for establishing an edible food recovery program

San Mateo County is a proactive partner in several collective County-wide programs associated with Solid Waste and specifically addresses the edible food waste recovery element of SB 1383 at a regional level as well as potential partnership in the procurement requirement.

SB 1383 requires California to recover 20 percent of edible food that would otherwise be sent to landfills, to feed people in need by 2025. Jurisdictions need to establish food recovery programs and strengthen their existing food recovery networks, edible food generators arrange to recover the maximum amount of their edible food that would otherwise go to landfills.

Tier One Commercial Generators (supermarkets, grocery stores, food service providers, food distributors and wholesale vendors) would need to comply by January 1, 2022. Menlo Park has approximately 19 Tier One Commercial Generators. Tier Two Commercial Generators (large restaurants, hotels, health facilities, event venues, local education agency with on-site food facility and events) must comply by January 1, 2024. Menlo Park has approximately 18 Tier Two Commercial Generators.

Recology franchise agreement amendment for SB 1838 education

The City is required to conduct outreach and education to all affected parties, including generators, haulers, facilities, edible food recovery organizations, and municipal departments. The City's franchised waste hauler, has already started working to educate customers through Waste Zero Specialists and will work with the City and the SBWMA to meet compliance with new regulations. The amendment would include negotiating changes to collection and processing agreements, negotiating cost structure for new services, and providing waivers to eligible generators.

SB 1383 compliance and monitoring

Nearly all of the programs outlined in SB 1383 are required to be in place by January 1, 2022 or the City may be subject to enforcement action by CalRecycle; this includes requirements that the City inspect and enforce compliance against covered entities (residential and commercial customers.) Before January 1, 2024, the City must provide information on compliance to individuals and businesses that violate waste separation requirements and other requirements under the SB 1383. After that period, violations are subject to penalties.

Despite the support of the various agreements with partner agencies, the state will ultimately continue to hold the City responsible for compliance with SB 1383. As a result, the partnerships between all involved parties are important. City staff would need to submit a compliance report to CalRecycle in the first half of 2022.

SB 1383 authorizes local jurisdictions to charge fees to recover the costs incurred in complying with the regulations. Compliance with SB 1383 will most certainly result in increased costs through rate increases to residents, businesses and the City for education, outreach, organic waste product and recycled content paper procurement, inspections, enforcement, and establishing and/or expanding the edible food program for the community.

The compliance plan (Attachment B) was prepared in November 2020 for the SBWMA by consultant HF&H. A preliminary cost analysis on Page 14 of the report identified a likely rate impact of 0.3 percent to 2.6 percent for compliance that utilized Shoreway technology (O2E) to help meet diversion targets. This



technology has just entered the Pilot phase April 15, and it is not yet known whether it can be successfully scaled. If the new technology is not successful in meeting the compliance targets, the rate impact of implementing SB 1383 requirements is estimated to be as much as 7.1 percent. Given the variables and a likely hybrid approach to procurement, it is most likely that the rate impact will fall somewhere in the middle of the range.

Over and above the direct rate impacts, on Page 26 of the report is an analysis of the likely additional staff time that will be required of City staff to conduct enforcement that cannot be delegated to the County, SBMWA or Recology. For a medium-size agency, such as City of Menlo Park, it is anticipated that undelegatable tasks would require 0.1 to 0.3 full time employee (approximately 4 to 12 hours per week on average.) This would mean the addition of these activities will require that other staff work is prioritized or additional staff time be added.

The SBWMA has hired one full-time program manager II to manage the SB 1383 program on the participating member agency's behalf. Additional costs shall be jointly shared by member agencies through the garbage tipping fee rate. Budget changes related to the MOU will be integrated into the Agency's regular budget process, as approved by the SBWMA Board.

#### Next steps

Table 1 summarizes the next steps for City Council to consider and take action to implement SB 1383 by the January 1, 2022 implementation date. By the last business meeting in December, City staff will provide the items below for City Council action. The attached ordinance language and MOUs are templates provided by partner agencies; therefore, the final versions may change.

- An ordinance to enforce the SB 1383 implementation (Attachment C), which would be modified to address the City's unique circumstances;
- A resolution to approve an MOU to implement SB 1383 (Attachment D);
- A resolution to approve an MOU to implement the Edible Food Recovery programs (Attachment E); and
- An amendment to the Recology franchise agreement (currently being developed.)

Table 1: SB 1383 requirements summary		
Requirement	Direction sought	Next City Council action
Adopt an ordinance to comply with the SB 1383 requirements by the January 1, 2022 implementation date.	Direct City staff to prepare ordinance revisions and new ordinances to comply with SB 1383 effective January 1, 2022.	Approve first reading November 9 and waive the second reading December 7.
Provide organic material collection services to all residents (single family homes and multifamily buildings) and businesses and inspect waste containers for contamination.	Prepare amendments to the Recology franchise agreement to ensure subscription and collection of organic materials.	Adopt amendments to the Recology franchise agreement on or before December 7.
Implement Edible Food Recovery programs to recover the maximum amount of edible food that would otherwise end up in the landfill.	Direct City staff and City Attorney's Office to review the County of San Mateo Office of Sustainability's MOU to delegate responsibilities to develop and enforce the food recovery program.	Approve the County's MOU on or before December 7.
Meet an annual procurement target quantity of recovered organic waste product and purchase 30 percent postconsumer recycled content paper products.	Direct City staff to amend the purchasing ordinance and update the City's environmental purchasing policy.	Approve first reading November 9 and waive the second reading December 7.
Provide education and outreach information, create reports to CalRecycle, monitor procurement requirements and maintain records of compliance.	Direct City staff and City Attorney's Office to review SBWMA's MOU and amendments to the Recology franchise agreement to authorize these implementation responsibilities to the partnering agencies.	Approve SBWMA's MOU and adopt an amendment to the Recology franchise agreement on or before December 7.

**Non-compliance**

Cities are responsible for adopting, implementing, monitoring, and enforcing the requirements outlined in SB1383. Failure to comply with the mandate may result in action by CalRecycle including:

- Administrative penalties of \$7,500 to \$10,000 per day for major violations of SB1383 regulations;
- More frequent inspections; and
- Imposition of a compliance plan by CalRecycle.

**Impact on City Resources**

Implementation costs of SB 1383 are paid by ratepayers and not general taxes. If SB 1383 is a matter requiring public outreach by City staff, either before or after implementation, a significant amount of City staff time may be required impacting the city manager's office capacity for other projects.

**Environmental Review**

This is an informational item only and is exempt from environmental review pursuant to the California Environmental Quality Act (CEQA) Guidelines sections 15378(b)(2) and 15378(b)(5) as ongoing administrative or organizational activities that will not result in direct or indirect physical changes in the environment.

### **Public Notice**

Public notification was achieved by posting the agenda, with the agenda items being listed, at least 72 hours prior to the meeting.

### **Attachments**

- A. SB 1383 compliance checklist
- B. Hyperlink – SBWMA SB 1383 compliance plan: [rethinkwaste.org/wp-content/uploads/2020/11/8\\_B\\_Attachment-A\\_WEBONLY-SBWMA-SB-1383-Plan\\_Board-111920\\_v3\\_HFH-without-Notes.pdf](https://rethinkwaste.org/wp-content/uploads/2020/11/8_B_Attachment-A_WEBONLY-SBWMA-SB-1383-Plan_Board-111920_v3_HFH-without-Notes.pdf)
- C. Draft model ordinance
- D. SBWMA implementation of SB 1383 MOU template
- E. County of San Mateo Edible Food Recovery Programs MOU template

Report prepared by:

Joanna Chen, Management Analyst I

Reviewed by:

Nick Pegueros, Assistant City Manager

# SB 1383 Summary Checklist

ATTACHMENT A

This SB 1383 Jurisdictional Checklist was prepared by HF&H Consultants, LLC based on CalRecycle's

SB 1383 Short-Lived Climate Pollutant regulations ("SB 1383") approved on November 3, 2020. HF&H provides this as a guidance document to highlight key requirements for jurisdiction compliance; however, it does not reflect all requirements. In this checklist, "jurisdiction" means city or county. Requirements that pertain only to counties are labeled accordingly. Several items in the checklist may be assigned to a jurisdiction's designee, but it is ultimately the responsibility of a jurisdiction to comply with SB 1383 pursuant to 14 CCR Section 18981.2.c. Unless otherwise stated, jurisdiction compliance with SB 1383 shall occur by January 1, 2022. SB 1383 also includes requirements for generators, haulers, food recovery services, food recovery organizations, and facility operators; however, these are not summarized in this checklist.

## Ordinances & Policies

- Adopt enforceable ordinance(s) or similar mechanism(s) requiring compliance with various SB 1383 requirements, including but not limited to: 14 CCR 18984.9.a-e, 18984.9-11, 18988.1-3, 18989.1-3, 18991.5, and 18993.1.a (14 CCR 18981.2.a) SBWMA will assist with model
- Require organic haulers to identify their organics facilities as a condition of their contract or other authorization (14 CCR 18988.1)

## Collection & Processing

- Provide organic waste collection services (including paper and cardboard collection) to all organic waste generators, except self-haulers, using compliance options listed below (14 CCR 18984)

RSMC

- Three-container collection system (14 CCR 18984.1)

- ◇ Green container for organics; delivery to organics recovery facility
- ◇ Blue container for paper, wood, dry lumber, and nonorganic recyclables; delivery to facility for recovery
- ◇ Gray container for nonorganic waste for disposal; may include organics if taken to high diversion organics processing facility

N/A

- Two-container collection systems – select one option below (14 CCR 18984.2)

- ◇ Green and gray containers: Green for organics; delivery to organics facility; gray for other materials, including organic waste not designated for the green container; delivery to high diversion organic waste processing facility
- ◇ Blue and gray containers: Blue for paper products, printing and writing paper, wood, and lumber, and textiles (optional), and nonorganic waste; gray for all other materials, including organic waste not designated for the blue container; delivery to high diversion organics processing facility

- Unsegregated single-container collection system (14 CCR 18984.3)

- ◇ Gray container for all materials; delivery to high diversion organics processing facility

- Conduct route reviews of randomly selected containers for contaminants with all routes inspected annually, or conduct waste evaluations twice a year for blue, green, and gray containers (quarterly for gray containers in performance-based approach) (14 CCR 18984.5)
- Notify generators of recycling requirements if contamination is found (14 CCR 18984.5.b, 18984.5.c)

RSMC

- Provide collection containers to generators that comply with color requirements when replacing containers after January 1, 2022 or by January 1, 2036, whichever comes first (Note: Use of containers purchased prior to January 1, 2022 is allowed) (14 CCR 18984.7)

RSMC

- Label all new containers or lids with SB 1383-compliant labels commencing January 1, 2022 (14 CCR 18984.8)

- Allow limited generator waivers for de minimis volumes and physical space constraints; maintain related records (14 CCR 18984.11)
- Determine if jurisdiction meets CalRecycle criteria for low-population, high elevation, or rural waivers; in which case, jurisdiction does not need to perform the above tasks in those geographic regions (14 CCR 18984.12)

## Edible Food Recovery

- Implement food recovery program that educates commercial edible food generators and increases access to food recovery programs (14 CCR 18991.1)
- Identify Tier One and Tier Two commercial edible food generators (14 CCR 18991.1) SBWMA and San Mateo County (SMC)
- Increase edible food recovery capacity if current capacity is insufficient (14 CCR 18991.1)
- Prior to February 1, 2022, annually thereafter, maintain list of food recovery organizations/services (14 CCR 18985.2.a)
- Prior to February 1, 2022, annually thereafter, provide Tier One/Tier Two commercial edible food generators with information on their requirements, food recovery programs, and food recovery organizations/services (14 CCR 18985.2.b)

www.hfh-consultants.com



**Northern California Office**  
201 N. Civic Drive, Suite 230  
Walnut Creek, CA 94596  
(707) 246-4803  
info@hfh-consultants.com

**Southern California Office**  
19200 Von Karman Ave, Suite 360  
Irvine, CA 92612  
(949) 504-5150  
info@hfh-consultants.com

# Procurement Requirements

- Procure a quantity of recovered organic waste, such as compost, mulch, renewable natural gas, or electricity from biomass, that meets or exceeds the annual organic waste product procurement target determined by CalRecycle and where products meet standards specified in SB 1383; procurement may be satisfied by direct service provider(s) to the jurisdiction (Note: Rural jurisdictions do not need to comply until after December 1, 2026 **(14 CCR 18993.1)** SBWMA will assist with calculations
- Purchase paper products and printing and writing paper with at least 30% post-consumer, recycled-content fibers, that are recyclable; require businesses from whom it purchases these products to certify in compliance in writing **(14 CCR 18993.3)**

## Enforcement & Penalties

- Implement desk-top compliance monitoring program for multi-family and commercial organic waste generators with two cubic yards or more of materials per week and inspection program for Tier One/Tier Two edible food generators, and food recovery organizations and services by January 1, 2022 **(14 CCR 18985.1.a)**
- Provide educational materials to regulated entities not in compliance in 2022 and 2023 **(14 CCR 18995.1.a)**
- Investigate and maintain records of all complaints received alleging non-compliance with SB 1383 **(14 CCR 18995.3)**
- Take enforcement actions, including issuing notices of violations and assessing penalties in amounts consistent with those specified in SB 1383 by January 1, 2024 **(14 CCR 18995.1.a.5, 18997.2)**
- Pay penalties if assessed by CalRecycle **(14 CCR 18997.3)**

## Education & Outreach

- SBWMA/PSMC** Prior to February 1, 2022 and annually thereafter, provide generators using two or three-container systems with information on properly separating materials, organic waste prevention, on-site recycling, methane reduction benefits, how to recycle organic waste, approved haulers, self-haul requirements, and edible food donation **(14 CCR 18985.1.a)**
- N/A**  Prior to February 1, 2022 and annually thereafter, provide generators using single-container system information on organic waste prevention, on-site recycling, methane reduction benefits, how to recycle organic waste, a list of approved haulers, self-haul requirements, edible food recovery donation information, and information that waste is processed at a high diversion organic waste processing facility **(14 CCR 18985.1.b)**
- SBWMA/PSMC**  Communications in non-English languages spoken by a substantial number of the public that are provided organic waste collection services, consistent with requirements of Government Code Section 7295 **(14 CCR 18985.1.e)**
- SBWMA/SMC**  Annually, commencing in 2022, provide Tier One and Tier Two commercial edible food generators with information on jurisdiction's edible food recovery program, generator requirements, and food recovery organizations **(14 CCR 18985.2)**

## Record Keeping & Reporting

- SBWMA** By April 1, 2022, file initial compliance report containing ordinance(s) or other enforceable mechanism(s) adopted and reporting items listed in the annual reporting section **(14 CCR 18994.1)**
- SBWMA** By October 1, 2022, and August 1 annually thereafter, submit annual SB 1383 compliance report **(14 CCR 18994.2)**
  - Maintain all implementation records in a central location (physical or electronic) that can be made available to or accessed by CalRecycle within ten business days **(14 CCR 18995.2)**
- SBWMA** Report (*by counties only*) on capacity planning activities conducted in accordance with 14 CCR 18992.1, 18992.2, 18992.3 beginning August 1, 2022, then August 1, 2024, 2029, and 2034 **(14 CCR 18992.3, 18994.2.i)**

## Capacity Planning

- Counties*, in coordination with jurisdictions and regional agencies, are responsible for the following activities
  - Conduct organics waste recycling and edible food recovery capacity planning described below **(14 CCR 18992.1, 18992.2, 18992.3)**
- SBWMA** Estimate amount of organic waste disposed, identify amount of verifiable organic waste recycling capacity available to the jurisdiction, and estimate amount of new or expanded capacity required **(14 CCR 18992.1)**
  - Estimate amount of edible food that will be disposed by Tier One/Tier Two commercial edible food generators; identify food recovery capacity available; identify new or expanded capacity; and calculate minimum capacity needed for edible food recovery from Tier One/Tier Two commercial edible food generators **(14 CCR 18992.2.a)**
- If County *determines* existing, new, or planned organic waste recycling or edible food recovery capacity is insufficient for one or more jurisdiction's needs, notify jurisdiction(s); jurisdictions shall submit an implementation schedule (including timelines and milestones) demonstrating how capacity will be secured by the end of the reporting period **(14 CCR 18992.1, 14 CCR 18992.2.c)**

SBWMA/SMC

HF&H provides this as a guidance document to highlight key requirements for jurisdiction compliance; additional requirements are applicable. Jurisdictions are advised to conduct an independent review of SB 1383 regulations to develop a list of requirements unique to their jurisdiction, or to contact HF&H Consultants, LLC for an update.

Revised December 2020.





**A Public Agency**

# Model Mandatory Organic Waste Disposal Reduction Ordinance

July 15, 2021

Developed with  
Debra Kaufman Consulting

DKC

## **DISCLAIMER**

This ordinance is not intended to cover each and every situation, nor can it anticipate specific needs. In developing this Model Ordinance, Debra Kaufman Consulting has attempted to ensure that the language herein aligns with the SB 1383 regulations; however, in the event of any conflict, the language in the regulations shall prevail over language in the Model Ordinance and determination of regulatory intent and interpretation should be appropriately guided by the regulatory language. SBWMA cannot guarantee that use of this Model Ordinance will ensure compliance with the regulatory requirements it is intended to address, however, it is based on the Model tool provided by CalRecycle.

The consultant modified the model tool provided by CalRecycle to fit the specific nature of the collection programs provided in the SBWMA service area and the anticipated SB 1383 compliance program. This model ordinance assumes the use of a standard SB 1383 compliance approach with a 3 container collection system. It allows for flexibility for the potential of future use of a two container collection system for O2E customers.

This Model Ordinance does not constitute legal advice. Member agencies are encouraged to seek legal counsel appropriate to their particular circumstances regarding compliance with regulatory requirements. This ordinance assumes that the member agencies will use a standard compliance approach, as defined in SB 1383 and a three container collection system.

CalRecycle regulations require that by January 1, 2022, a jurisdiction shall adopt an enforceable ordinance(s), or similarly enforceable mechanism to mandate that organic waste generators, haulers, and other entities that are subject to the jurisdiction's authority, comply with the requirements in SB 1383 regulations.

# MODEL ORDINANCE TABLE OF CONTENTS

SECTION 1. PURPOSE AND FINDINGS .....	1
SECTION 2. TITLE OF ORDINANCE.....	2
SECTION 3. DEFINITIONS.....	2
SECTION 4. REQUIREMENTS FOR SINGLE-FAMILY GENERATORS.....	15
SECTION 5. REQUIREMENTS FOR COMMERCIAL BUSINESSES .....	16
SECTION 6. WAIVERS FOR GENERATORS.....	19
SECTION 7. REQUIREMENTS FOR COMMERCIAL EDIBLE FOOD GENERATORS .....	21
SECTION 8. REQUIREMENTS FOR FOOD RECOVERY ORGANIZATIONS AND SERVICES .....	23
SECTION 9. REQUIREMENTS FOR HAULERS AND FACILITY OPERATORS .....	29
SECTION 10. SELF-HAULER REQUIREMENTS .....	31
SECTION 11. COMPLIANCE WITH CALGREEN RECYCLING REQUIREMENTS ....	32
SECTION 12. MODEL WATER EFFICIENT LANDSCAPING ORDINANCE REQUIREMENTS .....	34
SECTION 13. PROCUREMENT REQUIREMENTS FOR JURISDICTION DEPARTMENTS, DIRECT SERVICE PROVIDERS, AND VENDORS.....	36
SECTION 14. INSPECTIONS AND INVESTIGATIONS BY JURISDICTION.....	39
SECTION 15. ENFORCEMENT.....	40
SECTION 16. EFFECTIVE DATE.....	45



# GUIDANCE ON THE MODEL MANDATORY ORGANIC WASTE DISPOSAL REDUCTION ORDINANCE

For the purposes of this document, “SB 1383 regulations” or “SB 1383 regulatory” requirements refer to the Short-Lived Climate Pollutants (SLCP): Organic Waste Reductions regulations developed by CalRecycle and adopted in 2020 that created Chapter 12 of Title 14, Division 7 of the California Code of Regulations (CCR), and amended portions of regulations of Title 14 CCR and Title 27 CCR. The SB 1383 regulations set forth a variety of programmatic and policy-related requirements for jurisdictions, generators, and other entities to support the Statewide goals of SB 1383.

## INTRODUCTION

### IMPORTANT CONSIDERATIONS

- **Member Agencies will be referred to as Jurisdictions throughout this document.**
- **New Ordinance or Amendment of Existing Ordinance.** If jurisdictions are amending an existing ordinance, example provisions from the Model can be integrated into an existing ordinance. Jurisdictions should be mindful of the fact that this Model is intended to focus on SB 1383 regulatory requirements. A jurisdiction may choose to integrate additional provisions into its ordinance to: (i) provide more clarification on how regulated entities are expected to comply; (ii) expand beyond the SB 1383 regulatory requirements; and/or (iii) include other solid waste handling and diversion requirements.
- **Standard based or performance based compliance.** For the purpose of the Model, “Standard Compliance Approach” means the method for complying with the SB 1383 regulations through implementation of organic waste collection programs and policies in accordance with 14 CCR Division 7, Chapter 12, Article 3 and associated requirements. Generally, all provisions in the SB 1383 regulations, other than 14 CCR, Division 7, Chapter 12, Article 17, apply to the Standard-Compliance Approach, unless the Performance-Based Compliance Approach is specifically referenced.

This model assumes a standard based SB 1383 compliance approach, which offers jurisdictions more flexibility in their collection system as well as more consistency with their program parameters in the event that contamination is higher than anticipated. It does, however, come with some additional regulatory requirements. Many, but not all of those requirements are included in this model ordinance. In contrast, a performance based compliance approach requires providing 3 container service to 90 percent of a jurisdiction’s residential and commercial generators and demonstrating specified high

levels of recovery at specified facilities. If performance based recovery standards are not met, jurisdictions would be required to meet the more stringent standard based compliance requirements. If circumstances change in the future, jurisdictions can change their ordinance more easily from a standard based compliance approach to a performance based compliance approach, as the latter would have fewer requirements for the jurisdiction to enforce, but this would likely require some ordinance revision.

- **SB 1383 Regulatory Requirements.** Each jurisdiction is responsible for understanding and achieving compliance with SB 1383 regulations. Use of the Model Ordinance does not exempt a jurisdiction from complying with all SB 1383 regulatory requirements. The Model Ordinance includes example language that supports compliance with some, but not all SB 1383 regulatory requirements. The Model Ordinance is designed to enable the jurisdiction to require and enforce provisions that SB 1383 regulations require jurisdictions to require and enforce. It does not include the requirements on the jurisdiction itself, which CalRecycle will be enforcing on the jurisdiction, including recordkeeping, contamination monitoring, recovered organic waste product procurement target attainment, and outreach and education. It is advised that jurisdictions thoroughly review the SB 1383 regulations and take necessary actions to ensure full compliance.
- **Involve Legal Counsel.** Each jurisdiction is responsible for involving its legal counsel to perform legal review and approval processes typically required by the jurisdiction for approval of such ordinances.
- **Engage with Affected Entities** When adopting a new or amended ordinance, it is advised that the review and adoption process involve engagement with the regulated entities, which will help with the implementation process as they will be more aware of the upcoming requirements. For example, engagement with organic waste generators, haulers, food recovery organizations, and food recovery services may help jurisdictions to obtain useful input from these stakeholders.
- **Example Language Only.** The provisions in the Model Ordinance are examples of how some SB 1383 regulatory requirements may be integrated and worded in an ordinance. Jurisdictions are not required to use this exact language. The language does, however, reflect the requirements that jurisdictions are required to place on others. All language should be considered in the context of the specific requirements contained in the SB 1383 regulations and the jurisdictions' unique conditions.
- **Review Highlighted Text.** Highlighted text has been provided throughout the Model Ordinance to indicate guidance, jurisdiction-specific language, and County of San Mateo Office of Sustainability required language.

## Guide to Highlighted Text

Text	Explanation
Guidance	Guidance notes are integrated into the Model to explain how specific sections and provisions of the Model can be customized for a jurisdiction's needs. These are to be deleted in the final ordinance.
Jurisdiction-Specific	There are areas where specific information needs to be provided by the jurisdiction
County of San Mateo Office of Sustainability required Edible Food Recovery Program Language.	This language has been provided by the County of San Mateo Office of Sustainability and is required for participation in their Edible Food Recovery Program

## CUSTOMIZATION CONSIDERATIONS

The Model Ordinance is customizable to provide flexibility for each jurisdiction's needs.

The following notes some of the sections that should be closely reviewed to ensure that the final document reflects the individual jurisdiction's circumstances. More specific guidance is included in the Model

### 3. WAIVERS AND EXEMPTIONS

SB 1383 regulations allow jurisdictions to grant waivers to some generators for de minimis volumes, physical space limitations, and less-than-weekly collection frequency, although these waivers are not required. The Model Ordinance includes sample language should a jurisdiction decide to include such waivers.

### 4. DELEGATION OF RESPONSIBILITIES & ENFORCEMENT

Jurisdictions are advised to consider which enforcement requirements of the SB 1383 regulations will remain the responsibility of the jurisdiction and which will be delegated to other entities under a written agreement. Some jurisdictions may choose to conduct inspections and enforcement themselves and others may enter an agreement another government entity to conduct such inspections and enforcement on their behalf. Jurisdictions should consider whether it is sharing responsibility for enforcement with any other public

entities when considering what language to include. Example language to reflect a shared enforcement methodology is presented in the Model Ordinance. It is important to note that regardless of how a jurisdiction chooses to handle enforcement, the jurisdiction itself remains responsible for enforcement, and could be subject to penalties based on non-enforcement, according to SB 1383 regulations. It is also important to understand that SB 1383 regulations prohibit a jurisdiction from delegating its authority to impose civil penalties, or to maintain an action to impose civil penalties, to a private entity. As written, the language in the enforcement section of the model ordinance is consistent with the enforcement process and timeline outlined in SB 1383 regulations; and California Government Code Section 53069.4. Jurisdictions should ensure that the enforcement language is also consistent with their own administrative procedures on enforcement actions.

## **6. ALIGNMENT OF DEFINED TERMS**

The Model Ordinance includes many terms which were obtained from SB 1383 regulatory definitions and some from example ordinances and franchise agreements. The definitions provided herein are consistent with SB 1383 regulations. The definitions have been modified to be consistent with current Recology collection program parameters including materials collected and container colors. Jurisdictions are advised to review the definitions to ensure consistency amongst definitions used in existing franchises, processing agreements, and municipal code, while still meeting SB 1383 regulatory requirements. Jurisdictions may need to amend the definitions in their municipal/county code to align with updated definitions in their ordinance and franchise agreement. Jurisdictions should attempt to coordinate definitions used in the ordinance, their franchise agreement, and their municipal/county code sections related to solid waste collection and recycling.

While jurisdictions may modify or create their own definitions or delete definitions, jurisdictions must ensure that all SB 1383 regulatory requirements are met. For example, material streams can be defined, renamed, or further subdivided, or the jurisdiction may wish to refer to the containers by material stream type rather than color; however, the ordinance must include requirements to assure that all organic waste specified in SB 1383 regulations for collection is collected and processed or managed in a compliant manner.

Additionally, the Model refers to containers by their colors (black, green, blue) as is done in the SB 1383 regulations.

The following figure identifies the defined terms used in the Model Ordinance to describe the various material streams associated with each color container. This is provided for convenience to orient the user to the terminology, which, in some cases, is likely to be different than their current terminology.

## Defined Terms Used in Model Ordinance

Container Color	Terminology of Material Streams
Blue Containers	<ul style="list-style-type: none"> <li>• Source separated recyclable materials</li> <li>• Non-organic recyclables - glass, metal, plastic, etc.</li> <li>• Source separated blue container organic waste – organic recyclables such as fibers and cardboard</li> </ul>
Green containers	<ul style="list-style-type: none"> <li>• Source separated Green Container organic waste including food, food soiled paper, plant debris.</li> </ul>
Black containers	<ul style="list-style-type: none"> <li>• Black container waste (three container system that does not allow organic waste, such as food waste, in the black container)</li> <li>• Mixed waste organic collection stream or mixed waste (two- and one-container systems and three- and three-plus-container systems that allow organic waste, such as food waste, in the black container)</li> </ul>

*Note: Organic waste is a defined term that serves as an umbrella for all organics including source separated blue container organic waste, source separated green container organic waste, textiles, carpet, etc. Organic wastes are collected in a combination of containers depending on the collection system and therefore not separately identified in the table above.*

## ADDITIONAL TIPS FOR USING THE MODEL

1. **Modify Language.** Adjust the Model language to fit the jurisdiction’s specific needs.
2. **Change Jurisdiction.** The term “jurisdiction” is used throughout this Model Ordinance; however, the entity responsible for adopting this Ordinance will need to change “jurisdiction” throughout the document to the appropriate term, which may be City, Town, County or Special District that provides solid waste handling services.
3. **Delete Guidance Notes**
4. **Blend Existing Ordinance Provisions with Model Provisions.** When using the Model Ordinance, users may want to select provisions from both the Model Ordinance and any existing recycling or solid waste related ordinance(s), and codes to create an ordinance that best suits its needs.

## ADDITIONAL CALRECYCLE RESOURCES

1. SB 1383 General Information: <https://www.calrecycle.ca.gov/organics/slcp>

2. SB 1383 Regulations: <https://www2.calrecycle.ca.gov/Docs/Web/118371> (for an accessible version, please use this link: <https://www2.calrecycle.ca.gov/Docs/Web/118368>)

3. SB 1383 Model Implementation Tools: <https://www.calrecycle.ca.gov/organics/slcp/education>

This webpage includes the following Model Tools:

- Model Franchise Agreement
- Model Mandatory Organic Waste Disposal Reduction Ordinance
- Model Recovered Organic Waste Product Procurement Policy
- Model Food Recovery Agreement

4. Other Recovered Organic Waste Product Procurement Resources

- Calculator for Annual Recovered Organic Waste Product Procurement: <https://www2.calrecycle.ca.gov/Docs/Web/118521>

5. SB 1383 Case Studies: <https://www.calrecycle.ca.gov/organics/slcp/education>

Eight case studies are available including two each on franchise agreements, mandatory organic waste disposal reduction ordinances, recovered organic waste product procurement, and food recovery programs and policies.

6. Other Relevant SB 1383 CalRecycle Reports

- SB 1383 Local Services Rates Analysis: <https://www2.calrecycle.ca.gov/Publications/Details/1698>
- SB 1383 Infrastructure and Market Analysis: <https://www2.calrecycle.ca.gov/Publications/Details/1652>

7. Relevant Regulations Referenced in the Model Policy:

- Title 14 of California Code of Regulations, Division 7, Department of Resources Recycling and Recovery: [https://govt.westlaw.com/calregs/Browse/Home/California/CaliforniaCodeofRegulations?guid=IFF17BBCC72F5412C8FEEF78290C1526E&originationContext=documenttoc&transitionType=Default&contextData=\(sc.Default\)](https://govt.westlaw.com/calregs/Browse/Home/California/CaliforniaCodeofRegulations?guid=IFF17BBCC72F5412C8FEEF78290C1526E&originationContext=documenttoc&transitionType=Default&contextData=(sc.Default))
- Title 27 of California Code of Regulations, Division 2, Environmental Protection, Solid Waste (27 CCR Division 2): <https://www.calrecycle.ca.gov/laws/regulations/title27>
- Model Water Efficient Landscape Ordinance, Title 23, Division 2, Chapter 2.7 of California Code of Regulations:

<https://govt.westlaw.com/calregs/Browse/Home/California/CaliforniaCodeofRegulations?guid=I55B69DB0D45A11DEA95CA4428EC25FA0&transitionType=Default&contextData=%28sc.Default%29>

- Public Contract Code (including recycled-content paper requirements):  
[https://leginfo.legislature.ca.gov/faces/codes\\_displayexpandedbranch.xhtml?tocCode=PCC&division=2.&title=&part=2.&chapter=&article=&goUp=Y](https://leginfo.legislature.ca.gov/faces/codes_displayexpandedbranch.xhtml?tocCode=PCC&division=2.&title=&part=2.&chapter=&article=&goUp=Y)
- Public Resources Code:  
[http://leginfo.legislature.ca.gov/faces/codes\\_displayexpandedbranch.xhtml?lawCode=PRC&division=30.&title=&part=1.&chapter=2.&article=&goUp=Y](http://leginfo.legislature.ca.gov/faces/codes_displayexpandedbranch.xhtml?lawCode=PRC&division=30.&title=&part=1.&chapter=2.&article=&goUp=Y)
- Code of Federal Regulations, Title 16 (including relevant definitions):  
<https://www.govinfo.gov/app/details/CFR-2013-title16-vol1/CFR-2013-title16-vol1-sec260-12/context>

*This page intentionally left blank*



1 **SBWMA MODEL MANDATORY ORGANIC**  
2 **WASTE DISPOSAL REDUCTION ORDINANCE**

3 **SECTION 1. PURPOSE AND FINDINGS**

4 The Jurisdiction finds and declares:

5 (a) State recycling law, Assembly Bill 939 of 1989, the California Integrated Waste  
6 Management Act of 1989 (California Public Resources Code Section 40000, et  
7 seq., as amended, supplemented, superseded, and replaced from time to time),  
8 requires cities and counties to reduce, reuse, and recycle (including composting)  
9 Solid Waste generated in their Jurisdictions to the maximum extent feasible before  
10 any incineration or landfill disposal of waste, to conserve water, energy, and other  
11 natural resources, and to protect the environment.

12 (b) State recycling law, Assembly Bill 341 of 2011 (approved by the Governor of the  
13 State of California on October 5, 2011, which amended Sections 41730, 41731,  
14 41734, 41735, 41736, 41800, 42926, 44004, and 50001 of, and added Sections  
15 40004, 41734.5, and 41780.01 and Chapter 12.8 (commencing with Section  
16 42649) to Part 3 of Division 30 of, and added and repealed Section 41780.02 of,  
17 the Public Resources Code, as amended, supplemented, superseded and  
18 replaced from time to time), places requirements on businesses and Multi-Family  
19 property owners that generate a specified threshold amount of Solid Waste to  
20 arrange for recycling services and requires Jurisdictions to implement a Mandatory  
21 Commercial Recycling program.

22 (c) State organics recycling law, Assembly Bill 1826 of 2014 (approved by the  
23 Governor of the State of California on September 28, 2014, which added Chapter  
24 12.9 (commencing with Section 42649.8) to Part 3 of Division 30 of the Public  
25 Resources Code, relating to Solid Waste, as amended, supplemented,  
26 superseded, and replaced from time to time), requires businesses and Multi-Family  
27 property owners that generate a specified threshold amount of Solid Waste,  
28 Recycling, and Organic Waste per week to arrange for recycling services for that  
29 waste, requires Jurisdictions to implement a recycling program to divert Organic  
30 Waste from businesses subject to the law, and requires Jurisdictions to implement  
31 a Mandatory Commercial Organics Recycling program.

32 (d) SB 1383, the Short-lived Climate Pollutant Reduction Act of 2016, requires  
33 CalRecycle to develop regulations to reduce organics in landfills as a source of  
34 methane. The regulations place requirements on multiple entities including  
35 Jurisdictions, residential households, Commercial Businesses and business  
36 owners, Commercial Edible Food Generators, haulers, Self-Haulers, Food  
37 Recovery Organizations, and Food Recovery Services to support achievement of  
38 Statewide Organic Waste disposal reduction targets.

39 (e) SB 1383, the Short-lived Climate Pollutant Reduction Act of 2016, requires  
40 Jurisdictions to adopt and enforce an ordinance or enforceable mechanism to  
41 implement relevant provisions of SB 1383 Regulations. This ordinance will also  
42 help reduce food insecurity by requiring Commercial Edible Food Generators to  
43 arrange to have the maximum amount of their Edible Food, that would otherwise  
44 be disposed, be recovered for human consumption.

45 (f) Requirements in this ordinance are consistent with other adopted goals and  
46 policies of the Jurisdiction including: \_\_\_\_\_ (Jurisdiction to insert  
47 description).

48 Guidance: At Jurisdiction’s option, Jurisdictions may want to include this  
49 subsection (f) to add Jurisdiction-specific diversion goals or policies here such as  
50 a 75% diversion or zero waste goal, C&D recovery ordinance, greenhouse gas  
51 reduction goals, local climate action plan, WELO, procurement policy, etc.

52 (g) Even if the jurisdiction delegates responsibility for enforcement to another public  
53 entity, the jurisdiction itself will remain ultimately responsible for compliance of this  
54 ordinance as required in 14 CCR Section 18981.2 (c).

## 55 SECTION 2. TITLE OF ORDINANCE

56 This chapter shall be entitled “Mandatory Organic Waste Disposal Reduction Ordinance”.

## 57 SECTION 3. DEFINITIONS

58 Guidance: Most of the following definitions are excerpted from the SB 1383 Regulations  
59 (14 CCR Section 18982). There are additional definitions in the SB 1383 Regulations that  
60 are not included here. Jurisdiction may want to review that list of definitions in 14 CCR  
61 Section 18982 to determine whether it wants to add any additional definitions to its  
62 ordinance. Jurisdiction may also choose to delete definitions not appropriate for its  
63 conditions and/or to include additional definitions that are appropriate for its ordinance.

64 (a) “Blue Container” has the same meaning as in 14 CCR Section 18982.2(a)(5) and  
65 shall be used for the purpose of storage and collection of Source Separated  
66 Recyclable Materials or Source Separated Blue Container Organic Waste.

67 (b) “Black Container” has the same meaning as in 14 CCR Section 18982.2(a)(28)  
68 and shall be used for the purpose of storage and collection of Black Container  
69 Waste.

70 (c) “Black Container Waste” means Solid Waste that is collected in a Black Container  
71 that is part of a three-container Organic Waste collection service that prohibits the  
72 placement of Organic Waste or Source Separated Recyclables in the Black  
73 Container as specified in 14 CCR Sections 18984.1(a) and (b), or as otherwise  
74 defined in 14 CCR Section 17402(a)(6.5).

75

76 (d) “CalRecycle” means California's Department of Resources Recycling and  
77 Recovery, which is the Department designated with responsibility for developing,  
78 implementing, and enforcing SB 1383 Regulations on Jurisdictions (and others).

79 (e) “California Code of Regulations” or “CCR” means the State of California Code of  
80 Regulations. CCR references in this ordinance are preceded with a number that  
81 refers to the relevant Title of the CCR (e.g., “14 CCR” refers to Title 14 of CCR).

82 (f) “Commercial Business” or “Commercial” means a firm, partnership, proprietorship,  
83 joint-stock company, corporation, or association, whether for-profit or nonprofit,  
84 strip mall, industrial facility, or a multifamily residential dwelling, or as otherwise  
85 defined in 14 CCR Section 18982(a)(6). A Multi-Family Residential Dwelling that  
86 consists of fewer than five (5) units is not a Commercial Business for purposes of  
87 implementing this ordinance.

88 (g) “Commercial Edible Food Generator” includes a Tier One or a Tier Two  
89 Commercial Edible Food Generator as defined in this ordinance. For the purposes  
90 of this definition, Food Recovery Organizations and Food Recovery Services are  
91 not Commercial Edible Food Generators pursuant to 14 CCR Section 18982(a)(7).

92 (h) “Compliance Review” means a review of records by a Jurisdiction or its designated  
93 entity to determine compliance with this ordinance.

94 (i) “Community Composting” means any activity that composts green material, agricultural  
95 material, food material, and vegetative food material, alone or in combination, and  
96 the total amount of feedstock and Compost on-site at any one time does not  
97 exceed 100 cubic yards and 750 square feet, as specified in 14 CCR Section  
98 17855(a)(4); or, as otherwise defined by 14 CCR Section 18982(a)(8).

99 (j) “Compost” has the same meaning as in 14 CCR Section 17896.2(a)(4), which  
100 stated, as of the effective date of this ordinance, that “Compost” means the product  
101 resulting from the controlled biological decomposition of organic Solid Wastes that  
102 are Source Separated from the municipal Solid Waste stream, or which are  
103 separated at a centralized facility.

104 Compost eligible for meeting the Jurisdiction’s Annual Recovered Organic Waste  
105 Product Procurement Target must be produced at a compostable material handling  
106 operation or facility permitted or authorized under 14 CCR Chapter 3.1 of Division  
107 7 or produced at a large volume in-vessel digestion facility that composts on-site  
108 as defined and permitted under 14 CCR Chapter 3.2 of Division 7. Compost shall  
109 meet the State’s composting operations regulatory requirements.

110 (k) “Container Contamination” or “Contaminated Container” means a container,  
111 regardless of color, that contains Prohibited Container Contaminants, or as  
112 otherwise defined in 14 CCR Section 18982(a)(55).

- 113 (l) “C&D” means construction and demolition debris.
- 114 (m) “Designated Source Separated Organic Waste Facility”, as defined in 14 CCR  
115 Section 18982(14.5), means a Solid Waste facility that accepts a Source  
116 Separated Organic Waste collection stream as defined in 14 CCR Section  
117 17402(a)(26.6) and complies with one of the following:
- 118 (1) The facility is a “transfer/processor,” as defined in 14 CCR Section  
119 18815.2(a)(62), that is in compliance with the reporting requirements of 14  
120 CCR Section 18815.5(d), and meets or exceeds an annual average Source  
121 Separated organic content Recovery rate of 50 percent between January 1,  
122 2022 and December 31, 2024 and 75 percent on and after January 1, 2025  
123 as calculated pursuant to 14 CCR Section 18815.5(f) for Organic Waste  
124 received from the Source Separated Organic Waste collection stream.
- 125 (A) If a transfer/processor has an annual average Source Separated  
126 organic content Recovery rate lower than the rate required in  
127 Paragraph 1 of this definition for two (2) consecutive reporting  
128 periods, or three (3) reporting periods within three (3) years, the  
129 facility shall not qualify as a “Designated Source Separated Organic  
130 Waste Facility”.
- 131 (2) The facility is a “composting operation” or “composting facility” as defined in  
132 14 CCR Section 18815.2(a)(13), that pursuant to the reports submitted  
133 under 14 CCR Section 18815.7 demonstrates that the percent of the  
134 material removed for landfill disposal that is Organic Waste is less than the  
135 percent specified in 14 CCR Section 17409.5.8(c)(2) or 17409.5.8(c)(3),  
136 whichever is applicable, and, if applicable, complies with the digestate  
137 handling requirements specified in 14 CCR Section 17896.5. The definition  
138 of composting operation includes in-vessel digestion as regulated in 14  
139 CCR Section 17896.
- 140 (A) If the percent of the material removed for landfill disposal that is  
141 Organic Waste is more than the percent specified in 14 CCR Section  
142 17409.5.8(c)(2) or 17409.5.8(c)(3), for two (2) consecutive reporting  
143 periods, or three (3) reporting periods within three (3) years, the  
144 facility shall not qualify as a “Designated Source Separated Organic  
145 Waste Facility.” For the purposes of this ordinance, the reporting  
146 periods shall be consistent with those defined in 14 CCR Section  
147 18815.2(a)(49).

148 Guidance: The reporting periods identified in the above Section  
149 3(l)(2)(A) are consistent with reporting that facilities must submit to  
150 CalRecycle under RDRS regulations and not reporting to be  
151 submitted under this ordinance.

152 (n) i. "Designee" means an entity that a Jurisdiction contracts with or otherwise  
153 arranges to carry out any of the Jurisdiction's responsibilities of this ordinance as  
154 authorized in 14 CCR Section 18981.2. A Designee may be a government entity,  
155 a hauler, a private entity, or a combination of those entities.

156 ii. "Designee for Edible Food Recovery" means the County of San Mateo's Office  
157 of Sustainability with which the Jurisdiction has a Memorandum of Understanding  
158 for the purposes of Edible Food Recovery including, but not limited to, inspection,  
159 investigation, and enforcement of the Edible Food Recovery provisions of this  
160 ordinance. Contact information for the Designee for Edible Food Recovery can be  
161 found on the County of San Mateo's Office of Sustainability website.

162 Guidance: Note that SB 1383 regulations prohibit a jurisdiction from delegating its  
163 authority to impose civil penalties, or to maintain an action to impose civil penalties,  
164 to a private entity.

165 (o) "Edible Food" means food intended for and fit for human consumption and  
166 collected or received from a Tier One or Tier Two Commercial Edible Food  
167 Generator. For the purposes of this ordinance "Edible Food" is not Solid Waste if  
168 it is recovered and not discarded. Nothing in this ordinance or in 14 CCR, Division  
169 7, Chapter 12 requires or authorizes the Recovery of Edible Food that does not  
170 meet the food safety requirements of the California Retail Food Code.

171 (p) "Edible Food Recovery" means actions to collect, receive, and/or re-distribute  
172 Edible Food for human consumption from Tier One and Tier Two Commercial  
173 Edible Food Generators that otherwise would be disposed.

174 (q) "Enforcement Action" means an action of the Jurisdiction or County of San Mateo's  
175 Office of Sustainability to address non-compliance with this ordinance including,  
176 but not limited to, issuing administrative citations, fines, penalties, or using other  
177 remedies.

178 (r) "Excluded Waste" means hazardous substance, hazardous waste, infectious  
179 waste, designated waste, volatile, corrosive, medical waste, infectious, regulated  
180 radioactive waste, and toxic substances. Excluded wastes also includes  
181 construction materials, dirt, rock and concrete, electronic waste and batteries,  
182 fluorescent lights, hazardous waste, liquids and grease, medicines and sharps and  
183 treated wood.

184 These include material that facility collectors and operator(s), which receive  
185 materials from the Jurisdiction and its generators, reasonably believe(s) would, as  
186 a result of or upon acceptance, transfer, processing, or disposal, be a violation of  
187 local, State, or Federal law, regulation, or ordinance, including: land use  
188 restrictions or conditions, waste that cannot be disposed of in Class III landfills or  
189 accepted at the facility by permit conditions, waste that in Jurisdictions, or its  
190 Designee's reasonable opinion would present a significant risk to human health or  
191 the environment, cause a nuisance or otherwise create or expose Jurisdiction, or

192 its Designee, to potential liability; but not including de minimis volumes or  
193 concentrations of waste of a type and amount normally found in Single-Family or  
194 Multi-Family Solid Waste after implementation of programs for the safe collection,  
195 processing, recycling, treatment, and disposal of batteries and paint in compliance  
196 with Sections 41500 and 41802 of the California Public Resources Code. Excluded  
197 Waste does not include household batteries placed in a sealed clear plastic bag  
198 placed on top of the black can, or any other universal wastes if such materials are  
199 defined as allowable materials for collection through the Jurisdiction’s collection  
200 programs and the generator or customer has properly placed the materials for  
201 collection pursuant to instructions provided by Jurisdiction or its Designee for  
202 collection services.

203 (s) “Food Distributor” means a company that distributes food to entities including, but  
204 not limited to, Supermarkets and Grocery Stores.

205 (t) “Food Facility” has the same meaning as in Section 113789 of the Health and  
206 Safety Code.

207 (u) “Food Recovery” means actions to collect, receive and or re-distribute edible food  
208 for human consumption from Tier One and Tier Two Commercial Edible Food  
209 Generators, that otherwise would be disposed.

210 (v) “Food Recovery Organization” means an entity that engages in the collection or  
211 receipt of Edible Food from Commercial Edible Food Generators and distributes  
212 that Edible Food to the public for Food Recovery either directly or through other  
213 entities or as otherwise defined in 14 CCR Section 18982(a)(25), including, but not  
214 limited to:

215 (1) A food bank as defined in Section 113783 of the Health and Safety Code;

216 (2) A nonprofit charitable organization as defined in Section 113841 of the  
217 Health and Safety code; and,

218 (3) A nonprofit charitable temporary food facility as defined in Section 113842  
219 of the Health and Safety Code.

220 A Food Recovery Organization is not a Commercial Edible Food Generator for the  
221 purposes of this ordinance and implementation of 14 CCR, Division 7, Chapter 12  
222 pursuant to 14 CCR Section 18982(a)(7).

223 If the definition in 14 CCR Section 18982(a)(25) for Food Recovery Organization  
224 differs from this definition, the definition in 14 CCR Section 18982(a)(25) shall  
225 apply to this ordinance.

226 (w) “Food Recovery Service” means a person or entity that collects and transports  
227 Edible Food from a Tier One or Tier Two Commercial Edible Food Generator to a  
228 Food Recovery Organization or other entities for Edible Food Recovery. A Food  
229 Recovery Service is not a Commercial Edible Food Generator for the purposes of

- 230 this ordinance and implementation of 14 CCR, Division 7, Chapter 12 pursuant to  
231 14 CCR Section 18982(a)(7).
- 232 (x) “Food Scraps” means all food such as, but not limited to, fruits, vegetables, meat,  
233 poultry, seafood, shellfish, bones, rice, beans, pasta, bread, cheese, and  
234 eggshells. Food Scraps excludes fats, oils, and grease when such materials are  
235 Source Separated from other Food Scraps.
- 236 (y) “Food Service Provider” means an entity primarily engaged in providing food  
237 services to institutional, governmental, commercial, or industrial locations of others  
238 based on contractual arrangements with these types of organizations.
- 239 (z) “Food-Soiled Paper” is compostable paper material that has come in contact with  
240 food or liquid, such as, but not limited to, compostable paper plates, paper coffee  
241 cups, napkins, pizza boxes, and milk cartons and should be placed in the green  
242 compost container with food scraps.
- 243 (aa) “Food Waste” means Food Scraps, Food-Soiled Paper, and bio-plastics  
244 labeled “BPI Certified Compostable”.
- 245 (bb) “Green Container” has the same meaning as in 14 CCR Section 18982.2(a)(29)  
246 and shall be used for the purpose of storage and collection of Source Separated  
247 Green Container Organic Waste.
- 248 (cc) “Greenhouse gas (GHG)” means carbon dioxide (CO<sub>2</sub>), methane (CH<sub>4</sub>), nitrous  
249 oxide (N<sub>2</sub>O), sulfur hexafluoride (SF<sub>6</sub>), hydrofluorocarbons (HFC),  
250 perfluorocarbons (PFC) and other fluorinated greenhouse gases.
- 251 (dd) “Greenhouse gas emission reduction” or “greenhouse gas reduction” means a  
252 calculated decrease in greenhouse gas emissions relative to a project baseline  
253 over a specified period of time, resulting from actions designed to achieve such a  
254 decrease.
- 255 (ee) “Grocery Store” means a store primarily engaged in the retail sale of canned food;  
256 dry goods; fresh fruits and vegetables; fresh meats, fish, and poultry; and any area  
257 that is not separately owned within the store where the food is prepared and  
258 served, including a bakery, deli, and meat and seafood departments, or as  
259 otherwise defined in 14 CCR Section 18982(a)(30).
- 260 (ff) “High Diversion Organic Waste Processing Facility” means a facility that is in  
261 compliance with the reporting requirements of 14 CCR Section 18815.5(d) and  
262 meets or exceeds an annual average Mixed Waste organic content Recovery rate  
263 of 50 percent between January 1, 2022 and December 31, 2024, and 75 percent  
264 after January 1, 2025, as calculated pursuant to 14 CCR Section 18815.5(e) for  
265 Organic Waste received from the “Mixed waste organic collection stream” as  
266 defined in 14 CCR Section 17402(a)(11.5); or, as otherwise defined in 14 CCR  
267 Section 18982(a)(33).

268 (gg) “Inspection” means a site visit where a Jurisdiction or its designee, reviews  
269 records, containers, and an entity’s collection, handling, recycling, or landfill  
270 disposal of Organic Waste or Edible Food handling to determine if the entity is  
271 complying with requirements set forth in this ordinance, or as otherwise defined in  
272 14 CCR Section 18982(a)(35).

273 “Inspection” for the purposes of Edible Food Recovery, means actions to review  
274 contracts and other records related to the recovery of edible food and may occur  
275 off-site via email and other forms of electronic communication, as well as the on-  
276 site review of an entity’s records and collection, handling and other procedures for  
277 the recovery of edible food to determine if the entity is complying with the  
278 requirements of this ordinance.

279 (hh) “Jurisdiction” is the entity responsible for ensuring solid waste, recycling and  
280 organics service is provided in accordance with SB 1383 guidelines.

281 (ii) “Jurisdiction Enforcement Official” means the city manager, county administrative  
282 official, chief operating officer, executive director, or other executive in charge or  
283 their authorized Designee(s) who is/are partially or whole responsible for enforcing  
284 the ordinance. See also “Designee for Edible Food Recovery.”

285 Guidance: Enforcement does not have to be limited to one person; however, the  
286 Jurisdiction may not delegate its authority to impose civil penalties required by the  
287 SB 1383 Regulations to a private entity pursuant to 14 CCR Section 18981.2(d).

288 (jj) “Large Event” means an event, including, but not limited to, a sporting event or a  
289 flea market, that charges an admission price, or is operated by a local agency, and  
290 serves an average of more than 2,000 individuals per day of operation of the event,  
291 at a location that includes, but is not limited to, a public, nonprofit, or privately  
292 owned park, parking lot, golf course, street system, or other open space when  
293 being used for an event. If the definition in 14 CCR Section 18982(a)(38) differs  
294 from this definition, the definition in 14 CCR Section 18982(a)(38) shall apply to  
295 this ordinance.

296 (kk) “Large Venue” means a permanent venue facility that annually seats or serves an  
297 average of more than 2,000 individuals within the grounds of the facility per day of  
298 operation of the venue facility. For purposes of this ordinance and implementation  
299 of 14 CCR, Division 7, Chapter 12, a venue facility includes, but is not limited to, a  
300 public, nonprofit, or privately owned or operated stadium, amphitheater, arena,  
301 hall, amusement park, conference or civic center, zoo, aquarium, airport,  
302 racetrack, horse track, performing arts center, fairground, museum, theater, or  
303 other public attraction facility. For purposes of this ordinance and implementation  
304 of 14 CCR, Division 7, Chapter 12, a site under common ownership or control that  
305 includes more than one Large Venue that is contiguous with other Large Venues  
306 in the site, is a single Large Venue. If the definition in 14 CCR Section 18982(a)(39)  
307 differs from this definition, the definition in 14 CCR Section 18982(a)(39) shall  
308 apply to this ordinance.



309 (ll) "Local Education Agency" means a school district, charter school, or county office  
310 of education that is not subject to the control of city or county regulations related  
311 to Solid Waste, or as otherwise defined in 14 CCR Section 18982(a)(40).

312 (mm) "Mixed Waste Organic Collection Stream" or "Mixed Waste" means Organic Waste  
313 collected in a black container that is required by 14 CCR Sections 18984.1,  
314 18984.2 or 18984.3 to be taken to a High Diversion Organic Waste Processing  
315 Facility or as otherwise defined in 14 CCR Section 17402(a)(11.5). This definition  
316 is only applicable to select commercial and MF customers provided with a two  
317 container collection system. Three container collection system customers will use  
318 the black container waste definition instead.

319 Guidance: This definition is included in the event that Jurisdictions use the O2E  
320 system in the future for selected commercial and MF customers. That collection  
321 system envisions using a two-container system that allows Organic Waste, such  
322 as Food Waste, to be collected in the Black container. In these cases, materials in  
323 the Black containers are to be processed at a High Diversion Organic Waste  
324 Processing Facility. Generators using the three container system would not be  
325 allowed to place Organic Waste in the Black container.

326 (nn) "Multi-Family Residential Dwelling" or "Multi-Family" means of, from, or pertaining  
327 to residential premises with five (5) or more dwelling units. Multi-Family premises  
328 do not include hotels, motels, or other transient occupancy facilities, which are  
329 considered Commercial Businesses. Under the SB 1383 Regulations and in this  
330 Ordinance, Multi-Family Residential Dwellings with five (5) or more units are  
331 included under the definition of a Commercial Business per 14 CCR Section  
332 18982(a)(6).

333 (oo) "MWELo" refers to the Model Water Efficient Landscape Ordinance (MWELo), 23  
334 CCR, Division 2, Chapter 2.7.

335 Guidance: If jurisdiction has its own WELO that meets the MWELo standards then  
336 it can be listed here instead of MWELo.

337 (pp) "Non-Compostable Paper" includes but is not limited to paper that is coated in a  
338 plastic material that will not breakdown in the composting process, or as otherwise  
339 defined in 14 CCR Section 18982(a)(41).

340 (qq) "Non-Local Entity" means the following entities that are not subject to the  
341 Jurisdiction's enforcement authority, or as otherwise defined in 14 CCR Section  
342 18982(a)(42):

343 Guidance: Jurisdiction should include one or more of the items below as  
344 appropriate for Jurisdiction, and delete non-applicable items.

345 (1) Special district(s) located within the boundaries of the Jurisdiction, including  
346 \_\_\_\_\_ (insert names of special districts).

- 347 (2) Federal facilities, including military installations, located within the  
 348 boundaries of the Jurisdiction, including \_\_\_\_\_ (insert names of federal  
 349 facilities).
- 350 (3) Prison(s) located within the boundaries of the Jurisdiction, including  
 351 \_\_\_\_\_ (insert names of prisons). Guidance: Private prisons are  
 352 considered Commercial Businesses and should not be listed here.
- 353 (4) Facilities operated by the State park system located within the boundaries  
 354 of the Jurisdiction, including \_\_\_\_\_ (insert names of State park  
 355 facilities).
- 356 (5) Public universities (including community colleges) located within the  
 357 boundaries of the Jurisdiction, including \_\_\_\_\_ (insert names of  
 358 universities).
- 359 (6) County fairgrounds located within the boundaries of the Jurisdiction,  
 360 including \_\_\_\_\_ (insert names of fairgrounds).
- 361 (7) State agencies located within the boundaries of the Jurisdiction, including  
 362 \_\_\_\_\_ (insert names of State agencies).
- 363 (rr) “Non-Organic Recyclables” means non-putrescible and non-hazardous recyclable  
 364 wastes including but not limited to bottles, cans, metals, plastics and glass, or as  
 365 otherwise defined in 14 CCR Section 18982(a)(43).
- 366 (ss) “Notice of Violation (NOV)” means a notice that a violation has occurred that  
 367 includes a compliance date to avoid an action to seek penalties, or as otherwise  
 368 defined in 14 CCR Section 18982(a)(45) or further explained in 14 CCR Section  
 369 18995.4.
- 370 (tt) “Organic Waste” means Solid Wastes containing material originated from living  
 371 organisms and their metabolic waste products, including but not limited to food,  
 372 green material, landscape and pruning waste, organic textiles and carpets, lumber,  
 373 wood, Paper Products, Printing and Writing Paper, manure, biosolids, digestate,  
 374 and sludges or as otherwise defined in 14 CCR Section 18982(a)(46). Biosolids  
 375 and digestate are as defined by 14 CCR Section 18982(a).
- 376 (uu) “Organic Waste Generator” means a person or entity that is responsible for the  
 377 initial creation of Organic Waste, or as otherwise defined in 14 CCR Section  
 378 18982(a)(48).
- 379 (vv) “Paper Products” include, but are not limited to, paper janitorial supplies, cartons,  
 380 wrapping, packaging, file folders, hanging files, corrugated boxes, tissue, and  
 381 toweling, or as otherwise defined in 14 CCR Section 18982(a)(51).
- 382 (ww) “Printing and Writing Papers” include, but are not limited to, copy, xerographic,  
 383 watermark, cotton fiber, offset, forms, computer printout paper, white wove

384 envelopes, manila envelopes, book paper, note pads, writing tablets, newsprint,  
385 and other uncoated writing papers, posters, index cards, calendars, brochures,  
386 reports, magazines, and publications, or as otherwise defined in 14 CCR Section  
387 18982(a)(54).

388 (xx) "Prohibited Container Contaminants"

389 (1) For those generators provided with a three container collection system  
390 (blue, green and black): "Prohibited Container Contaminants" means the  
391 following: (i) discarded materials placed in the Blue Container that are not  
392 identified as acceptable Source Separated Recyclable Materials for the  
393 Jurisdiction's Blue Container; (ii) discarded materials placed in the Green  
394 Container that are not identified as acceptable Source Separated Green  
395 Container Organic Waste for the Jurisdiction's Green Container; (iii)  
396 discarded materials placed in the Black Container that are acceptable  
397 Source Separated Recyclable Materials and/or Source Separated Green  
398 Container Organic Wastes that belong in Jurisdiction's Green or Blue  
399 Container and (iv) Excluded Waste placed in any container.

400 (2) For those (limited commercial and MF) generators provided with two-  
401 container (blue/black) collection service for Source Separated Recyclable  
402 Materials and mixed materials): "Prohibited Container Contaminants"  
403 means the following: (i) discarded materials placed in a Blue Container that  
404 are not identified as acceptable Source Separated Recyclable Materials for  
405 Jurisdiction's Blue Container; (ii) discarded materials placed in the Black  
406 Container that are identified as acceptable Source Separated Recyclable  
407 Materials, which are to be separately collected in Jurisdiction's Blue  
408 Container; and, (iii) Excluded Waste placed in any container.

409 (yy) "Recovered Organic Waste Products" means products made from California,  
410 landfill-diverted recovered Organic Waste processed in a permitted or otherwise  
411 authorized facility, or as otherwise defined in 14 CCR Section 18982(a)(60).

412 (zz) "Recovery" means any activity or process described in 14 CCR Section  
413 18983.1(b), or as otherwise defined in 14 CCR Section 18982(a)(49).

414 (aaa) "Recycled-Content Paper" means Paper Products and Printing and Writing Paper  
415 that consists of at least 30 percent, by fiber weight, postconsumer fiber, or as  
416 otherwise defined in 14 CCR Section 18982(a)(61).

417 (bbb) "Regional Agency" means the South Bayside Waste Management Authority  
418 (SBWMA) as a regional agency as defined in Public Resources Code Section  
419 40181.

420 (ccc) "Remote Monitoring" means the use of the internet of things (IoT) and/or wireless  
421 electronic devices to visualize the contents of Blue Containers, Green Containers,

422 and Black Containers for purposes of identifying the quantity of materials in  
423 containers (level of fill) and/or presence of Prohibited Container Contaminants.

424 (ddd) “Renewable Gas” means gas derived from Organic Waste that has been diverted  
425 from a California landfill and processed at an in-vessel digestion facility that is  
426 permitted or otherwise authorized by 14 CCR to recycle Organic Waste, or as  
427 otherwise defined in 14 CCR Section 18982(a)(62).

428 (eee) “Restaurant” means an establishment primarily engaged in the retail sale of food  
429 and drinks for on-premises or immediate consumption, or as otherwise defined in  
430 14 CCR Section 18982(a)(64).

431 (fff) “SB 1383” means Senate Bill 1383 of 2016 approved by the Governor on  
432 September 19, 2016, which added Sections 39730.5, 39730.6, 39730.7, and  
433 39730.8 to the Health and Safety Code, and added Chapter 13.1 (commencing  
434 with Section 42652) to Part 3 of Division 30 of the Public Resources Code,  
435 establishing methane emissions reduction targets in a Statewide effort to reduce  
436 emissions of short-lived climate pollutants as amended, supplemented,  
437 superseded, and replaced from time to time.

438 (ggg) “SB 1383 Eligible Mulch” means mulch eligible to meet the Annual Recovered  
439 Organic Waste Product Procurement Target, pursuant to 14 CCR Chapter 12 of  
440 Division 7. This SB 1383 Eligible Mulch shall meet the following conditions for the  
441 duration of the applicable procurement compliance year, as specified by 14 CCR  
442 Section 18993.1(f)(4):

- 443 1. Produced at one of the following facilities:
- 444 i. A compostable material handling operation or facility as defined in  
445 14 CCR Section 17852(a)(12), that is permitted or authorized under  
446 14 CCR Division 7, other than a chipping and grinding operation or  
447 facility as defined in 14 CCR Section 17852(a)(10).
  - 448 ii. A transfer/processing facility or transfer/processing operation as  
449 defined in 14 CCR Sections 17402(a)(30) and (31), respectively, that  
450 is permitted or authorized under 14 CCR Division 7; or,
  - 451 iii. A solid waste landfill as defined in Public Resources Code Section  
452 40195.1 that is permitted under 27 CCR Division 2.
- 453 2. Meet or exceed the physical contamination, maximum metal concentration,  
454 and pathogen density standards for land application specified in 14 CCR  
455 Sections 17852(a)(24.5)(A)1 through 3, as enforced with this ordinance.

456 **Guidance:** In order for mulch to qualify as a Recovered Organic Waste  
457 Product toward the Jurisdiction’s Annual Recovered Organic Waste Product  
458 Procurement Target, 14 CCR Section 18993.1 requires that Jurisdictions

459 adopt an ordinance or similarly enforceable mechanism to require  
460 compliance with the land application standards specified above.

461 (hhh) “SB 1383 Regulations” or “SB 1383 Regulatory” means or refers to, for the  
462 purposes of this ordinance, the Short-Lived Climate Pollutants: Organic Waste  
463 Reduction regulations developed by CalRecycle and adopted in 2020 that created  
464 14 CCR, Division 7, Chapter 12 and amended portions of regulations of 14 CCR  
465 and 27 CCR.

466 Guidance: “14 CCR” means Title 14 of the California Code of Regulations, and “27  
467 CCR” means Title 27 of the California Code of Regulations.

468 (iii) SBWMA means the South Bayside Waste Management Authority, a regional  
469 agency, as defined in Public Resources Section 40181, serving its member  
470 agencies on recycling and waste issues.

471 (jjj) “Self-Hauler” means a person, who hauls Solid Waste, Organic Waste or  
472 recyclable material he or she has generated to another person. Self-hauler also  
473 includes a person who back-hauls waste, or as otherwise defined in 14 CCR  
474 Section 18982(a)(66). Back-haul means generating and transporting Organic  
475 Waste to a destination owned and operated by the generator using the generator’s  
476 own employees and equipment, or as otherwise defined in 14 CCR Section  
477 18982(a)(66)(A). “Self-Hauler” for the purposes of Edible food recovery, means a  
478 commercial edible food generator who holds a contract with and hauls edible food  
479 to a Food Recovery Organization or other site for redistribution according to the  
480 requirements of this ordinance.

481 (kkk) “Single-Family” means of, from, or pertaining to any residential premises with fewer  
482 than five (5) units.

483 (lll) “Solid Waste” has the same meaning as defined in State Public Resources Code  
484 Section 40191, which defines Solid Waste as all putrescible and nonputrescible  
485 solid, semisolid, and liquid wastes, including garbage, trash, refuse, paper,  
486 rubbish, ashes, industrial wastes, demolition and construction wastes, abandoned  
487 vehicles and parts thereof, discarded home and industrial appliances, dewatered,  
488 treated, or chemically fixed sewage sludge which is not hazardous waste, manure,  
489 vegetable or animal solid and semi-solid wastes, and other discarded solid and  
490 semisolid wastes, with the exception that Solid Waste does not include any of the  
491 following wastes:

492 (1) Hazardous waste, as defined in the State Public Resources Code Section  
493 40141.

494 (2) Radioactive waste regulated pursuant to the State Radiation Control Law  
495 (Chapter 8 (commencing with Section 114960) of Part 9 of Division 104 of  
496 the State Health and Safety Code).

497 (3) Medical waste regulated pursuant to the State Medical Waste Management  
498 Act (Part 14 (commencing with Section 117600) of Division 104 of the State  
499 Health and Safety Code). Untreated medical waste shall not be disposed of  
500 in a Solid Waste landfill, as defined in State Public Resources Code Section  
501 40195.1. Medical waste that has been treated and deemed to be Solid  
502 Waste shall be regulated pursuant to Division 30 of the State Public  
503 Resources Code.

504 (mmm) "Source Separated" means materials, including commingled recyclable  
505 materials, that have been separated or kept separate from the Solid Waste stream,  
506 at the point of generation, for the purpose of additional sorting or processing those  
507 materials for recycling or reuse in order to return them to the economic mainstream  
508 in the form of raw material for new, reused, or reconstituted products, which meet  
509 the quality standards necessary to be used in the marketplace, or as otherwise  
510 defined in 14 CCR Section 17402.5(b)(4). For the purposes of the ordinance,  
511 Source Separated shall include separation of materials by the generator, property  
512 owner, property owner's employee, property manager, or property manager's  
513 employee into different containers for the purpose of collection such that Source  
514 Separated materials are separated from Black container Waste or other Solid  
515 Waste for the purposes of collection and processing.

516 (nnn) "Source Separated Blue Container Organic Waste" means Source Separated  
517 Organic Wastes that can be placed in a Blue Container including clean paper and  
518 cardboard.

519 (ooo) "Source Separated Green Container Organic Waste" means Source Separated  
520 Organic Waste that can be placed in a Green Container that is specifically intended  
521 for the separate collection of Organic Waste, excluding Source Separated Blue  
522 Container Organic Waste, carpets, Non-Compostable Paper, and textiles.  
523 Acceptable materials include food scraps, food soiled paper, plants and bio-  
524 plastics labeled BPI Certified Compostable.

525 (ppp) "Source Separated Recyclable Materials" means Source Separated Non-Organic  
526 Recyclables and Source Separated Blue Container Organic Waste and includes  
527 clean paper and cardboard, glass bottles, cans and plastic bottles, tubs and  
528 containers.

529 (qqq) "State" means the State of California.

530 (rrr) "Supermarket" means a full-line, self-service retail store with gross annual sales of  
531 two million dollars (\$2,000,000), or more, and which sells a line of dry grocery,  
532 canned goods, or nonfood items and some perishable items, or as otherwise  
533 defined in 14 CCR Section 18982(a)(71).

534 (sss) "Tier One Commercial Edible Food Generator" means a Commercial Edible Food  
535 Generator that is one of the following:

536 (1) Supermarket.

537 (2) Grocery Store with a total facility size equal to or greater than 10,000 square  
538 feet.

539 (3) Food Service Provider.

540 (4) Food Distributor.

541 (5) Wholesale Food Vendor.

542 If the definition in 14 CCR Section 18982(a)(73) of Tier One Commercial Edible  
543 Food Generator differs from this definition, the definition in 14 CCR Section  
544 18982(a)(73) shall apply to this ordinance.

545 (ttt) "Tier Two Commercial Edible Food Generator" means a Commercial Edible Food  
546 Generator that is one of the following:

547 (1) Restaurant with 250 or more seats, or a total facility size equal to or greater  
548 than 5,000 square feet.

549 (2) Hotel with an on-site Food Facility and 200 or more rooms.

550 (3) Health facility with an on-site Food Facility and 100 or more beds.

551 (4) Large Venue.

552 (5) Large Event.

553 (6) A State agency with a cafeteria with 250 or more seats or total cafeteria  
554 facility size equal to or greater than 5,000 square feet.

555 (7) A Local Education Agency facility with an on-site Food Facility.

556 If the definition in 14 CCR Section 18982(a)(74) of Tier Two Commercial Edible  
557 Food Generator differs from this definition, the definition in 14 CCR Section  
558 18982(a)(74) shall apply to this ordinance.

559 (uuu) "Wholesale Food Vendor" means a business or establishment engaged in the  
560 merchant wholesale distribution of food, where food (including fruits and  
561 vegetables) is received, shipped, stored, prepared for distribution to a retailer,  
562 warehouse, distributor, or other destination, or as otherwise defined in 14 CCR  
563 Section 189852(a)(76).

#### 564 **SECTION 4. REQUIREMENTS FOR SINGLE-FAMILY GENERATORS**

565 Single-Family Organic Waste Generators shall comply with the following requirements  
566 except Single-Family generators that meet the Self-Hauler requirements in Section 10 of  
567 this ordinance:

568 Guidance: Include the text highlighted above only if the Jurisdiction allows Single-Family  
569 generators to self-haul materials they generate. By virtue of adding this language and  
570 requirements on Self-Haulers in Section 10, Jurisdiction is thereby allowing self-hauling,  
571 and creating the required enforceable mechanism for self-hauling, as required in 14 CCR  
572 Section 18988.1(b).

573 (a) Shall subscribe to Jurisdiction’s Organic Waste collection services for all Organic  
574 Waste generated as described below in Section 4(b). Jurisdiction shall have the  
575 right to review the number and size of a generator’s containers to evaluate  
576 adequacy of capacity provided for each type of collection service for proper  
577 separation of materials and containment of materials; and, Single-Family  
578 generators shall adjust its service level for its collection services as requested by  
579 the Jurisdiction. Generators may additionally manage their Organic Waste by  
580 preventing or reducing their Organic Waste, managing Organic Waste on site,  
581 and/or using a Community Composting site pursuant to 14 CCR Section  
582 18984.9(c).

583 (b) Shall participate in the Jurisdiction’s three container Organic Waste collection  
584 service(s) by placing designated materials in designated containers as described  
585 below, and shall not place Prohibited Container Contaminants in collection  
586 containers.

587 Generator shall place Source Separated Green Container Organic Waste,  
588 including Food Waste, in the Green Container; Source Separated blue  
589 container organic waste and recyclable Materials in the Blue Container; and  
590 Black container Waste in the Black container, per jurisdictional and collector  
591 guidelines. Generators shall not place materials designated for the Black  
592 container into the Green Container or Blue Container.

## 593 **SECTION 5. REQUIREMENTS FOR COMMERCIAL BUSINESSES**

594 Note that Commercial Businesses includes Multi-Family Residential Dwellings of five (5)  
595 and more units.

596 Generators that are Commercial Businesses, including Multi-Family Residential  
597 Dwellings, shall:

598 (a) Subscribe to Jurisdiction’s three container collection services and comply with  
599 requirements of those services as described below in Section 5(b), **except**  
600 **Commercial Businesses that meet the Self-Hauler requirements in Section 10 of this**  
601 **ordinance.** Jurisdiction shall have the right to review the number and size of a  
602 generator’s containers and frequency of collection to evaluate adequacy of capacity  
603 provided for each type of collection service for proper separation of materials and  
604 containment of materials; and, Commercial Businesses shall adjust their service level  
605 for their collection services as requested by the Jurisdiction.



606 Guidance: Include the highlighted phrase in the preceding sentence if the Jurisdiction  
607 allows commercial businesses to self-haul materials they generate. By virtue of adding  
608 this language and requirements on Self-Haulers in Section 10, Jurisdiction is thereby  
609 allowing self-hauling, and creating the required enforceable mechanism for self-  
610 hauling, as required in 14 CCR Section 18988.1(b).

611 (b) Participate in the Jurisdiction’s Organic Waste collection service(s) by placing  
612 designated materials in designated containers as described below. Commercial  
613 businesses that meet the self-hauler requirements in Section 10 of this ordinance  
614 are excluded from this requirement.

615 Guidance: Include highlighted sentence above if jurisdiction allows self hauling.

616 (A) Generator shall place Source Separated Green Container Organic  
617 Waste, including Food Waste, in the Green Container; Source  
618 Separated Blue container organic waste and source separated  
619 Recyclable Materials in the Blue Container; and Black container  
620 Waste in the Black container. Generator shall not place materials  
621 designated for the Black container into the Green Container or Blue  
622 Container.

623 (B) Generators that are offered two container service (this will be limited  
624 to a specified number of commercial and MF generators on an  
625 invitation only basis, based on waste quantities and type, and  
626 availability of new organics to energy processing system) shall place  
627 only source separated blue container organic waste and source  
628 separated recyclable materials in a blue container and all other  
629 materials (mixed waste) in a black container.

630 (c) Supply and allow access to an adequate number, size and location of collection  
631 containers with sufficient labels or colors (conforming with Sections 5(d)(1) and  
632 5(d)(2) below) for employees, contractors, tenants, and customers, consistent with  
633 Jurisdiction’s Blue Container, Green Container, and Black container collection  
634 service or, if self-hauling, per the Commercial Businesses’ instructions to support  
635 its compliance with its self-haul program, in accordance with Section 10.

636 (d) Excluding Multi-Family Residential Dwellings, provide containers for the collection  
637 of Source Separated Green Container Organic Waste and Source Separated  
638 Recyclable Materials in all indoor and outdoor areas where disposal containers are  
639 provided for customers, for materials generated by that business. Such containers  
640 do not need to be provided in restrooms. If a Commercial Business does not  
641 generate any of the materials that would be collected in one type of container, then  
642 the business does not have to provide that particular container in all areas where  
643 disposal containers are provided for customers. Pursuant to 14 CCR Section  
644 18984.9(b), the containers provided by the business shall have either:

- 645 (1) A body or lid that conforms with the container colors provided through the  
646 collection service provided by Jurisdiction, with either lids conforming to the  
647 color requirements or bodies conforming to the color requirements or both  
648 lids and bodies conforming to color requirements. A Commercial Business  
649 is not required to replace functional containers, including containers  
650 purchased prior to January 1, 2022, that do not comply with the  
651 requirements of the subsection prior to the end of the useful life of those  
652 containers, or prior to January 1, 2036, whichever comes first.
- 653 (2) Container labels that include language or graphic images, or both, indicating  
654 the primary material accepted and the primary materials prohibited in that  
655 container, or containers with imprinted text or graphic images that indicate  
656 the primary materials accepted and primary materials prohibited in the  
657 container. Pursuant 14 CCR Section 18984.8, the container labeling  
658 requirements are required on new containers commencing January 1, 2022.
- 659 (e) Multi-Family Residential Dwellings are not required to comply with container  
660 placement requirements or labeling requirement in Section 5(d) pursuant to 14  
661 CCR Section 18984.9(b).
- 662 (f) To the extent practical through education, training, Inspection, and/or other  
663 measures, excluding Multi-Family Residential Dwellings, prohibit employees from  
664 placing materials in a container not designated for those materials per the  
665 Jurisdiction's Blue Container, Green Container, and Black container collection  
666 service or, if self-hauling, per the Commercial Businesses' instructions to support  
667 its compliance with its self-haul program, in accordance with Section 10.
- 668 (g) Excluding Multi-Family Residential Dwellings, annually inspect Blue Containers,  
669 Green Containers, and Black containers for contamination and inform employees  
670 if containers are contaminated and of the requirements to keep contaminants out  
671 of those containers pursuant to 14 CCR Section 18984.9(b)(3).
- 672 (h) Annually provide information to employees, contractors, tenants, and customers  
673 about Organic Waste Recovery requirements and about proper sorting of Source  
674 Separated Green Container Organic Waste and Source Separated Recyclable  
675 Materials.
- 676 (i) Provide education information before or within fourteen (14) days of occupation of  
677 the premises to new tenants that describes requirements to keep Source  
678 Separated Green Container Organic Waste and Source Separated Recyclable  
679 Materials separate from Black container Waste (when applicable) and the location  
680 of containers and the rules governing their use at each property.
- 681 (j) Provide or arrange access for Jurisdiction or its agent to their properties during all  
682 Inspections conducted in accordance with Section 14 of this ordinance to confirm  
683 compliance with the requirements of this ordinance.

- 684 (k) Accommodate and cooperate with Jurisdiction’s Remote Monitoring program for  
685 Inspection of the contents of containers for Prohibited Container Contaminants,  
686 which may be implemented at a later date, to evaluate generator’s compliance with  
687 Section 5(b). Should a remote monitoring program be used by the jurisdiction it  
688 shall involve installation of Remote Monitoring equipment on or in the Blue  
689 Containers, Green Containers, and Black containers.
- 690 (l) At Commercial Business’s option and subject to any approval required from the  
691 Jurisdiction, implement a Remote Monitoring program for Inspection of the  
692 contents of its Blue Containers, Green Containers, and Black containers for the  
693 purpose of monitoring the contents of containers to determine appropriate levels  
694 of service and to identify Prohibited Container Contaminants. Generators may  
695 install Remote Monitoring devices on or in the Blue Containers, Green Containers,  
696 and Black containers subject to written notification to or approval by the Jurisdiction  
697 or its Designee.
- 698 (m) If a Commercial Business wants to self haul, meet the Self-Hauler requirements in  
699 Section 10 of this ordinance.
- 700 (n) Nothing in this Section prohibits a generator from preventing or reducing waste  
701 generation, managing Organic Waste on site, or using a Community Composting  
702 site pursuant to 14 CCR Section 18984.9(c).
- 703 (o) Commercial Businesses that are Tier One or Tier Two Commercial Edible Food  
704 Generators shall comply with Edible Food Recovery requirements, pursuant to the  
705 Edible Food Recovery provisions of this ordinance in Section 7.

706 **SECTION 6. WAIVERS FOR GENERATORS**

707 Guidance: SB 1383 Regulations allow Jurisdictions, at their option, to grant waivers to  
708 generators for physical space limitations, de minimis volumes, and/or collection frequency  
709 waivers. However, if waivers are used SB 1383 specifies under what conditions they may  
710 be granted, as reflected in the language presented herein. A Jurisdiction may waive a  
711 Commercial Business’ obligation (including Multi-Family Residential Dwellings) to comply  
712 with some or all of the Organic Waste requirements of this ordinance if the Commercial  
713 Business provides specified documentation. Jurisdictions should delete any waivers they  
714 do not want to offer from (a), (b) and (c) below.

- 715 (a) De Minimis Waivers: The Jurisdiction may waive a Commercial Business’  
716 obligation (including Multi-Family Residential Dwellings) to comply with some or all of the  
717 Organic Waste requirements of this ordinance if the Commercial Business provides  
718 documentation that the business generates below a certain amount of Organic Waste  
719 material as described in Section 6(a)(2) below. Commercial Businesses requesting a de  
720 minimis waiver shall:

- 721 (1) Submit an application specifying the services that they are requesting a  
722 waiver from and provide documentation as noted below in (2) (A) or (B).
- 723 (2) Provide documentation that either:
- 724 (A) The Commercial Business' total Solid Waste collection service is two  
725 cubic yards or more per week and Organic Waste subject to  
726 collection in the Green Container comprises less than 20 gallons per  
727 week per applicable container of the business' total waste; or,
- 728 (B) The Commercial Business' total Solid Waste collection service is less  
729 than two cubic yards per week and Organic Waste subject to  
730 collection in the Green Container comprises less than 10 gallons per  
731 week per applicable container of the business' total waste.
- 732 (3) Notify Jurisdiction if circumstances change such that Commercial  
733 Business's Organic Waste exceeds threshold required for waiver, in which  
734 case waiver will be rescinded.
- 735 (4) Provide written verification of eligibility for de minimis waiver every 5 years,  
736 if Jurisdiction has approved de minimis waiver.
- 737 (b) Physical Space Waivers Jurisdiction may waive a Commercial Business' or  
738 property owner's obligations (including Multi-Family Residential Dwellings) to  
739 comply with some or all of the recyclable materials and/or Organic Waste collection  
740 service requirements if the Jurisdiction has evidence from its own staff, a hauler,  
741 licensed architect, or licensed engineer demonstrating that the premises lacks  
742 adequate space for the collection containers required for compliance with the  
743 Organic Waste collection requirements of Section 5.

744 Guidance: The type of evidence requested is required by regulations if physical space  
745 waivers are used. Note that Jurisdictions' authority to issue a waiver cannot be delegated  
746 to a private entity, such as their hauler, pursuant to the SB 1383 Regulations (14 CCR  
747 Section 18984.11(c)).

748 A Commercial Business or property owner may request a physical space waiver  
749 through the following process:

- 750 (1) Submit an application form specifying the type(s) of collection services for  
751 which they are requesting a compliance waiver.
- 752 (2) Provide documentation that the premises lacks adequate space for Blue  
753 Containers and/or Green Containers including documentation from its  
754 hauler, licensed architect, or licensed engineer.
- 755 (3) Provide written verification to Jurisdiction that it is still eligible for physical  
756 space waiver every five years, if Jurisdiction has approved application for a  
757 physical space waiver.

758 **SECTION 7. REQUIREMENTS FOR TIER ONE AND TIER TWO**  
759 **COMMERCIAL EDIBLE FOOD GENERATORS**

- 760 (a) Tier One Commercial Edible Food Generators must comply with the requirements  
761 of this Section 7 commencing January 1, 2022, and Tier Two Commercial Edible  
762 Food Generators must comply commencing January 1, 2024, pursuant to 14 CCR  
763 Section 18991.3.
- 764 (b) Large Venue or Large Event operators not providing food services, but allowing  
765 for food to be provided by others, shall require Food Facilities operating at the  
766 Large Venue or Large Event to comply with the requirements of this Section  
767 commencing January 1, 2024.
- 768 (c) Tier One and Tier Two Commercial Edible Food Generators shall comply with the  
769 following requirements:
- 770 (1) Arrange to recover the maximum amount of Edible Food that would  
771 otherwise be disposed.
- 772 (2) Use the CalRecycle Model Food Recovery Agreement or the contractual  
773 elements contained in the Requirements for Food Recovery Organizations  
774 and Food Recovery Services section of this Ordinance to contract with, or  
775 otherwise enter into a written agreement with Food Recovery Organizations  
776 or Food Recovery Services for:
- 777 (A) The collection of Edible Food for Edible Food Recovery from the Tier  
778 One or Tier Two Commercial Edible Food Generator’s premises; or,
- 779 (B) the acceptance of Edible Food that the Tier One or Tier Two  
780 Commercial Edible Food Generator self-hauls to the Food Recovery  
781 Organization.
- 782 (3) Contract with Food Recovery Organizations and Food Recovery Services  
783 able to demonstrate a positive reduction in greenhouse gas emissions from  
784 their Edible Food Recovery activity. A list of Food Recovery Organizations  
785 and Food Recovery Services is available on the County of San Mateo Office  
786 of Sustainability website.
- 787 (4) Shall not intentionally spoil Edible Food that is capable of being recovered  
788 by a Food Recovery Organization or a Food Recovery Service.
- 789 (5) Allow Jurisdiction’s enforcement entity or their Designee for Edible Food  
790 Recovery to access the premises and inspect procedures and review  
791 records related to Edible Food Recovery and/or provide them electronically  
792 if requested by the Jurisdiction or the Designee for Edible Food Recovery.
- 793 (6) Keep records that include the following information:

- 794 (A) A list of each Food Recovery Organization or a Food Recovery  
795 Service that collects or receives Edible Food from the Tier One or  
796 Tier Two Commercial Edible Food Generator pursuant to a contract  
797 or written agreement as required by this Ordinance.
- 798 (B) A copy of all contracts or written agreements established under the  
799 provisions of this Ordinance.
- 800 (C) A record of the following information for each of those Food Recovery  
801 Services or Food Recovery Organizations:
- 802 (i) The name, address and contact information of the Food  
803 Recovery Service or Food Recovery Organization.
- 804 (ii) The types of food that will be collected by or self-hauled to the  
805 Food Recovery Service or Food Recovery Organization.
- 806 (iii) The established schedule or frequency that food will be  
807 collected or self-hauled.
- 808 (iv) The quantity of food, measured in pounds recovered per  
809 month, collected or self-hauled to a Food Recovery Service or  
810 Food Recovery Organization for Food Recovery.
- 811 (7) No later than June 30th of each year commencing no later than July 1, 2022  
812 for Tier One Commercial Edible Food Generators and July 1, 2024 for Tier  
813 Two Commercial Edible Food Generators, they shall provide an annual  
814 Edible Food Recovery report to the Designee for Edible Food Recovery that  
815 includes, but is not limited to, the following information: a list of all contracts  
816 with Food Recovery Organizations and Food Recovery Services, the  
817 amount and type of Edible Food donated to Food Recovery Organizations  
818 and Food Recovery Services, the schedule of Edible Food pickup by Food  
819 Recovery Organizations and Food Recovery Services, a list of all types of  
820 Edible Food categories they generate, such as “baked goods,” that are not  
821 accepted by the Food Recovery Organizations and Food Recovery  
822 Services with whom they contract, the contact information for the manager  
823 and all staff responsible for Edible Food Recovery, and certification that all  
824 staff responsible for Edible Food Recovery have obtained a food handler  
825 card through an American National Standards Institute (ANSI) accredited  
826 training provider that meets ASTM International E2659-09 Standard  
827 Practice for Certificate Programs, such as ServSafe. With the exception of  
828 the food safety and handling training certification, Tier One and Tier Two  
829 Commercial Edible Food Generators may coordinate with their Edible Food  
830 Recovery contractors to supply this information. The Designee for Edible  
831 Food Recovery will assist in the preparation of these reports by providing  
832 guidance and a template located on the County of San Mateo Office of  
833 Sustainability website.

834 (8) Mandate their Edible Food Recovery staff learn and follow the donation  
835 guidelines and attend trainings conducted by Food Recovery Organizations  
836 or Food Recovery Services with which they contract regarding best  
837 practices and requirements for the timely identification, selection,  
838 preparation, and storage of Edible Food to ensure the maximum amount of  
839 Edible Food is recovered and to avoid supplying food for collection that is  
840 moldy, has been improperly stored, or is otherwise unfit for human  
841 consumption.

842 (9) Tier One and Tier Two Commercial Edible Food Generators who self-haul  
843 Edible Food shall require those transporting Edible Food for recovery to  
844 obtain a food handler card through an American National Standards  
845 Institute (ANSI) accredited training provider that meets ASTM International  
846 E2659-09 Standard Practice for Certificate Programs, such as ServSafe  
847 and follow the best practices and standards for proper temperature control,  
848 methods, and procedures for the safe handling and transport of food.

849 (d) Nothing in this Ordinance shall be construed to limit or conflict with the protections  
850 provided by the California Good Samaritan Food Donation Act of 2017, the Federal  
851 Good Samaritan Act, or share table and school food donation guidance pursuant  
852 to Senate Bill 557 of 2017 (approved by the Governor of the State of California on  
853 September 25, 2017, which added Article 13 [commencing with Section 49580] to  
854 Chapter 9 of Part 27 of Division 4 of Title 2 of the Education Code, and to amend  
855 Section 114079 of the Health and Safety Code, relating to food safety, as  
856 amended, supplemented, superseded and replaced from time to time).

857 **SECTION 8. REQUIREMENTS FOR FOOD RECOVERY**  
858 **ORGANIZATIONS AND SERVICES**

859 Guidance: The County of San Mateo's OOS has requested this specific language  
860 as requirements for jurisdictions to participate in the County OOS Edible Food  
861 Recovery Program. SB 1383 Regulations do not require (c) through (m) below,  
862 with the exception of an annual report from food recovery organizations and  
863 services.

864 (a) Food Recovery Services operating in the Jurisdiction and collecting or receiving  
865 Edible Food directly from Tier One and/or Tier Two Commercial Edible Food  
866 Generators via a contract or written agreement established under the requirements  
867 of this Ordinance, shall maintain the following records:

868 (1) The name, address, and contact information for each Tier One and Tier Two  
869 Commercial Edible Food Generator from which the service collects Edible  
870 Food.

871 (2) The quantity in pounds of Edible Food by type collected from each Tier One  
872 and Tier Two Commercial Edible Food Generator per month.

- 873 (3) The quantity in pounds of Edible Food by type transported to each Food  
874 Recovery Organization or redistribution site per month.
- 875 (4) The name, address, and contact information for each Food Recovery  
876 Organization or redistribution site that the Food Recovery Service  
877 transports Edible Food to for Edible Food Recovery.
- 878 (b) Food Recovery Organizations operating in the Jurisdiction and collecting or  
879 receiving Edible Food directly from Tier One and/or Tier Two Commercial Edible  
880 Food Generators via a contract or written agreement established under the  
881 requirements of this Ordinance, or receiving Edible Food from Food Recovery  
882 Services or from other Food Recovery Organizations, shall maintain the following  
883 records:
- 884 (1) The name, address, and contact information for each Tier One and Tier Two  
885 Commercial Edible Food Generator, Food Recovery Service, or other Food  
886 Recovery Organization from which the organization collects or receives  
887 Edible Food.
- 888 (2) The quantity in pounds of Edible Food by type collected or received from  
889 each Tier One or Tier Two Commercial Edible Food Generator, Food  
890 Recovery Service, or other Food Recovery Organization per month.
- 891 (3) The name, address, and contact information for other Food Recovery  
892 Organizations or redistribution sites that the Food Recovery Organization  
893 transports Edible Food to for Edible Food Recovery.
- 894 (c) Food Recovery Organizations and Food Recovery Services operating in the  
895 Jurisdiction shall inform Tier One and Tier Two Commercial Edible Food  
896 Generators from which they collect or receive Edible Food about California and  
897 Federal Good Samaritan Food Donation Act protection in written communications,  
898 such as in their contract or agreement established as required by this Ordinance.
- 899 (d) Commencing no later than July 1, 2022, Food Recovery Organizations and Food  
900 Recovery Services operating in the Jurisdiction and collecting or receiving Edible  
901 Food from Tier One and Tier Two Commercial Edible Food Generators or any  
902 other source shall report to the Designee for Edible Food Recovery the following:  
903 a detailed Edible Food activity report of the information collected as required under  
904 this Ordinance, including weight in pounds by type and source of Edible Food, the  
905 schedule/frequency of pickups/drop-offs of Edible Food from/to each Edible Food  
906 source or redistribution site, brief analysis of any necessary process improvements  
907 or additional infrastructure needed to support Edible Food Recovery efforts, such  
908 as training, staffing, refrigeration, vehicles, etc., and an up to date list of Tier One  
909 and Tier Two Commercial Edible Food Generators with whom they have contracts  
910 or agreements established as required under this Ordinance. The Designee for  
911 Edible Food Recovery will assist in the preparation of these reports by providing  
912 guidance and a template located on the County of San Mateo Office of



913 Sustainability website. This Edible Food activity report shall be submitted quarterly,  
914 or at the discretion of the Designee for Edible Food Recovery, less frequently, and  
915 shall cover the activity that occurred since the period of the last submission.

916 (e) Food Recovery Organizations and Food Recovery Services operating in the  
917 Jurisdiction shall contact the Designee for Edible Food Recovery to discuss the  
918 requirements of this Ordinance before establishing new contracts or agreements  
919 with Tier One or Tier Two Commercial Edible Food Generators and in order to  
920 maintain existing contracts or agreements for the recovery of Edible Food with  
921 Tier One and Tier Two Commercial Edible Food Generators.

922 (f) In order to provide the required records to the State, the Jurisdiction, or the  
923 Designee for Edible Food Recovery, and Tier One or Tier Two Commercial Edible  
924 Food Generators, contracts between Food Recovery Organizations and Food  
925 Recovery Services operating in the Jurisdiction and Tier One and Tier Two  
926 Commercial Edible Food Generators shall either:

927 (1) Use the Model Food Recovery Agreement developed by the State of  
928 California's Department of Resources Recycling and Recovery  
929 (CalRecycle,) and include a clause requiring the Food Recovery  
930 Organization or Food Recovery Service to report to the Tier One and Tier  
931 Two Commercial Edible Food Generators with whom they have contracts  
932 the annual amount of Edible Food recovered and to inform them of the tax  
933 benefits available to those who donate Edible Food to non-profits

934 (2) Or include in their contracts the following elements:

935 (A) List/description of allowable foods the Food Recovery  
936 Organization/Food Recovery Service will receive.

937 (B) List/description of foods not accepted by the Food Recovery  
938 Organization/Food Recovery Service.

939 (C) Conditions for refusal of food.

940 (D) Food safety requirements, training, and protocols.

941 (E) Transportation and storage requirements and training.

942 (F) A protocol for informing the Tier One or Tier Two Commercial  
943 Edible Food Generators of a missed or delayed pickup.

944 (G) Notice that donation dumping is prohibited.

945 (H) Provisions to collect sufficient information to meet the record-  
946 keeping requirements of this Ordinance.

947 (I) Fees/financial contributions/acknowledgement of terms for  
948 the pickup and redistribution of Edible Food.

949 (J) Terms and conditions consistent with the CalRecycle Model  
950 Food Recovery Agreement.

951 (K) Information supplying the Tier One or Tier Two Commercial  
952 Edible Food Generators with the annual amount of Edible  
953 Food recovered and informing them of the tax benefits that  
954 may be available to those who donate Edible Food to non-  
955 profits.

956 (L) Contact name, address, phone number, and email for both  
957 responsible parties, including the current on-site staff  
958 responsible for Edible Food Recovery.

959 (M) Food Recovery Organizations accepting self-hauling of Edible  
960 Food from Tier One and Tier Two Commercial Edible Food  
961 Generators must provide a schedule, including days of the  
962 week and acceptable times for drop-offs, and information  
963 about any limitation on the amount of food accepted, and/or  
964 the packaging requirements or other conditions of transport,  
965 such as, but not limited to, maintaining proper temperature  
966 control, and other requirements for the safe handling and  
967 transport of food, the self-hauler must follow for the Edible  
968 Food to be accepted.

969 (g) Food Recovery Organizations and Food Recovery Services operating in the  
970 Jurisdiction shall demonstrate that all persons, including volunteers and contracted  
971 workers using their own vehicle, involved in the handling or transport of Edible  
972 Food, have obtained a food handler card through an American National Standards  
973 Institute (ANSI) accredited training provider that meets ASTM International E2659-  
974 09 Standard Practice for Certificate Programs, such as ServSafe.

975 (h) Food Recovery Organizations and Food Recovery Services operating in the  
976 Jurisdiction shall use the appropriate temperature control equipment and methods  
977 and maintain the required temperatures for the safe handling of Edible Food  
978 recovered from Tier One and Tier Two Commercial Edible Food Generators for  
979 the duration of the transportation of the Edible Food for redistribution, including  
980 Edible Food transported by private vehicles.

981 (i) In order to ensure recovered Edible Food is eaten and to prevent donation  
982 dumping, Food Recovery Organizations and Food Recovery Services operating in  
983 the Jurisdiction shall provide documentation that all redistribution sites which are  
984 not themselves Food Recovery Organizations to which they deliver Edible Food  
985 have a feeding or redistribution program in place to distribute, within a reasonable  
986 time, all the Edible Food they receive. Such documentation may include a website

987 address which explains the program or pamphlets/brochures prepared by the  
988 redistribution site.

989 (j) Food Recovery Organizations and Food Recovery Services operating in the  
990 Jurisdiction unable to demonstrate a positive reduction in GHG emissions for their  
991 Edible Food Recovery operational model cannot contract with Tier One and Tier  
992 Two Commercial Edible Food Generators in the Jurisdiction for the purpose of  
993 recovering Edible Food as defined in this Ordinance. Food Recovery  
994 Organizations and Food Recovery Services contracting to recover Edible Food  
995 from a Tier One and Tier Two Commercial Edible Food Generator for redistribution  
996 shall consult with the Jurisdiction's Designee for Edible Food Recovery to  
997 document that their overall operational model will achieve a greenhouse gas  
998 emissions reduction. Such review may analyze route review, miles traveled for  
999 pick-up and redistribution, amount of food rescued, and the likelihood of  
1000 consumption after redistribution.

1001 (k) Food Recovery Organizations and Food Recovery Services operating in the  
1002 Jurisdiction shall visually inspect all Edible Food recovered or received from a Tier  
1003 One and Tier Two Commercial Edible Food Generator. If significant spoilage is  
1004 found, or if the food is otherwise found to be unfit for redistribution for human  
1005 consumption, Food Recovery Organizations and Food Recovery Services shall  
1006 immediately notify the Designee for Edible Food Recovery using the process found  
1007 on the County of San Mateo Office of Sustainability's website. The notice shall  
1008 include:

1009 (1) The type and amount, in pounds, of spoiled food or food unfit for  
1010 redistribution for human consumption, or provide a photographic record of  
1011 the food, or both.

1012 (2) The date and time such food was identified.

1013 (3) The name, address and contact information for the Tier One or Tier Two  
1014 Commercial Edible Food Generator which provided the food.

1015 (4) The date and time the food was picked up or received.

1016 (5) A brief explanation of why the food was rejected or refused.

1017 (l) Contracts between Tier One or Tier Two Commercial Edible Food Generators and  
1018 Food Recovery Organizations or Food Recovery Services shall not include any  
1019 language prohibiting Tier One or Tier Two Commercial Edible Food Generators  
1020 from contracting or holding agreements with multiple Food Recovery  
1021 Organizations or Food Recovery Services listed on the County of San Mateo Office  
1022 of Sustainability website.

1023 (m) Food Recovery Organizations and Food Recovery Services operating in the  
1024 Jurisdiction shall conduct trainings and develop educational material such as  
1025 donation guidelines and handouts to provide instruction and direction to Tier One

1026 and Tier Two Commercial Edible Food Generators with whom they contract  
1027 regarding best practices and requirements for the timely identification, selection,  
1028 preparation, and storage of Edible Food to ensure the maximum amount of Edible  
1029 Food is recovered and to avoid the collection of food that is moldy, has been  
1030 improperly stored, or is otherwise unfit for human consumption.

1031 (n) Edible Food Recovery Capacity Planning

1032 (1) Food Recovery Services and Food Recovery Organizations. In order to  
1033 support Edible Food Recovery capacity planning assessments or other  
1034 such studies, Food Recovery Services and Food Recovery Organizations  
1035 operating in the Jurisdiction shall provide information and consultation to  
1036 the Jurisdiction and its Designee for Edible Food Recovery upon request,  
1037 regarding existing, or proposed new or expanded, Edible Food Recovery  
1038 capacity that could be accessed by the Jurisdiction and its Tier One and  
1039 Tier Two Commercial Edible Food Generators. A Food Recovery Service  
1040 or Food Recovery Organization contacted by the Jurisdiction or its  
1041 Designee for Edible Food Recovery shall respond to such requests for  
1042 information within 60 days.

1043 Guidance: SB 1383 Regulations (14 CCR Section 18992.2) require that counties  
1044 conduct Edible Food Recovery capacity planning, in coordination with Jurisdictions  
1045 and Regional Agencies, and consult with Food Recovery Organizations and  
1046 services regarding existing, or proposed new and expanded, capacity that could  
1047 be accessed by the Jurisdiction and its Commercial Edible Food Generators.  
1048 Entities contacted by a Jurisdiction shall respond within 60 days regarding  
1049 available and potential new or expanded capacity, pursuant to 14 CCR Section  
1050 18992.2(b), or another timeframe could be inserted within the ordinance that is  
1051 less than 60 days, but this is not required.

1052 (o) Allow Jurisdiction's enforcement entity or their Designee for Edible Food Recovery  
1053 to access the premises and inspect procedures and review records related to  
1054 Edible Food Recovery and/or provide them electronically if requested by the  
1055 Jurisdiction or the Designee for Edible Food Recovery.

1056 (2) Provision for County ordinance only:

1057 Guidance: SB 1383 Regulations require that counties conduct Food Recovery  
1058 capacity planning in coordination with cities, special districts that provide solid  
1059 waste collection services, and Regional Agencies within the county. The Cities,  
1060 special district and Authority should be aware of their requirement to conduct  
1061 capacity planning in coordination with the County.

1062 Cities, special districts that provide solid waste collection services, and  
1063 regional agencies located within the County shall conduct Edible Food  
1064 Recovery capacity planning, in coordination with the County.

1065 (A) If the County identifies that new or expanded capacity to recover  
1066 Edible Food is needed, then each Jurisdiction within the County that  
1067 lacks capacity shall:

1068 (i) Submit an implementation schedule to CalRecycle and the  
1069 County that demonstrates how it will ensure there is enough  
1070 new or expanded capacity to recover the Edible Food  
1071 currently disposed by Commercial Edible Food Generators  
1072 within its Jurisdiction by the end of the reporting period set  
1073 forth in 14 CCR Section 18992.3. The implementation  
1074 schedule shall include the information specified in 14 CCR  
1075 Section 18992.2(c)(1)(A).

1076 (ii) Consult with Food Recovery Organizations and Food  
1077 Recovery Services regarding existing, or proposed new and  
1078 expanded capacity that could be accessed by the Jurisdiction  
1079 and its Commercial Edible Food Generators.

1080 (B) If the County finds that new or expanded capacity is needed, the  
1081 County shall notify the Jurisdiction(s) that lack sufficient capacity.

1082 (C) A City, West Bay Sanitary District, or SBWMA contacted by the  
1083 County pursuant to this Section shall respond to the County's request  
1084 for information within 120 days of receiving the request from the  
1085 County,

1086 Guidance: If a City, West Bay Sanitary District or SBWMA fails to provide  
1087 the necessary information within 120 days, the County is not required to  
1088 include estimates for that Jurisdiction in its capacity plan in the report it  
1089 submits pursuant to 14 CCR Section 18992.3.

1090 **SECTION 9. REQUIREMENTS FOR HAULERS AND FACILITY**  
1091 **OPERATORS**

1092 (a) Requirements for Haulers

1093 Guidance: This Section addresses specific regulatory requirements that  
1094 Jurisdictions must enforce on haulers and other entities as specified in 14 CCR,  
1095 Division 7, Chapter 12, Article 7. There are other requirements in the SB 1383  
1096 Regulations on the Jurisdiction that the Jurisdiction may delegate to a hauler to  
1097 comply with on their behalf such as Container Contamination requirements,  
1098 outreach and education requirements, container color requirements, and container  
1099 labeling requirements. Some of these requirements are more appropriately  
1100 addressed in franchise agreements, hauler permits, or licensing systems.

1101 **Option 1: Exclusive franchised hauler**

- 1102           Option 2: Non-exclusive franchised haulers
- 1103           Option 3: Permitted haulers
- 1104           Option 4: Licensed haulers
- 1105           Option 5: Include a combination of Options 1 through 4 as appropriate
- 1106           (1)   Exclusive Franchised hauler and \_\_\_\_\_ (Jurisdiction to insert other  
1107           type(s) of hauler(s) from list above, if allowed) providing residential,  
1108           Commercial, or industrial Organic Waste collection services to generators  
1109           within the Jurisdiction’s boundaries shall meet the following requirements  
1110           and standards as a condition of approval of a contract, agreement, or other  
1111           authorization with the Jurisdiction to collect Organic Waste:
- 1112                   (A)   Through written notice to the Jurisdiction annually on or before  
1113                   January 31, \_\_\_\_\_ (Jurisdiction to insert date), identify, for customers  
1114                   with three container collection, the facilities to which they will  
1115                   transport Organic Waste including facilities for Source Separated  
1116                   Recyclable Materials and Source Separated Green Container  
1117                   Organic Wastes and black container waste.
- 1118                   Through written notice to the Jurisdiction annually on or before  
1119                   January 31, identify, for customers with two container collection  
1120                   system, the facilities to which they will transport Source Separated  
1121                   Recyclable Materials and black container waste,
- 1122                   (B)   For customers with three container collection, transport Source  
1123                   Separated Blue Container Waste to a facility that recovers those  
1124                   materials and Source Separated Green Container Organic Waste to  
1125                   a facility, operation, activity, or property that recovers Organic Waste  
1126                   as defined in 14 CCR, Division 7, Chapter 12, Article 2.
- 1127                   For customers with two container collection, transport Source  
1128                   Separated Blue Container Waste to a facility that recovers those  
1129                   materials and black container waste to a high diversion organic  
1130                   waste processing facility.
- 1131                   (C)   Obtain approval from the Jurisdiction to haul Organic Waste, unless  
1132                   it is transporting Source Separated Organic Waste to a Community  
1133                   Composting site or lawfully transporting C&D in a manner that  
1134                   complies with 14 CCR Section 18989.1, Section 11 of this ordinance,  
1135                   and Jurisdiction’s C&D ordinance.
- 1136           (2)   Franchised hauler (Insert any other type of haulers approved from options  
1137           listed above) with authorization to collect Organic Waste shall comply with  
1138           education, equipment, signage, container labeling, container color,  
1139           contamination monitoring, reporting, and other requirements contained

1140 within its franchise agreement, permit, license, or other agreement entered  
1141 into with Jurisdiction.

1142 (b) Requirements for Facility Operators and Community Composting Operations

1143 (1) Owners of facilities, operations, and activities that recover Organic Waste,  
1144 including, but not limited to, Compost facilities, in-vessel digestion facilities,  
1145 and publicly-owned treatment works shall, upon Jurisdiction request,  
1146 provide information regarding available and potential new or expanded  
1147 capacity at their facilities, operations, and activities, including information  
1148 about throughput and permitted capacity necessary for planning purposes.  
1149 Entities contacted by the Jurisdiction shall respond within 60 days.

1150 Guidance: SB 1383 Regulations include specific requirements for processing and  
1151 facility standards. CalRecycle's Model Franchise Agreement Tool includes more  
1152 specific detail on those operative requirements for facilities. In addition to the  
1153 capacity planning requirements, Jurisdictions may consider including a reference  
1154 here to a franchise agreement, facility agreement, different section of the  
1155 Jurisdiction's municipal/County code, or other relevant document(s) where facility  
1156 standards are specified.

1157 (2) Community Composting operators, upon Jurisdiction request, shall provide  
1158 information to the Jurisdiction to support Organic Waste capacity planning,  
1159 including, but not limited to, an estimate of the amount of Organic Waste  
1160 anticipated to be handled at the Community Composting operation. Entities  
1161 contacted by the Jurisdiction shall respond within 60 days.

1162 **SECTION 10. SELF-HAULER REQUIREMENTS**

1163 Guidance: The SB 1383 Regulations (14 CCR Division 7, Chapter 12, Article 7) specify  
1164 requirements for Self-Haulers (which includes back-haulers per the Self-Hauler definition  
1165 of the SB 1383 Regulations). Jurisdictions that allow for self-hauling are required to adopt  
1166 an ordinance or other enforceable mechanism for Self-Hauler regulation requirements.  
1167 This Section 10 of the Model Ordinance provides language to document the Self-Hauler  
1168 regulations. If Jurisdictions do not allow self-hauling, this Section 10 may be deleted. If  
1169 self-hauling is allowed, this section will serve as the required ordinance for self hauling.  
1170 If jurisdiction has existing rules that differ or add on additional responsibilities to self  
1171 haulers, that policy, ordinance or code section should be referenced here.

1172 (a) Self-Haulers shall source separate all recyclable materials and Organic Waste  
1173 (materials that Jurisdiction otherwise requires generators to separate for collection  
1174 in the Jurisdiction's organics and recycling collection program) generated on-site  
1175 from Solid Waste in a manner consistent with 14 CCR Sections 18984.1 and  
1176 18984.2, or shall haul Organic Waste to a High Diversion Organic Waste  
1177 Processing Facility as specified in 14 CCR Section 18984.3.

1178 (b) Self-Haulers shall haul their Source Separated Recyclable Materials to a facility  
1179 that recovers those materials; and haul their Source Separated Green Container  
1180 Organic Waste to a Solid Waste facility, operation, activity, or property that  
1181 processes or recovers Source Separated Organic Waste. Alternatively, Self-  
1182 Haulers may haul Organic Waste to a High Diversion Organic Waste Processing  
1183 Facility.

1184 (c) Self-Haulers that are Commercial Businesses (including Multi-Family Residential  
1185 Dwellings) shall keep a record of the amount of Organic Waste delivered to each  
1186 Solid Waste facility, operation, activity, or property that processes or recovers  
1187 Organic Waste; this record shall be subject to Inspection by the Jurisdiction. The  
1188 records shall include the following information:

1189 (1) Delivery receipts and weight tickets from the entity accepting the waste.

1190 (2) The amount of material in cubic yards or tons transported by the generator  
1191 to each entity.

1192 (3) If the material is transported to an entity that does not have scales on-site,  
1193 or employs scales incapable of weighing the Self-Hauler's vehicle in a  
1194 manner that allows it to determine the weight of materials received, the Self-  
1195 Hauler is not required to record the weight of material but shall keep a record  
1196 of the entities that received the Organic Waste.

1197 (d) Self-Haulers that are Commercial Businesses (including Multi-Family Self-  
1198 Haulers) shall provide information collected in Section 10(c) to Jurisdiction if  
1199 requested.

1200 Guidance: This section (d) is optional. Self hauler reporting to the jurisdiction is not  
1201 required by the regs, but self hauler separation of materials and record keeping as  
1202 outlined in c above is required. Jurisdiction may include (d) above if it would like  
1203 to reserve the option to collect that information. If self haulers are required to  
1204 register with the jurisdiction, that should be added here

1205 (e) A residential Organic Waste Generator that self hauls Organic Waste is not  
1206 required to record or report information in Section 10(c) and (d).

1207 **SECTION 11. COMPLIANCE WITH CALGREEN RECYCLING**  
1208 **REQUIREMENTS**

1209 Guidance: SB 1383 Regulations (14 CCR Section 18989.1) require that a Jurisdiction,  
1210 which is a city, County, or a city and County, adopt an ordinance or other enforceable  
1211 requirement that requires compliance with C&D recycling requirements for Organic Waste  
1212 commingled with C&D and for provision of adequate space for recycling and organics for  
1213 Multi-Family and Commercial premises pursuant to Sections 4.408.1, 4.410.2, 5.408.1,  
1214 and 5.410.1 of the California Green Building Standards Code, 24 CCR, Part 11 as



1215 amended July 1, 2019 and effective January 1, 2020 (“CALGreen SB 1383 Baseline  
1216 Requirements”). These SB 1383 CALGreen related requirements only represent a subset  
1217 of all CALGreen requirements. This Section 11 provides example language that is  
1218 structured to fulfill this requirement related narrowly on the CALGreen SB 1383 Baseline  
1219 Requirements.

1220 SB 1383 Regulations (14 CCR Section 18989.1) cite specific date of effectiveness for  
1221 CALGreen of January 1, 2020. Jurisdictions’ ordinances need to meet or exceed these  
1222 CALGreen SB 1383 Baseline Requirements. If Jurisdictions have the ability to adopt an  
1223 ordinance that allows for an “auto” update of the Jurisdiction’s ordinance as the  
1224 CALGreen requirements change, that approach is allowable. Auto update should specify  
1225 that if any changes in CALGreen result in standards less than those in the SB 1383  
1226 CALGreen baseline requirements, then the SB 1383 CALGreen standards will be  
1227 maintained.

1228 Jurisdictions with an ordinance or similarly enforceable mechanism requiring compliance  
1229 with CALGreen can omit this Section. Jurisdictions should note that while these  
1230 CALGreen provisions are included in this Model Ordinance, a Jurisdiction may determine  
1231 it is more appropriate to include these CALGreen requirements in a separate ordinance  
1232 or in a different, more relevant municipal code section (e.g., building or planning code).  
1233 Also note that Jurisdictions are not required to address the CALGreen requirements  
1234 through an ordinance if they prefer to use another type of enforceable mechanism such  
1235 as through the building or planning code. In such case, Jurisdictions should delete this  
1236 Section.

1237 (a) Persons applying for a permit from the Jurisdiction for new construction and  
1238 building additions and alternations shall comply with the requirements of this  
1239 Section and all required components of the California Green Building Standards  
1240 Code, 24 CCR, Part 11, known as CALGreen, as amended, if its project is covered  
1241 by the scope of CALGreen **or more stringent requirements of the Jurisdiction**. If the  
1242 requirements of CALGreen are more stringent then the requirements of this  
1243 Section, the CALGreen requirements shall apply.

1244 Project applicants shall refer to Jurisdiction’s **building and/or planning code** for  
1245 complete CALGreen requirements.

1246 **Guidance: Jurisdictions should amend sentence above to reflect where an**  
1247 **applicant can find complete CALGreen requirements.**

1248 (b) For projects covered by CALGreen, the applicants must, as a condition of the  
1249 Jurisdiction’s permit approval, comply with the following:

1250 (1) Where five (5) or more Multi-Family dwelling units are constructed on a  
1251 building site, provide readily accessible areas that serve occupants of all  
1252 buildings on the site and are identified for the storage and collection of Blue  
1253 Container, Green Container and black container materials, consistent with  
1254 the three container collection program offered by the Jurisdiction, or comply

1255 with provision of adequate space for recycling for Multi-Family and  
1256 Commercial premises pursuant to Sections 4.408.1, 4.410.2, 5.408.1, and  
1257 5.410.1 of the California Green Building Standards Code, 24 CCR, Part 11  
1258 as amended provided amended requirements are more stringent than the  
1259 CALGreen requirements for adequate recycling space effective January 1,  
1260 2020. Guidance: Note that that the last portion of the requirement beginning  
1261 with "...or comply with provisions of adequate space..." is intended to create  
1262 an "auto-update" of the ordinance when CALGreen changes over time.  
1263 Jurisdictions may choose to eliminate this provision at their option, if they  
1264 prefer to update their ordinance each time CALGreen changes.

1265 (2) New Commercial construction or additions resulting in more than 30% of  
1266 the floor area shall provide readily accessible areas identified for the storage  
1267 and collection of Blue Container and Green Container materials, consistent  
1268 with the three container collection program offered by the Jurisdiction, or  
1269 shall comply with provision of adequate space for recycling for Multi-Family  
1270 and Commercial premises pursuant to Sections 4.408.1, 4.410.2, 5.408.1,  
1271 and 5.410.1 of the California Green Building Standards Code, 24 CCR, Part  
1272 11 as amended provided amended requirements are more stringent than  
1273 the CALGreen requirements for adequate recycling space effective January  
1274 1, 2020.

1275 (3) Comply with all applicable CALGreen requirements and applicable law  
1276 related to management of C&D, including diversion of Organic Waste in  
1277 C&D from disposal. Comply with Jurisdiction's C&D ordinance, **Section \_\_\_\_**  
1278 **of Jurisdiction's municipal code**, and all written and published Jurisdiction  
1279 policies and/or administrative guidelines regarding the collection, recycling,  
1280 diversion, tracking, and/or reporting of C&D. **Jurisdiction's C&D ordinance**  
1281 **can be found at this link: \_\_\_\_\_**

1282 Guidance: if jurisdiction has a C&D ordinance, add a link above.

## 1283 SECTION 12. MODEL WATER EFFICIENT LANDSCAPING 1284 ORDINANCE REQUIREMENTS

1285 Guidance: SB 1383 Regulations (14 CCR Section 18989.2) require that a Jurisdiction,  
1286 which is a city, County, or a City and County, adopt an ordinance or other enforceable  
1287 requirement that requires compliance with Sections 492.6(a)(3)(B) (C), (D), and (G) of the  
1288 MWELo as amended September 15, 2015 ("MWELo SB 1383 Baseline Requirements").  
1289 This Section 12 provides example language that is structured to fulfill this requirement  
1290 related narrowly on the MWELo SB 1383 Baseline Requirements. As a result, this section  
1291 does not broadly address all requirements of MWELo. Jurisdictions that already have a  
1292 compliant WELo or other enforceable mechanism, (such as enforceable requirements  
1293 through their planning or building code or landscape design review process) that cover  
1294 the MWELo SB 1383 Baseline Requirements, can delete this section.

1295 SB 1383 Regulations (14 CCR Section 18989.2) cite a specific date of effectiveness for  
1296 MWELo of September 15, 2015. Jurisdictions' ordinances need to meet or exceed these  
1297 MWELo SB 1393 Baseline Requirements. Including a provision that allows for an auto  
1298 update of the ordinance as MWELo requirements change, is allowable, which is included  
1299 below. If the "auto" update results in changes in MWELo with standards that are less  
1300 than those in the MWELo SB 1383 Baseline Requirements, then the Jurisdiction will need  
1301 to maintain the standards in the MWELo SB 1383 Baseline Requirements.

1302 (a) Property owners or their building or landscape designers, including anyone  
1303 requiring a building or planning permit, plan check, or landscape design review  
1304 from the Jurisdiction, who are constructing a new (Single-Family, Multi-Family,  
1305 public, institutional, or Commercial) project with a landscape area greater than 500  
1306 square feet, or rehabilitating an existing landscape with a total landscape area  
1307 greater than 2,500 square feet, shall comply with Sections 492.6(a)(3)(B) (C), (D),  
1308 and (G) of the MWELo, including sections related to use of Compost and mulch  
1309 as delineated in this Section 12.

1310 (b) The following Compost and mulch use requirements that are part of the MWELo  
1311 are now also included as requirements of this ordinance. Other requirements of  
1312 the MWELo are in effect and can be found in 23 CCR, Division 2, Chapter 2.7 and  
1313 in the jurisdiction's WELo, which can be found at \_\_\_\_\_.

1314 Guidance: In the preceding sentence, Jurisdictions can insert link to its own WELo  
1315 if the provisions are equal to or greater in stringency than Sections 492.6(a)(3)(B)  
1316 (C), (D), and (G) of the September 15, 2015 MWELo, but proof of these  
1317 requirements will need to be submitted to CalRecycle.

1318 (c) Property owners or their building or landscape designers that meet the threshold  
1319 for MWELo compliance outlined in Section 12(a) above shall:

1320 (1) Comply with Sections 492.6 (a)(3)(B)(C),(D) and (G) of the MWELo, which  
1321 requires the submittal of a landscape design plan with a soil preparation,  
1322 mulch, and amendments section to include the following:

1323 (A) For landscape installations, Compost at a rate of a minimum of four  
1324 cubic yards per 1,000 square feet of permeable area shall be  
1325 incorporated to a depth of six (6) inches into the soil. Soils with  
1326 greater than six percent (6%) organic matter in the top six (6) inches  
1327 of soil are exempt from adding Compost and tilling.

1328 (B) For landscape installations, a minimum three- (3-) inch layer of mulch  
1329 shall be applied on all exposed soil surfaces of planting areas except  
1330 in turf areas, creeping or rooting groundcovers, or direct seeding  
1331 applications where mulch is contraindicated. To provide habitat for  
1332 beneficial insects and other wildlife up to five percent (5%) of the  
1333 landscape area may be left without mulch. Designated insect habitat  
1334 must be included in the landscape design plan as such.

- 1335 (C) Organic mulch materials made from recycled or post-consumer  
 1336 materials shall take precedence over inorganic materials or virgin  
 1337 forest products unless the recycled post-consumer organic products  
 1338 are not locally available. Organic mulches are not required where  
 1339 prohibited by local fuel modification plan guidelines or other  
 1340 applicable local ordinances.
- 1341 (2) The MWELO compliance items listed in this Section are not an inclusive list  
 1342 of MWELO requirements; therefore, property owners or their building or  
 1343 landscape designers that meet the threshold for MWELO compliance  
 1344 outlined in Section 12(a) shall consult the full MWELO for all requirements.
- 1345 (d) If, after the adoption of this ordinance, the California Department of Water  
 1346 Resources, or its successor agency, amends 23 CCR, Division 2, Chapter 2.7,  
 1347 Sections 492.6(a)(3)(B) (C), (D), and (G) of the MWWELo September 15, 2015  
 1348 requirements in a manner that requires Jurisdictions to incorporate the  
 1349 requirements of an updated MWELO in a local ordinance, and the amended  
 1350 requirements include provisions more stringent than those required in this Section,  
 1351 the revised requirements of 23 CCR, Division 2, Chapter 2.7 shall be enforced.

1352 **SECTION 13. PROCUREMENT REQUIREMENTS FOR JURISDICTION**  
 1353 **DEPARTMENTS, DIRECT SERVICE PROVIDERS, AND VENDORS**

1354 Guidance: This Section of the Model Ordinance includes example procurement  
 1355 requirements to address the Recovered Organic Waste Product and Recycled-Content  
 1356 Paper procurement requirements pursuant to SB 1383 Regulations (14 CCR, Division 7,  
 1357 Chapter 12, Article 12). The first Section provides a simple statement of requirements for  
 1358 Jurisdiction’s departments to comply with the Jurisdiction’s purchasing policy, **if** the  
 1359 jurisdiction has a procurement policy or intends to adopt one. Procurement policies can  
 1360 be either adopted or amended to meet SB 1383 procurement regulatory requirements.

1361 Jurisdictions should note that while Recycled-Content Paper provisions are included in  
 1362 this Ordinance, a Jurisdiction may choose to include these requirements in a separate  
 1363 ordinance or policy or in a relevant municipal code section. Jurisdictions may use any  
 1364 type of enforceable mechanism to document the requirements, including a policy,  
 1365 ordinance and/or municipal code section.

1366 Requiring compliance with a separate procurement policy through this ordinance is one  
 1367 way to ensure that the provisions are enforceable, which is required for certain  
 1368 procurement provisions. For example, in order for mulch to qualify as a Recovered  
 1369 Organic Waste Product that the Jurisdiction may procure to comply with SB 1383  
 1370 Regulations (14 CCR Division 7, Chapter 12, Article 12), the Jurisdiction must have an  
 1371 enforceable ordinance, or similarly enforceable mechanism, that requires the mulch to  
 1372 meet certain standards, pursuant to 14 CCR Section 18993.1(f)(4).

1373 CalRecycle has a model procurement policy available on its website to assist jurisdiction's  
1374 in adopting a compliant procurement policy, should they choose to adopt one. That policy  
1375 is intended to help a jurisdiction meet its organic waste product procurement requirements  
1376 which go beyond recycled content paper procurement and include annual required  
1377 quantities for jurisdictional procurement of organic waste products. A separate  
1378 procurement policy could contain requirements that a Jurisdiction would place on its own  
1379 departments, purchasers, and contractors for procuring Compost, mulch, Renewable  
1380 Gas, electricity from biomass, and Recycled-Content Paper products and Printing and  
1381 Writing Paper and Recovered Organic Waste Products. Refer to the Additional  
1382 CalRecycle Resources section in the Guidance section of this Model for a link to the  
1383 Model Procurement Policy.

1384 (a) Jurisdiction departments, and direct service providers to the Jurisdiction, as  
1385 applicable, must comply with the Jurisdiction's Recovered Organic Waste Product  
1386 procurement policy adopted on \_\_\_\_\_ and Recycled-Content Paper  
1387 procurement policy adopted on \_\_\_\_\_ (Jurisdiction to amend the title(s) of the  
1388 "procurement policy(ies)" to reflect their title and insert date in the blank).

1389 Guidance: Jurisdictions may delete (a) if they do not plan on adopting a recovered  
1390 organic waste product procurement policy to address recovered organic waste  
1391 product procurement requirements and recycled content paper requirements in SB  
1392 1383 Regulations (14 CCR, Division 7, Chapter 12, Article 12). The purpose of this  
1393 statement is to identify the requirement for all Jurisdiction's departments and direct  
1394 service providers, if applicable, to comply with the policy(ies) and ensure the  
1395 policy(ies) is(are) enforceable.

1396 (b) All vendors providing Paper Products and Printing and Writing Paper shall:

1397 Guidance: This Section presents Recycled-Content Paper requirements for  
1398 Jurisdiction's vendors to support Jurisdiction's compliance with SB 1383  
1399 Regulations (14 CCR Section 18993.3). If Jurisdiction already has a procurement  
1400 policy, it may need to be updated to address the Recycled-Content Paper  
1401 procurement requirements in SB 1383 Regulations and to address Recovered  
1402 Organic Waste Product procurement.

1403 Section 22150 of the Public Contracts Code requires local governments to  
1404 purchase recycled products instead of non-recycled products whenever recycled  
1405 products are available at the same or a lesser total cost than non-recycled items,  
1406 if fitness and quality are equal. Jurisdictions are not prohibited from either using a  
1407 price preference (usually 5 to 10 percent) for Recycled-Content Paper or requiring  
1408 Recycled-Content Paper regardless of price. The options are presented below for  
1409 consideration.

1410 (1) If fitness and quality are equal, provide Recycled-Content Paper Products  
1411 and Recycled-Content Printing and Writing Paper that consists of at least  
1412 30 percent, by fiber weight, postconsumer fiber instead of non-recycled  
1413 products whenever recycled Paper Products and Printing and Writing Paper

1414 are available at the same or lesser total cost than non-recycled items or at  
1415 a total cost of no more than \_\_\_% of the total cost for non-recycled items.

1416 Guidance: Jurisdictions that do not want to include any pricing preference for  
1417 Recycled-Content Paper should delete the highlighted text. Jurisdictions that want  
1418 to establish a pricing preference for purchase of Recycled-Content Paper shall  
1419 insert a percentage amount, and jurisdictions that want to require recycled content  
1420 paper products and printing and writing paper regardless of price, can delete the  
1421 phrase “whenever recycled paper products and printing and writing paper are  
1422 available at the same or lesser total cost than non-recycled items.

1423 (2) Provide Paper Products and Printing and Writing Paper that meet Federal  
1424 Trade Commission recyclability standard as defined in 16 Code of Federal  
1425 Regulations (CFR) Section 260.12.

1426 (3) Certify in writing, under penalty of perjury, the minimum percentage of  
1427 postconsumer material in the Paper Products and Printing and Writing  
1428 Paper offered or sold to the Jurisdiction. This certification requirement may  
1429 be waived if the percentage of postconsumer material in the Paper  
1430 Products, Printing and Writing Paper, or both can be verified by a product  
1431 label, catalog, invoice, or a manufacturer or vendor internet website.

1432 (4) Certify in writing, on invoices or receipts provided, which may be electronic,  
1433 that the Paper Products and Printing and Writing Paper offered or sold to  
1434 the Jurisdiction is eligible to be labeled with an unqualified recyclable label  
1435 as defined in 16 Code of Federal Regulations (CFR) Section 260.12 (2013).

1436 (5) Provide records to the Jurisdiction’s Recovered Organic Waste Product  
1437 procurement recordkeeping Designee, in accordance with the Jurisdiction’s  
1438 Recycled-Content Paper procurement policy(ies) of all Paper Products and  
1439 Printing and Writing Paper purchases within thirty (30) days of the purchase  
1440 (both recycled-content and non-recycled content, if any is purchased) made  
1441 by any division or department or employee of the Jurisdiction. Records shall  
1442 include a copy (electronic or paper) of the invoice or other documentation  
1443 of purchase, written certifications as required in Sections 13(b)(3) and  
1444 13(b)(4) of this ordinance for recycled-content purchases, purchaser name,  
1445 quantity purchased, date purchased, and recycled content (including  
1446 products that contain none), and if non-recycled content Paper Products or  
1447 Printing and Writing Papers are provided, include a description of why  
1448 Recycled-Content Paper Products or Printing and Writing Papers were not  
1449 provided.

1450 (c) All vendors providing compost to the jurisdiction shall:  
1451 Provide compost that meets the definition in Section 3(j) of this ordinance.

1452 (d) All vendors providing mulch to the jurisdiction shall:

1453 Provide SB 1383 eligible mulch that meets the definition in Section 3(eee)  
1454 of this ordinance.

1455 Guidance: Only compost and mulch that meets the definitions provided will be able to be  
1456 counted toward jurisdiction's annual recovered organic waste procurement target  
1457 provided by CalRecycle.

## 1458 SECTION 14. INSPECTIONS AND INVESTIGATIONS BY JURISDICTION

1459 Guidance: SB 1383 Regulations (14 CCR, Division 7, Chapter 12, Article 14) require  
1460 Jurisdictions to inspect regulated entities for compliance and to take Enforcement Action  
1461 against non-compliant entities including generators, Tier One and Tier Two Commercial  
1462 Edible Food Generators, Food Recovery Organizations, Food Recovery Services,  
1463 haulers, and Self-Haulers. This Section 14 provides example ordinance language to  
1464 provide the Jurisdiction the right to conduct Inspections and investigations. Section 15  
1465 addresses enforcement. This Model language presents a simple approach to establishing  
1466 the right to inspect or investigate. Jurisdictions have the option to expand on this to  
1467 include more specificity, such as who has the authority to inspect, what entities may be  
1468 inspected or investigated, and the protocols for such Inspections and investigations.

1469 (a) Jurisdiction representatives and/or its designated entity, including the Designee for  
1470 Edible Food Recovery are authorized to conduct Inspections and investigations,  
1471 at random or otherwise, of any collection container, collection vehicle loads, or  
1472 transfer, processing, or disposal facility for materials collected from generators, or  
1473 Source Separated materials to confirm compliance with this ordinance by Organic  
1474 Waste Generators, Commercial Businesses (including Multi-Family Residential  
1475 Dwellings), property owners, Tier One and Tier Two Commercial Edible Food  
1476 Generators, haulers, Self-Haulers, Food Recovery Services, and Food Recovery  
1477 Organizations, subject to applicable laws.

1478 This Section does not allow Jurisdiction to enter the interior of a private residential  
1479 property for Inspection.

1480 For the purposes of inspecting Commercial Business containers for compliance  
1481 with Section 5(b) of this ordinance, Jurisdiction may conduct container Inspections  
1482 for Prohibited Container Contaminants using Remote Monitoring, and Commercial  
1483 Businesses shall accommodate and cooperate with the Remote Monitoring  
1484 pursuant to Section 5(k) of this ordinance. (Optional)

1485 Guidance: Highlighted sentences in this section mentioning remote monitoring are  
1486 optional in the event that jurisdiction and its hauler want to consider using a remote  
1487 monitoring system to monitor for contamination. These highlighted sections can be  
1488 removed if jurisdiction (and hauler) does not anticipate using remote monitoring.

1489 (b) Regulated entity shall provide or arrange for access during all Inspections (with the  
1490 exception of residential property interiors) and shall cooperate with the

1491 Jurisdiction’s employee or its designated entity or Designee for Edible Food  
1492 Recovery during such Inspections and investigations. Such Inspections and  
1493 investigations may include confirmation of proper placement of materials in  
1494 containers, Edible Food Recovery activities, records, or any other requirement of  
1495 this ordinance described herein. Failure to provide or arrange for: (i) access to an  
1496 entity’s premises; (ii) installation and operation of Remote Monitoring equipment  
1497 (optional); or (ii) access to records for any Inspection or investigation is a violation  
1498 of this ordinance and may result in penalties described.

1499 (c) Any records obtained by a Jurisdiction or Designee for Edible Food Recovery  
1500 during its Inspections, Remote Monitoring, and other reviews shall be subject to  
1501 the requirements and applicable disclosure exemptions of the Public Records Act  
1502 as set forth in Government Code Section 6250 et seq.

1503 (d) Jurisdiction representatives, its designated entity, and/or Designee for Edible Food  
1504 Recovery are authorized to conduct any Inspections, Remote Monitoring, or other  
1505 investigations as reasonably necessary to further the goals of this ordinance,  
1506 subject to applicable laws.

1507 (e) Jurisdiction and Designee for Edible Food shall receive written complaints from  
1508 persons regarding an entity that may be potentially non-compliant with SB 1383  
1509 Regulations, including receipt of anonymous complaints.

1510 Guidance: Jurisdiction is required to have a method to accept anonymous  
1511 complaints and require that all complaints be made in writing with specified  
1512 information. SB 1383 Regulations (14 CCR Section 18995.3) provide more  
1513 guidance.

## 1514 SECTION 15. ENFORCEMENT

1515 Guidance: SB 1383 Regulations (14 CCR, Division 7, Chapter 12, Articles 14 and 16)  
1516 specify Jurisdiction’s requirements for enforcement and assessment of administrative civil  
1517 penalties, respectively. Jurisdictions will need to make sure that the enforcement  
1518 language in this section conforms with their own enforcement procedures and modify the  
1519 language to match current and desired procedures. Jurisdictions can provide  
1520 enforcement procedures and requirements stricter than those specified in the SB 1383  
1521 Regulations at its option.

1522 (a) Violation of any provision of this ordinance shall constitute grounds for issuance of  
1523 a Notice of Violation and assessment of a fine by a Jurisdiction Enforcement  
1524 Official, Designee for Edible Food Recovery, or representative. Enforcement  
1525 Actions under this ordinance are issuance of an administrative citation and  
1526 assessment of a fine. The Jurisdiction’s procedures on imposition of administrative  
1527 fines are hereby incorporated in their entirety, as modified from time to time, and  
1528 shall govern the imposition, enforcement, collection, and review of administrative



1529 citations issued to enforce this ordinance and any rule or regulation adopted  
1530 pursuant to this ordinance, except as otherwise indicated in this ordinance.

1531 (b) Other remedies allowed by law may be used, including civil action or prosecution  
1532 as misdemeanor or infraction. Jurisdiction or Designee for Edible Food Recovery  
1533 may pursue civil actions in the California courts to seek recovery of unpaid  
1534 administrative citations. Jurisdiction or Designee for Edible Food Recovery may  
1535 choose to delay court action until such time as a sufficiently large number of  
1536 violations, or cumulative size of violations exist such that court action is a  
1537 reasonable use of Jurisdiction or Designee for Edible Food Recovery staff and  
1538 resources.

1539 (c) Responsible Entity for Enforcement

1540 (1) Enforcement pursuant to this ordinance may be undertaken by the  
1541 Jurisdiction Enforcement Official, which may be the **city manager or their**  
1542 **designee, legal counsel, or combination thereof**, or Designee for Edible  
1543 Food Recovery.

1544 (A) Jurisdiction Enforcement Official(s) and Designee for Edible Food  
1545 Recovery (for Edible Food Recovery provisions) will interpret  
1546 ordinance; determine the applicability of waivers, if violation(s) have  
1547 occurred; implement Enforcement Actions; and, determine if  
1548 compliance standards are met.

1549 (B) Jurisdiction Enforcement Official(s) and Designee for Edible Food  
1550 Recovery (for Edible Food Recovery provisions) may issue Notices  
1551 of Violation(s).

1552 (d) Process for Enforcement

1553 (1) Jurisdiction Enforcement Officials or Designee for Edible Food Recovery  
1554 and/or their Designee will monitor compliance with the ordinance randomly  
1555 and through Compliance Reviews, Route Reviews, investigation of  
1556 complaints, and an Inspection program (that may include Remote  
1557 Monitoring). Section 14 establishes Jurisdiction's and Designee for Edible  
1558 Food Recovery's right to conduct Inspections and investigations.

1559 (2) Jurisdiction or Designee for Edible Food Recovery may issue an official  
1560 notification to notify regulated entities of its obligations under the ordinance.

1561 Guidance: SB 1383 regulations require jurisdictions, upon finding prohibited container  
1562 contaminants in a container (through annual random route reviews), to notify the  
1563 generator of the violation and provide information regarding the generator's requirement  
1564 to properly separate materials into the appropriate containers. The notice may be left on  
1565 the generator's container, gate, or door at the time the violation occurs, and/or sent later.  
1566 The regulations do not, however, require jurisdictions to impose administrative civil  
1567 penalties on generators for violation of prohibited container contaminants requirements.

1568 Jurisdiction should amend provision below to be consistent with its process for addressing  
1569 prohibited container contaminants. If jurisdictions are not planning, in conjunction with its  
1570 hauler to assess contamination penalties or contamination processing fees for additional  
1571 costs of processing Contaminated Containers, then it should delete the highlighted  
1572 section below. If jurisdictions choose to include these optional fees, this Section should  
1573 be modified to specify the conditions and procedure for issuance of the fees. For example,  
1574 a fee could be assessed per instance of contamination or could be assessed after certain  
1575 number of consecutive instances, such as 1, 2 or 3.

1576

1577 (3) For incidences of Prohibited Container Contaminants found in containers,  
1578 Jurisdiction will issue a Notice of Violation to any generator found to have  
1579 Prohibited Container Contaminants in a container. Such notice will be  
1580 provided via a cart tag or other communication immediately upon  
1581 identification of the Prohibited Container Contaminants or within 30 days  
1582 after determining that a violation has occurred. If the Jurisdiction observes  
1583 Prohibited Container Contaminants in a generator's containers on more  
1584 than two (2) consecutive occasion(s), the Jurisdiction may assess  
1585 contamination processing fees or contamination penalties on the generator.

1586 For the purposes of Edible Food Recovery, for incidences of Prohibited  
1587 Container Contaminants found in containers, the Jurisdiction or its  
1588 Designee for Edible Food Recovery will issue a Notice of Violation to any  
1589 Tier One or Tier Two Commercial Edible Food Generator found to have  
1590 Prohibited Container Contaminants, such as Edible Food, in a container, or  
1591 to any Food Recovery Organization or Food Recovery Service found to  
1592 have Prohibited Container Contaminants, such as Edible Food recovered  
1593 from a Tier One or Tier Two Edible Food Generator, in a container, which  
1594 has not been documented by a complaint of spoilage as required in this  
1595 Ordinance. Such notice will be provided by email communication  
1596 immediately upon identification of the Prohibited Container Contaminants  
1597 or within 3 days after determining that a violation has occurred. If the  
1598 Jurisdiction or its Designee for Edible Food Recovery observes Prohibited  
1599 Container Contaminants, such as Edible Food, in a Food Recovery  
1600 Organization's or Food Recovery Service's containers on more than two (2)  
1601 consecutive occasion(s), the Jurisdiction or its Designee for Edible Food  
1602 Recovery may assess contamination processing fees or contamination  
1603 penalties on the Edible Food Recovery Organization, or Food Recovery  
1604 Service.

1605

1606 (4) With the exception of violations of generator contamination of container  
1607 contents addressed under Section 15(d)(3), Jurisdiction or Designee for  
1608 Edible Food Recovery shall issue a Notice of Violation requiring compliance  
1609 within 60 days of issuance of the notice. For the purposes of Edible Food

1610 Recovery, the Designee for Edible Food Recovery may issue a Notice of  
1611 Violation requiring compliance within 7 days of issuance of the Notice.

1612 (5) Absent compliance by the respondent within the deadline set forth in the  
1613 Notice of Violation, Jurisdiction or Designee for Edible Food Recovery (for  
1614 the Edible Food Recovery provisions) shall commence an action to impose  
1615 penalties via an administrative citation and fine, pursuant to its  
1616 Administrative citation and fine procedures.

1617 For the purposes of Edible Food Recovery, the Designee for Edible Food  
1618 Recovery shall commence an action to impose penalties, via an  
1619 administrative citation and fine, pursuant to the Edible Food Recovery  
1620 Penalties provisions contained in this Ordinance.

1621 Notices shall be sent to “owner” at the official address of the owner  
1622 maintained by the tax collector for the Jurisdiction or if no such address is  
1623 available, to the owner at the address of the dwelling or Commercial  
1624 property or to the party responsible for paying for the collection services,  
1625 depending upon available information

1626 (e) Penalty Amounts for Types of Violations

1627 Guidance: SB 1383 Regulations (14 CCR Section 18997.2) require assessment of  
1628 penalties with minimum penalty levels consistent with the applicable requirements  
1629 prescribed in Government Code Sections 53069.4, 25132, and 36900.  
1630 Jurisdictions may choose to use the ranges of penalties included in the  
1631 Government Code Section and listed below, or may choose to amend the penalty  
1632 amounts shown below to establish a specific penalty level (rather than a range) for  
1633 each violation type. Jurisdictions that choose to pick a specific penalty amount  
1634 must select an amount that is somewhere in the range or higher than the amounts  
1635 shown below, but no lower than the lowest value for each range listed below, and  
1636 consistent with the ranges listed in Sections 53069.4, 25132, and 36900 of the  
1637 Government Code. Jurisdictions should indicate if these penalties are consistent  
1638 or different than administrative penalties in Jurisdiction’s code.

1639 The penalty levels for violations unrelated to the Edible Food Recovery  
1640 requirement are as follows:

1641 (1) For a first violation, the amount of the base penalty shall be \$50 to \$100 per  
1642 violation.

1643 (2) For a second violation, the amount of the base penalty shall be \$100 to  
1644 \$200 per violation.

1645 (3) For a third or subsequent violation, the amount of the base penalty shall be  
1646 \$250 to \$500 per violation.

1647 The penalty levels for Edible Food Recovery violations are as follows:

1648 (1) For a first violation, the amount of the base penalty shall be \$100 to \$200  
1649 per violation.

1650 (2) For a second violation, the amount of the base penalty shall be \$200-\$500  
1651 per violation.

1652 (3) For a third or subsequent violation, the amount of the base penalty shall be  
1653 \$500 to \$2000 per violation.

1654 (f) Compliance Deadline Extension Considerations

1655 The Jurisdiction or Designee for Edible Food Recovery (the County for edible food  
1656 generator and food recovery organization and services requirements) may extend  
1657 the compliance deadlines set forth in a Notice of Violation issued in accordance  
1658 with Section 15 if it finds that there are extenuating circumstances beyond the  
1659 control of the respondent that make compliance within the deadlines impracticable,  
1660 including the following:

1661 (1) Acts of God such as earthquakes, wildfires, flooding, and other  
1662 emergencies or natural disasters;

1663 (2) Delays in obtaining discretionary permits or other government agency  
1664 approvals; or,

1665 (3) Deficiencies in Organic Waste recycling infrastructure or Edible Food  
1666 Recovery capacity and the Jurisdiction is under a corrective action plan with  
1667 CalRecycle pursuant to 14 CCR Section 18996.2 due to those deficiencies.

1668 (g) Appeals Process

1669 Persons receiving an administrative citation containing a penalty for an  
1670 uncorrected violation may request a hearing to appeal the citation. A hearing will  
1671 be held only if it is requested within the time prescribed and consistent with  
1672 Jurisdiction's or Designee for Edible Food Recovery's procedures in the  
1673 Jurisdiction's or Designee for Edible Food Recovery's codes for appeals of  
1674 administrative citations. Evidence may be presented at the hearing. The  
1675 Jurisdiction or Designee for Edible Food Recovery will appoint a hearing officer  
1676 who shall conduct the hearing and issue a final written order.

1677 Guidance: Jurisdiction shall select an employee or Designee to act as hearing  
1678 officer who is different from their enforcement official.

1679 (h) Education Period for Non-Compliance

1680 Beginning January 1, 2022 and through December 31, 2023, Jurisdiction or  
1681 Designee for Edible Food Recovery (for edible food generator and food recovery  
1682 organization and service requirements) may conduct Inspections, Remote  
1683 Monitoring, Route Reviews or waste evaluations, and Compliance Reviews,

1684 depending upon the type of regulated entity, to determine compliance, and if  
1685 Jurisdiction **or Designee for Edible Food Recovery** determines that Organic Waste  
1686 Generator, Self-Hauler, hauler, Tier One Commercial Edible Food Generator,  
1687 Food Recovery Organization, Food Recovery Service, or other entity is not in  
1688 compliance, **it shall provide educational materials and/or, for the purposes of**  
1689 **Edible Food Recovery, training** to the entity describing its obligations under this  
1690 ordinance and a notice that compliance is required by January 1, 2022, and that  
1691 violations may be subject to administrative civil penalties starting on January 1,  
1692 2024.

1693 Guidance: Jurisdictions may initiate the education period prior to January 1, 2022,  
1694 but no later than that date pursuant to SB 1383 Regulations (14 CCR Section  
1695 18995.1(a)(4)).

1696 (i) Civil Penalties for Non-Compliance

1697 Beginning January 1, 2024, if the Jurisdiction **or Designee for Edible Food**  
1698 **Recovery** (Designee for Edible Food determination only for Tier 1 and Tier 2  
1699 Commercial Edible food generator and food recovery organization and service  
1700 requirements) determines that an Organic Waste Generator, Self-Hauler, hauler,  
1701 Tier One or Tier Two Commercial Edible Food Generator, Food Recovery  
1702 Organization, Food Recovery Service, or other entity is not in compliance with this  
1703 ordinance, it shall document the noncompliance or violation, issue a Notice of  
1704 Violation, and take Enforcement Action pursuant to Section 15, as needed.

1705 Guidance: 14 CCR Section 18995.4(a)(1) requires that Jurisdictions initiate  
1706 Enforcement Actions no later than January 1, 2024. Jurisdiction may consider  
1707 having penalties start earlier than January 1, 2024. If so, it shall amend the dates  
1708 in Sections 15(i) and 15(j) above to fit its commencement date for enforcement.

## 1709 **SECTION 16. EFFECTIVE DATE**

1710 This ordinance shall be effective commencing on January 1, 2022.

## Exhibit A

**Memorandum of Understanding  
Between the Jurisdictions of Belmont, Burlingame, East Palo Alto, Foster City,  
Hillsborough, Menlo Park, Redwood City, San Carlos, San Mateo, West Bay  
Sanitary District, and the County of San Mateo and  
The South Bayside Waste Management Authority  
Regarding Implementation of SB 1383 Regulations**

This Memorandum of Understanding (“MOU”) is made this \_\_\_\_ day of \_\_\_\_\_, 2021 (“Effective Date”) by and between the **COUNTY OF SAN MATEO**, a political subdivision of the State of California, the **CITIES OF BELMONT, BURLINGAME, EAST PALO ALTO, FOSTER CITY, HILLSBOROUGH, MENLO PARK, REDWOOD CITY, SAN CARLOS, SAN MATEO**, each a municipal corporation of the State of California, the **WEST BAY SANITARY DISTRICT**, a California independent district, (the County and Cities and West Bay Sanitary District are referred to individually herein as a “Jurisdiction”) and the **SOUTH BAYSIDE WASTE MANAGEMENT AUTHORITY**, a California joint powers authority (“Agency”) (collectively the “Parties”).

**RECITALS**

**WHEREAS**, the Agency is a joint powers authority established pursuant to the California Joint Exercise of Powers Act (Gov. Code section 6500 *et seq.*); and

**WHEREAS**, each of the Jurisdictions is a member of the Agency, and the Agency operates certain core programs on behalf of and for the benefit of the Jurisdictions, including but not limited to providing education regarding recycling, composting, and other methods of waste diversion to the Jurisdictions and the public, and conducting, preparing, and submitting all monitoring and reporting pursuant to the Integrated Waste Management Act (California Public Resources Code §§40000 *et seq.*); and

**WHEREAS**, the State of California passed SB 1383 (Chapter 395, Statutes of 1383), which required the California Department of Resources Recycling and Recovery (CalRecycle) to adopt regulations to reduce statewide disposal of organic waste by 50 percent from its 2014 baseline level by 2020 and 75 percent by 2025; and

**WHEREAS**, CalRecycle has finalized SB 1383 Regulations that among other things created new Chapter 12 (Short-lived Climate Pollutants) of Division 7 of Title 14 of the California Code of Regulations (“SB 1383 Regulations”); and

**WHEREAS**, the SB 1383 Regulations require local agencies or jurisdiction to implement Edible Food Recovery programs; to promote consistency within jurisdictions throughout San Mateo County and leverage economies of scale, the County has offered to lead the creation of a County-wide Edible Food Recovery Program on behalf of the unincorporated areas of the county and all the cities in the county and has developed a separate MOU to be entered into by the cities in conjunction with that program;

**WHEREAS**, in addition, the SB 1383 Regulations require local agencies or jurisdictions, among other things, to implement programs requiring organic waste generators and waste haulers to meet minimum standards for organic waste collection services, inspect waste containers for prohibited contamination of materials, provide education and outreach information to organic waste generators, report to CalRecycle on compliance with SB 1383 Regulations, and maintain records of compliance with SB 1383 Regulations; and

**WHEREAS**, Jurisdictions may designate a public or private entity to fulfill the requirements of Chapter 12: Short-lived Climate Pollutants, except that the Jurisdictions shall remain ultimately responsible for compliance; and

**WHEREAS**, the Parties are entering into this MOU to designate certain roles and responsibilities that the Agency shall assume on behalf of the Jurisdictions to implement the SB 1383 Regulations (excluding the Edible Food Recovery Program requirements undertaken by the County in the separate MOU) that will take effect on January 1, 2022 under the terms and conditions as set forth herein.

**NOW, THEREFORE**, in consideration of the foregoing, the Parties hereby agree as follows:

## **AGREEMENT**

1. **Term.** This MOU shall commence on the Effective Date and remain in full force and effect until terminated as set forth in Section 6 of this MOU.

2. **Definitions.**

(a) "Agency" means the South Bayside Waste Management Authority.

(b) "CalRecycle" or "Department" means the California State Department of Resources Recycling and Recovery.

(c) "City" means one of the cities or towns that is a member of the Agency.

(d) "County" means the County of San Mateo.

(e) "Edible Food" means food intended for human consumption.

(f) "Generator" means a person or entity that is responsible for the initial creation of organic waste.

(g) "Hauler" means a person or entity who collects material from a Generator and delivers it to a reporting entity, end user, or a destination outside of the

state. "Hauler" includes public contract haulers, private contract haulers, food waste self-haulers, and self-haulers. A person who transports material from a reporting entity to another person is a transporter, not a hauler.

(h) "Implementation Record" means all records, physical or electronic, that must be stored in one central location and are required by Chapter 12: Short-lived Climate Pollutants.

(i) "Jurisdiction" means a City, or West Bay Sanitary District, or the County, each of which provides solid waste collection services within their jurisdictional boundaries.

(j) "Local Enforcement Agency" or "LEA" means the San Mateo County Department of Health Services, Solid Waste Local Enforcement Agency.

(k) "Organics," or "Organic Waste" are materials that originate from living organisms and their metabolic waste products, including but not limited to, food, green material, landscape and pruning waste, organic textiles, paper products, printing and writing paper, vegetables, grain, meat, bones, paper towels, leaves, and wood.

(l) "Route review" means a visual inspection of containers along a hauler route for the purpose of determining container contamination, and may include mechanical inspection methods such as the use of cameras.

(m) "SB 1383 Regulations," "Regulations," or "Chapter" means, for the purposes of the MOU, Chapter 12 (Short-lived Climate Pollutants) of Division 7 of Title 14 of the California Code of Regulations. Regulatory references to specific sections listed in the MOU shall be to the SB 1383 Regulations, unless specifically noted otherwise.

(n) "Waste evaluation" means collecting samples from garbage, recycling, and organics from different areas in the jurisdiction so that the samples are representative of the jurisdiction's waste stream.

### 3. **Responsibilities of the Agency.**

(a) **General.** The Agency shall conduct the services described in this Section for the Jurisdictions. The Jurisdictions are delegating certain responsibilities related to Chapter 12 to the Agency as described in this Section. The Agency shall conduct the services described in this Section for the Jurisdictions in a manner in which each Jurisdictions receives services in an equitable manner.

(b) **Education and outreach.** The Agency shall provide educational materials and community outreach to organic waste Generators in English, Spanish, and Chinese that explain and provide information on the requirements of the SB 1383 Regulations, as more specifically described below, and will be consistent with the scope of work listed in the three-year Public Education and Recycling Technical Assistance Plan.



(i) Prior to February 1, 2022, the Agency will make available to Generators, through print and/or electronic media, information regarding §§ 18984.9, 18984.10, 18985.1, 18985.2, 18988.3, 18991.3, 18991.4, and 18991.5 of the Regulations. This information shall be maintained and updated at least annually.

(ii) The Agency shall send letters to residential and commercial Generators who have not subscribed to Recyclable Materials or Organics Collection Services and those who are found to have prohibited container contaminants. The letters shall provide information and resources to comply with the Regulations related to the collection and recovery of Recyclable Materials and Organic Waste. The Agency shall work with each individual Jurisdiction and the franchise Hauler to tailor the letters to the Jurisdiction's needs.

(c) **Procurement.** The Agency shall annually notify each Jurisdiction of its Organic Waste product procurement target, as required and determined by CalRecycle. Before CalRecycle releases the official procurement targets for each Jurisdiction on January 1, 2022 and every five years thereafter, the Agency shall assist the Jurisdictions in calculating estimates of the procurement targets. (§18993.1)

(d) **Reporting and recordkeeping.**

(i) The Agency shall submit reports for Organics processing capacity and Edible Food recovery planning requirements according to the County within 120 days of the County's request as required by Article 11 of Chapter 12 (§ 18992.3).

(ii) The Agency will be the primary recordkeeper for all the information and documents required in the Implementation Record. (§ 18995.2) Each Jurisdiction will be given access to their own set of records through a cloud-based software. Agency staff will upload documents within the 60-day timeframe as required in the Chapter, provided that the information is made available to the Agency by the necessary parties in a timeframe that allows for such uploading.

(iii) Upon request by a CalRecycle representative or the public through a Public Records Act request, either the Agency or the Jurisdiction will provide access to the Implementation Record. Agency and Jurisdiction shall notify the other of the request and coordinate a response.

(iv) The Agency shall submit the Initial Jurisdiction Compliance Report and Jurisdiction Annual Reports to CalRecycle as detailed in §§ 18994.1, 18994.2.

(e) **Organic waste processing capacity and diversion planning.** The Agency shall work with the County of San Mateo to estimate existing Organics processing and Edible Food recovery capacities available in the service area (§§ 18992.1, 18992.2). If it is found that either are lacking, the Agency shall assist the Jurisdictions in creating an implementation plan to expand capacity.

(f) **Model Tools.** The Agency shall revise three Model Tools, which were created by CalRecycle and HF&H, to better fit the Jurisdictions' needs. The Agency shall assist the Jurisdictions in tailoring the language further if necessary, although it will ultimately be the Jurisdictions' responsibility to use or adopt them. The Model Tools are:

- (i) Model Franchise Agreement Amendment and Exhibits with Recology;
- (ii) Model Mandatory Organic Waste Disposal Reduction Ordinance; and
- (iii) Model Procurement Policy

(g) **Complaints and violations.** Agency shall forward to the Jurisdictions all complaints alleging non-compliance with the Regulations for investigation. The Agency shall also provide to the Jurisdictions the names and associated contact information of Generators who repeatedly refuse to comply with the Regulations. The Agency shall notify the Jurisdictions of these complaints and violations within 10 business days of receipt of such complaints by the Agency.

(h) **Waivers.**

(i) Since the authority to issue waivers cannot be delegated to a private entity, the Agency shall approve or deny each waiver request, with support from Jurisdiction as needed, except as otherwise provided herein. Waivers may be granted by the Agency for de minimis volumes and physical space limitations. (§ 18984.11). Eligibility for waivers will be reviewed by the Agency every 5 years after written verification of eligibility is provided by the Commercial Business or property owner. The Agency will provide Jurisdictions with a list of Generators who are approved and denied a waiver.

(1) The Agency will create a standardized waiver request form for Jurisdictions and Haulers to distribute or make available to Generators. This form will be a printable document maintained on the Agency's website.

(2) De Minimis Waivers: The Agency may waive a Commercial Business' obligation (including Multi-Family Residential Dwellings) to comply with some or all of the Recyclable Materials and Organic Waste requirements of each Jurisdiction's ordinance if the Commercial Business provides documentation that the business' total Solid Waste, Recyclable Materials, and Organic Waste collection service is two cubic yards or more per week and Organic Waste subject to collection in the Organic Waste Container comprises less than 20 gallons per week or the Paper Products and Printing and Writing Paper subject to collection in the Recyclable Materials Container; or if the total Solid Waste, Recyclable Materials, and Organic Waste collection service is less than two cubic yards per week and Organic Waste subject to collection in the Green Container comprises less than 10 gallons per week or

the Paper Products and Printing and Writing Paper subject to collection in the Recyclable Materials Container.

(3) **Physical Space Waivers:** The Agency may waive a Commercial Business' or property owner's obligations (including Multi-Family Residential Dwellings) to comply with some or all of the recyclable materials and/or Organic Waste collection service requirements if the Agency has evidence from its own staff, a hauler, licensed architect, or licensed engineer demonstrating that the premises lacks adequate space for the collection containers required for compliance with the Recyclable Materials and Organic Waste collection requirements specified in each Jurisdictions' ordinance or municipal code.

(4) Since weekly pickup of solid waste is required by the LEA, Collection Frequency Waivers will not be granted to Generators in any of the Jurisdictions.

(i) **Emergency Circumstances – Waivers for Jurisdiction**

(i) The Agency will notify CalRecycle and apply for a waiver to landfill organics if any of the Jurisdictions experience a natural disaster, uses a recyclable materials or organic waste processing facility that has a temporary operational failure, or unforeseen operational restrictions have been imposed upon it by a regulatory agency. (§18984.13)

4. **Responsibilities of the Jurisdictions.**

(a) The Jurisdictions shall assume responsibility for all other requirements specified for Jurisdictions in the Regulations not expressly stated to be covered by the Agency in this MOU.

(b) **Sharing of information.** Within thirty (30) days of request by the Agency, or as soon as such information is available to the Jurisdictions, the Jurisdictions shall share with the Agency all data, documents, contact information for Generators within the Jurisdiction, or any other information necessary for the Agency to carry out the responsibilities listed in this MOU.

(c) **Staff and funding.** In order for the Agency to carry out its responsibilities in connection with the administration and implementation of the SB 1383 Regulations as specified in this MOU, costs shall be jointly shared by participating Jurisdictions through the garbage tipping fee rate. Budget changes related to this MOU will be integrated into the Agency's regular budget process, as approved by the Board of Directors.

5. **Indemnification/Hold Harmless.** Agency shall indemnify, defend, and hold harmless the Jurisdictions, their legislative bodies, officials, consultants, agents, and employees from and against any and all loss, damages, liability, claims, suits, costs and expenses, including reasonable attorney's fees, arising from Agency's performance of this MOU, with the exception of matters that are based upon the negligent or

intentional acts or omissions of the Jurisdictions, their legislative bodies, officials, consultants, agents and employees.

6. **Withdrawal of Jurisdictions; Termination by Agency.** Any Jurisdiction may withdraw as a Party to this MOU upon giving one hundred and eighty (180) calendar days' prior written notice to the other Parties. Further, the Agency may terminate this MOU upon giving three hundred and sixty-five (365) days' prior written notice to the Jurisdictions.

(a) Upon termination of this MOU, the Agency shall have no further obligations to carry out the Agency Responsibilities as described in this MOU. The Agency will provide the Jurisdiction all records related to the Implementation Record (§ 18995.2). If a Jurisdiction withdraws from this MOU, the Jurisdiction will be required to pay the Agency, for its full portion of expense and consultant contract costs, to conduct the services described in Section 3 under this MOU including costs generated through the end of the Agency's fiscal year of the Jurisdiction withdrawal.

(b) The costs of services under the MOU will be reapportioned to the remaining Jurisdictions. Reapportioned costs will be brought to the SBWMA Board of Directors through the regular budgeting process.

7. **Notice.** During the Term of this MOU, all notices shall be made in writing and either served personally, sent by first class mail, or sent by email provided confirmation of delivery is obtained at the time of email transmission, addressed as follows:

To: Agency  
South Bayside Waste Management Authority  
Attention: Executive Director  
610 Elm Street, Suite 202  
San Carlos, CA 94070  
Telephone Number:  
Email:

To City of Belmont:  
City of Belmont  
Attention: City Manager  
\_\_\_\_\_  
Belmont, CA \_\_\_\_\_  
Telephone Number:  
Email:

To City of Burlingame:  
City of Burlingame  
Attention: City Manager  
\_\_\_\_\_

Burlingame, CA \_\_\_\_\_  
Telephone Number:  
Email:

To City of East Palo Alto:

City of East Palo Alto  
Attention: City Manager

\_\_\_\_\_  
East Palo Alto, CA \_\_\_\_\_  
Telephone Number:  
Email:

To City of Foster City:

City of Foster City  
Attention: City Manager

\_\_\_\_\_  
Foster City, CA \_\_\_\_\_  
Telephone Number:  
Email:

To Town of Hillsborough:

Town of Hillsborough  
Attention: City Manager

\_\_\_\_\_  
Hillsborough, CA \_\_\_\_\_  
Telephone Number:  
Email:

To City of Menlo Park:

City of Menlo Park  
Attention: City Manager

\_\_\_\_\_  
Menlo Park, CA \_\_\_\_\_  
Telephone Number:  
Email:

To City of Redwood City:

City of Redwood City  
Attention: City Manager

\_\_\_\_\_  
Redwood City, CA \_\_\_\_\_  
Telephone Number:  
Email:

To City of San Carlos: City of San Carlos  
Attention: City Manager  
\_\_\_\_\_  
San Carlos, CA \_\_\_\_\_  
Telephone Number:  
Email:

To City of San Mateo: City of San Mateo  
Attention: City Manager  
\_\_\_\_\_  
San Mateo, CA \_\_\_\_\_  
Telephone Number:  
Email:

To County of San Mateo: County of San Mateo  
Attention: County Manager  
\_\_\_\_\_  
Redwood City, CA \_\_\_\_\_  
Telephone Number:  
Email:

To West Bay San. District: West Bay Sanitary District  
Attention: District Manager  
\_\_\_\_\_  
Menlo Park, CA \_\_\_\_\_  
Telephone Number:  
Email:

Any Party may change the address to which notice is to be given by providing the other Parties with written notice of such change at least fifteen (15) calendar days prior to the effective date of the change.

Service of notices shall be deemed complete on the date of receipt if personally served or if served using email provided confirmation of delivery is obtained at the time of email transmission. Service of notices sent by first class mail shall be deemed complete on the fifth (5<sup>th</sup>) day following deposit in the United States mail.

**8. Governing Law and Venue.** This MOU shall be deemed to be executed within the State of California and construed in accordance with and governed by laws of the State of California. Venue in any proceeding or action among the participating Jurisdictions arising out of this MOU shall be in San Mateo County, California.

9. **Amendment.** This MOU and the exhibits hereto may only be amended in writing signed by all Parties, and any purported amendment shall be of no force or effect. This MOU may be amended to both extend the term and conditions, as well as to add tasks. Agency shall not begin new tasks without express written permission of the Cities.

10. **Entire Agreement.** This MOU and its exhibits constitute the entire agreement between the Jurisdictions and the Agency and supersedes all prior negotiations, representations, or agreements, whether written or oral.

[Signatures on following page]

**SIGNATURE PAGE FOR MEMORANDUM OF UNDERSTANDING**  
**Between the Jurisdictions of Belmont, Burlingame, East Palo Alto, Foster City,**  
**Hillsborough, Menlo Park, Redwood City, San Carlos, San Mateo, West Bay**  
**Sanitary District, and the County of San Mateo and**  
**The South Bayside Waste Management Authority**  
**Regarding Implementation of SB 1383**

**IN WITNESS WHEREOF**, the Parties hereto have executed this agreement in duplicate on the day and year first above written.

**CITY OF BELMONT**, A Municipal Corporation of the State of California

By: \_\_\_\_\_

City Manager

APPROVED AS TO FORM:

\_\_\_\_\_

City Attorney

**CITY OF BURLINGAME**, A Municipal Corporation of the State of California

By: \_\_\_\_\_

City Manager

APPROVED AS TO FORM:

\_\_\_\_\_

City Attorney

**CITY OF EAST PALO ALTO**, A Municipal Corporation of the State of California

By: \_\_\_\_\_

City Manager



APPROVED AS TO FORM:

---

City Attorney

**CITY OF FOSTER CITY**, A Municipal Corporation of the State of California

By: \_\_\_\_\_

City Manager

APPROVED AS TO FORM:

---

City Attorney

**TOWN OF HILLSBOROUGH**, A Municipal Corporation of the State of California

By: \_\_\_\_\_

City Manager

APPROVED AS TO FORM:

---

City Attorney

**CITY OF MENLO PARK**, A Municipal Corporation of the State of California

By: \_\_\_\_\_

City Manager

APPROVED AS TO FORM:

---

City Attorney

**CITY OF REDWOOD CITY**, A Municipal Corporation of the State of California

By: \_\_\_\_\_

City Manager

APPROVED AS TO FORM:

---

City Attorney

**CITY OF SAN CARLOS**, A Municipal Corporation of the State of California

By: \_\_\_\_\_

City Manager

APPROVED AS TO FORM:

---

City Attorney

**CITY OF SAN MATEO**, A Municipal Corporation of the State of California

By: \_\_\_\_\_

City Manager

APPROVED AS TO FORM:

---

City Attorney

**COUNTY OF SAN MATEO**, A Municipal Corporation of the State of California

By: \_\_\_\_\_

County Administrator

APPROVED AS TO FORM:

\_\_\_\_\_

County Counsel

**WEST BAY SANITARY DISTRICT**, An Independent District of the State of California

By: \_\_\_\_\_

District Manager

\_\_\_\_\_

APPROVED AS TO FORM:

\_\_\_\_\_

District Counsel

**SOUTH BAYSIDE WASTE MANAGEMENT AUTHORITY**, A California Joint Powers Authority

By: \_\_\_\_\_

Executive Director

APPROVED AS TO FORM:

---

Agency Counsel



**MEMORANDUM OF UNDERSTANDING  
BETWEEN JURISDICTION OF [NAME] AND COUNTY OF SAN MATEO FOR THE  
ESTABLISHMENT OF AN EDIBLE FOOD RECOVERY PROGRAM CONSISTENT  
WITH CALIFORNIA CODE OF REGULATIONS, TITLE 14, DIVISION 7, CHAPTER  
12 SHORT-LIVED CLIMATE POLLUTANTS**

THIS MEMORANDUM OF UNDERSTANDING (MOU), entered into this 1<sup>st</sup> day of December 2021, by and between the County of San Mateo, hereinafter called "the County" and the "Jurisdiction", hereinafter called "the Jurisdiction";

**W I T N E S S E T H:**

WHEREAS, the County's Board of Supervisors has enacted a Mandatory Organic Waste Disposal Reduction Ordinance as required by the California Code of Regulations, Title 14, Division 7, Chapter 12 Short-Lived Climate Pollutants; and

WHEREAS, to promote consistency within jurisdictions throughout San Mateo County and leverage economies of scale, the County has offered to lead the creation of a County-wide Edible Food Recovery Program on behalf of the unincorporated areas of the county and all the jurisdictions in the county; and

WHEREAS, the [jurisdiction's xx Council] adopted this Memorandum of Understanding on [date] and authorizes the County to operate an Edible Food Recovery Program on behalf of and within the Jurisdiction.

NOW, THEREFORE, IT IS HEREBY AGREED BY THE PARTIES HERETO AS FOLLOWS:

**1. Tasks to be Completed by the Jurisdiction**

- A. The County will create and coordinate the Edible Food Recovery program on behalf of the Jurisdiction, if the Jurisdiction performs each of the following actions:
- a) adopts and makes part of its municipal code an enforceable ordinance establishing an Edible Food Recovery program as required under the California Code of Regulations, Title 14, Division 7, Chapter 12 Short-Lived Climate Pollutants, including the specific provisions provided to the Jurisdiction by the County of San Mateo for edible food recovery definitions, requirements for Tier One and Tier Two Edible Food Generators, and requirements for Food Recovery Organizations and Food Recovery Services; and
  - b) enters into this Memorandum of Understanding; and
  - c) provides the County with a list and schedule of "large events" as defined by the California Code of Regulations, Title 14, Division 7, Chapter 12 Short-Lived Climate Pollutants occurring in the Jurisdiction; and

- d) after consultation with the County, is responsible for coordinating the required edible food recovery regulations for those “large events” occurring in the Jurisdiction; and
- e) authorizes, by ordinance, the County to enforce California Code of Regulations, Title 14, Division 7, Chapter 12 Short-Lived Climate Pollutants in Section (a) above, and to incorporate such authorization to include, without limitation, the authority to inspect, investigate, hold hearings, issue citations, and/or assess administrative fines on behalf of the Jurisdiction as its Designee for Edible Food Recovery; and
- f) shall develop a method to accept written complaints, including anonymous complaints, regarding an entity that may be potentially non-compliant with the Edible Food Recovery requirements as required under the California Code of Regulations, Title 14, Division 7, Chapter 12 Short-Lived Climate Pollutants, and direct all such complaints to the County; and
- g) acknowledges, by ordinance, that, notwithstanding this Memorandum of Understanding, the Jurisdiction is, as stated in California Code of Regulations, Title 14, Division 7, Chapter 12 Short-Lived Climate Pollutants, ultimately responsible for compliance with the said Code.

**Note: Some County of San Mateo Jurisdictions are Member Agencies of the South Bayside Waste Management Authority (SBWMA), a joint powers agency located within San Mateo County that provides solid waste and recyclables processing services for its Members; nothing in this MOU precludes the SBWMA from assisting its Member Agencies with the Tasks described in this MOU.**

## **2. Services to be Performed by the County**

- A. The County shall create and coordinate an Edible Food Recovery Program compliant with California Code of Regulations, Title 14, Division 7, Chapter 12 Short-Lived Climate Pollutants on behalf of the Jurisdiction so long as this Memorandum of Understanding is in effect in its entirety.
- B. The County shall provide such services and activities for the Jurisdiction as described in Exhibit A, attached hereto and incorporated by reference herein.
- C. The County shall offer only to provide services relating directly to the California Code of Regulations, Title 14, Division 7, Chapter 12 Short-Lived Climate Pollutants Edible Food Recovery regulations with the exception of a yearly analysis to be conducted by the County to estimate the amount of Green House Gas (GHG) emissions reduction to be attributed to edible food recovery activities in the Jurisdiction for use in their climate action plans.
- D. The County shall provide the Jurisdiction with the information and data necessary for the Jurisdiction to make their required reports to CalRecycle.

- E. The County will not be obligated to provide services if modifications are made to the ordinance by the Jurisdiction, which omits existing provisions and/or reduces the impact of the ordinance in any way.

### **3. Consideration**

The benefit of this MOU to the Jurisdiction is that it alleviates the need for staff, cost analysis, capacity assessment, expenditures for infrastructure, labor, administration, and record keeping for the edible food recovery activities in their jurisdiction.

The benefit of this MOU to both the County and the Jurisdiction is that this approach will create one uniform, standardized, and coordinated effort throughout the incorporated and unincorporated areas of San Mateo County.

### **4. Relationship of Parties**

It is expressly understood that this is an agreement between two independent entities, the County and the Jurisdiction, and that no individual agency, employee, partnership, joint venture, or other relationship is established by this MOU. The intent by both the County and the Jurisdiction is to create an independent collaborative relationship.

### **5. Hold Harmless**

- A. Except as provided in subsection b. below, the [Jurisdiction] shall indemnify and save harmless the County and its officers, agents, employees, and servants from all claims, suits, or actions of every name, kind, and description resulting from this Memorandum of Understanding, brought for, or on account of, any of the following:
  - a) Injuries to or death of any person, including the [Jurisdiction] or its employees/officers/agents;
  - b) Damage to any property of any kind whatsoever and to whomsoever belonging; or
  - c) Any other loss or cost, including but not limited to that caused by the concurrent active or passive negligence of the County and/or its officers, agents, employees, or servants. However, the [Jurisdiction]'s duty to indemnify and save harmless under this Section shall not apply to injuries or damage for which the County has been found in a court of competent jurisdiction to be solely liable by reason of its own negligence or willful misconduct.

The duty of the [Jurisdiction] to indemnify and save harmless as set forth by this Section shall include the duty to defend as set forth in Section 2778 of the California Civil Code.

- B. With respect to coordinating, implementing, and/or enforcing the required edible food recovery regulations for those "Large Events" (as defined by the California Code of Regulations, Title 14, Division 7, Chapter 12) occurring in the [Jurisdiction] pursuant to section 1.A.d. above,



- a) The County shall indemnify, defend, and hold harmless the [Jurisdiction] and its officers, agents, employees, and servants against all damages, claims, liabilities, losses, and other expenses, including without limitation attorneys' fees and related costs, whether or not a lawsuit or other proceeding is filed, to the extent that they arise out of the negligence or willful misconduct of County staff arising out of coordinating, implementing, and/or enforcing the required edible food recovery regulations for those Large Events occurring in the [Jurisdiction].
  - b) The [Jurisdiction] shall indemnify, defend, and hold harmless the County and its officers, agents, employees, and servants against all damages, claims, liabilities, losses, and other expenses, including without limitation attorneys' fees and related costs, whether or not a lawsuit or other proceeding is filed, to the extent they arise out of the negligence or willful misconduct of [Jurisdiction] staff arising out of coordinating, implementing, and/or enforcing the required edible food recovery regulations for those Large Events occurring in the [Jurisdiction].
- C. A party seeking indemnity and defense under this section shall provide the indemnifying and defending party with prompt notice of any claim and give control of its defense and settlement to the indemnifying and defending party. The party seeking indemnity and defense shall also cooperate in all reasonable respects with the indemnifying and defending party, its insurance company, and its legal counsel in its defense of such claim. The obligation to defend and indemnify pursuant to this section shall not cover any claim in which there is a failure to give the indemnifying and defending party prompt notice, but only to the extent that such lack of notice prejudices the defense of the claim. The indemnifying and defending party may not settle any potential suit hereunder without the other party's prior written approval, which will not to be unreasonably withheld, conditioned, or delayed. If a party who owes indemnity and defense under this section fails to promptly indemnify and defend a covered claim, the other party shall have the right to defend itself, and in such case, the party owning indemnity and defense shall promptly reimburse the other party for all of its associated costs and expenses.
- D. The obligations imposed by this section shall survive termination or expiration of the Memorandum of Understanding.

## **6. Amendment of MOU and Merger Clause**

This MOU, including the Exhibit attached hereto and incorporated herein by reference, constitutes the sole MOU of the parties hereto and correctly states the rights, duties, and obligations of each party as of this document's date. In the event that any term, condition, provision, requirement or specification set forth in this body of the MOU conflicts with or is inconsistent with any term, condition, provision, requirement, or specification in any exhibit and/or attachment to this MOU, the provisions of this body of the MOU shall prevail. Any prior MOU, promises, negotiations, or representations between the parties not expressly stated in this document are not binding. All subsequent modifications shall be in writing and will become effective when signed by both parties.

**7. Records**

The County shall maintain and preserve all records relating to this MOU in its possession and those of any third-party performing work related to this MOU for a period of five (5) years from the termination of this MOU.

**8. Assignability**

The County shall have the right to assign this MOU or any portion thereof to a third party or subcontract with a third party to perform any act required under this MOU without the prior written consent of the Jurisdiction.

**9. Notices**

Any written notice, request, demand, or other communication required or permitted hereunder shall be deemed to be properly given when deposited with the United States Postal Service, postage prepaid, or when transmitted by email communication, addressed:

In the case of the County, to:

Carolyn Bloede, Director  
County of San Mateo Office of Sustainability  
455 County Center, 4th Floor  
Redwood City, CA 94065  
Email: cbloede@smcgov.org

In the case of the Jurisdiction, to:

City Manager  
City of XXX  
XXX, CA 94XXX  
Email: XXX

**10. Controlling Law and Venue**

The validity of this MOU, the interpretation of its terms and conditions, and the performance of the parties hereto shall be governed by the laws of the State of California. Any action brought to enforce this action must be brought in the Superior Court of California in and for the County of San Mateo.

**11. Term and Termination**

Subject to compliance with the terms and conditions of the MOU, the term of this MOU shall commence on January 1, 2022 and shall automatically be renewed from year to year on the same terms and conditions. This MOU may be terminated without cause by the Jurisdiction or the County’s Director of Office of Sustainability or the Director’s designee at any time upon thirty (30) days written notice to the other party.

**12. Authority**

The parties warrant that the signatories to the MOU have the authority to bind their respective entities.

IN WITNESS WHEREOF, the parties hereto, by their duly authorized representatives, have affixed their hands.

**COUNTY OF SAN MATEO**

**CITY OF [Name]**

By: \_\_\_\_\_  
Carolyn Bloede  
Director, Office of Sustainability

By: \_\_\_\_\_  
[Name]  
[Title], [Department]

Date: \_\_\_\_\_

Date: \_\_\_\_\_

## **EXHIBIT A - SCOPE OF ACTIVITIES**

The activity listed below relating to the County of San Mateo's Edible Food Recovery Program will be conducted by the County and the Jurisdiction.

### **I. Establishment**

1. The County will develop and coordinate a standardized and uniform San Mateo County-wide Edible Food Recovery Program consistent with and compliant to California Code of Regulations, Title 14, Division 7, Chapter 12 Short-Lived Climate Pollutants. The program will operate within the Jurisdiction's boundaries and replace the need for the Jurisdiction to create such a program on their own. This program will operate in the unincorporated areas of the county as well as all jurisdictions in the county agreeing to similar MOUs.

### **II. Enforcement**

1. The County will conduct enforcement of the ordinance within the Jurisdiction using a complaint-based system consistent with the California Code of Regulations, Title 14, Division 7, Chapter 12 Short-Lived Climate Pollutants. The County will respond to complaints, investigate, and resolve reported issue(s).
2. The County will follow enforcement provisions detailed in the ordinance and described in the California Code of Regulations, Title 14, Division 7, Chapter 12 Short-Lived Climate Pollutants.
3. The County will keep detailed records of enforcement in the Jurisdiction for a minimum of five (5) years.
4. The County will provide the necessary records to the Jurisdiction for the Jurisdiction's required reporting about Edible Food Recovery work to CalRecycle.
5. The County will notify the Jurisdiction promptly about any related issues that arise that require the Jurisdiction's assistance or to request the Jurisdiction lead in resolving the issue(s) related to noncompliance.
6. The Jurisdiction will work with the County on any related issues requiring jurisdictional assistance or lead in resolving the issue(s) related to complaints and/or noncompliance by any Tier 1 and Tier 2 Edible Food Generator or Food Recovery Organization and Service as defined in the California Code of Regulations, Title 14, Division 7, Chapter 12 Short-Lived Climate Pollutants and operating within the Jurisdiction's boundaries.

# SB 1383

Reducing Short-Lived  
Climate Pollutants in  
California

An Overview of SB 1383's  
Organic Waste Reduction  
Requirements



A Public Agency

# SB 1383 Implementation

# CLIMATE CHANGE NEGATIVELY IMPACTS CALIFORNIA

Landfilled Organic Waste Emits  
**Methane Gas—**  
**A Super Pollutant**  
More Powerful than CO<sub>2</sub>

Methane Gas Contributes to  
Climate Change in California



**CALIFORNIA**  
is already experiencing  
the impacts of  
**CLIMATE CHANGE**

IN 2015 THE DROUGHT COST THE AGRICULTURE INDUSTRY IN THE CENTRAL VALLEY AN ESTIMATED \$2.7 BILLION & 20,000 JOBS

# SB 1383 Requirements

2020

50 PERCENT REDUCTION IN LANDFILLED ORGANIC WASTE  
(11.5 Million Tons Allowed Organic Waste Disposal)

2022

REGULATIONS TAKE EFFECT

2025

75 PERCENT REDUCTION IN LANDFILLED ORGANIC WASTE  
(5.7 Million Tons Allowed Organic Waste Disposal)

2025

20 PERCENT INCREASE IN RECOVERY OF CURRENTLY DISPOSED EDIBLE  
FOOD

# Jurisdiction Responsibilities

Provide Organics Collection Services to All Residents and Businesses



Conduct Education and Outreach to Community



Secure Access to Recycling and Edible Food Recovery Capacity



Establish Edible Food Recovery Program



Procure Recyclable and Recovered Organic Products



Monitor Compliance and Conduct Enforcement





# Responsibilities

## Jurisdictions Ultimately Responsible for Compliance

- Jurisdiction may delegate to public or private entity(ies)
- Exception that the authority to impose civil penalties can only be delegated to public agency

## Delegation

- RethinkWaste
- SMC Office of Sustainability
- Recology/South Bay Recycling
- Other contractors, jurisdictions

## Compliance Strategy

- RethinkWaste leads compliance for majority of requirements
- City leads compliance for ordinance adoption, C&D and WELO, enforcement and procurement
- SMC Office of Sustainability lead on food recovery program capacity

# Collection and Processing Approach

## Standard Compliance Approach

- 3-container system provided to ALL customers
- Limited waivers (space, de-minimis)

# RethinkWaste Service Area Compliance Needs



## Ordinances & Policies

Mandatory organics, food recovery, enforcement, and C&D ordinances are needed for entire service area. WELO policies required.



## Enforcement

Enforcement program to be implemented by City



## Product Procurement

Extensive compost, mulch, renewable fuel procurement requirements need to be met; recycled-content paper procurement



## Collection & Processing

Programs established through franchise but need large expansion for MFD/commercial organics compliance.



## Food Recovery

Food recovery programs will be led by SMC Office of Sustainability.



## Other

Memorandum of Understanding with RethinkWaste, outreach & education, recordkeeping, and reporting.

# Model SB 1383 Enforcement Ordinance



## RethinkWaste

- Develop model ordinance for jurisdictions to customize and adopt
- Provide technical assistance

## City

- Adopt/amend ordinances and policies
  - Mandatory ordinance with enforcement provisions
  - CALGreen-compliant C&D ordinance
  - WELO policy
  - Organics product procurement policy

# SB 1383 Enforcement



## RethinkWaste

- Conduct education and outreach
- Identify and educate non-compliant entities
- Report non-compliant entities to jurisdictions

## City

- Adopt enforcement ordinance
- Issue Notice Of Violations and assess penalties for non-compliant entities (Jan. 1, 2024)
- Hire more staff, if need for enforcement

# Procurement



## RethinkWaste

- Research options with SMC Office of Sustainability
- Coordinate compost and mulch distribution with member agencies, if materials are part of the compliance approach

## City

- Coordinate with SMC Office of Sustainability
- Support implementation of selected procurement program, which may involve use, sale, or donation of compost/mulch and/or support use of electricity or renewable natural gas
- Purchase recycled-content paper to meet SB 1383 specs
- Maintain records for above programs

10

# Recology Services



## RethinkWaste

- Work with Recology to provide SB 1383 compliant collection services
- Negotiate changes to collection and processing agreements
- Negotiate cost structure for new services
- Provide waivers to eligible generators

## City

- Review Amendment 2 of Franchise Agreement (Fall 2021)

# Food Recovery Program



## RethinkWaste

- Support the SMC Office of Sustainability with food recovery program outreach and education

## City

- Review MOU agreement with SMC Office of Sustainability



# Other



## RethinkWaste

- Hire additional staff and/or contractors
- Maintain recordkeeping and reporting
- Educate generators and other regulated entities
- Issue waivers
- Support member agencies and SMC Office of Sustainability as needed

## City

- Review SB 1383 Implementation MOU with RethinkWaste
- Hire additional staff as necessary

## COUNCIL DIRECTION

- To prioritize City resources to meet implementation deadline

Requirement	Direction sought
Enforcement ordinance	<ul style="list-style-type: none"> <li>• Amend Municipal Code ordinance</li> </ul>
Procurement	<ul style="list-style-type: none"> <li>• Amend purchasing ordinance</li> <li>• Update City's environmental purchasing policy</li> </ul>
Recology services	<ul style="list-style-type: none"> <li>• Adopt amendments to the Recology franchise agreement</li> </ul>
Food recovery program	<ul style="list-style-type: none"> <li>• Approve the County's MOU</li> </ul>
Record keeping, education, and outreach	<ul style="list-style-type: none"> <li>• Approve SBWMA's MOU</li> </ul>

# Thank you

Tj Carter  
Recycling and Compliance Program Manager  
RethinkWaste  
[tcarter@rethinkwaste.org](mailto:tcarter@rethinkwaste.org)



## STAFF REPORT

**City Council**  
**Meeting Date:** 9/21/2021  
**Staff Report Number:** 21-177-CC

**Commission Reports**      **Consider applicants and make appointments to fill vacancies on the Finance and Audit Committee and Library Commission**

### Recommendation

Staff recommends the City Council consider applicants for appointment to vacant or expired term seats on the following advisory bodies: Finance and Audit Committee (FAC) and Library Commission (LC.)

### Policy Issues

City Council Policy CC-21-004 (Attachment A) establishes the policies, procedures, roles and responsibilities for the City's appointed advisory bodies, including the manner in which members are selected.

### Background

The FAC and LC have unexpected vacancies which should be filled prior to the annual recruitment in April 2022. These positions will fill the current term and expire:

- FAC – April 30, 2022
- LC – April 30, 2024

This recruitment involved a 2-week period of advertisements and announcements.

Following City Council's appointment, the city clerk's office provides onboarding and orientation for the new commission/committee members. This includes the oath of office, commissioner handbook, introduction of commission/committee liaison staff, Form 700 Statement of Economic Interests filing (if applicable), real property reporting form (if applicable), and Brown Act training.

The city clerk's office regularly reviews all agendas and minutes, tracks attendance (Attachment B) and serves as the principal staff liaison contact for all commissions/committees.

### Analysis

Applications are provided as Attachment C. The City Council has the opportunity to ask applicants if they would consider appointments to an alternate commission. These appointments can be made by the City Council at this meeting.

The City received the following applications and are listed in alphabetical order by last name.

- FAC – one vacancy, expiring April 30, 2022:
  - Stuart Soffer

- LC – one vacancy, expiring April 30, 2024:
  - Ken Doniger
  - Kristal Powers
  - Pavneet Singh

### **Impact on City Resources**

Staff support for advisory bodies and funds for recruitment advertising are provided in the annual budget.

### **Public Notice**

Public notification was achieved by posting the agenda, with the agenda items being listed, at least 72 hours prior to the meeting.

### **Attachments**

- A. City Council Policy CC-21-004
- B. Hyperlink – April 13 City Council attendance Staff Report #21-068-CC:  
[menlopark.org/DocumentCenter/View/24570/H2-20200326-CC-Commission-attendance-SR](https://menlopark.org/DocumentCenter/View/24570/H2-20200326-CC-Commission-attendance-SR)
- C. Applications
- D. Applications by District
- E. Current advisory body members by District

Report prepared by:  
Judi A. Herren, City Clerk

# COMMISSIONS/COMMITTEES POLICIES AND PROCEDURES, ROLES AND RESPONSIBILITIES

City Council Procedure #CC-21-004  
 Effective 6/08/2021  
 Resolution No. 6631

ATTACHMENT A



<p><b>Purpose</b></p>
<p>To define policies and procedures and roles and responsibilities for Menlo Park appointed commissions and committees.</p>
<p><b>Authority</b></p>
<p>Upon its original adoption, this policy replaced the document known as “Organization of Advisory Commissions of the City of Menlo Park.”</p>
<p><b>Background</b></p>
<p>The City of Menlo Park currently has eight active Commissions and Committees. The active advisory bodies are: Community Engagement and Outreach Committee, Complete Streets Commission, Environmental Quality Commission, Finance and Audit Committee, Housing Commission, Library Commission, Parks and Recreation Commission, and Planning Commission. Those not specified in the City Code are established by City Council ordinance or resolution. Most of these advisory bodies are established in accordance with Resolution 2801 and its amendments. Within specific areas of responsibility, each advisory body has a primary role of advising the City Council on policy matters or reviewing specific issues and carrying out assignments as directed by the City Council or prescribed by law.</p> <p>Seven of the eight commissions and committees listed above are advisory in nature. The Planning Commission is both advisory and regulatory and organized according to the City Code (Ch. 2.12) and State statute (Government Code 65100 et seq., 65300-65401).</p> <p>The City has an adopted Anti-Harassment and Non-Discrimination Policy (CC-95-001), and a Travel and Expense Policy (CC-91-002), which are also applicable to all advisory bodies.</p>
<p><b>Policies and Procedures</b></p>
<p><u>Relationship to City Council, staff and media</u></p> <ul style="list-style-type: none"> <li>• Upon referral by the City Council, the commission/committee shall study referred matters and return their recommendations and advise to the City Council. With each such referral, the City Council may authorize the City staff to provide certain designated services to aid in the study.</li> <li>• Upon its own initiative, the commission/committee shall identify and raise issues to the City Council's attention and from time to time explore pertinent matters and make recommendations to the City Council.</li> <li>• At a request of a member of the public, the commission/committee may consider appeals from City actions or inactions in pertinent areas and, if deemed appropriate, report and make recommendations to the City Council.</li> <li>• Each commission/committee is required to develop an annual work plan which will be the foundation for the work performed by the advisory body in support of City Council annual work plan. The plan, once finalized by a majority of the commission/committee, will be formally presented to the City Council for direction and approval no later than September 30 of each year and then reported out on by a representative of the advisory body at a regularly scheduled City Council meeting at least annually, but recommended twice a year. The proposed work plan must align with the City Council's adopted work plan. When modified, the work plan must be taken to the City Council for approval. The Planning Commission is exempt from this requirement as its functions are governed by the Menlo Park municipal code (Chapter 2.12) and State law (Government Code 65100 et seq, 65300-65401).</li> <li>• Commissions and committees shall not become involved in the administrative or operational matters of City departments. Members may not direct staff to initiate major programs, conduct large studies or establish department policy. City staff assigned to furnish staff services shall be available to provide general staff assistance, such as preparation of agenda/notice materials and minutes, general review of department programs and activities, and to perform limited studies, program reviews, and other services.</li> </ul>

## COMMISSIONS/COMMITTEES POLICIES AND PROCEDURES, ROLES AND RESPONSIBILITIES

City Council Policy #CC-21-004

Effective 6/08/2021

Resolution No. 6631

2

of a general staff nature. Commissions/Committees may not establish department work programs or determine department program priorities. The responsibility for setting policy and allocating scarce City resources rests with the City's duly elected representatives, the City Council.

- Additional or other staff support may be provided upon a formal request to the City Council.
- The staff liaison shall act as the commission/committee's lead representative to the media concerning matters before the commission/committee. Commission/Committee members should refer all media inquiries to their respective liaisons for response. Personal opinions and comments may be expressed so long as the commission/committee member clarifies that his or her statements do not represent the position of the City Council.
- Commission/Committee members will have mandatory training every two years regarding the Brown Act and parliamentary procedures, anti-harassment training, ethics training, and other training required by the City Council or State Law. The commission/committee members may have the opportunity for additional training, such as training for chair and vice chair. Failure to comply with the mandatory training will be reported to the City Council and may result in replacement of the member by the City Council.
- Requests from commission/committee member(s) determined by the staff liaison to take one hour or more of staff time to complete, must be directed by the City Council.

### Role of City Council commission/committee liaison

City Councilmembers are assigned to serve in a liaison capacity with one or more city commission/committee. The purpose of the liaison assignment is to facilitate communication between the City Council and the advisory body. The liaison also helps to increase the City Council's familiarity with the membership, programs and issues of the advisory body. In fulfilling their liaison assignment, City Councilmembers may elect to attend commission/committee meetings periodically to observe the activities of the advisory body or simply maintain communication with the commission/committee chair on a regular basis.

City Councilmembers should be sensitive to the fact that they are not participating members of the commission/committee, but are there rather to create a linkage between the City Council and commission/committee. In interacting with commissions/committee, City Councilmembers are to reflect the views of the City Council as a body. Being a commission/committee liaison bestows no special right with respect to commission/committee business.

Typically, assignments to commission/committee liaison positions are made at the beginning of a City Council term in December. The Mayor will ask City Councilmembers which liaison assignments they desire and will submit recommendations to the full City Council regarding the various committees, boards, and commissions which City Councilmembers will represent as a liaison. In the rare instance where more than one City Councilmember wishes to be the appointed liaison to a particular commission, a vote of the City Council will be taken to confirm appointments.

### City Staff Liaison

The City has designated staff to act as a liaison between the commission/committee and the City Council. The City shall provide staff services to the commission/committee which will include:

- Developing a rapport with the Chair and commission/committee members
- Providing a schedule of meetings to the City Clerk's Office and commission/committee members, arranging meeting locations, maintaining the minutes and other public records of the meeting, and preparing and distributing appropriate information related to the meeting agenda.
- Advising the commission/committee on directions and priorities of the City Council.
- Informing the commission/committee of events, activities, policies, programs, etc. occurring within the scope of the commission/committee's function.
- Ensuring the City Clerk is informed of all vacancies, expired terms, changes in offices, or any other changes to the commission/committee.

## COMMISSIONS/COMMITTEES POLICIES AND PROCEDURES, ROLES AND RESPONSIBILITIES

City Council Policy #CC-21-004

Effective 6/08/2021

Resolution No. 6631

3

- Providing information to the appropriate appointed official including reports, actions, and recommendations of the committee/commission and notifying them of noncompliance by the commission/committee or chair with City policies.
- Ensuring that agenda items approved by the commission/committee are brought forth in a timely manner taking into consideration staff capacity, City Council priorities, the commission/committee work plan, and other practical matters such as the expense to conduct research or prepare studies, provided appropriate public notification, and otherwise properly prepare the item for commission/committee consideration.
- Take action minutes; upon agreement of the commission, this task may be performed by one of the members (staff is still responsible for the accuracy and formatting of the minutes)
- Maintain a minute book with signed minutes

### Recommendations, requests and reports

As needed, near the beginning of City Council meetings, there will be an item called "Commission/Committee Reports." At this time, commissions/committees may present recommendations or status reports and may request direction and support from the City Council. Such requests shall be communicated to the staff liaison in advance, including any written materials, so that they may be listed on the agenda and distributed with the agenda packet. The materials being provided to the City Council must be approved by a majority of the commission/committee at a commission/committee meeting before submittal to the City Council. The City Council will receive such reports and recommendations and, after suitable study and discussion, respond or give direction.

### City Council referrals

The City Clerk shall transmit to the designated staff liaison all referrals and requests from the City Council for advice and recommendations. The commissions/committees shall expeditiously consider and act on all referrals and requests made by the City Council and shall submit reports and recommendations to the City Council on these assignments.

### Public appearance of commission/committee members

When a commission/committee member appears in a non-official, non-representative capacity before the public, for example, at a City Council meeting, the member shall indicate that he or she is speaking only as an individual. This also applies when interacting with the media and on social media. If the commission/committee member appears as the representative of an applicant or a member of the public, the Political Reform Act may govern this appearance. In addition, in certain circumstances, due process considerations might apply to make a commission/committee member's appearance inappropriate. Conversely, when a member who is present at a City Council meeting is asked to address the City Council on a matter, the member should represent the viewpoint of the particular commission/committee as a whole (not a personal opinion).

### Disbanding of advisory body

Upon recommendation by the Chair or appropriate staff, any standing or special advisory body, established by the City Council and whose members were appointed by the City Council, may be declared disbanded due to lack of business, by majority vote of the City Council.

### Meetings and officers

#### 1. *Agendas/notices/minutes*

- All meetings shall be open and public and shall conduct business through published agendas, public notices and minutes and follow all of the Brown Act provisions governing public meetings. Special, canceled and adjourned meetings may be called when needed, subject to the Brown Act provisions.
- Support staff for each commission/committee shall be responsible for properly noticing and posting all regular, special, canceled and adjourned meetings. Copies of all meeting agendas, notices and



## COMMISSIONS/COMMITTEES POLICIES AND PROCEDURES, ROLES AND RESPONSIBILITIES

City Council Policy #CC-21-004

Effective 6/08/2021

Resolution No. 6631

4

minutes shall be provided to the City Council, City Manager, City Attorney, City Clerk and other appropriate staff, as requested.

- Original agendas and minutes shall be filed and maintained by support staff in accordance with the City's adopted records retention schedule.
- The official record of the commissions/committees will be preserved by preparation of action minutes.

### 2. *Conduct and parliamentary procedures*

- Unless otherwise specified by State law or City regulations, conduct of all meetings shall generally follow Robert's Rules of Order.
- A majority of commission/committee members shall constitute a quorum and a quorum must be seated before official action is taken.
- The chair of each commission/committee shall preside at all meetings and the vice chair shall assume the duties of the chair when the chair is absent.
- The role of the commission/committee chair (according to Roberts Rules of Order): To open the session at the time at which the assembly is to meet, by taking the chair and calling the members to order; to announce the business before the assembly in the order in which it is to be acted upon; to recognize members entitled to the floor; to state and put to vote all questions which are regularly moved, or necessarily arise in the course of the proceedings, and to announce the result of the vote; to protect the assembly from annoyance from evidently frivolous or dilatory motions by refusing to recognize them; to assist in the expediting of business in every compatible with the rights of the members, as by allowing brief remarks when undebatable motions are pending, if s/he thinks it advisable; to restrain the members when engaged in debate, within the rules of order, to enforce on all occasions the observance of order and decorum among the members, deciding all questions of order (subject to an appeal to the assembly by any two members) unless when in doubt he prefers to submit the question for the decision of the assembly; to inform the assembly when necessary, or when referred to for the purpose, on a point of order to practice pertinent to pending business; to authenticate by his/her signature, when necessary, all the acts, orders, and proceedings of the assembly declaring it will and in all things obeying its commands.

### 3. *Lack of a quorum*

- When a lack of a quorum exists at the start time of a meeting, those present will wait 15 minutes for additional members to arrive. If after 15 minutes a quorum is still not present, the meeting will be adjourned by the staff liaison due to lack of a quorum. Once the meeting is adjourned it cannot be reconvened.
- The public is not allowed to address those commissioners present during the 15 minutes the commission/committee is waiting for additional members to arrive.
- Staff can make announcements to the members during this time but must follow up with an email to all members of the body conveying the same information.
- All other items shall not be discussed with the members present as it is best to make the report when there is a quorum present.

### 4. *Meeting locations and dates*

- Meetings shall be held in designated City facilities, as noticed.
- All commissions/committees with the exception of the Community Engagement and Outreach Committee, Planning Commission, and Finance and Audit Committee shall conduct regular meetings once a month. Special meetings may also be scheduled as required by the commission/committee. The Planning Commission shall hold regular meetings twice a month, the Community Engagement and Outreach Committee shall hold meetings as need, and the Finance and Audit Committee shall hold quarterly meetings.
- Monthly regular meetings shall have a fixed date and time established by the commission/committee. Changes to the established regular dates and times are subject to the approval of the City Council. An exception to this rule would include any changes necessitated to fill a temporary need in order for the commission/committee to conduct its meeting in a most efficient

## COMMISSIONS/COMMITTEES POLICIES AND PROCEDURES, ROLES AND RESPONSIBILITIES

City Council Policy #CC-21-004

Effective 6/08/2021

Resolution No. 6631

5

and effective way as long as proper and adequate notification is provided to the City Council and made available to the public.

The schedule of Commission/Committee meetings is as follows:

- Community Engagement and Outreach Committee – as needed
- Complete Streets Commission – Every second Wednesday at 7 p.m.
- Environmental Quality Commission – Every third Wednesday at 6:00 p.m.
- Finance and Audit Committee – Third Wednesday of every quarter at 5:30 p.m.,
- Housing Commission – Every first Wednesday at 6:30 p.m.
- Library Commission – Every third Monday at 6:30 p.m.
- Parks and Recreation Commission – Every fourth Wednesday at 6:30 p.m.
- Planning Commission – Twice a month at 7 p.m.

Each commission/committee may establish other operational policies subject to the approval of the City Council. Any changes to the established policies and procedures shall be subject to the approval of the City Council.

### 5. *Off-premises meeting participation*

While technology allows commission/committee members to participate in meetings from a location other than the meeting location (referred to as “off-premises”), off-premises participation is discouraged given the logistics required to ensure compliance with the Brown Act and experience with technological failures disrupting the meeting. In the event that a commission/committee member believes that his or her participation is essential to a meeting, the following shall apply:

- Any commission/committee member intending to participate from an off-premise location shall inform the staff liaison at least two weeks in advance of the meeting.
- The off-premise location must be identified in the notice and agenda of the meeting.
- Agendas must be posted at the off-premise location.
- The off-premise location must be accessible to the public and be ADA compliant.
- The commission/committee member participating at a duly noticed off-premises location does not count toward the quorum necessary to convene a meeting of the commission/committee.
- For any one meeting, no more than one commission/committee member may participate from an off-premise location.
- All votes must be by roll call.

### 6. *Selection of chair and vice chair*

- The chair and vice chair shall be selected in May of each year by a majority of the members and shall serve for one year or until their successors are selected.
- Each commission/committee shall annually rotate its chair and vice chair.

## G. Memberships

### *Appointments/Oaths*

- The City Council is the appointing body for all commissions/committees. All members serve at the pleasure of the City Council for designated terms.
- All appointments and reappointments shall be made at a regularly scheduled City Council meeting, and require an affirmative vote of not less than a majority of the City Council present.
- Before taking office, all members must complete an Oath of Allegiance required by Article XX, §3, of the Constitution of the State of California. All oaths are administered by the City Clerk or his/her designee.
- Appointments made during the middle of the term are for the unexpired portion of that term.

## COMMISSIONS/COMMITTEES POLICIES AND PROCEDURES, ROLES AND RESPONSIBILITIES

City Council Policy #CC-21-004

Effective 6/08/2021

Resolution No. 6631

6

### *Application and selection process*

- The application process begins when a vacancy occurs due to term expiration, resignation, removal or death of a member.
- The application period will normally run for a period of four weeks from the date the vacancy occurs. If there is more than one concurrent vacancy in a Commission, the application period may be extended. Applications are available from the City Clerk's office and on the City's website.
- The City Clerk shall notify members whose terms are about to expire whether or not they would be eligible for reappointment. If reappointment is sought, an updated application will be required.
- Applicants are required to complete and return the application form for each commission/committee they desire to serve on, along with any additional information they would like to transmit, by the established deadline. Applications sent by email are accepted; however, the form submitted must be signed.
- After the deadline of receipt of applications, the City Clerk shall schedule the matter at the next available regular City Council meeting. All applications received will be submitted and made a part of the City Council agenda packet for their review and consideration. If there are no applications received by the deadline, the City Clerk will extend the application period for an indefinite period of time until sufficient applications are received.
- Upon review of the applications received, the City Council reserves the right to schedule or waive interviews, or to extend the application process in the event insufficient applications are received. In either case, the City Clerk will provide notification to the applicants of the decision of the City Council.
- If an interview is requested, the date and time will be designated by the City Council. Interviews are open to the public.
- The selection/appointment process by the City Council shall be conducted open to the public. Nominations will be made and a vote will be called for each nomination in the order received. Applicants receiving the highest number of affirmative votes from a majority of the City Council present shall be appointed. The number of votes for each City Councilmember is limited to the number of vacancies.
- Following a City Council appointment, the City Clerk shall notify successful and unsuccessful applicants accordingly, in writing. Appointees will receive copies of the City's Non-Discrimination and Sexual Harassment policies, and disclosure statements for those members who are required to file under State law as designated in the City's Conflict of Interest Code. Copies of the notification will also be distributed to support staff and the commission/committee chair.
- An orientation will be scheduled by the City Clerk following an appointment (but before taking office) and a copy of this policy document will be provided at that time.

### *Attendance*

- An Attendance Policy (CC-91-001), shall apply to all advisory bodies. Provisions of this policy are listed below.
- A compilation of attendance will be submitted to the City Council at least annually listing absences for all commissions/committee members.
- Absences, which result in attendance at less than two-thirds of their meetings during the calendar year, will be reported to the City Council and may result in replacement of the member by the City Council.
- Any member who feels that unique circumstances have led to numerous absences can appeal directly to the City Council for a waiver of this policy or to obtain a leave of absence.
- While it is expected that members be present at all meetings, the chair and staff liaison should be notified if a member knows in advance that he/she will be absent.
- When reviewing commissioners for reappointment, overall attendance at full commission meetings will be given significant consideration.

## COMMISSIONS/COMMITTEES POLICIES AND PROCEDURES, ROLES AND RESPONSIBILITIES

City Council Policy #CC-21-004

Effective 6/08/2021

Resolution No. 6631

7

### *Compensation*

- Members shall serve without compensation (unless specifically provided) for their services, provided, however, members shall receive reimbursement for necessary travel expenses and other expenses incurred on official duty when such expenditures have been authorized by the City Council (See Policy CC-91-002).

### *Conflict of interest and disclosure requirements*

- A Conflict of Interest Code has been updated and adopted by the City Council and the Community Development Agency pursuant to Government Code §87300 et seq. Copies of this Code are filed with the City Clerk. Pursuant to the adopted Conflict of Interest Code, members serving on the Planning Commission are required to file a Statement of Economic Interest with the City Clerk to disclose personal interest in investments, real property and income. This is done within 30 days of appointment and annually thereafter. A statement is also required within 30 days after leaving office.
- If a public official has a conflict of interest, the Political Reform Act may require the official to disqualify himself or herself from making or participating in a governmental decision, or using his or her official position to influence a governmental decision. Questions in this regard may be directed to the City Attorney.
- In accordance with Resolution No. 6622, current and future members of the Community Engagement and Outreach Committee, Complete Streets Commission, and Housing Commission, are required to report any and all real property in Menlo Park for impacting land use, real property, and the housing element.

### *Qualifications, compositions, number*

- In most cases, members shall be residents of the City of Menlo Park and at least 18 years of age.
- Current members of any other City commission/committee are disqualified for membership, unless the regulations for that advisory body permit concurrent membership. Commission/Committee members are strongly advised to serve out the entirety of the term of their current appointment before seeking appointment on another commission/committee.
- Commission/Committee members shall be permitted to retain membership while seeking any elective office. However, members shall not use the meetings, functions or activities of such bodies for purposes of campaigning for elective office.
- There shall be seven (7) members on each commission/committee with the exception of:
  - Community Engagement and Outreach Committee – fourteen (14) members
  - Complete Streets Commission – nine (9) members
  - Finance and Audit Committee – five (5) members
  - Housing Commission – seven (7) members
  - Library Commission – eleven (11) members

### *Reappointments, resignations, removals*

- Incumbents seeking a reappointment are required to complete and file an application with the City Clerk by the application deadline. No person shall be reappointed to a commission/committee who has served on that same body for two consecutive terms; unless a period of one year has lapsed since the returning member last served on that commission/committee (the one-year period is flexible subject to City Council's discretion).
- Resignations must be submitted in writing to the City Clerk, who will distribute copies to City Council and appropriate staff.
- The City Council may remove a member by a majority vote of the City Council without cause, notice or hearing.

**COMMISSIONS/COMMITTEES POLICIES AND PROCEDURES, ROLES AND RESPONSIBILITIES**

City Council Policy #CC-21-004

Effective 6/08/2021

Resolution No. 6631

*Term of office*

- Unless specified otherwise, the term of office for all commission/committee shall be four (4) years unless a resignation or a removal has taken place. The Finance and Audit Committee term of office shall be two (2) years. The Community Engagement and Outreach Committee term is for eighteen (18) months.
- If a person is appointed to fill an unexpired term and serves less than two years, that time will not be considered a full term. However, if a person is appointed to fill an unexpired term and serves two years or more, that time will be considered a full term.
- Terms are staggered to be overlapping four-year terms, so that all terms do not expire in any one year.
- If a member resigns before the end of his/her term, a replacement serves out the remainder of that term.

*Vacancies*

- Vacancies are created due to term expirations, resignations, removals or death.
- Vacancies are listed on the City Council agenda and posted by the City Clerk in the City Council Chambers bulletin board and on the city website.
- Whenever an unscheduled vacancy occurs in any commission/committee, a special vacancy notice shall be posted within 20 days after the vacancy occurs. Appointment shall not be made for at least 10 working days after posting of the notice (Government Code 54974).
- On or before December 31 of each year, an appointment list of all regular advisory commissions/committees of the City Council shall be prepared by the City Clerk and posted in the City Council Chambers bulletin board and on the City's website. This list is also available to the public. (Government Code 54972, Maddy Act).

**Roles and Responsibilities**

**Community Engagement and Outreach Committee**

The Housing Element Community Engagement and Outreach Committee (CEOC) assists the City in ensuring a broad and inclusive community outreach and engagement process. Committee members help guide and provide feedback on the types and frequency of activities/events/meetings and the strategies and methods for communicating with the various stakeholders in the community.

Roles and responsibilities:

- Serve as an ambassador of the project and encourage people to participate in the process
- Help guide and provide feedback on the community engagement plan
- Serve as a community resource to provide information to and receive input from the community on matters related to community engagement and public outreach

Complete Streets Commission

The Complete Streets Commission is charged primarily with advising the City Council on multi-modal transportation issues according to the goals and policies of the City's general plan. This includes strategies to encourage safe travel, improve accessibility, and maintaining a functional and efficient transportation network for all modes and persons traveling within and around the City. The Complete Streets Commission's responsibilities would include:

- Coordination of multi-modal (motor vehicle, bicycle, transit and pedestrian) transportation facilities
- Advising City Council on ways to encourage vehicle, multi-modal, pedestrian and bicycle safety and accessibility for the City supporting the goals of the General Plan
- Coordination on providing a citywide safe routes to school plan
- Coordination with regional transportation systems
- Establishing parking restrictions and requirements according to Municipal Code sections 11.24.026 through 11.24.028

## COMMISSIONS/COMMITTEES POLICIES AND PROCEDURES, ROLES AND RESPONSIBILITIES

City Council Policy #CC-21-004

Effective 6/08/2021

Resolution No. 6631

9

### Environmental Quality Commission

The Environmental Quality Commission is charged primarily with advising the City Council on matters involving environmental protection, improvement and sustainability. Specific focus areas include:

- Preserving heritage trees
- Using best practices to maintain city trees
- Preserving and expanding the urban canopy
- Making determinations on appeals of heritage tree removal permits
- Administering annual Environmental Quality Awards program
- Organizing annual Arbor Day Event; typically, a tree planting event
- Advising on programs and policies related to protection of natural areas, recycling and waste reduction, environmentally sustainable practices, air and water pollution prevention, climate protection, and water and energy conservation.

### Finance and Audit Committee

The Finance and Audit Committee is charged primarily to support delivery of timely, clear and comprehensive reporting of the City's fiscal status to the community at large. Specific focus areas include:

- Review the process for periodic financial reporting to the City Council and the public, as needed
- Review financial audit and annual financial report with the City's external auditors
- Review of the resolution of prior year audit findings
- Review of the auditor selection process and scope, as needed

### Housing Commission

The Housing Commission is charged primarily with advising the City Council on housing matters including housing supply and housing related problems. Specific focus areas include:

- Community attitudes about housing (range, distribution, racial, social-economic problems)
- Programs for evaluating, maintaining, and upgrading the distribution and quality of housing stock in the City
- Planning, implementing and evaluating City programs under the Housing and Community Development Act of 1974
- Members serve with staff on a loan review committee for housing rehabilitation programs and a first time homebuyer loan program
- Review and recommend to the City Council regarding the Below Market Rate (BMR) program
- Initiate, review and recommend on housing policies and programs for the City
- Review and recommend on housing related impacts for environmental impact reports
- Review and recommend on State and regional housing issues
- Review and recommend on the Housing Element of the General Plan
- The five most senior members of the Housing Commission also serve as the members of the Relocation Appeals Board (City Resolution 4290, adopted June 25, 1991).

### Library Commission

The Library Commission is charged primarily with advising the City Council on matters related to the maintenance and operation of the City's libraries and library systems. Specific focus areas include:

- The scope and degree of library activities
- Maintenance and protection of City libraries
- Evaluation and improvement of library service
- Acquisition of library materials
- Coordination with other library systems and long range planning
- Literacy and ESL programs

**COMMISSIONS/COMMITTEES POLICIES AND PROCEDURES, ROLES AND RESPONSIBILITIES**

City Council Policy #CC-21-004

Effective 6/08/2021

Resolution No. 6631

Parks and Recreation Commission

The Parks and Recreation Commission is charged primarily with advising the City Council on matters related to City programs and facilities dedicated to recreation. Specific focus areas include:

- Those programs and facilities established primarily for the participation of and/or use by residents of the City, including adequacy and maintenance of such facilities as parks and playgrounds, recreation buildings, facilities and equipment
- Adequacy, operation and staffing of recreation programs
- Modification of existing programs and facilities to meet developing community needs
- Long range planning and regional coordination concerning park and recreational facilities

Planning Commission

The Planning Commission is organized according to State Statute.

- The Planning Commission reviews development proposals on public and private lands for compliance with the General Plan and Zoning Ordinance.
- The Commission reviews all development proposals requiring a use permit, architectural control, variance, minor subdivision and environmental review associated with these projects. The Commission is the final decision-making body for these applications, unless appealed to the City Council.
- The Commission serves as a recommending body to the City Council for major subdivisions, rezoning's, conditional development permits, Zoning Ordinance amendments, General Plan amendments and the environmental reviews and Below Market Rate (BMR) Housing Agreements associated with those projects.
- The Commission works on special projects as assigned by the City Council.

**Special Advisory Bodies**

The City Council has the authority to create standing committees, task forces or subcommittees for the City, and from time to time, the City Council may appoint members to these groups. The number of persons and the individual appointee serving on each group may be changed at any time by the City Council. There are no designated terms for members of these groups; members are appointed by and serve at the pleasure of the City Council.

Any requests of city commissions or committees to create such ad hoc advisory bodies shall be submitted in writing to the City Clerk for City Council consideration and approval.

**Procedure history**

Action	Date	Notes
Procedure adoption	1991	Resolution No. 3261
Procedure adoption	2001	
Procedure adoption	2011	
Procedure adoption	2013	Resolution No. 6169
Procedure adoption	2017	Resolution No. 6377
Procedure adoption	6/8/2021	Resolution No. 6631

# COMMISSION AND COMMITTEE APPLICATION

City Manager's Office - City Clerk  
701 Laurel St., Menlo Park, CA 94025  
tel 650-330-6620 fax 650-328-7935

ATTACHMENT C



Please type or print clearly. You may attach additional pages, if necessary. This is a public document.

Date: August 22, 2021

Commission or committee of interest: Finance and Audit Committee

Name: Stuart Soffer

Education: BS Computer Science, University of Wisconsin

Civic affiliations and community activities, including service on other commissions or committees:

Former MP Planning Commission  
Former MP Finance Committee  
Former MP Chamber of Commerce member  
Blogger on Menlo Park Almanac

Describe your understanding of the responsibilities of the commission or committee that you are applying for and how your personal community or professional experience relate to these responsibilities:

Review periodic financial statements, including an annual report

Describe why you want to serve on this commission or committee and what you hope to accomplish as a member:

Happy to lend my experience and historic knowledge

Signature

August 22, 2021

Date

## OFFICE USE ONLY:

Application received: August 22, 2021

Considered by City Council: \_\_\_\_\_

Considered by City Council: \_\_\_\_\_

Considered by City Council: \_\_\_\_\_

If appointed, term ends: April 30, 2022

Address verified in City Limits (if necessary):  By: JAH

Appointed:  Yes  No (Initials)

Appointed:  Yes  No

Appointed:  Yes  No



27  
since 1994

<b>Personal information:</b>			
Name: STuart Soffer	Number of years as a Menlo Park resident: 27 since 1994		
Resident address: [REDACTED]	City: Meno Park	State: CA	Zip: 94025
Mailing address (if different):	City:	State:	Zip:
Phone: [REDACTED]	Email: [REDACTED]		
Business address:	City:	State:	Zip:
Business phone:			
How did you hear about this opportunity:			
<input type="checkbox"/> Local newspaper <input checked="" type="checkbox"/> Email <input type="checkbox"/> City website <input type="checkbox"/> Nextdoor <input type="checkbox"/> Patch.com <input type="checkbox"/> Other _____			
If I am appointed, the City is authorized to post the following information on the city website (please select at least one):	Cellphone:	<input checked="" type="radio"/> Yes	<input type="radio"/> No
	Business phone:	<input type="radio"/> Yes	<input type="radio"/> No
	Home phone:	<input type="radio"/> Yes	<input type="radio"/> No
	Email:	<input type="radio"/> Yes	<input type="radio"/> No

# COMMISSION AND COMMITTEE APPLICATION

City Manager's Office - City Clerk  
701 Laurel St., Menlo Park, CA 94025  
tel 650-330-6620 fax 650-328-7935



Please type or print clearly. You may attach additional pages, if necessary. This is a public document.

Date: 15sept2021

Commission or committee of interest: Library

Name: Ken Doniger

Education: UC Berkeley

Civic affiliations and community activities, including service on other commissions or committees:

Describe your understanding of the responsibilities of the commission or committee that you are applying for and how your personal community or professional experience relate to these responsibilities:

The committee exists to support and expand the library.

Describe why you want to serve on this commission or committee and what you hope to accomplish as a member:

I've used and enjoyed Menlo Park's library for many years and I'd like to give back. I think the idea of a library is remarkable: a place where you can take books away without charge, and they trust you to bring them back. An institution based on trusting strangers and spreading knowledge should be preserved and cultivated.

\_\_\_\_\_  
Signature

15sept2021

\_\_\_\_\_  
Date

## OFFICE USE ONLY:

Application received: September 15, 2021

Considered by City Council: \_\_\_\_\_

Considered by City Council: \_\_\_\_\_

Considered by City Council: \_\_\_\_\_

If appointed, term ends: April 30, 2021

Address verified in City Limits (if necessary):  By: JAH  
(Initials)

Appointed:  Yes  No

Appointed:  Yes  No

Appointed:  Yes  No

Personal information:			
Name: Ken Doniger		Number of years as a Menlo Park resident: 37	
Resident address: [REDACTED]	City: Menlo Park	State: CA	Zip: 94025
Mailing address (if different):	City:	State:	Zip:
Phone: [REDACTED]	Email: [REDACTED]		
Business address:	City:	State:	Zip:
Business phone:			
How did you hear about this opportunity: <input type="checkbox"/> Local newspaper <input checked="" type="checkbox"/> Email <input type="checkbox"/> City website <input type="checkbox"/> Nextdoor <input type="checkbox"/> Patch.com <input type="checkbox"/> Other _____			
If I am appointed, the City is authorized to post the following information on the city website (please select at least one):	Cellphone:	<input type="radio"/> Yes	<input type="radio"/> No
	Business phone:	<input type="radio"/> Yes	<input type="radio"/> No
	Home phone:	<input type="radio"/> Yes	<input type="radio"/> No
	Email:	<input checked="" type="radio"/> Yes	<input type="radio"/> No

# COMMISSION AND COMMITTEE APPLICATION

City Manager's Office - City Clerk  
701 Laurel St., Menlo Park, CA 94025  
tel 650-330-6620 fax 650-328-7935



Please type or print clearly. You may attach additional pages, if necessary. This is a public document.

Date: 09/03/2021

Commission or committee of interest: Library Commission

Name: Kristal Powers

Education: Master's Degree in Nursing Administration from SFSU, BA in History from UCLA

Civic affiliations and community activities, including service on other commissions or committees:

I do not have any formal previous experience. However, I do work for the County of San Mateo and have attended Board of Supervisor meetings. I also work on several steering committees in my current role and can appreciate how committees function.

Describe your understanding of the responsibilities of the commission or committee that you are applying for and how your personal community or professional experience relate to these responsibilities:

I am will be available for all designated meetings. I plan to collaborate with the committee in exploring how the library functions are currently working and how services can be enhanced. Preserving the library is something I am passionate about and hope to contribute ideas on how to do this logistically, financially and sustainably. Further, I would like to ensure that resources are available not only in the form of books, but classes as well. Whether reading time or ESL focused classes I want to ensure that the community can count on the library to enhance a sense of togetherness and education.

Describe why you want to serve on this commission or committee and what you hope to accomplish as a member:

I am passionate about our community and preserving culture for generations to come. I would like to be part of the process in ensuring that this precious resource is available for all.

Signature

9/3/21

Date

### OFFICE USE ONLY:

Application received: September 3, 2021

Considered by City Council: \_\_\_\_\_

Considered by City Council: \_\_\_\_\_

Considered by City Council: \_\_\_\_\_

If appointed, term ends: April 30, 2024

Address verified in City Limits (if necessary):  By: JAH

Appointed:  Yes  No

Appointed:  Yes  No

Appointed:  Yes  No

(Initials)

<b>Personal information:</b>			
Name: Kristal Powers		Number of years as a Menlo Park resident:	
Resident address: [REDACTED]	City: Menlo Park	State: CA	Zip: 94025
Mailing address (if different):	City:	State:	Zip:
Phone: [REDACTED]	Email: [REDACTED]		
Business address:	City:	State:	Zip:
Business phone:			
How did you hear about this opportunity:			
<input type="checkbox"/> Local newspaper <input type="checkbox"/> Email <input type="checkbox"/> City website <input type="checkbox"/> Nextdoor <input type="checkbox"/> Patch.com <input checked="" type="checkbox"/> Other <u>Menlo Park Facebook Group</u>			
If I am appointed, the City is authorized to post the following information on the city website (please select at least one):		Cellphone:	<input type="radio"/> Yes <input type="radio"/> No
		Business phone:	<input type="radio"/> Yes <input type="radio"/> No
		Home phone:	<input type="radio"/> Yes <input type="radio"/> No
		Email:	<input checked="" type="radio"/> Yes <input type="radio"/> No

# COMMISSION AND COMMITTEE APPLICATION

City Manager's Office - City Clerk  
 701 Laurel St., Menlo Park, CA 94025  
 tel 650-330-6620 fax 650-328-7935



<b>Please type or print clearly. You may attach additional pages, if necessary. This is a public document.</b>
Date: 9/16/2021
Commission or committee of interest: Library Commission
Name: Pavneet Singh
Education: MS International Economics and Foreign Policy (Georgetown); BS, Business Administration; BA Political Economy (UC Berkeley)
Civic affiliations and community activities, including service on other commissions or committees: Currently a consultant to the Department of Defense at the Defense Innovation Unit in Mountain View Non-Resident Fellow at the Brookings Institution
Describe your understanding of the responsibilities of the commission or committee that you are applying for and how your personal community or professional experience relate to these responsibilities: The library commission performs a range of duties, both from an administrative level to providing strategic counsel on the future of this important community institution. I look forward to providing advice and counsel on library budget discussions, resource allocation decisions, and how to think about positioning the library as a place where citizens of all ages want to visit, utilize and maintain. As a member of the commission, I expect to bring in lessons learned from other library systems and identify trends in knowledge collection and dissemination that reflect changing trends in the community and among core user demographics.
Describe why you want to serve on this commission or committee and what you hope to accomplish as a member: My career has largely been in public service at the federal level. From 2010-2015, I served on the National Security Council and National Economic Council at the White House. Since moving to Menlo Park nearly six years ago, I have really learned that the strength of a nation starts at the community level. Since moving to Menlo Park, I have been fortunate to benefit from the various resources that the city provides. From public parks to community activities, this city does everything it can to cultivate a strong social fabric. And I have built many enduring relationships through interactions provided by the city. My kids (age 4 and 1) and I spend a lot of time at the library, and during the pandemic, the steps that the library team took to stay open and service the community deserve high praise. I am in a position now to give back to the community and given my familiarity with the library, and strong interest in the role a library can play in the community I would love to contribute where I can.

  
 Signature

9/16/2021  
 Date

<b>OFFICE USE ONLY:</b>	
Application received: <u>September 16, 2021</u>	Address verified in City Limits (if necessary): <input checked="" type="checkbox"/> By: <u>JAH</u> (Initials)
Considered by City Council: _____	Appointed: <input type="checkbox"/> Yes <input type="checkbox"/> No
Considered by City Council: _____	Appointed: <input type="checkbox"/> Yes <input type="checkbox"/> No
Considered by City Council: _____	Appointed: <input type="checkbox"/> Yes <input type="checkbox"/> No
If appointed, term ends <u>April 30, 2024</u>	

Personal information:			
Name: Pavneet Singh		Number of years as a Menlo Park resident: 5.5	
Resident address: [REDACTED]		City: Menlo Park	State: CA Zip: 94025
Mailing address (if different):		City:	State: Zip:
Phone: [REDACTED]		Email: [REDACTED]	
Business address:		City:	State: Zip:
Business phone:			
How did you hear about this opportunity: <input type="checkbox"/> Local newspaper <input type="checkbox"/> Email <input checked="" type="checkbox"/> City website <input type="checkbox"/> Nextdoor <input type="checkbox"/> Patch.com <input type="checkbox"/> Other _____			
If I am appointed, the City is authorized to post the following information on the city website (please select at least one):		Cellphone: Business phone: Home phone: Email:	<input type="radio"/> Yes <input type="radio"/> No <input type="radio"/> Yes <input type="radio"/> No <input type="radio"/> Yes <input type="radio"/> No <input checked="" type="radio"/> Yes <input type="radio"/> No

Table 1: Finance and Audit Committee applications by District

Applications by District	Applicant	District
Finance and Audit Committee	Stuart Soffer	3

Table 2: Library Commission applications by District

Applications by District	Applicant	District
Library Commission	Ken Doniger	2
Library Commission	Kristal Powers	4
Library Commission	Pavneet Singh	4



Table 1: Community Engagement and Outreach Committee by district		
Applicant	Last appointment date	District
Bortnik, Michal	5/25/2021	4
Cline, Rich	5/25/2021	4
Dao, Tiffany	5/25/2021	4
DiSiena, Yadira	5/25/2021	1
Feldman, Lesley	5/25/2021	2
Fennell, Max	5/25/2021	3
McMahon, Dan	5/25/2021	2
Ollarvia, Nehezi	5/25/2021	2
Robledo, Victoria	5/25/2021	1
Spaulding, Aaron	5/25/2021	3
Tronson, Soody	5/25/2021	4
Vacant	6/8/2021	5

Table 2: Complete Streets Commission applications by district		
Applicant	Last appointment date	District
Altman, Brian	5/25/2021	4
Berhoozi, Katie	6/9/2020	2
Cebrian, Jacqueline	4/16/2019	1
Cole, Sally	5/25/2021	4
Cromie, John	4/16/2019	2
Jensen, Jk	5/25/2021	3
King, Lizbeth	5/25/2021	5
Lee, Lydia	4/24/2018	3
Levin, Adina	4/24/2018	4

Table 3: Environmental Quality Commission by district		
Applicant	Last appointment date	District
Elkins, Leah	10/13/2020	2
Evans, Angela	5/25/2021	5
Gaillard, Josie	4/16/2019	3
Kabat, Tom	4/24/2018	2
London, Janelle	6/9/2020	5
Payne, James	6/9/2020	1
Price, Ryann	4/24/2018	2

Table 4: Finance and Audit Committee by district		
Applicant	Last appointment date	District
Combs, Drew - City Council	12/15/2020	2
Mueller, Ray - City Council	12/15/2020	5
Norrington, Matt	5/25/2021	3
Royse, Roger	4/24/2018	4
Westcott, Brian	6/4/2019	5
Wong, Carol	5/25/2021	4

Table 5: Housing Commission by district		
Applicant	Last appointment date	District
Bigelow, Lauren	4/16/2019	5
Grove, Karen	7/18/2017	5
Horst, Rachel	5/25/2021	4
Leitch, Heather	5/25/2021	2
Merriman, Nevada	5/25/2021	2
Nguyen, Chelsea	5/25/2021	3
Pimentel, John	4/16/2019	3

Table 6: Library Commission by district		
Applicant	Last appointment date	District
Cohen, Alan	4/24/2018	5
Erhart, David	4/16/2019	1
Hadrovic, Katie	4/24/2018	2
Lee, Aldora	5/25/2021	4
Leep, Kristen	4/16/2019	4
Velagapudi, Vamsi	5/25/2021	4
Vacant		

Table 7: Parks and Recreation Commission by district		
Applicant	Last appointment date	District
Baskin, Jennifer	6/9/2020	4
Brosnan, Aurora	6/8/2021	4
Bryman, Marc	4/16/2019	3
Diepenbrock, Peter	10/15/2019	4
Joshua, Peter	5/25/2021	2
Payne, Dana	4/24/2018	1
Thomas, David	6/8/2021	4

Table 8: Planning Commission by district		
Applicant	Last appointment date	District
Barnes, Andrew	6/9/2020	2
DeCardy, Chris	4/16/2019	2
Doran, Michael	1/29/2019	4
Harris, Cynthia	5/25/2021	3
Kennedy, Camille	4/24/2018	4
Riggs, Henry	6/9/2020	2
Tate, Michele	4/16/2019	1



**REGULAR MEETING MINUTES – DRAFT**

**Date:** 8/31/2021  
**Time:** 5:00 p.m.  
**Location:** Zoom

**Regular Session (Zoom.us/join – ID# 998 8073 4930)**

**A. Call To Order**

Mayor Combs called the meeting to order at 5:09 p.m.

**B. Roll Call**

**Present:** Combs, Mueller (exited the meeting at 10:23 p.m.), Nash, Taylor, Wolosin  
**Absent:** None  
**Staff:** City Manager Starla Jerome-Robinson, City Attorney Nira F. Doherty, City Clerk Judi A. Herren

**C. Agenda Review**

The City Council pulled items G1. and G2. for discussion and rearranged the agenda order for item I1.

**D. Public Comment**

- Orville spoke in opposition of the 5 p.m. meeting start time due to timing conflicts.

**E. Presentations and Proclamations**

**E1. Proclamation: Recognizing Rayna Lehman (Attachment)**

Mayor Combs read the proclamation.

Rayna Lehman accepted the proclamation.

**F. Study Session**

**F1. Receive Environmental Quality Commission's recommendations to electrify 95 percent of existing buildings in Menlo Park and provide direction on next steps (Staff Report #21-170-CC) (Presentation)**

Web form public comment on item F1.

Sustainability Manager made a presentation (Attachment).

Environmental Quality Commissioner Josie Gaillard a presentation (Attachment).

- Lyn requested clarification on why residential is impacted and not commercial.
- Jared Johnson read a letter from a student in support of the Environmental Quality Commission's (EQC) recommendations.
- Bruce Naegel spoke in support of the EQC's recommendations.

- Donnell Baird spoke in support of the EQC's recommendations.
- Orville spoke in opposition of the EQC's recommendations.
- James Tuleya spoke in support of the EQC's recommendations.
- Michael DeMoss spoke in support of putting electrification on a future ballot.
- Dashiell Leeds spoke in support of the EQC's recommendations.
- Mahsid Saadat spoke in opposition of the EQC's recommendations and provided information on natural gas usage.
- Bret Anderson spoke in support of the EQC's recommendations.
- Martin Rosenblum requested clarification on the exception of commercial, industrial, and institutions.
- Margaret Bruce spoke in support of the EQC's recommendations.
- Nicole Kemeny spoke in support of the EQC's recommendations.
- Bellamy Cramer spoke in support of the EQC's recommendations.
- Adina Levin spoke in support of the EQC's recommendations.
- James Pistorino spoke in opposition of the EQC's recommendations.
- James Lockhart spoke in opposition of the EQC's recommendations and the impacts to older homes.
- Robert Gould spoke in support of the EQC's recommendations.
- Eduardo Pelegri-Llopart spoke in support of the EQC's recommendations.
- Robert Whitehair spoke in support of the EQC's recommendations.
- Kevin Ma spoke in support of the EQC's recommendations.
- Mickie Winkler requested clarification on the impact to the electric power supply.
- Brian Gilmer spoke in opposition of the EQC's recommendations.
- Diane Bailey spoke in support of the EQC's recommendations and read a comment from Jan Pepper.
- Randy Avalos spoke in support of the EQC's recommendations and increased public engagement.
- Lisa J. spoke in support of the EQC's recommendations.
- Kathleen Goforth spoke in support of the EQC's recommendations.

The City Council received clarification on low-income and the turnkey installation program, the use of user utility tax (UUT), staff and EQC recommendations, and greenhouse gas emissions from existing commercial buildings.

The City Council discussed the process of the current CAP, appliances impacted by electrification, consideration of a pilot program, the permitting process, appliances impacted by an ordinance, Peninsula Clean Energy assistance programs and loans, resource constraints, the EQC recommendations, and non-push polling to identify where the public is on the issues to establish a baseline.

The City Council spoke in support of five of the six recommendations presented by Environmental Quality Commissioner Gaillard (1, 2, 3, 5, and 6) and directed staff to pursue collecting the UUT at the voter-approved levels and establishing a dedicated fund to support building decarbonization, identify partners for funding and financing programs, including a specific low-income turnkey program, develop of program proposals to reduce "hassle factor" for building owners, begin formal public engagement immediately, and develop long term plan/roadmap to meet CAP goal No. 1

(Attachment).

Staff indicated that they would return back to the City Council with defined scopes, timelines, and identification of additional resources as necessary to accomplish the direction provided by the City Council.

The City Council took a recess at 8:23 p.m.

The City Council reconvened at 8:46 p.m.

Mayor Combs reordered the agenda.

## I. Regular Business

### I1. Adopt Resolution No. 6659 establishing the Independent Redistricting Commission (Staff Report #21-168-CC) (Presentation)

Web form public comment on item I1.

City Clerk Judi A. Herren and Assistant City Attorney Denise Bazzano made the presentation  
(Attachment).

- Helen Grieco spoke in support of an independent redistricting commission (IRC) and increasing public engagement.

The City Council received clarification on provision of appointing one member per district to an IRC, member eligibility restriction related to the \$500+ donation to a City Council campaign, election timelines with newly drawn District boundaries and the voting cycle, defining “sufficient” related to the number of applications received, residency length requirement, the definition of diversity, IRCs ability to hire consultants, and translation services.

The City Council discussed requiring a minimum of 12 qualified applicants before appointments can be made, adding a provision to ensure a minimum of one IRC member per district, and oversight of the IRC.

The City Council directed staff to add “ability” to definition of diversity and the addition of a provision that demographer has already been selected and no consultant(s) is required for this redistricting cycle.

**ACTION:** Motion and second (Wolosin/ Taylor), to adopt Resolution No. 6659 establishing the Independent Redistricting Commission, to add “ability” to the definition of diversity as defined in the resolution, adding reference that the demographer has already been selected and no consultant(s) are required for this redistricting cycle, and add language that application deadline can be extended for 2-weeks if nine or less applications are received, passed 3-2 (Mueller and Combs dissenting).

City Councilmember Mueller exited the meeting.

## G. Consent Calendar

- G1. Accept the City Council meeting minutes for July 20 and 29, and August 16 and 17, 2021 (Attachment)

**ACTION:** Motion and second (Combs/ Nash), to accept the City Council meeting minutes for July 20 and 29, and August 16 and 17, 2021, passed 3-0 (Taylor abstaining from the July 20, 2021 minutes and Mueller absent).

- G2. Adopt Resolution No. 6654 approving the funding agreement with Hibiscus Properties for the construction of raised median islands on Chilco Street and authorizing the city manager to execute the funding agreement (Staff Report #21-163-CC)

Mayor Combs was recused from item G2. and exited the meeting.

The City Council continued item G2. to a future meeting.

Mayor Combs returned to the meeting.

- G3. Adopt Resolution No. 6655 approving the funding agreement with 1540 El Camino Real developer for median landscaping improvements along El Camino Real, between Glenwood Avenue and Encinal Avenue and authorizing the city manager to execute the funding agreement (Staff Report #21-164-CC)

- G4. Adopt Resolution No. 6656 approving Alcoholic Beverage Control grant (Staff Report #21-165-CC)

- G5. Adopt Resolution No. 6657 and approve agreement with Turbo Data Systems, Inc. for citation processing and payment and adjudication services (Staff Report #21-166-CC)

**ACTION:** Motion and second (Combs/ Nash), to approve consent calendar items G3. G4. and G5., passed 4-0 (Mueller absent).

## H. Public Hearing

Item H1. was removed from the agenda.

- ~~H1. Consider two appeals of the Planning Commission certification of a final environmental impact report and approval of a use permit, architectural control, below market rate housing agreement, and community amenities operating covenant, and consider the Planning Commission recommendation to approve a vesting tentative map for a major subdivision for the proposed Menlo Uptown project with 483 multifamily dwelling units comprised of 441 rental units and 42 for sale condominium units and approximately 2,940 square feet of commercial space at 141 Jefferson Drive and 180-186 Constitution Drive (Staff Report #21-169-CC)~~

- H2. Consider an appeal of the Planning Commission's denial of a use permit for the sale of beer and wine for off-premises consumption every day from 6 a.m. to 2 a.m. the following day, and for 24-hour operations of an existing service station and associated convenience store at 710 Willow Road (Staff Report #21-167-CC) (Presentation)

Web form public comment on item H2.

Senior Planner Tom Smith made the presentation (Attachment).

Appellant Aparna Saha made a presentation.

Mayor Combs opened the public hearing.

- Tricia Barr spoke in support of denying the appeal.
- Brian Gilmer spoke in support of denying the appeal.
- Jeffrey Chen spoke in support of denying the appeal.
- Rebecca O'Brien spoke in support of denying the appeal.
- Karina Steib spoke in support of denying the appeal.

Mayor Combs closed the public hearing.

The City Council received clarification on California Department of Alcoholic Beverage Control (ABC) license requirements for gas stations in Menlo Park.

The City Council discussed the appellant's presentation and whether there was a public convenience or necessity of permitting beer and wine sales and 24-hour operations at the site.

**ACTION:** Motion and second (Wolosin/ Combs), to adopt Resolution No. 6658 making the necessary findings and denying the appeal and upholding the Planning Commission's denial of a use permit request to allow the sale of beer and wine at an existing service station convenience store for off-premises consumption every day from 6 a.m. to 2 a.m. the following day, and to operate the service station and convenience store 24 hours a day, passed 4-0 (Mueller absent).

## I. Informational Items

- J1. City Council agenda topics: September 2021 (Staff Report #21-159-CC)
- J2. Request for information on the former redevelopment agency, also known as the Community Development Agency (Staff Report #21-160-CC)

- Pam Jones requested clarification on the July 2018 – July 2029 payment schedule.

The City Council requested clarification on the dissolution of redevelopment agency.

- J3. Update on housing element update community engagement and outreach efforts (Staff Report #21-161-CC)

- Kevin Chan provided options to increase public engagement.

- J4. Recreation scholarship pilot program update (Staff Report #21-162-CC)

## J. City Manager's Report

None.

**K. City Councilmember Reports**

Mayor Combs reported on an email from City Councilmember Mueller requesting agendaing a draft ordinance prohibiting the use of park lands for any other usage.

City Councilmember Taylor reported out on Menlo Park Community Campus subcommittee meeting.

Vice Mayor Nash reported out on the Peninsula Clean Energy meeting.

**L. Adjournment**

Mayor Combs adjourned the meeting at 11:33 p.m.

Judi A. Herren, City Clerk

## NOVEL CORONAVIRUS, COVID-19, EMERGENCY ADVISORY NOTICE

On March 19, 2020, the Governor ordered a statewide stay-at-home order calling on all individuals living in the State of California to stay at home or at their place of residence to slow the spread of the COVID-19 virus. Additionally, the Governor has temporarily suspended certain requirements of the Brown Act. For the duration of the shelter in place order, the following public meeting protocols will apply.

Teleconference meeting: All members of the City Council, city staff, applicants, and members of the public will be participating by teleconference. To promote social distancing while allowing essential governmental functions to continue, the Governor has temporarily waived portions of the open meetings act and rules pertaining to teleconference meetings. This meeting is conducted in compliance with the Governor Executive Order N-25-20 issued March 12, 2020, and supplemental Executive Order N-29-20 issued March 17, 2020.

- How to participate in the closed session and regular meeting
  - Submit a written comment online up to 1-hour before the meeting start time:  
[menlopark.org/publiccommentAugust31](http://menlopark.org/publiccommentAugust31) \*
  - Access the meeting real-time online at:  
[Zoom.us/join](https://zoom.us/join) – Meeting ID 998 8073 4930
  - Access the meeting real-time via telephone at:  
(669) 900-6833  
Meeting ID 998 8073 4930  
Press \*9 to raise hand to speak  
Written public comments are accepted up to 1-hour before the meeting start time. Written messages are provided to the City Council at the appropriate time in their meeting.
  
- Watch meeting:
  - Cable television subscriber in Menlo Park, East Palo Alto, Atherton, and Palo Alto:  
Channel 26
  - Online:  
[menlopark.org/streaming](http://menlopark.org/streaming)

Note: City Council closed sessions are not broadcast online or on television and public participation is limited to the beginning of closed session.

Subject to Change: Given the current public health emergency and the rapidly evolving federal, state, county and local orders, the format of this meeting may be altered or the meeting may be canceled. You may check on the status of the meeting by visiting the City’s website [www.menlopark.org](http://www.menlopark.org). The instructions for logging on to the webinar and/or the access code is subject to change. If you have difficulty accessing the webinar, please check the latest online edition of the posted agenda for updated information ([menlopark.org/agenda](http://menlopark.org/agenda)).







**SPECIAL MEETING AGENDA**

**Date:** 9/21/2021  
**Time:** 5:00 p.m.  
**Location:** Zoom

**STAFF REPORT RELEASE NOTICE**

The Staff Report No. 21-179-CC for Approve and appropriate \$10,000 for seed money to support the newly formed Menlo Park Sister Cities Association and ongoing sister cities program will be available on September 17, 2021.

Members of the public can view electronic agendas and staff reports by accessing the City website at [menlopark.org/agenda](http://menlopark.org/agenda) and can receive email notification of agenda and staff report postings by subscribing to the "Notify Me" service at [menlopark.org/notifyme](http://menlopark.org/notifyme). Agendas and staff reports may also be obtained by contacting the City Clerk's Office at 650-330-6620. (Posted 9/16/2021.)



**STAFF REPORT – CONTINUED FROM 8/31/2021**

**City Council**

**Meeting Date:** ~~8/31/2021~~ 9/21/2021

**Staff Report Number:** 21-163-CC

**Consent Calendar:** **Adopt Resolution No. 6654 approving the funding agreement with Hibiscus Properties for the construction of raised median islands on Chilco Street and authorizing the city manager to execute the funding agreement**

**Recommendation**

Staff recommends the City Council adopt Resolution No. 6654 (Attachment A) approving the funding agreement (Attachment B) with Hibiscus Properties for the construction of raised median islands on Chilco Street and authorizing the city manager to execute the funding agreement.

**Policy Issues**

City Council authorization of a funding agreement is required as the agreement amount exceeds the city manager's expenditure authority.

**Background**

The Facebook campus expansion project was approved November 1, 2016, and includes two new office buildings (Buildings 21 and 22) and a limited service hotel. The project also includes approximately two acres of publicly accessible open space and a bicycle/pedestrian bridge over Bayfront Expressway. Applicable entitlements and agreements for the project included an amended and restated conditional development permit, a development agreement, rezoning, a zoning ordinance text amendment, heritage tree removal permits, and a below market rate (BMR) housing agreement. The development agreement and associated conditional development permit were amended in November 2017 as part of applicant-initiated revisions to the approved campus expansion project.

As part of the development agreement, per sections 7.1.6 and 7.1.7, Facebook agreed to design and construct streetscape improvements along Chilco Street between Bayfront Expressway and Hamilton Avenue. The improvements include roadway, intersection, pedestrian, bicycle, landscaping and stormwater improvements. The addition of raised median islands as shown in Attachment C is a desired improvement that is not required per the development agreement. The median islands would help to reduce speed and increase safety along Chilco Street as described further in the following section.

**Analysis**

In consultation with the Menlo Park Fire Protection District (MPFPD) during the Chilco Street streetscape design phase, it was determined that a minimum street width of 28.5 feet is needed for a fire truck to navigate the street during commute peak hours. This width would mean each travel lane is more than 14 feet wide and is anticipated to encourage higher than desired travel speeds. As a result, a center median

was considered to narrow the lanes in an effort to slow traffic while still providing clear travel path for fire vehicles. A total of five median islands are proposed along the section of Chilco Street that parallels the Dumbarton Rail tracks, where speeding tends to occur. The islands would be 6.5 feet wide and would separate the two 11-foot travel lanes. The islands would have a concrete finish and rolled curbs, which would allow emergency vehicles to drive on or over them if needed. The MPFPD is supportive of the project and has reviewed the design plans.

The proposed median island improvements are estimated to cost \$335,650. This cost assumes that the work would be consolidated into an approximately two-week timeframe, during which time Chilco Street would be fully closed to ~~the~~ traffic from Constitution Drive to Terminal Avenue. Access to entrances and driveways would be permitted. The approved detour plan is included as Attachment D. [A second option was considered in which the medians would be constructed one at a time over 5 consecutive weekends. A full road closure would be required from Thursday morning to Monday morning each week, and the road would be fully open from Monday morning through Wednesday evening. However, since Willow Road is scheduled for paving during overlapping weekends, this option is not recommended due to the added traffic impacts. Because of the increased number of total working days and additional costs associated with weekend work, this option is estimated to cost \\$495,000. Under a third option, Chilco Street would remain open to one-way traffic for the duration of construction, 4 weeks, and the medians would be constructed one half at a time. The cost for this option is approximately \\$605,650. Without the full road closure, only half of the medians could be built at a time, thus extending the construction time to approximately four weeks and resulting in an additional cost of approximately \\$270,000.](#)

**Funding agreement**

The City will reimburse the project developer 100 percent of the cost of the median island improvements. The funding agreement is included as Attachment B.

**Next steps**

If authorization of the funding agreement is approved by the City Council, the agreement will be executed and outreach regarding the traffic detour would occur immediately. Construction would begin approximately the week of [October 5](#)~~[September 13](#)~~, 2021.

**Impact on City Resources**

Funding for the median island improvements is included in the capital improvement plan (CIP) under the Chilco streetscape and sidewalk installation project. The project is funded through the building construction street impact fee. The available fund balance is \$926,695. The total project construction budget, including contingencies, inspection, and contract administration is \$389,358. The estimated construction cost would not exceed this amount, per Table 1.

Table 1: Construction budget	
Item	Amount
Project construction bid	\$335,650
Inspection services	\$3,360
Construction contingency (15%) (held by City)	\$50,348
<b>Total construction cost</b>	<b>\$389,358</b>

Upon completion of construction, if funds remain, they will be returned to the CIP budget.

**Public Notice**

Public notification was achieved by posting the agenda, with the agenda items being listed, at least 72 hours prior to the meeting.

**Attachments**

- A. Resolution No. 6654
- B. Funding agreement
- C. Median island exhibit
- D. Detour plan

Report prepared by:  
Theresa Avedian, Senior Civil Engineer

Report reviewed by:  
Karen Pachmayer, Interim Assistant Public Works Director

**RESOLUTION NO. 6654**

**RESOLUTION OF THE CITY COUNCIL OF THE CITY OF MENLO PARK  
APPROVING THE FUNDING AGREEMENT WITH HIBISCUS PROPERTIES,  
LLC FOR CONSTRUCTION OF MEDIAN ISLANDS ALONG CHILCO STREET  
AND AUTHORIZING THE CITY MANAGER TO EXECUTE THE FUNDING  
AGREEMENT**

WHEREAS, the Owner owns real property commonly known as 1 Facebook Way, Menlo Park, California; and

WHEREAS, the 1 Facebook Way project (the “Campus Expansion” project) is currently under construction; and

WHEREAS, pursuant to sections 7.1.6 and 7.1.7 of the Development Agreement, Owner is required to complete certain capital improvements on Chilco Street (the “DA Chilco Street Improvements”); and

WHEREAS, the City believes that the addition of raised median islands (the “Chilco Street Median Islands”) as specified in Exhibit A to the Funding Agreement would reduce vehicle speed and improve safety along Chilco Street. The addition of the Chilco Street Median Islands is not required by the Development Agreement and will be fully funded by the City; and

WHEREAS, the Parties recognize that it would be more efficient, less disruptive, and more cost-effective for the Owner to construct the Chilco Street Median Islands at the same time as the DA Chilco Street Improvements, in consultation with the City, subject to all the terms and conditions set forth in the Funding Agreement.

NOW, THEREFORE, BE IT RESOLVED by the City Council of the City of Menlo Park that the City Council does hereby approve the Funding Agreement with Hibiscus Properties, LLC for construction of the Chilco Street Median Islands; and

BE IT FURTHER RESOLVED that said City Council authorizes the City Manager to execute the Funding Agreement.

//  
//  
//  
//  
//  
//  
//  
//  
//

I, Judi A. Herren, City Clerk of Menlo Park, do hereby certify that the above and foregoing City Council Resolution was duly and regularly passed and adopted at a meeting by said City Council on the thirty-first day of August, 2021, by the following votes:

AYES:

NOES:

ABSENT:

ABSTAIN:

IN WITNESS WHEREOF, I have hereunto set my hand and affixed the Official Seal of said City on this thirty-first day of August, 2021.

---

Judi A. Herren, City Clerk

# FUNDING AGREEMENT

City Manager's Office  
701 Laurel St., Menlo Park, CA 94025  
tel 650-330-6620



This Funding Agreement ("Agreement") is made this day of \_\_\_\_\_, ("Execution Date") by and between the City of Menlo Park ("City") and Hibiscus Properties, LLC, a Delaware limited liability company ("Owner"), each of which is referred to herein individually as "Party" and jointly as "Parties."

## RECITALS:

WHEREAS, the Owner owns real property commonly known as 1 Facebook Way, Menlo Park, California ("Property"); and

WHEREAS, a project to expand the Property (the "Campus Expansion" project) is currently under construction; and

WHEREAS, pursuant to sections 7.1.6 and 7.1.7 of the Development Agreement between the Parties (as amended, the "Development Agreement") and relating to the Campus Expansion project, Owner is required to complete certain capital improvements to Chilco Street (the "DA Chilco Street Improvements"); and

WHEREAS, the City believes that the addition of raised median islands as specified in Exhibit 1 to this Agreement (the "Chilco Street Median Islands") would reduce vehicle speed and improve safety along Chilco Street. The addition of the Chilco Street Median Islands is not required by the Development Agreement and will be fully funded by the City; and

WHEREAS, the Parties recognize that it would be more efficient, less disruptive, and more cost-effective for the Owner to construct the Chilco Street Median Islands at the same time that Owner constructs the DA Chilco Street Improvements, subject to all the terms and conditions set forth in this Agreement.

NOW, THEREFORE, the Parties agree as follows:

## SECTION 1: SCOPE OF WORK AND REPORTING

1.1 Owner shall be responsible for the following Scope of Work:

- 1.1.1 Owner shall hire a consultant for designing the Chilco Street Median Islands, hire a licensed Contractor to perform the work to complete the Chilco Street Median Islands and pay for all such work (subject to the City's reimbursement obligation set forth below).
- 1.1.2 Owner shall be responsible for procuring and handling all material required for the completion of the Chilco Street Median Islands.
- 1.1.3 Owner shall be responsible for construction of the Chilco Street Median Islands in accordance with the approved project plans to the reasonable satisfaction of the Public Works Director.
- 1.1.4 Owner will provide the City a copy of the construction contract for the Chilco Street Median Islands (the "Construction Contract"), and Owner will obtain the City's prior written approval before entering into the Construction Contract. Owner will not enter into change orders relating to the Chilco Street Median Islands without the City's prior written approval. Owner shall deliver copies of all invoices related to the Chilco Street Median Islands to the City.
- 1.1.5 Owner acknowledges that public funds are being used to pay for the Chilco Street Median Islands and shall ensure that any construction work related to the Chilco Street Median Islands includes payment of prevailing wages as defined and required by law.

## **SECTION 2: ACCESS TO RECORDS AND RECORD RETENTION**

2.1 At all reasonable times, Owner will permit, upon request, the City to access all reports, designs, drawings, plans, specifications, schedules and other materials prepared, or in the process of being prepared, for the Chilco Street Median Islands by Owner or any contractor or consultant of Owner. Owner will provide copies of any documents and Autocad drawings described in this Section to the City upon request and the City may use them for construction of the Chilco Street Median Islands without further approval from Owner. Owner will assist the City with obtaining any third party consents required for the City to use any documents or Autocad drawings described in this Section. Owner and the City will retain all records pertaining to the work for at least three years after completion of the Work.

## **SECTION 3: FUNDING AND PAYMENT**

3.1 Upon completion of the Chilco Street Median Islands and the City's receipt of invoices showing amounts paid by Owner for the Chilco Street Median Islands work, the City shall pay Owner for all costs that Owner incurred with respect to the Chilco Street Median Islands, provided however, that the City's reimbursement obligation shall not exceed the estimated cost to construct the Chilco Street Median Islands plus a 15% contingency. The Chilco Street Median Islands are estimated to cost \$335,650. Therefore, the City's reimbursement obligation shall not exceed \$385,998.

## **SECTION 4: TERM**

4.1 This Agreement shall commence upon the Effective Date. Prior to the execution of the Construction Contract, this Agreement may be terminated by either Party in writing with sixty (60) days advance written notice. This Agreement shall end upon completion of the Chilco Street Median Islands unless terminated earlier.

## **SECTION 5: INDEMNIFICATION AND INSURANCE**

5.1 Owner agrees, while engaged in the work provided for in this Agreement, to place and maintain suitable safeguards sufficient to prevent injury to any persons and to indemnify, defend and save harmless the City, its officers, representatives, and employees from and against any and all claims for loss, injury or damage resulting from the prosecution of said work except to the extent any claim arises out of the sole negligence or willful misconduct of the City. To the full extent required by applicable federal and state law, Owner and its contractors and agents shall comply with California Labor Code Section 1720 et seq. and the regulations adopted pursuant thereto, and shall be solely responsible for carrying out the requirements of such provisions. Owner shall indemnify, defend and hold the City and its elected and appointed officers, officials, employees, agents, consultants, and contractors harmless from and against all liability, loss, cost, expense (including without limitation attorneys' fees and costs of litigation), claim, demand, action, suit, judicial or administrative proceeding, penalty, deficiency, fine, order, and damage which directly or indirectly, in whole or in part, are caused by, arise in connection with, result from, relate to, or are alleged to be caused by, arise in connection with, or relate to, the payment or requirement of payment of prevailing wages.

5.2 City agrees, while engaged in the work provided for in this Agreement, to place and maintain suitable safeguards sufficient to prevent injury to any persons and to indemnify, defend and save harmless Owner, its officers, representatives, and employees from and against any and all claims for loss, injury or damage resulting from the prosecution of said work except to the extent any claim arises out of the negligence or willful misconduct of Owner.



**SECTION 6: MISCELLANEOUS**

6.1 Notices. All notices required or permitted to be given under this Agreement must be in writing and mailed postage prepaid by certified or registered mail, return receipt requested, or by personal delivery or overnight courier to the appropriate address indicated below or at such other place(s) that either Party may designate in written notice to the other. Notices are deemed received upon delivery if personally served, one day after mailing if delivered via overnight courier, or two days after mailing if mailed as provided above.

To Owner:                   Hibiscus Properties, LLC  
                                   c/o Facebook, Inc.  
                                   Attn: Facilities  
                                   1 Hacker Way  
                                   Menlo Park, CA 94025

Cc:                            Facebook, Inc.  
                                   Attn: Real Estate Counsel  
                                   1 Hacker Way  
                                   Menlo Park, CA 94025

To the City:                City of Menlo Park,  
                                   Attn: Public Works Director  
                                   701 Laurel Street  
                                   Menlo Park, California 94025-3409

Cc:                            City of Menlo Park  
                                   Attn: City Attorney  
                                   Burke, Williams & Sorensen, LLP  
                                   181 Third Street, Suite 200  
                                   San Rafael, CA 9490

6.2 No Waiver. No waiver of any default or breach of any covenant of this Agreement by either Party will be implied from any omission by either Party to take action on account of such default if such default persists or is repeated. Express waivers are limited in scope and duration to their express provisions. Consent to one action does not imply consent to any future action.

6.3 Assignment. The Parties are prohibited from assigning, transferring or otherwise substituting their interests or obligations under this Agreement without the written consent of all other Parties, provided however, Owner shall have the right to assign this Agreement to an affiliated entity of Owner that is the owner of the Property without the prior approval or consent of the City.

6.4 Governing Law. This Agreement is governed by the laws of the State of California as applied to contracts that are made and performed entirely in California.

6.5 Compliance with Laws. In performance of this Agreement, the Parties must comply with all applicable Federal, State and local laws, regulations and ordinances.

6.6 Modifications. This Agreement may only be modified in a writing executed by both Parties.

6.7 Relationship of the Parties. It is understood that this Agreement does not create the relationship of agent, servant, employee, partnership, joint venture or association between the parties.

6.8 Intentionally Deleted.

6.9 Warranty of Authority to Execute Agreement. Each Party to this Agreement represents and warrants that each person whose signature appears hereon is authorized and has the full authority to execute this Agreement on

behalf of the entity that is a Party to this Agreement.

6.10 Severability. If any portion of this Agreement, or the application thereof is held by a court of competent jurisdiction to be invalid, void or unenforceable, the remaining portions of this Agreement, or the application thereof, will remain in full force and effect.

6.11 Counterparts. This Agreement may be executed in counterparts.

6.12 Entire Agreement. This Agreement constitutes the entire agreement between the parties pertaining to its subject matter and supersedes any prior or contemporaneous written or oral agreement between the parties on the same subject.

(Signatures on following page)

IN WITNESS WHEREOF, the Parties have hereunder subscribed their names the day and year indicated below.

Hibiscus Properties, LLC  
a Delaware Limited Liability Company

By: \_\_\_\_\_

Name:

Title:

CITY OF MENLO PARK, a municipal corporation

**APPROVED AS TO FORM:**

\_\_\_\_\_  
Nira F. Doherty, City Attorney

\_\_\_\_\_  
Date

**CITY OF MENLO PARK:**

\_\_\_\_\_  
Starla Jerome-Robinson, City Manager

\_\_\_\_\_  
Date

**ATTEST:**

\_\_\_\_\_  
Judi A. Herren, City Clerk

\_\_\_\_\_  
Date

Attachments: Exhibit 1, Improvement Plan

**Exhibit 1  
(Improvement Plan)**

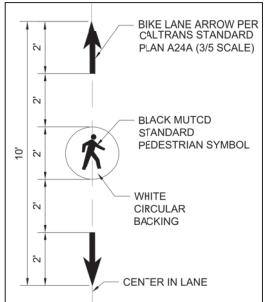

PEDESTRIAN MARKING  
NOT TO SCALE

1

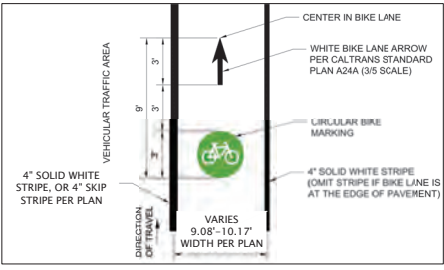

BIKE LANE MARKING-TYPE I  
NOT TO SCALE

2

LINE TABLE		CURVE TABLE				
LINE #	DIRECTION	LENGTH	CURVE #	RADIUS	DELTA	LENGTH
L1	N74°48'00\"/>	50.96'	C1	10.00'	88°28'29\"/>	15.44'
L2	N13°38'29\"/>	19.58'	C2	18.00'	99°13'55\"/>	31.17'
L3	N13°38'29\"/>	7.05'	C3	298.00'	5°49'51\"/>	30.33'
L4	N76°21'31\"/>	201.93'	C4	342.00'	22°54'59\"/>	136.79'
L5	N77°00'18\"/>	32.61'	C5	551.00'	14°06'39\"/>	136.79'
L6	N74°48'00\"/>	270.83'	C6	1408.00'	6°15'26\"/>	153.77'
L7	N74°48'00\"/>	404.58'	C9	80.00'	15°03'37\"/>	21.03'
L8	S15°12'00\"/>	1.19'	C10	99.50'	15°06'12\"/>	28.23'
L9	N76°21'31\"/>	201.96'	C11	496.50'	6°06'07\"/>	52.88'
L10	S15°12'00\"/>	1.23'	C12	1388.50'	7°07'06\"/>	172.51'
L11	S74°48'00\"/>	218.68'	C13	304.00'	2°06'43\"/>	11.20'
L12	N74°48'00\"/>	66.47'	C14	336.00'	22°54'59\"/>	134.39'
L13	N74°39'45\"/>	38.60'	C15	557.00'	7°25'10\"/>	72.13'
L14	N73°44'44\"/>	30.24'	C17	3.00'	88°42'59\"/>	4.65'
L15	S15°12'00\"/>	2.00'	C18	3.00'	84°26'25\"/>	4.42'
L16	N73°44'44\"/>	34.93'				
L17	S74°48'00\"/>	16.54'				
L18	N74°48'00\"/>	216.07'				
L19	S15°12'00\"/>	3.98'				
L20	S15°12'00\"/>	4.00'				
L21	N76°19'44\"/>	224.07'				
L22	N76°05'01\"/>	24.76'				

- KEYNOTES**
- 36" KEED CURB AND GUTTER PER DETAIL 3/C1.1
  - CURB AND GUTTER WITH MEDIAN PER DETAIL 10/C1.1
  - 42" KEED CURB AND GUTTER PER DETAIL 4/C1.1
  - 3" TRANSITION OF CURB FROM 6" HIGH TO 0" HIGH
  - FLUSH CURB PER DETAIL 8/C1.1
  - 8" CURB WITH GUTTER ON BOTH SIDES PER DETAIL 9/C1.1
  - LINEAR BORDERTON CURB AND GUTTER AND CUTOFF WALL PER DETAIL 4/C1.2
  - CURB AND GUTTER PER DETAIL 11/C1.1
  - MEDIAN ROLLED CURB AND GUTTER PER DETAIL 6/C1.2

**PAVING LEGEND**

	ASPHALT VEHICULAR PAVEMENT	12" AC DEEP LEFT
	ASPHALT BIKE PLANE PAVEMENT	3" AC OVER 8" CLASS II AB OVER 16" NON-EXPANSIVE FILL
	CONCRETE VEHICULAR PAVEMENT	8" FCC OVER 8" CLASS II AB ON 5CM F.C. SUBGRADE WITH #4 BAR PER D.C. & CONTRACTOR UNLESS 12" D.C.
	CONCRETE SIDEWALK	4" FCC OVER 24" NON-EXPANSIVE FILL
	GRIND AND OVERLAY	GRIND DOWN A MINIMUM OF 1" AND OVERLAY A MINIMUM OF 1.5"

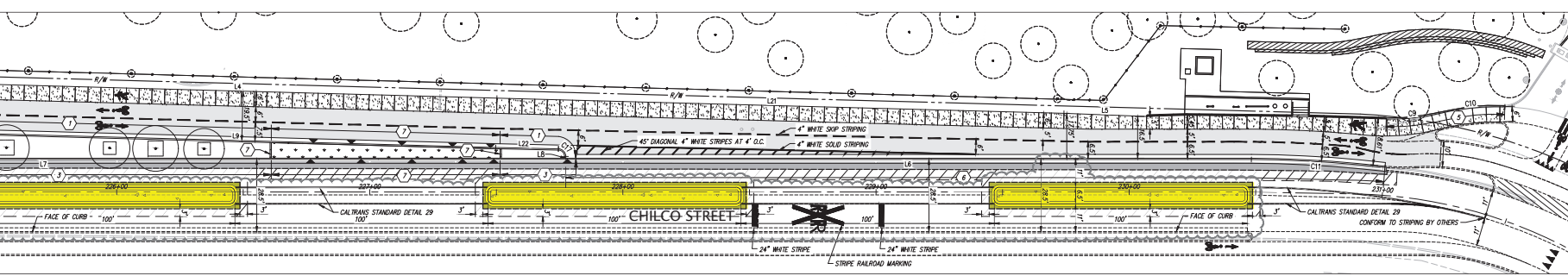
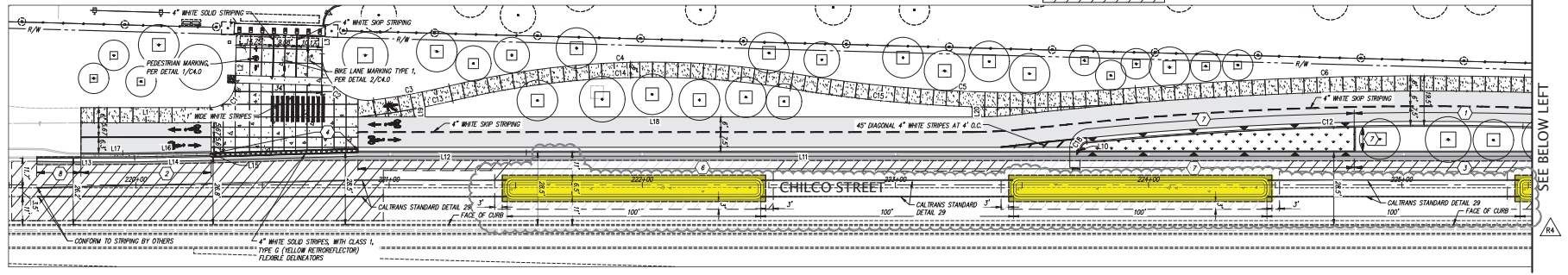
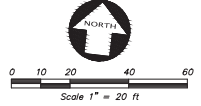

DATE: 08/11/2020	APPROVED:	11/22/19 PERMIT SUBMITTAL
SCALE: AS SHOWN		03/31/20 PERMIT R1
DRAWN BY: NLH		06/08/20 PERMIT R2
DRAWING NAME: A15571-7	EMAD Y. BARIEDDINE, P.E. RCE #8112 EXP 9/30/2021	07/02/20 PERMIT R3
DESIGNED BY: NLH	KIER & WRIGHT CIVIL ENGINEERS & SURVEYORS, INC.	07/14/20 PERMIT APPROVAL
CHECKED BY: EYS	08/11/2020	08/11/20 PERMIT R4
SURVEYED BY:	DATE	NO. BY DATE REVISIONS

**KIER+WRIGHT**  
 2850 Collier Canyon Road  
 Livermore, California 94551  
 Phone (925) 245-8788  
 www.kierwright.com

**CURB, STRIPING, & PAVING PLAN  
 STREET IMPROVEMENT PLANS  
 CHILCO STREET**

SHEET  
**C40**  
 OF 64 SHEETS  
 PROJ. NAME  
**CHILCO STREET**

**"TRAFFIC CONTROL GENERAL NOTES"**

1. ALL TRAFFIC CONTROL DEVICES AND THEIR PLACEMENT SHALL CONFORM TO THE REQUIREMENTS OF THE CALIFORNIA MANUAL ON UNIFORM TRAFFIC CONTROL DEVICES (CA-MUTCD), 2014 EDITION -REVISION 4.
2. FIELD CHANGES, OTHER THAN MINOR ADJUSTMENTS APPROVED BY THE CITY'S INSPECTOR OR AUTHORIZED AGENT, MUST BE AUTHORIZED IN WRITING BY CITY TRAFFIC ENGINEER.
3. PLAN IMPLEMENTATION AND DEVICES PLACEMENT SHALL BE PERFORMED BY CERTIFIED TRAINED PERSONNEL.
4. ALL FLAGGERS SHALL BE CERTIFIED AS REQUIRED BY CAL OSHA.
5. TRAFFIC CONTROL DEVICES MUST BE MONITORED AND MAINTAINED BY CERTIFIED TRAFFIC CONTROLLERS OR THE CONTRACTOR AT ALL TIMES.
6. TEMPORARY NO PARKING SIGNS MUST BE PLACED 72 HOURS IN ADVANCE OF SCHEDULED CLOSURE.
7. CONTRACTOR SHALL MAINTAIN ACCESS TO ALL DRIVEWAYS, RESIDENCES AND BUSINESS AT ALL TIMES UNLESS OTHERWISE NOTED. CONTRACTOR SHALL NOTIFY ALL AFFECTED RESIDENCES AND BUSINESSES 72 HOURS IN ADVANCE PRIOR TO CLOSURE OF A DRIVEWAY OR ACCESS.
8. THE CONTRACTOR SHALL PROVIDE SAFE PEDESTIAN ACCESS THROUGH THE PROJECT SITE AT ALL TIMES. ONLY ONE STREET & SIDEWALK WILL BE CLOSED AT A TIME. PEDESTRIAN & DISABLED ACCESS TO BE MAINTAINED PER THE LATEST 2014 CA MUTCD STANDARD.
9. ALL TRAFFIC CONTROL DEVICES WILL BE PLACED THROUGHOUT THE DURATION OF PROJECT COMPLETION.
10. ANY TRAFFIC CONTROL DEVICES TO REMAIN IN PLACE OVERNIGHT SHALL BE LIGHTED.
11. ANY TRAFFIC CONTROL DEVICES SHALL NOT BE PLACED ON PRIVATE PROPERTY.
12. ANY CHANGES TO THE TRAFFIC CONTROL PLAN(S) WILL NEED TO BE APPROVED BY THE CITY OF TRAFFIC ENGINEER OR INSPECTOR.
13. THE CONTRACTOR SHALL REASONABLY ACCOMMODATE A PROPERTY OWNER'S REQUEST TO CROSS THE WORK ZONE TO ENTER OR LEAVE THEIR PROPERTY AT ALL TIMES.
14. THE ADVANCE NOTIFICATION SIGNS SHALL BE SUFFICIENT SIZE TO ACCOMMODATE THE MESSAGE. SIGN AND CHANNELIZING DEVICES MUST BE RETRO REFLECTIVE OR ILLUMINATED FOR THE NIGHT. MINIMUM VISIBILITY 1000FT.
15. TRAFFIC SHALL BE UNDER FLAGGING CONTROL WHEN ANY CONSTRUCTION OPERATION IS OCCURRING IN THE ROADWAY.
16. THE CONTRACTOR SHALL PROVIDE EMERGENCY ACCESS TO THE JOB SITE AND TO ANY ADJACENT PRIVATE PROPERTY AT ALL TIMES.



**845 Reed St. Santa Clara, CA. 95050 (408) 436-1127**

Requested By	
Name: Alexis Susnow	Company: JJ Albanese
Direct Line: 408-200-6257	Address: 851 Martion Ave, Santa Clara
Mobile Phone:	
Email: asusnow@jjalbanese.com	
PO#:	JOB #: 20-1041

Project Information	Plan & Revision Dates
Name:	Plan Date: 7-13-21
Location: Chilco St, Menlo Park	Rev Date: 8-16-21
	Rev Date:
Description: Road Closure	
	Total Plan Pages: 2 <span style="float: right;">not including cover page</span>

Plans Prepared By: Wincart Ware - Email: WincartW@dmtraffic.com

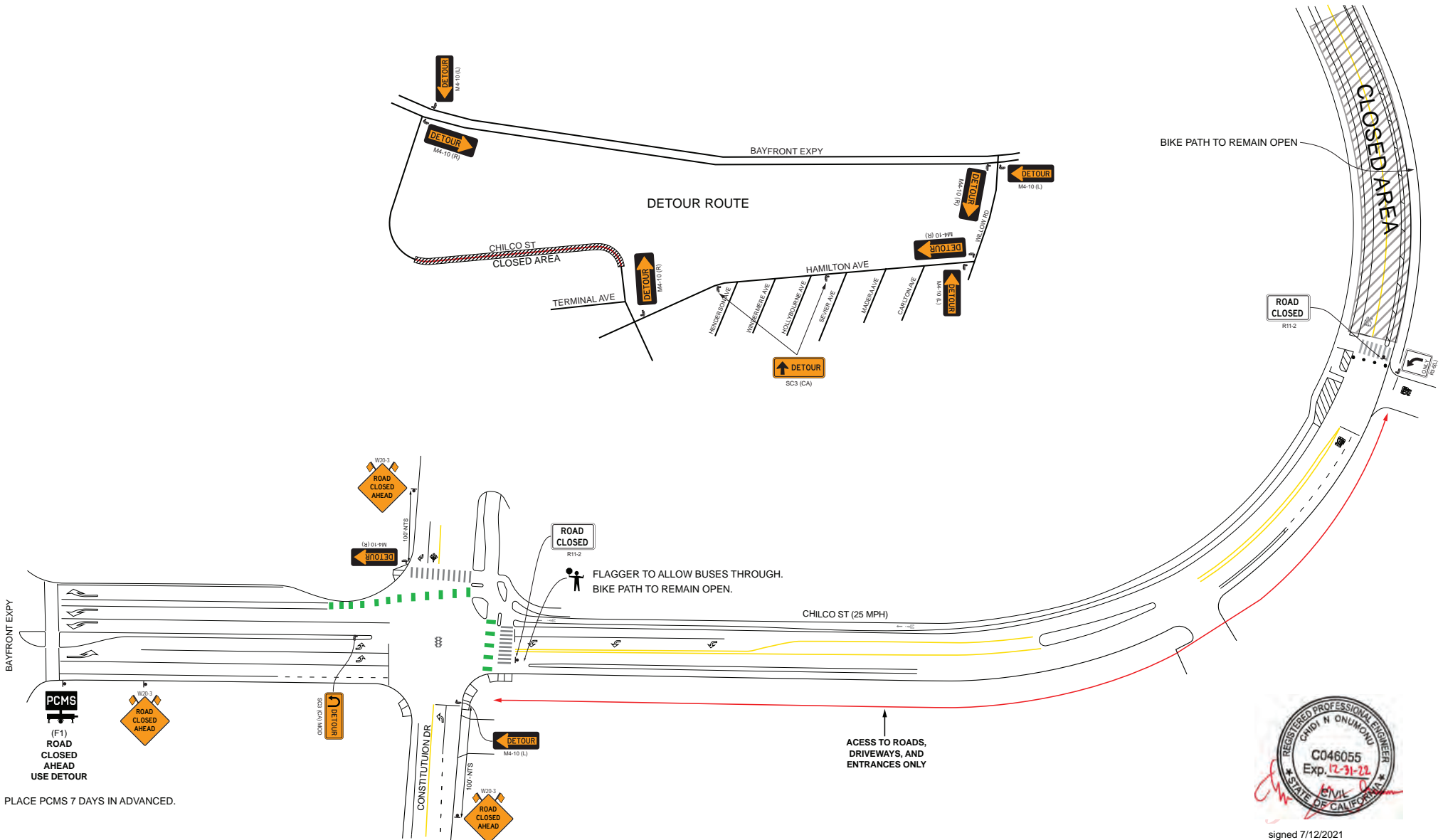

signed 7/12/2021

PLACE PCMS 7 DAYS IN ADVANCED.

ALL TRAFFIC CONTROL DEVICES AND THEIR PLACEMENT SHALL CONFORM TO THE REQUIREMENTS OF THE CALIFORNIA MANUAL ON UNIFORM TRAFFIC CONTROL DEVICES (CA-MUTCD), LATEST EDITION

<p>845 Reed St. Santa Clara, Ca 95051 408-436-1127</p>	<b>LEGEND:</b> High Visibility Sign Cone/Delineation Work Area Flagger Type I barricade w/ sign Type III barricade w/ sign Directional Travel Flashing Arrowboard Message Board (PCMS) Flashing Beacon Temp No Parking Signs Type I barricade w/o sign Type II barricade w/o sign Temporary ADA Ramp Work Vehicle	<b>NOTES:</b> <ul style="list-style-type: none"> <li>LOCATIONS OF ADVANCE WARNING SIGNS ARE APPROXIMATE. EXACT LOCATIONS TO BE DETERMINED IN THE FIELD.</li> <li>ALL ADVANCED WARNING SIGNS SHALL BE EQUIPPED WITH 2 (18" ORANGE FLAGS)</li> <li>TEMPORARY NO PARKING SIGNS SHALL BE PLACED A MIN OF 72 HRS PRIOR OF WORK. SIGNS SHALL STATE DATE(S)/HOURS OF RESTRICTION. NOTIFY POLICE DEPT ONCE SIGNS ARE POSTED.</li> <li>CERTIFIED TRAFFIC CONTROL WORKERS SHALL HAVE TYPE II VESTS, WORK SHOES, HARD HATS &amp; RADIO.</li> <li>ALL DEVICES SHALL BE REMOVED WHEN NO LONGER REQUIRED.</li> <li>ROADWAY SHALL NOT BE OPENED UNTIL SAFE FOR PUBLIC USE.</li> <li>ALL OPEN TRENCHES MUST BE PLATED OR BACKFILLED PRIOR TO PUBLIC USAGE.</li> <li>ALL DRIVEWAYS TO REMAIN ACCESSIBLE AT ALL TIMES.</li> </ul>	<b>CONTRACTOR:</b> JJ ALBANESE	<b>REV LOG</b> 1      8-16-21	<b>DATE</b> 8-16-21	<b>DRAWING BY:</b> 		<b>TEMP TCP FOR:</b>  <b>ROAD CLOSURE</b>
			<b>LOCATION:</b> CHILCO ST, MENLO PARK	<b>SUBMITTAL DATE:</b> 7-12-21	<b>TCP SHEET</b> 1 OF 2	NOT TO SCALE		

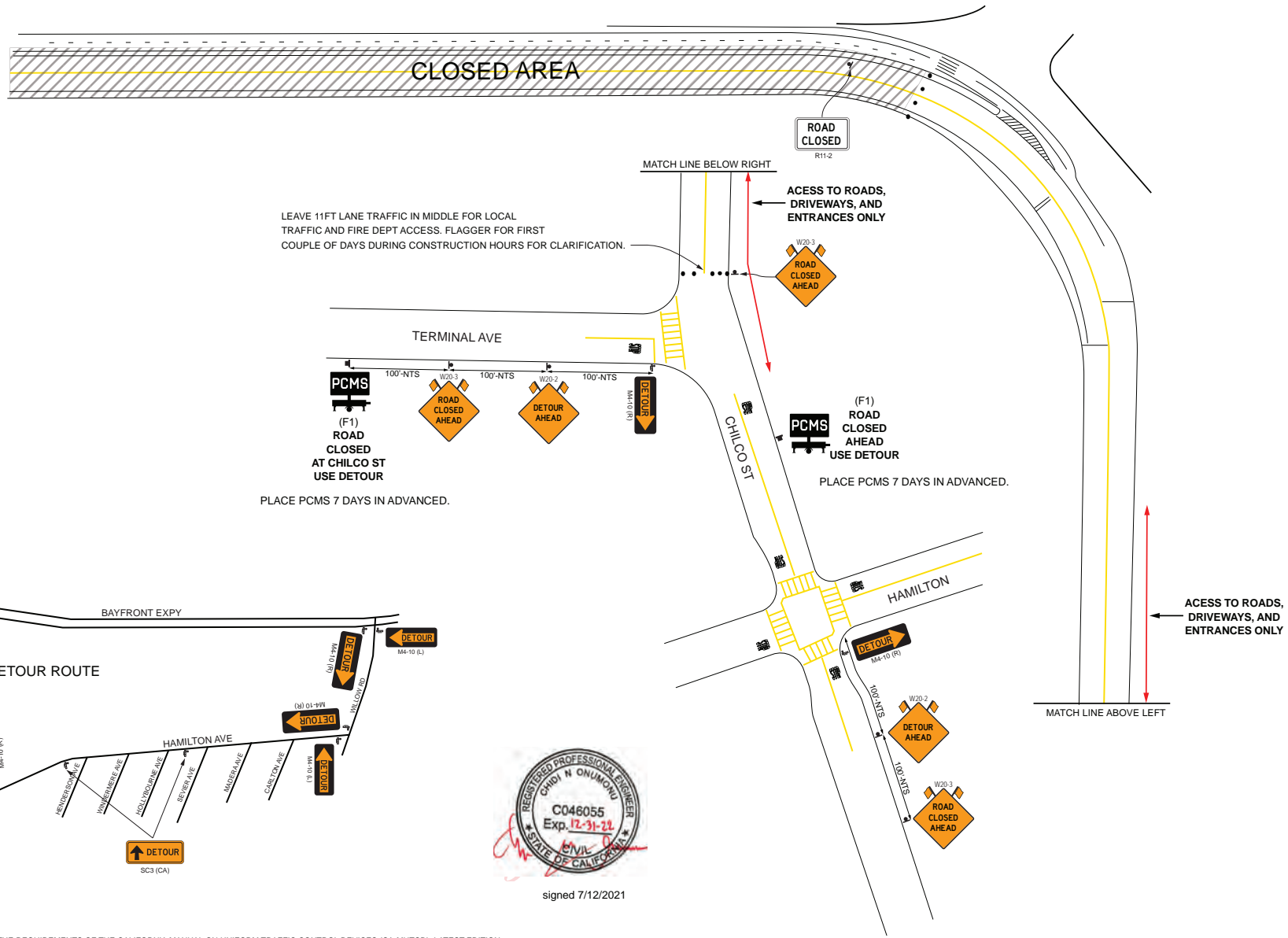

ALL TRAFFIC CONTROL DEVICES AND THEIR PLACEMENT SHALL CONFORM TO THE REQUIREMENTS OF THE CALIFORNIA MANUAL ON UNIFORM TRAFFIC CONTROL DEVICES (CA-MUTCD), LATEST EDITION

LEGEND:	
	High Visibility Sign
	Cones/Delineation
	Work Area
	Flagger
	Type I barricade w/ sign
	Type III barricade w/ sign
	Directional Travel
	Flashing Arrowboard
	Message Board (PCMS)
	Flashing Beacon
	Temp No Parking Signs
	Type I barricade w/o sign
	Type III barricade w/o sign
	Temporary ADA Ramp
	Work Vehicle

**NOTES:**

- LOCATIONS OF ADVANCE WARNING SIGNS ARE APPROXIMATE. EXACT LOCATIONS TO BE DETERMINED IN THE FIELD.
- ALL ADVANCED WARNING SIGNS SHALL BE EQUIPPED WITH 2 (1" ORANGE FLAGS)
- TEMPORARY NO PARKING SIGNS SHALL BE PLACED A MIN OF 72 HRS PRIOR OF WORK. SIGNS SHALL STATE DATE(S)/HOURS OF RESTRICTION. NOTIFY POLICE DEPT ONCE SIGNS ARE POSTED.
- CERTIFIED TRAFFIC CONTROL WORKERS SHALL HAVE TYPE II VESTS, WORK SHOES, HARD HATS & RADIO.
- ALL DEVICES SHALL BE REMOVED WHEN NO LONGER REQUIRED.
- ROADWAY SHALL NOT BE OPENED UNTIL SAFE FOR PUBLIC USE.
- ALL OPEN TRENCHES MUST BE PLATED OR BACKFILLED PRIOR TO PUBLIC USAGE.
- ALL DRIVEWAYS TO REMAIN ACCESSIBLE AT ALL TIMES.

**CONTRACTOR:**  
JJ ALBANESE

**LOCATION:**  
CHILCO ST, MENLO PARK

**D&M TRAFFIC SERVICES ACKNOWLEDGES NO RESPONSIBILITY IN THE CASE OF ANY ACCIDENT, INJURY, OR DEATH OCCURRING DURING THE USE OF THESE PLANS. PLANS CANNOT BE DUPLICATED FOR USE BY ANY PERSONS NOT INCLUDED IN THIS CONTRACT WITHOUT THE CONSENT OF D&M TRAFFIC SERVICES, OR OWNER.**

REV LOG	DATE	DRAWING BY:
1	8-16-21	<i>W. Smith</i>
		SUBMITTAL DATE: 7-12-21
		TCP SHEET 2 OF 2



TEMP TCP FOR:

**ROAD CLOSURE**

D&M TRAFFIC SERVICES INC.  
845 Reed St. Santa Clara, Ca 95051  
408-436-1127





## STAFF REPORT

**City Council Meeting Date:** 9/21/2021  
**Staff Report Number:** 21-183-CC

**Consent Calendar:** **Adopt Resolution No. 6668 authorizing the city manager to rescind the portions of Emergency Order No. 2 in Fall 2021 related to the Arrillaga Family Gymnasium, City Council Chambers, City Hall, and Arrillaga Family Gymnastics Center**

### Recommendation

Staff recommends that the City Council adopt Resolution No. 6668 (Attachment A) authorizing the city manager to rescind the portions of Emergency Order No. 2 in Fall 2021 related to the Arrillaga Family Gymnasium, City Council Chambers, City Hall, and the Arrillaga Family Gymnastics Center as appropriate pending the Governor's decision to extend the temporary suspension of in person participation requirements of the Brown Act for public meetings and City Council direction on the restoration of gymnastics programming.

### Policy Issues

City Council sets policy and goals and provides direction to staff regarding municipal services to the Menlo Park community; allocates resources to support and maintain city facilities and operations and provide services to residents; and ratifies and/or rescinds local emergency orders.

### Background

On March 27, 2020, the City of Menlo Park issued Emergency Order No. 2 (Attachment C) that closed all City facilities to the public, including the Arrillaga Family Gymnasium, City Council Chambers, City Hall, and the Arrillaga Family Gymnastics Center. This precaution was necessary to protect public health by minimizing opportunities for congregation, both public and employee, during the COVID-19 pandemic.

On April 27, 2021, the City Council reviewed a four-phase plan for safely reopening City facilities to limited indoor public access (Attachment D), including the Arrillaga Family Gymnasium, City Council Chambers, City Hall, and the Arrillaga Family Gymnastics Center tentatively in Fall 2021.

On June 15, 2021, the State of California rescinded multiple public health restrictions and issued new guidance which allows local communities to reopen these facilities with some precautions to prevent the spread of COVID-19 in workplaces.

### Analysis

City Council authorization is needed to rescind and modify Emergency Order No. 2, to remove from the list of facility closures those facilities that are tentatively scheduled to reopen in Fall 2021 per the City's four-phase reopening plan (Attachment D):

- Arrillaga Family Gymnasium
- City Council Chambers
- City Hall
- Arrillaga Family Gymnastics Center

The necessary preparations to expand public access to facilities and services require significant investments of time and resources during a period when the organization's personnel resources are limited. Assuming the pandemic continues to recede over the course of the calendar year, and when the public health emergency has subsided, then staff will return to City Council to fully rescind Emergency Order No. 2.

The remaining facilities closed by Emergency Order No. 2 are scheduled for demolition and will not reopen. No additional action needs to be taken related to the emergency order as it pertains to these facilities due to construction of the Menlo Park Community Campus:

- Onetta Harris Community Center
- Menlo Park Senior Center

Should the City Council adopt Resolution No. 6641 authorizing the city manager to rescind the portions of Emergency Order No. 2 in Fall 2021 related to the Arrillaga Family Gymnasium, City Council Chambers, City Hall and Arrillaga Family Gymnastics Center, then the city manager will issue Emergency Order No. 10 to remove those facilities from the closure list (Attachment B.)

### **Impact on City Resources**

Programming expenditures, revenue expectations, and costs associated with making physical improvements to City facilities necessary to reopen are incorporated into the proposed operating budget for fiscal year 2021-22.

### **Environmental Review**

This action is not a project within the meaning of the California Environmental Quality Act (CEQA) Guidelines §§ 15378 and 15061(b)(3) as it will not result in any direct or indirect physical change in the environment.

### **Public Notice**

Public notification was achieved by posting the agenda, with the agenda items being listed, at least 72 hours prior to the meeting.

The City Council in duly noticed public meetings received relevant reports and notifications March 9, April 6, April 13 and April 27.

The Library Commission in duly noticed public meetings received relevant reports and notifications March 15, April 19 and May 17.

The Parks and Recreation Commission in duly noticed public meetings received relevant reports and notifications March 24, April 28 and May 26 and August 25.

**Attachments**

- A. Resolution No. 6668
- B. Emergency Order No. 10 rescinding portions of Emergency Order No. 2
- C. Emergency Order No. 2
- D. Hyperlink – City Council Staff Report #21-090-CC: [menlopark.org/DocumentCenter/View/27987/K1-20210427-CC-Expanding-public-access-to-facilities-services](https://menlopark.org/DocumentCenter/View/27987/K1-20210427-CC-Expanding-public-access-to-facilities-services)

Report prepared by:  
Sean Reinhart, Library and Community Services Director

Report reviewed by:  
Starla Jerome-Robinson, City Manager

**RESOLUTION NO. 6668**

**RESOLUTION OF THE CITY COUNCIL OF THE CITY OF MENLO PARK  
AUTHORIZING THE CITY MANAGER TO RESCIND THE PORTIONS OF  
EMERGENCY ORDER NO. 2 RELATED TO ARRILLAGA FAMILY  
GYMNASIUM, CITY COUNCIL CHAMBERS, CITY HALL, AND ARRILLAGA  
FAMILY GYMNASISTICS CENTER**

WHEREAS, on March 27, 2020, the City of Menlo Park issued Emergency Order No. 2 that closed all City facilities to the public, including the Arrillaga Family Gymnasium, City Council Chambers, City Hall, and Arrillaga Family Gymnastics Center, to protect public health and safety due to the COVID-19 pandemic; and

WHEREAS, on April 27, 2021, the City Council reviewed a four-phase plan for safely reopening City facilities to limited indoor public access, including the Arrillaga Family Gymnasium, City Council Chambers, City Hall, and Arrillaga Family Gymnastics Center in Autumn 2021; and

WHEREAS, on June 15, 2021, the State of California rescinded multiple public health restrictions and issued new guidance which allows local communities to reopen these facilities with some precautions to prevent the spread of COVID-19 in workplaces; and

WHEREAS, the City Council wishes to provide Menlo Park residents the opportunity to safely resume limited indoor public access to these facilities in accordance with the reopening sequence outlined in the aforementioned four-phase reopening plan;

WHEREAS, in reliance on the State of California's June 15, 2021 direction and rescission of health restrictions and because the City finds that the risks of COVID-19 have reduced with the increased vaccination rates in the City, County and State, the City Council wishes to reopen certain City facilities to the public including the Arrillaga Family Gymnasium, City Council Chambers, City Hall, and Arrillaga Family Gymnastics Center.

NOW, THEREFORE BE IT RESOLVED, that the City Council of the City of Menlo Park does hereby authorize the City Manager, as Director of Emergency Services, to revise Emergency Order No. 2 as more specifically shown in Exhibit A attached hereto and incorporated herein by this reference, by removing from Emergency Order No. 2 the Arrillaga Family Gymnasium, City Council Chambers, City Hall, and Arrillaga Family Gymnastics Center.

//

//

//

//

//

//

I, Judi A. Herren, City Clerk of Menlo Park, do hereby certify that the above and foregoing City Council Resolution was duly and regularly passed and adopted at a meeting by said City Council on the twenty-first day of September, 2021, by the following votes:

AYES:

NOES:

ABSENT:

ABSTAIN:

IN WITNESS WHEREOF, I have hereunto set my hand and affixed the Official Seal of said City on this twenty-first day of September, 2021.

---

Judi A. Herren, City Clerk

**DIRECTOR OF EMERGENCY SERVICES/CITY MANAGER  
EMERGENCY ORDER NO. 10**

WHEREAS, the Centers for Disease Control and Prevention has declared the novel coronavirus named “COVID-19” a serious public health threat;

WHEREAS, on March 3, 2020, and pursuant to Section 101080 of the California Health and Safety Code, the San Mateo County Health Officer (“Health Officer”) declared a local health emergency throughout San Mateo County related to COVID-19;

WHEREAS, on March 4, 2020, the Governor of the State of California declared a state of emergency to help the state prepare for the spread of COVID-19;

WHEREAS, on March 10, 2020, the San Mateo County Board of Supervisors ratified and extended the declaration of local health emergency;

WHEREAS, the Health Officer issued a statement on March 10, 2020, that evidence existed of widespread community transmissions of COVID-19 in San Mateo County;

WHEREAS, on March 11, 2020, the World Health Organization declared COVID-19 constituted a world pandemic;

WHEREAS, on March 11, 2020, the City Council of the City of Menlo Park declared a local emergency based on the COVID-19 world pandemic;

WHEREAS, on March 14, 2020, the Health Officer prohibited all public or private gatherings of 50 or more people and urged the cancelation of all gatherings of 10 or more people in a single confined space;

WHEREAS, on March 16, 2020, the Health Officer issued an order that, among other things, directed all individuals currently living within San Mateo County to shelter in their place of residence (“Shelter-in-Place Order”), and authorized individuals to leave their residences only for certain “Essential Activities,” Essential Governmental Functions,” or to operate “Essential Businesses,” all as defined in the Shelter-in Place Order;

WHEREAS, on March 19, 2020, Governor Newsom issue Executive Order No. N-33-20 ordering all individuals in the State of California to stay home or at their place of residence except as needed to maintain continuity of operations of the federal critical infrastructure sectors;

WHEREAS, on March 27, 2020, the City of Menlo Park issued Emergency Order No. 2 that closed all City facilities to the public, including the Arrillaga Family Gymnasium, City Council Chambers, City Hall, and the Arrillaga Family Gymnastics Center, to protect public health and safety from the COVID-19 pandemic;

WHEREAS, on April 27, 2021, the City Council reviewed a four-phase plan for safely reopening City facilities to limited indoor public access, including the Arrillaga Family Gymnasium, City Council Chambers, City Hall in September 2021 and the Arrillaga Family Gymnastics Center in November 2021; and

WHEREAS, on June 15, 2021, the State of California rescinded multiple public health restrictions and issued new guidance which allows local communities to reopen these facilities with some precautions to prevent the spread of COVID-19 in workplaces; and

WHEREAS, the City Council wishes to provide Menlo Park residents the opportunity to safely resume limited indoor public access to these facilities in accordance with the reopening sequence outlined in the aforementioned four-phase reopening plan; and

WHEREAS, in reliance on the State of California’s June 15, 2021 direction and rescission of health restrictions and because the City finds that the risks of COVID-19 have reduced with the increased vaccination rates in the City, County and State, the City Council wishes to reopen certain City facilities to the public including the Arrillaga Family Gymnasium, City Council Chambers, City Hall, and the Arrillaga Family Gymnastics Center; and

WHEREAS, during the existence of this local emergency, pursuant to Municipal Code Chapter 2.44, the City Manager as Director of Emergency Services is empowered to make and issue rules and regulations on matters reasonably related to the protection of life and property in the City of Menlo Park as affected by such emergency.

NOW, THEREFORE, the Director of Emergency Services does hereby make the following order:

- 1. ~~Effective September 21, 2021, the~~The portion of Emergency Order No. 2 closing the Arrillaga Family Gymnasium, City Council Chambers, City Hall, and the Arrillaga Family Gymnastics Center is hereby rescinded.
- 1-2. The City Manager is authorized to reopen Arrillaga Family Gymnasium, City Council Chambers, City Hall, and the Arrillaga Family Gymnastics Center at their sole discretion in Fall of 2021.
- 2-3. Facility users shall adhere to applicable State and County required requirements relating to playground use and other social distancing precautions.
- 3. ~~The City Manager reserves the right to modify this order.~~

Dated: \_\_\_\_\_

\_\_\_\_\_  
City Manager

Approved as to Form:

\_\_\_\_\_  
City Attorney

**CITY OF MENLO PARK DIRECTOR OF EMERGENCY SERVICES/CITY MANAGER  
EMERGENCY ORDER NO. 2**

WHEREAS, the Centers for Disease Control and Prevention has stated that based on current information a novel coronavirus named “COVID-19” is a serious public health threat;

WHEREAS, a complete clinical picture of this respiratory disease is not yet fully understood, though it is highly contagious;

WHEREAS, on March 3, 2020, and pursuant to Section 101080 of the California Health and Safety Code, the San Mateo County Health Officer (“Health Officer”) declared a local health emergency throughout San Mateo County related to COVID-19;

WHEREAS, on March 4, 2020, the Governor of the State of California declared a state of emergency to help the state prepare for the spread of COVID-19;

WHEREAS, the Health Officer issued a statement on March 10, 2020, that evidence exists of widespread community transmissions of COVID-19 in San Mateo County; WHEREAS, on March 10, 2020, the San Mateo County Board of Supervisors ratified and extended the declaration of a local health emergency;

WHEREAS, on March 11, 2020, the World Health Organization declared COVID-19 constituted a world pandemic;

WHEREAS, on March 11, 2020, the City Council of the City of Menlo Park declared a local emergency based on the current COVID-19 world pandemic and empowered the Director of Emergency Services to take all necessary actions;

WHEREAS, on March 14, 2020, the Health Officer prohibited all public or private gatherings of 50 or more people and urged the cancelation of all gatherings of 10 or more people in a single confined space;

WHEREAS, on March 16, 2020, the Health Officer issued an order that, among other things, directs all individuals currently living within San Mateo County to shelter in their place of residence (“Shelter-in-Place Order”), and authorizes individuals to leave their residences only for certain “Essential Activities”, “Essential Governmental Functions,” or to operate “Essential Businesses,” all as defined in the Shelter-in Place Order;

WHEREAS, Government Code Section 8634 empowers the Director of Emergency Services to promulgate orders and regulations necessary to provide for the protection of life and property;

WHEREAS, during the existence of this local emergency, pursuant to Municipal Code Chapter 2.44, the City Manager as Director of Emergency Services is empowered to



make and issue rules and regulations on matters reasonably related to the protection of life and property as affected by such emergency.

WHEREAS, on March 19, 2020, Governor Newsom issued Executive Order No. N-33-20 ordering all individuals in the State of California to stay home or at their place of residence except as needed to maintain continuity of operations of the federal critical infrastructure sectors;

WHEREAS, the Governor empowered local cities to take actions to preserve and protect the health and safety of their communities in light of their own circumstances;

WHEREAS, the City Council desires to do what it can to help slow the spread of COVID-19, reduce the load on local hospitals and emergency rooms, prevent unnecessary deaths, and preserve limited resources in order to allocate them to the most critical projects; and

NOW, THEREFORE, the City Manager as the Director of Emergency Services does hereby make the following order:

1. Public Facilities Closures. For the duration of the local emergency, the following public facilities shall be closed to the public: City Hall; Arrillaga Family Recreation Center; Arrillaga Family Gymnasium; Arrillaga Family Gymnastics Center; Burgess Pool; Belle Haven Pool; Onetta Harris Community Center; Menlo Park Senior Center; Menlo Park Main Library and Belle Haven Branch Library; all public restrooms and playgrounds located in all public parks; Burgess Park skate park; all public tennis courts, and all public basketball courts.
  
2. Effective date. This order shall be effective immediately and shall terminate upon the earlier of (1) Director of Emergency Services order or (2) cessation of local emergency.
  
3. Enforcement. This order shall be enforceable as a misdemeanor as provided in Menlo Park Municipal Code Section 2.44.110.

Dated: 3/27/2020

DocuSigned by:  
  
 6BD907BD261744C...  
 \_\_\_\_\_  
 Director of Emergency Services

Approved as to form:

DocuSigned by:  
  
 CD6C53C794F6491...  
 \_\_\_\_\_  
 Interim City Attorney



**STAFF REPORT**

**City Council**

**Meeting Date:**

**9/21/2021**

**Staff Report Number:**

**21-186-CC**

**Public Hearing:**

**Ordinance No. 1078 repealing and replacing Menlo Park Municipal Code Section 16.86.025**

**Recommendation**

Staff recommends City Council waive the first reading of Ordinance No. 1078 repealing and replacing Menlo Park Municipal Code section 16.86.025, included as Attachment A.

**Policy Issues**

Menlo Park Municipal Code Section 16.86.025 establishes a procedure for the City Council or any individual City Councilmember to appeal decisions of the Planning Commission, and provides that the City Council may meet to decide whether the appeal is on behalf of an individual City Councilmember or on behalf of the entire City Council.

**Background**

It is customary for cities to have procedures and regulations under which a City Council can call-up a Planning Commission's final decision on the matter. The Menlo Park Municipal Code does not have such a procedure. Instead, Menlo Park Municipal Code Section 16.86.025 requires City Councilmembers to formally appeal a decision of the Planning Commission if the City Councilmember wishes to call up and discuss the Planning Commission's decision. This requirement limits the City Council's ability to review Planning Commission decisions and the policy implications of such decisions. Furthermore, the manner in which section 16.86.025 is drafted suggests the City Council can be both the appellant and the decision maker on a City Council appeal.

**Analysis**

Staff recommends revising MPMC section 16.86.025 to establish procedures in which the City Council may call up final Planning Commission decisions. The proposed revisions would repeal the current procedures which require City Councilmembers to formally appeal a decision of the Planning Commission in order to discuss, reconsider and uphold or deny such decision. The proposed revisions would also remove the provisions of section 16.86.025, which require that where a Councilmember appeals a Planning Commission decision, the entire City Council must decide whether the appeal will be considered a full City Council appeal. This requirement is undesirable for a number of reasons, including that it suggests the full City Council must consider an appeal before the actual hearing on said appeal. Removing this provision would enable any one City Councilmember to call-up any decision of the Planning Commission, as opposed to requiring a majority of the City Councilmember to agree to an appeal of any decision of the Planning Commission.

### **Impact on City Resources**

There is no impact on City resources.

### **Environmental Review**

This action is not a project within the meaning of the California Environmental Quality Act (CEQA) Guidelines §§ 15378 and 15061(b)(3) as it will not result in any direct or indirect physical change in the environment.

### **Public Notice**

Public notification was achieved by posting the agenda, with the agenda items being listed, at least 72 hours prior to the meeting.

### **Attachments**

None.

Report prepared by:  
Nira F. Doherty, City Attorney

**ORDINANCE NO. 1078****ORDINANCE OF THE CITY COUNCIL OF THE CITY OF MENLO PARK  
REPEALING AND REPLACING MENLO PARK MUNICIPAL CODE SECTION  
16.86.025 OF THE MENLO PARK MUNICIPAL CODE**

WHEREAS, Menlo Park Municipal Code Chapter 16.86 – Appeals, governs the appeal process for decisions of the City of Menlo Park’s (“City”) Planning Commission; and

WHEREAS, Menlo Park Municipal Code section 16.86.025 empowers City Councilmembers to appeal decisions of the City’s Planning Commission, and moreover, requires that the City Council consider whether the City Councilmember’s appeal would be considered an appeal from the individual City Councilmember or an appeal from the City Council as a whole;

WHEREAS, Menlo Park Municipal Code section 16.86.025 also includes provisions relating to the payment of fees for appeal; and

WHEREAS, California Government Code section 65905.5(a) provides that a City may only hold five hearings to determine whether a proposed housing development project complies with applicable regulations; and

WHEREAS, the City Council has determined that repealing and replacing Section 16.86.025 of the Municipal Code will facilitate greater compliance with State law and will ensure that applicants received full due process protections.

**NOW THEREFORE, BE IS ORDAINED BY THE CITY COUNCIL OF THE CITY OF MENLO PARK:**

**SECTION 1. Findings.**

The above recitals are hereby declared to be true and correct findings of the City Council of the City of Menlo Park.

**SECTION 2. Section 16.86.025 is hereby repealed in its entirety and replaced as follows:**

16.86.025 Call-up by city council or councilmember

The city council or any member of the city council may call-up any final decision of the planning commission by filing a notice of call-up with the city clerk. Said notice shall identify the final decision of the planning commission that is being called up and shall be submitted to the city clerk no later than fifteen (15) days following the decision of the planning commission. A call-up hearing before the city council shall be held at a city council meeting, insofar as practicable no later than forty-five (45) days following the city clerk’s receipt of the notice of call-up.

**SECTION 3. Severability**

If any provision or clause of this ordinance or the application thereof to any person or circumstance is held to be unconstitutional or to be otherwise invalid by a final judgment of any court or competent jurisdiction, such invalidity shall not affect other provisions or clauses or

application, and to this end, the provisions and clauses of this ordinance are declared to be severable.

**SECTION 4. California Environmental Quality Act**

The City Council finds that the adoption and implementation of this Ordinance are exempt from the provisions of the California Environmental Quality Act under section 15061(b)(3) in that the City Council finds there is no possibility that the implementation of this Article may have significant effects on the environment.

**SECTION 5. Publication; Effective Date.** This Ordinance shall be published once, in full or in summary form, after its final passage, in a newspaper of general circulation, published, and circulated in the City of Menlo Park, and shall be in full force and effect thirty (30) days after its final passage. If published in summary form, the summary shall also be published within fifteen (15) days after the adoption, together with the names of those Councilmembers voting for or against same, in a newspaper of general circulation published and circulated in the City of Menlo Park, County of San Mateo, State of California.

INTRODUCED on the twenty-first day of September 2021.

PASSED AND ADOPTED as an ordinance of the City of Menlo Park at a regular meeting of said City Council on the XXXX day of XXXX, 2021 by the following vote:

AYES:

NOES:

ABSENT:

ABSTAIN:

APPROVED:

\_\_\_\_\_  
Drew Combs, Mayor

ATTEST:

\_\_\_\_\_  
Judi A. Herren, City Clerk



**STAFF REPORT – CONTINUED FROM 9/14/2021**

**City Council**

**Meeting Date:**

**9/14/2021 9/21/2021**

**Staff Report Number:**

**21-173-CC**

**Regular Business:**

**Adopt Resolution No. 6663 to approve permanent installation of Belle Haven neighborhood traffic management plan**

**Recommendation**

Staff recommends that the City Council adopt Resolution No. 6663 (Attachment A) to approve permanent installation of the Belle Haven neighborhood traffic management plan.

**Policy Issues**

The development of the Belle Haven Neighborhood traffic management plan (Plan) and its implementation fulfill “Mitigation Measure TRA-3.1” of the mitigation monitoring and reporting program (MMRP) established in the Facebook campus expansion project final environmental impact report (FEIR) approved in 2016. This was identified as a mitigation measure due to the potential for the Facebook Campus Expansion project to exacerbate cut-through traffic in the neighborhood. (The Plan is not a negotiated benefit of the recorded development agreement for the project.) At the request of the City Council, this MMRP requirement is included in the City’s capital improvement program and considered part of staff’s baseline work.

As established by the Belle Haven traffic calming plan agreement November 12, 2020, between the City and Hibiscus Properties, LLC (Facebook), the City Council needs to identify and provide final direction on permanent measures for installation before October 1, 2021. As a result, approval by the City Council at a special meeting (if needed) no later than September 30, 2021 would be required. Deferral or continuance of this item beyond October 1 will result in Facebook providing a one-time in-lieu lump sum fee payment of \$500,000 and relinquish their obligation to construct the selected measures.

**Background**

On August 20, 2019, the City Council approved the final revised Plan, adopted Resolution No. 6492 to remove on-street parking for intersection bulbouts, and amended the standard implementation process, as outlined in the City’s neighborhood traffic management program (NTMP) approved in 2004, to expedite the installation process. After the Plan was approved, staff continued to work with Parisi Transportation Consulting (Parisi) to prepare design plans and started coordination with outside agencies. Parisi was selected by the City and funded by Facebook to provide expertise on the development and design of the Plan.

In June 2020, temporary traffic calming measures within City jurisdiction were installed. Additionally, schematic design plans were submitted to the San Francisco Public Utilities Commission (SFPUC) for improvements along Ivy Drive (Hetch Hetchy pipelines) and Caltrans for improvements along Willow Road (State Route 114) in October 2020 for initial review.

Table 1 provides a summary of the locations, jurisdictions and changes to proposed measures based on

field evaluations and coordination with other agencies.

Table 1: Plan details				
Location	Street segments	Jurisdiction <sup>1</sup>	Initial proposed measures <sup>1</sup>	Final proposed measure <sup>1</sup>
Chilco Street	Terminal Avenue to Newbridge Street	City	Speed feedback signs, signing and striping	Speed feedback signs, signing and striping
Newbridge Street	Chilco Street to Willow Road	City	Bulbouts and striping	Bulbouts and striping
Terminal Avenue	Del Norte Avenue to Chilco Street	City	Bulbouts and striping <sup>2</sup>	Bulbouts and striping <sup>2</sup>
Chilco Street/ Hamilton Avenue/ Newbridge Street	At neighborhood entry points	City	Gateway treatments	Gateway treatments <sup>3</sup>
Hamilton Avenue	At Hamilton Park	City	Speed hump	Speed hump
Ivy Dr.	Chilco Street to Willow Road	SFPUC	Bulbouts, raised intersections, speed feedback signs, gateway treatments, signing and striping, median nose improvements	Signing and striping, median nose improvements <sup>4</sup>
Willow Road	At Newbridge Street	Caltrans	Signal operation and equipment upgrades	Signal operation <sup>5</sup> and equipment upgrades

Notes:

1. Due to expected lengthy approval timelines from SFPUC and Caltrans, the City Council approved staff’s recommendation to implement the trial implementation phase only for City jurisdiction measures and utilize its post-trial feedback for decisions related to permanent installation for City, Caltrans and SFPUC jurisdiction measures.
2. Based on cut-through survey results, Facebook is responsible for bulbouts on Almanor Avenue and Modoc Avenue, while the City is responsible for Hill Avenue and Plumas Avenue.
3. Chilco Street near the Fire Station is considered infeasible due to existing roadway constraints.
4. Speed feedback signs and gateway treatments are considered infeasible due to the San Francisco Public Utilities Commission’s (SFPUC) requirement for any measures with a foundation to be at least 20 feet away from the edge of their utility line, which would require these measures to be installed partially or completely outside the public right-of-way. Raised intersections and bulbouts are considered infeasible due to conflict with street repair/maintenance guidelines such as street sweeping.

Three operational safety improvements as follows, assuming Newbridge Street is a north-south roadway: a) Reverse the order of the Newbridge Street left turns by assigning the lead (first) phase to northbound left to reduce aggressive drivers interacting with pedestrians. b) Eliminate the conflict between Newbridge Street southbound left and pedestrian crossing Willow Road by providing a dedicated left turn. c) Prohibit Newbridge Street southbound right when Willow Road eastbound left is activated using a “blank out” sign to eliminate conflicts between vehicles on Newbridge Street and those accessing the Willow Road frontage road.

Additionally, SFPUC’s review yielded the following procedural updates for the Ivy Drive measures:

- Potholing, a construction activity performed to ensure sufficient vertical clearance from underground utility lines, is required and will lengthen the overall approval timeline
- The City will be required to execute a licensing agreement and pay an annual licensing fee. The City will be responsible for the annual payment (anticipated to be less than \$3000 annually with an annual adjustment according to the consumer price index) and staff has initiated a dialogue with SFPUC.

On March 23, 2021, staff presented to the City Council a set of revisions to the previously approved implementation process as a result of the unexpected COVID-19 pandemic, which centered on data

collection and a neighborhood-wide community survey. A hyperlink of the staff report is provided in Attachment B.

## **Analysis**

### Data collection

Roadway congestion has not yet returned to pre-COVID conditions. Therefore, current traffic data would not provide a clear picture of the efficacy of the trial measures. Instead, staff elected to collect new roadway and intersection data at key neighborhood locations to provide an overview of current patterns.

In April 2021, roadway and intersection transportation volume and speed data were collected at key neighborhood locations to provide an overview of current travel patterns and behaviors. The new data, along with pre-pandemic data collected before the trial installation, are presented in Attachment C.

In general, new pedestrian, bicycle and vehicular volumes decreased when compared to pre-pandemic data. This is consistent with overall transportation patterns exhibited due to the ongoing pandemic. The daily roadway vehicle volumes dropped approximately 8 to 35 percent, while the intersection vehicle volumes dropped approximately 11 to 66 percent.

The measured 85<sup>th</sup> percentile speed generally ranges from 23 to 29 miles per hour (mph) when compared to the pre-pandemic data of 24 to 29 mph. All four surveyed locations experienced a 2 mph or less differential. The 85<sup>th</sup> percentile speed is defined as the speed at or below which 85 percent of all observed free flowing vehicles traveled.

### Community survey

In late June, approximately 1,900 survey packages containing an introductory letter, paper surveys in English and Spanish, and a link to a fillable online version of the same survey, were mailed out to all Belle Haven residents (e.g., renters, owners, rental property owners) and businesses (business owner, property owner, etc.) The survey remained open until July 23, which was extended in response to a request from the community for additional time.

Additionally, the City posted the survey information on all City social media platforms (i.e., Nextdoor, Facebook, etc.) to encourage participation. A copy of the survey is included as Attachment D.

Overall, staff received 94 unique responses (i.e., 45 paper, 47 online, 1 phone, 1 email.)

The following details the general information about the survey responders:

- 12 percent (11 responders) were renters, 76 percent (71 responders) were owners, 2 percent (2 responders) were businesses, 10 percent (10 responders) identified as “other”
- 65 percent (61 responders) were Belle Haven residents/businesses through voluntary self-reporting
- 51 percent (48 responders) knew of the Plan before the survey

Table 2 summarizes the survey responses on the Plan as a whole (note some respondents left questions blank, thus the inconsistent total responses for each question):



Table 2: General survey summary		
Topic	Total responses	Breakdown
Severity of cut-through traffic during pre-pandemic times	87	93% considered it a problem 7% considered it not a problem
Degree of impact these trial installations (i.e., temporary bulbouts, speed feedback signs, etc.) have made to the neighborhood	89	57% considered it positive 18% neutral 25% considered it negative
Changes to driving patterns as a result of the turn restrictions	91	34% changed their pattern 51% remained the same 1% do not drive 14% uncertain
Levels of benefits to vehicle circulation from these trial installations	90	51% considered them beneficial 36% neutral 14% considered them not beneficial

Table 3 summarizes the key general comments from those expressing support and opposition to the Plan.

Table 3: Key survey comments	
Supportive of Plan	Opposed to Plan
Raises awareness for drivers, pedestrians and bicyclists	Turn restrictions are inconvenient to residents
Fewer traffic violations	City needs to address developments and traffic on major corridors
Some reduction in speed with speed feedback signs	Difficult to attribute any benefits to the Plan given the ongoing pandemic
Increased pedestrian safety	Reassign resource for more police enforcement and open up streets

Survey results on specific measures and final recommendations

The following are categorized based on each improvement measures. As stated in the Background section, measures that received a simple majority (i.e., >50 percent) approval from respondents will be recommended for permanent installation.

Speed feedback signs – Chilco Street between Hamilton Avenue and Ivy Drive

Based on 83 survey responses, 4 percent noticed an increase in speed after the installation, 24 percent noticed a decrease in speed, and 72 percent noticed no change in speed.

While this improvement did not reach the >50 percent positive feedback, the results are generally positive. Additionally, survey comments toward this improvement were mostly positive. The 2021 speed surveys, which were measured on Chilco Street between Terminal Avenue and the railroad tracks, indicated a small decrease since 2017 in the eastbound direction (i.e., 27 mph versus 29 mph) and no change in the westbound (i.e., both at 25 mph.)

Temporary bulbouts and gateways – in City jurisdiction

The survey started with a general question on whether the temporary flexible post bulbouts should be converted to permanent concrete bulbouts. Based on 82 survey responses, 52 percent supported the proposal, 32 percent opposed, while 16 percent expressed neutrality.

In April 2021, staff took photos of the temporary bulbouts that showed scuffmarks which typically indicates physical contact from vehicles and/or bicycles. The survey included those photos and solicited feedback on whether to prioritize pedestrian safety or focus on vehicle maneuverability, if the City decides to proceed with permanent installation. Based on 89 survey responses, 57 percent supported prioritizing pedestrian safety, 22 percent supported focusing vehicle maneuverability, while 21 percent expressed neutrality. Table 4 summarizes some of the key reasons from the two opinions.

Table 4: Survey results – permanent bulbout installation	
Support	Opposition
Reduced vehicular turning speed	Potential damage to turning vehicles
Raised driver awareness	Potential collision between turning vehicle and oncoming vehicles
Reduced pedestrian crossing distance	Did not reduce vehicular straightaway speed

Furthermore, the survey solicited feedback on a preferred permanent concrete bulbout design, which included a “traditional” bulbout design and a “detached” bulbout design. Based on the survey responses, both options received approximately equal support.

As a result, staff directed Parisi to explore “traditional” bulbout design unless there are significant constraints (e.g., significant impact to the storm drain infrastructure.) Based on preliminary evaluation, traditional bulbouts would provide lesser ongoing maintenance and are anticipated to be feasible on City-owned streets (i.e., Terminal Avenue and Newbridge Street) given the existing storm drain infrastructure.

Ivy Drive improvements (i.e., crosswalks and medians, bulbouts)

Based on 84 survey responses, 49 percent supported proceeding with permanent installation for all improvements, 26 percent opposed, while 25 percent expressed neutrality.

Traditional bulbouts are infeasible on Ivy Drive, since no underground storm drain line exists due to the SFPUC jurisdiction. Staff explored detached bulbouts, however, they will present a significant demand for ongoing maintenance, especially in the fall season when trees drop their leaves and can block the flow of water through the bulbout. Combined with the minimal support for the proposed bulbouts, bulbouts are not recommended on Ivy Drive, as summarized further below.

Willow Road and Newbridge Street signal modifications

Based on the three proposed modifications identified in the footnote of Table 1 above, staff included a specific survey question about the prohibition of the southbound right on Newbridge Street (assumed north-south) when eastbound left on Willow Road (assumed east-west) is activated. This turn restriction would be achieved by using a “blank out” sign to eliminate conflicts between vehicles on Newbridge Street and those accessing the Willow Road frontage road. Staff elected to highlight this in the survey because of its potential ramification to congestion on Newbridge Street by increasing backups for residents attempting to turn right onto Willow Road. An existing blank out sign is installed at the intersection of Bayfront Expressway and Chilco Street.

Based on 84 survey responses, 33 percent were aware of this proposed modification before the survey and 67 percent were not.

The survey also solicited general feedback on this improvement. The prevailing concern is adding more congestion to an already long queue and wait time on Newbridge Street, particularly during the morning

peak hour, when residents are leaving for work, school, etc. This community feedback was reflected in a modification to the proposed turn restriction blank out sign in the final recommendations, to only operate during the weekday evening peak hours to avoid further congestion during the morning peak hours.

### Other considerations

The survey also solicited general feedback about the neighborhood, as summarized below:

- More police traffic enforcement
- Enforcement should address the issue of vehicles doing donuts at intersections
- More bike lane improvements
- More speed humps neighborhood wide
- More improvements for Pierce Road (e.g., reduce speeding, more pedestrian and bicycle friendly)
- The Willow frontage road serving businesses and residents should be re-evaluated (i.e., double parking, street directionality, jaywalking)
- Major corridor signal timing should be re-evaluated (i.e., Willow Road, Bayfront Expwy.)
- Keep the signal on Chilco Street at Instagram driveway green

While this feedback is outside the scope of this project, staff separated them into two categories and took applicable actions:

- Feedback related to police enforcement was shared with the appropriate Police Department staff member
- Feedback related to the Transportation Division will be considered for future projects. The last two listed points, signal timing on major corridors is underway, and modifying the signal on Chilco Street is completed.

### Complete Streets Commission recommendations

On August 11, 2021, staff presented these findings to the Complete Streets Commission with the following permanent implementation recommendations:

- Speed feedback signs – retain the permanent measure on Chilco Street
- Temporary bulbouts and gateways in City jurisdiction – proceed with permanent installation after consultation with Parisi on ideal bulbout design
- Ivy Drive improvements – continue to coordinate with SFPUC with intent for permanent installation for improvements
- Willow Road and Newbridge Street signal modifications – continue to coordinate with Caltrans with intent for permanent installation for all three modifications, but with one alteration: activate the turn restriction blank out sign between 4 p.m. to 6 p.m. on weekdays

A hyperlink of the staff report is provided in Attachment E.

After discussion, the Commission voted (8-0-0-1, with one commissioner absent), in favor of most recommendations, except the permanent installation of bulbouts on Newbridge Street. In its place, the Commission recommended consideration of other temporary or permanent measures that achieve the current objectives without impacting bicycle travel.

Recognizing the City's future goal of sidewalk widening on Newbridge Street (i.e., transportation master plan project #28), which would use the existing shoulder space, the Commission explained that the shoulder space is being used by bicyclists to avoid interacting with vehicles. As a result, permanent intersection bulbouts would require bicyclists to merge more into the flow of vehicle traffic while riding on Newbridge Street. Additionally, there is not sufficient data to support a heavier demand from one alternative travel

mode over the others to warrant permanent bulbout installation, which is intended as a pedestrian improvement by shortening the crosswalk distance.

Additionally, the Commission advised staff to explore:

- Installing a bike pathway on the existing Ivy Drive center medians with SFPUC
- Installing speed humps along the studied segments of Chilco Street and Newbridge Street with the Fire District

#### Final recommendations

The following summarizes four additional evaluations conducted after the Complete Streets Commission meeting:

- Temporary bulbouts on Newbridge Street - As noted by the Commission, temporary bulbouts would provide additional space for bicyclists until the sidewalks are eventually widened. However, staff believes that while permanent bulbouts may create a need for bicyclists using the shoulder space to shift around intersections, they strengthen the original Plan intent to slow down right turning vehicles and increase pedestrian crossing safety, as instructed by community feedback when the Plan was being developed. As a result, staff is recommending the permanent installation of bulbouts on Newbridge Street.
- Bike pathway on Ivy Drive - Staff reviewed the latest SFPUC guidelines and determined that bike pathways on Ivy Drive center medians are not permitted.
- Speed humps on Chilco Street and Newbridge Street – Staff reached out to the Fire District and due to Chilco Street and Newbridge Street being primary fire response routes, speed humps could potentially slow down response time and are not preferred by the Fire District. Based on the 2021 speed surveys, the measured 85<sup>th</sup> percentile speeds for Chilco Street was 27 mph on eastbound and 25 mph on westbound, compared to the 25 mph posted speed. The measured 85<sup>th</sup> percentile speeds for Newbridge Street was 23 mph on northbound and 26 mph on southbound, compared to the 25 mph posted speed. The results did not warrant additional measures.
- Ivy Drive – New median noses will be installed, where feasible, along the center median to enhance pedestrian safety and improve access in the crosswalks for those with disabilities. However, Ivy Drive currently lacks the existing storm drain infrastructure for traditional bulbouts and staff has significant concerns with the required level of maintenance associated with detached bulbouts and the potential for ponding water created by the bulbouts. As a result, staff is not recommending the permanent installation of bulbouts on Ivy Drive.

In summary, staff is recommending the following measures for permanent installation:

- Speed feedback signs – retain the permanent measure on Chilco Street.
- Temporary bulbouts in City jurisdiction – proceed with permanent installation including Newbridge Street
- Gateways on Newbridge Street and Hamilton Avenue between Willow Road and Carlton Avenue – proceed with permanent installation
- Ivy Drive improvements – continue to coordinate with SFPUC with intent for permanent installation of crosswalks and median nose modifications
- Willow Road and Newbridge Street signal modifications – continue to coordinate with Caltrans with intent for permanent installation for all three modifications, but with one change: activate the turn restriction blank out sign between 4 p.m. to 6 p.m. only on weekdays, in response to community concern that it would further congest Newbridge Street during the morning peak hours.

### Next steps

Staff will incorporate City Council direction to the recommendations, if necessary. Staff will then notify Facebook and commence the requisite steps to initiate final design and implementation.

### **Impact on City Resources**

As a required condition of approval for a development project, staff time on the Belle Haven traffic calming study, development, and implementation of the Plan is considered part of the baseline City service levels. The trial and permanent implementation costs of measures in the Final Plan will be funded by Facebook (Hibiscus Properties, LLC) based on the 2017 neighborhood cut-through traffic survey that identified Chilco Street, Ivy Drive between Chilco Street and Willow Road, Newbridge Street between Chilco Street and Willow Road, and Terminal Avenue east of Modoc Avenue to be the main cut-through routes.

Bulbouts on Terminal Avenue west of Modoc Avenue are included to improve pedestrian crossing safety and create a uniform treatment along Terminal Avenue. Bulbouts west of Modoc Avenue would be designed and constructed with existing funds in the five-year capital improvement program, in the transportation projects (Minor) project.

### **Environmental Review**

The implementation of the Plan is categorically exempt under Class 1 (Existing Conditions) and Class 4 (Minor Modifications) of the State of California Environmental Quality Act Guidelines.

### **Public Notice**

Public notification was achieved by posting the agenda, with the agenda items being listed, at least 72 hours prior to the meeting. Additionally, the introductory letter in the survey package notified the neighborhood of the September 14, 2021 meeting.

### **Attachments**

- A. Resolution No. 6663
- B. Hyperlink – March 23, 2021, City Council staff report: [menlopark.org/DocumentCenter/View/27673/J2-20210323-BH-traffic-management-plan-update](https://menlopark.org/DocumentCenter/View/27673/J2-20210323-BH-traffic-management-plan-update)
- C. Roadway and intersection transportation data
- D. Community survey
- E. Hyperlink – August 11, 2021 Complete Streets Commission staff report: [menlopark.org/DocumentCenter/View/29323/SR-Complete-Streets-Commission-Permanent-Installation](https://menlopark.org/DocumentCenter/View/29323/SR-Complete-Streets-Commission-Permanent-Installation)

Report prepared by:  
Kevin Chen, Senior Transportation Engineer

Report reviewed by:  
Kristian Choy, Senior Transportation Engineer  
Hugh Louch, Assistant Public Works Director - Transportation

**RESOLUTION NO. 6663**

**RESOLUTION OF THE CITY COUNCIL OF THE CITY OF MENLO PARK  
AUTHORIZING THE INSTALLATION OF PERMANENT TRAFFIC CALMING  
DEVICES IN THE BELLE HAVEN NEIGHBORHOOD NECESSITATED BY THE  
NEIGHBORHOOD TRAFFIC CALMING PLAN**

WHEREAS, on November 1 and November 15, 2016, the City Council approved the Facebook Campus Expansion Project Final Environmental Impact Report (FEIR). The FEIR established a set of feasible mitigation measures to reduce the severity and magnitude of traffic impacts generated by the project; and,

WHEREAS, one mitigation measure required in the FEIR is the development, design, and implementation of a Belle Haven Neighborhood Traffic Calming Plan (Plan) that is intended to address neighborhood cut-through traffic through the use of traffic calming measures; and,

WHEREAS, on August 20, 2019, the City Council approved the final revised Plan to initiate the design and implementation of the Plan, adopted Resolution No. 6492 to remove on-street parking for up to 50 bulbouts; and,

WHEREAS, in June 2020, temporary traffic calming measures within City jurisdiction were installed as a trial; and,

WHEREAS, in June and July 2021, the City surveyed approximately 1900 residents and business owners in the Belle Haven neighborhood to determine the level of support for permanent improvements; and,

WHEREAS, on August 11, 2021, the Complete Streets Commission recommended the permanent installation of measures on Terminal Avenue, Chilco Street, Ivy Drive, and minor crossing streets along Newbridge Street, but recommended against permanent bulbouts on Newbridge Street; and,

WHEREAS, the City of Menlo Park, acting by and through its City Council, having considered and been fully advised in the matter and good cause appearing therefore.

NOW, THEREFORE, BE IT RESOLVED, the City Council of Menlo Park does hereby authorize the permanent installation of all measures shown on Exhibit A.

//  
  
//  
  
//  
  
//  
  
//  
  
//  
  
//

I, Judi A. Herren, City Clerk of Menlo Park, do hereby certify that the above and foregoing City Council resolution was duly and regularly passed and adopted at a meeting of said City Council on the fourteenth day of September, 2021, by the following votes:

AYES:

NOES:

ABSENT:

ABSTAIN:

IN WITNESS WHEREOF, I have hereunto set my hand and affixed the Official Seal of said City on this fourteenth day of September, 2021.

---

Judi A. Herren, City Clerk

Belle Haven Neighborhood  
Traffic Calming  
Plan







ROADWAY SEGMENT					AVERAGE DAILY TRAFFIC		
Location	Street	Segment		Approach	2017	2021	% Change
		From	To				
A	Chilco Street	Terminal Avenue	Railroad Crossing	EB	2,055	1,206	-41%
				WB	2,720	1,374	-49%
B	Hamilton Avenue	Carlton Avenue	Madera Avenue	NB	1,721	1,350	-22%
				SB	1,779	1,379	-22%
C	Ivy Drive	Carlton Avenue	Willow Road	NB	1,128	994	-12%
				SB	2,038	1,314	-36%
D	Newbridge Street	Carlton Avenue	East of Carlton Avenue	NB	4,740	4,009	-15%
				SB	4,650	4,063	-13%

**Belle Haven Neighborhood Traffic Management Plan**  
**Average Daily Traffic**

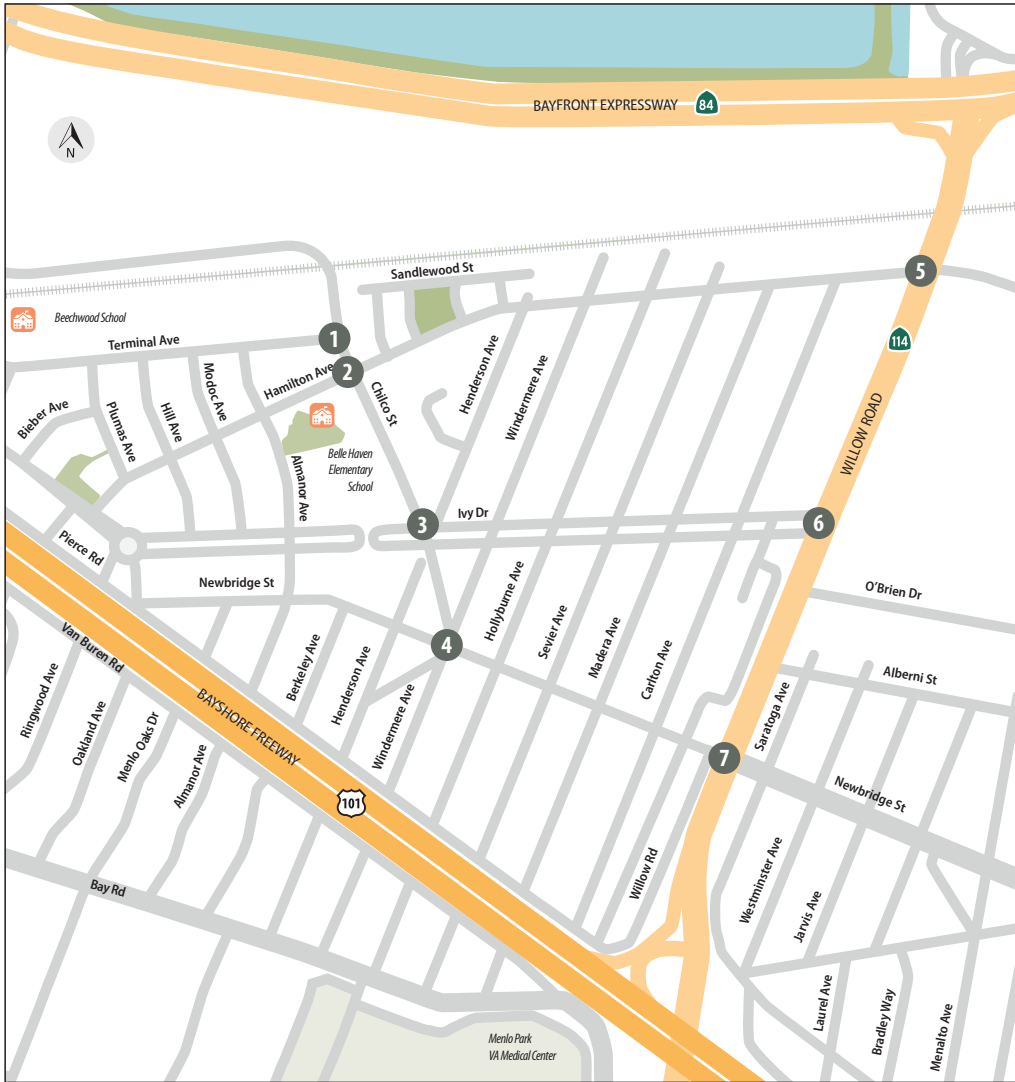

**Intersection Counts AM Peak Hour**

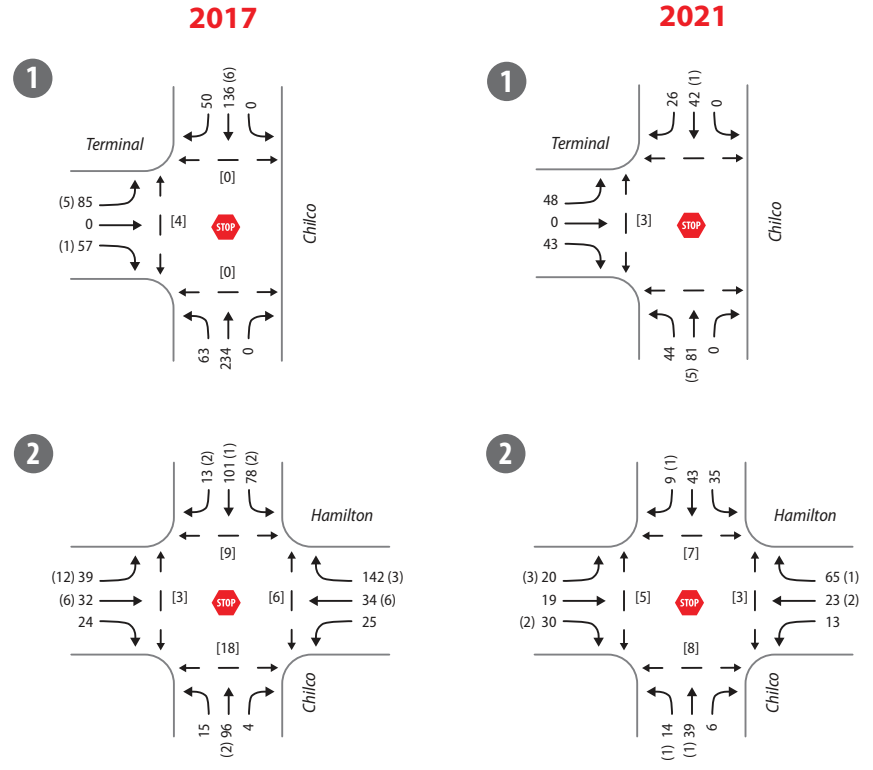

**LEGEND**

- # Study Intersection
- xx Automobile
- (xx) Bicycle
- [xx] Pedestrian
- Signalized Intersection
- All way Stop-Controlled

**Belle Haven Neighborhood Traffic Management Plan**  
**Intersection Counts AM Peak Hour**



# Intersection Counts AM Peak Hour

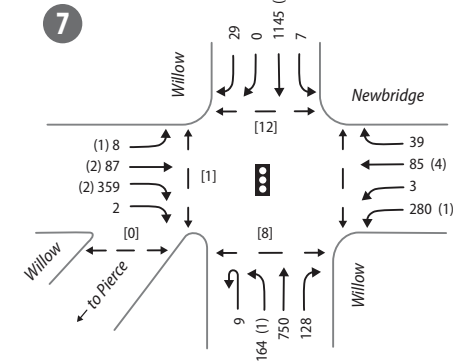
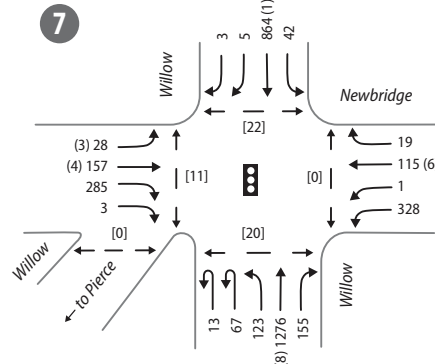
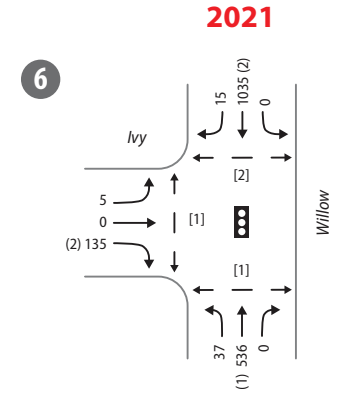
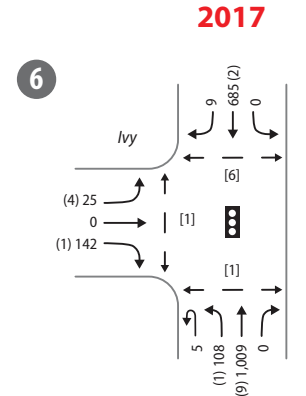
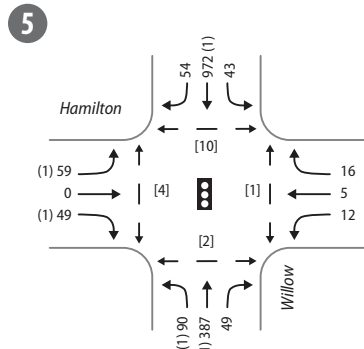
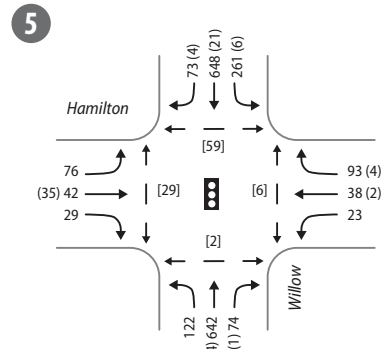
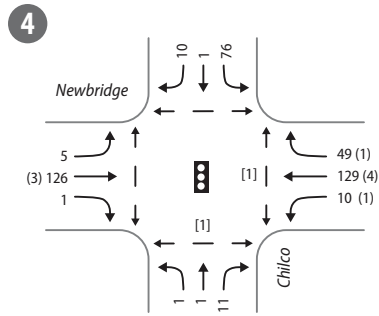
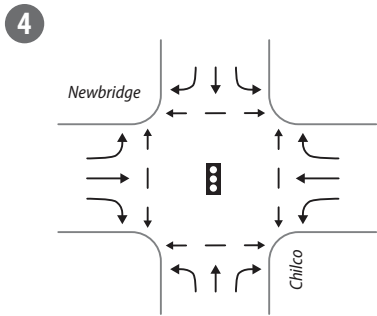
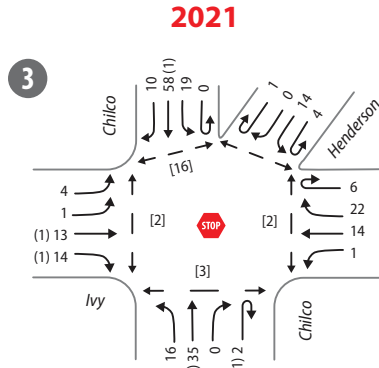
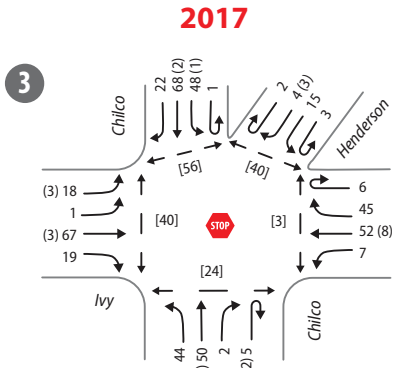

**LEGEND**

- # Study Intersection
- xx Automobile
- (xx) Bicycle
- [xx] Pedestrian
- Signalized Intersection
- STOP All way Stop-Controlled



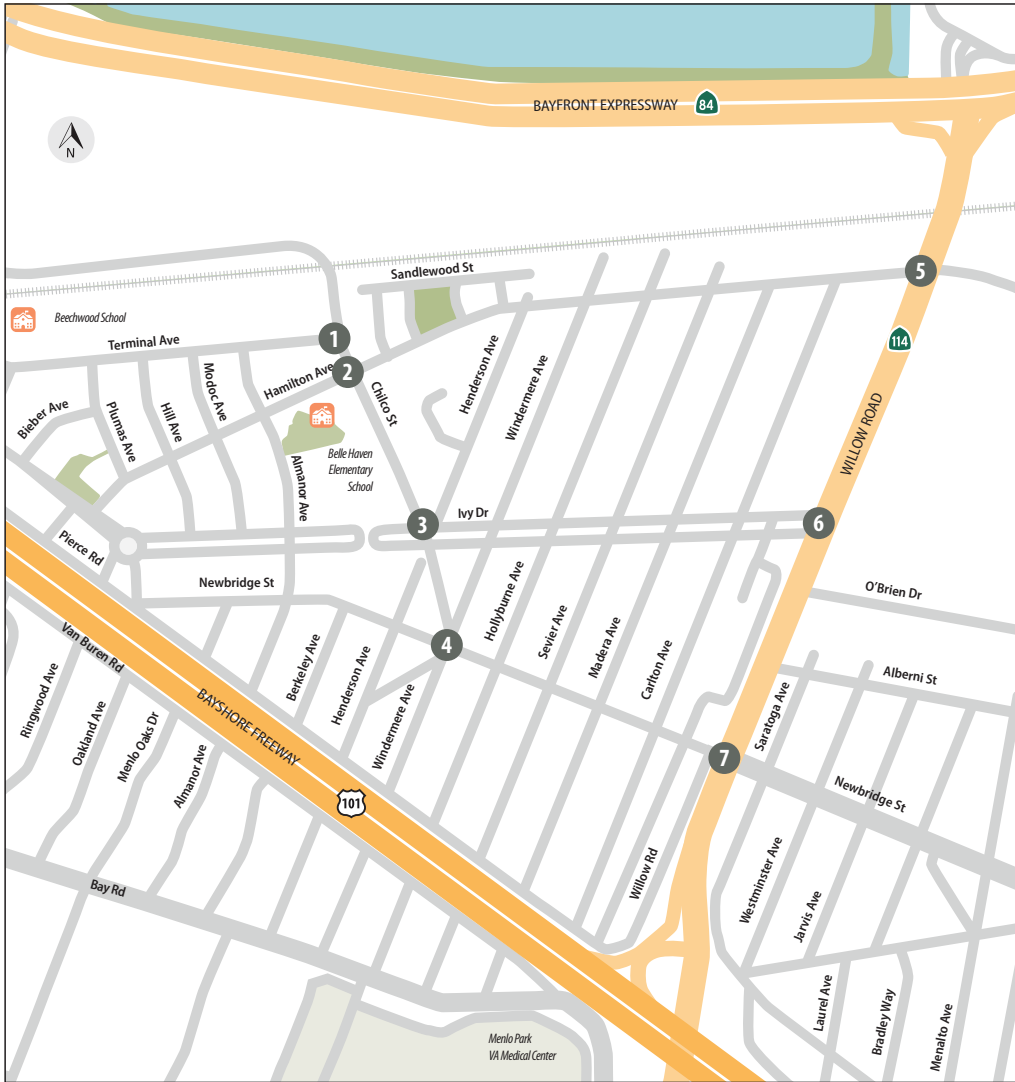

### Intersection Counts PM Peak Hour

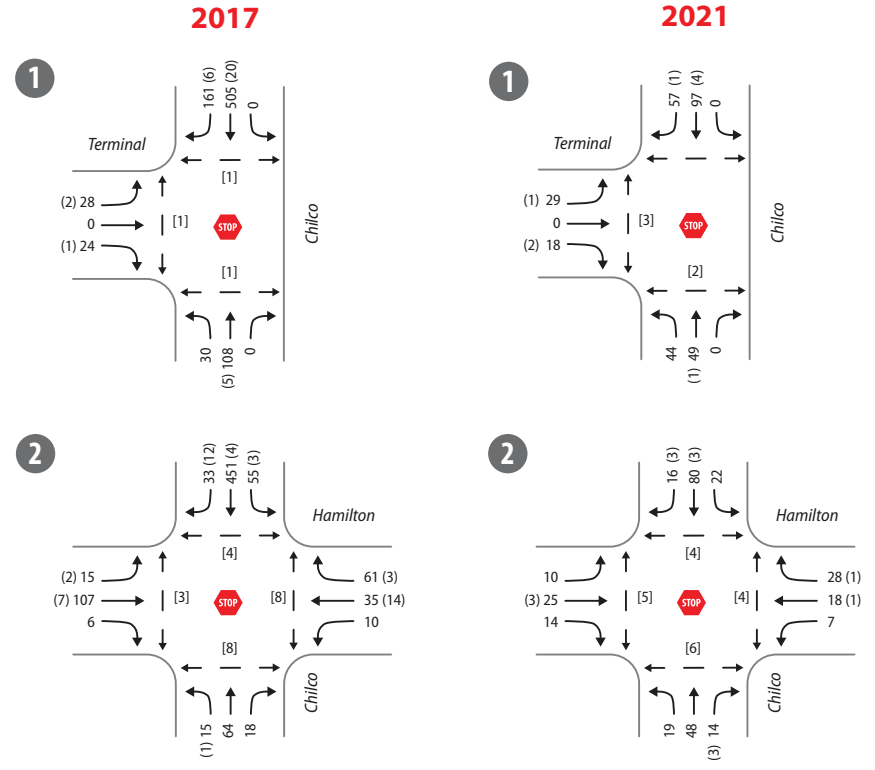

**LEGEND**

- # Study Intersection
- xx Automobile
- (xx) Bicycle
- [xx] Pedestrian
- Signalized Intersection
- STOP All way Stop-Controlled

## Belle Haven Neighborhood Traffic Management Plan Intersection Counts PM Peak Hour



# Intersection Counts PM Peak Hour

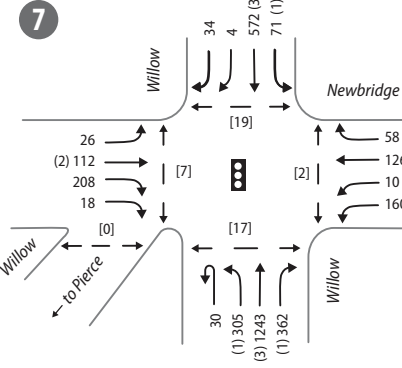
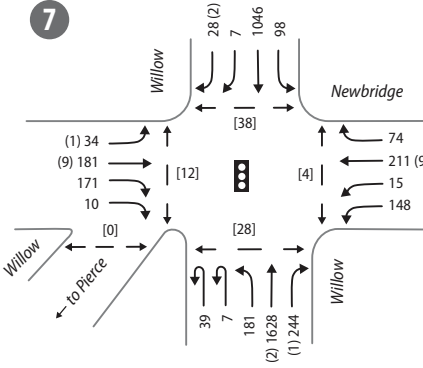
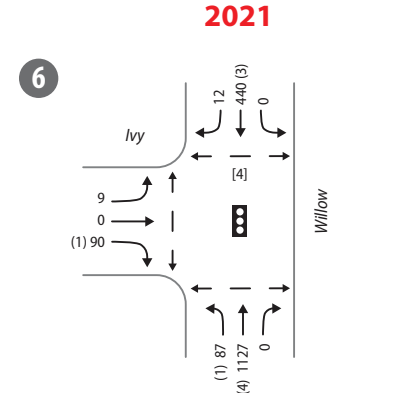
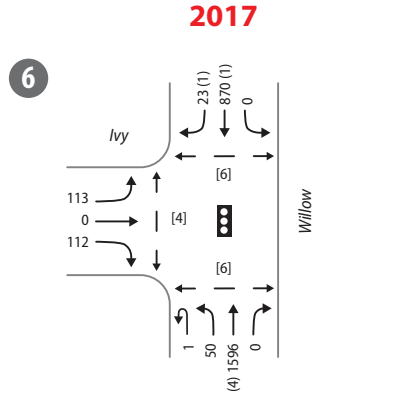
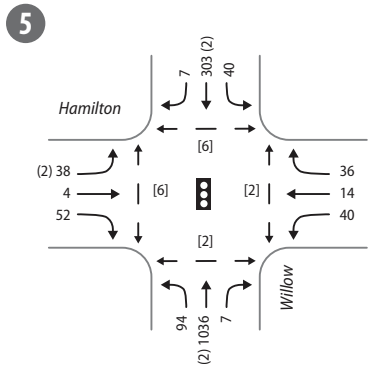
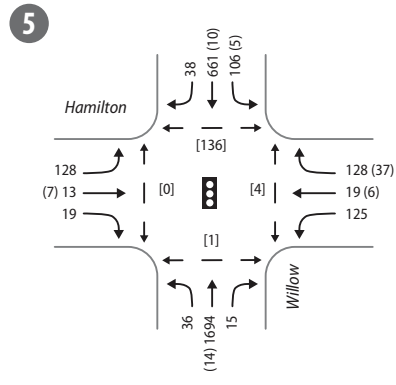
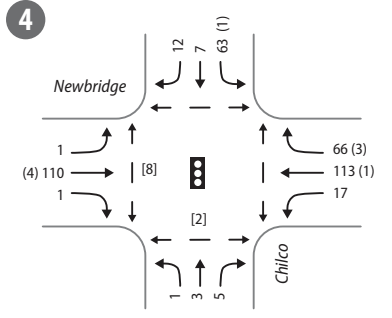
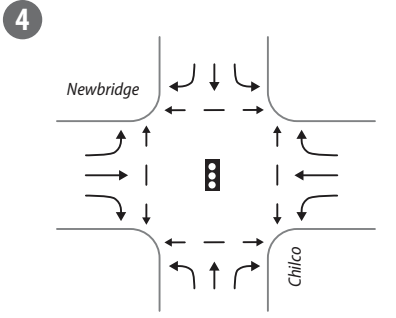
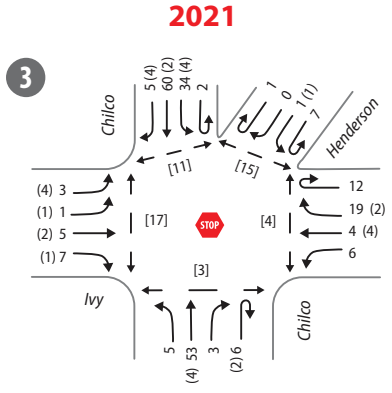
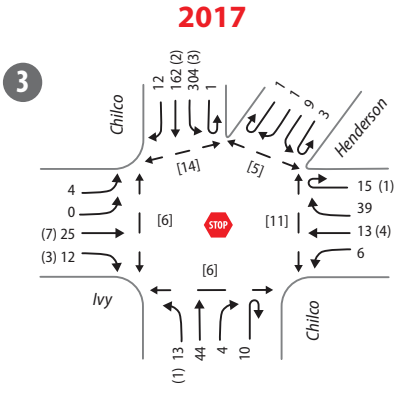

**LEGEND**

#	Study Intersection	xx	Automobile	⬛	Signalized Intersection
(xx)	Bicycle	STOP	All way Stop-Controlled		
[xx]	Pedestrian				





ROADWAY SEGMENT					VEHICULAR SPEED			
					2017		2021	
Location	Street	Segment		Approach	85th Percentile	Speed Limit	85th Percentile	Speed Limit
		From	To					
A	Chilco Street	Terminal Avenue	Railroad Crossing	EB	29	25	27	25
				WB	25	25	25	25
B	Hamilton Avenue	Carlton Avenue	Madera Avenue	NB	27	25	29	25
				SB	28	25	29	25
C	Ivy Drive	Carlton Avenue	Willow Road	NB	26	25	25	25
				SB	27	25	27	25
D	Newbridge Street	Carlton Avenue	East of Carlton Avenue	NB	24	25	23	25
				SB	24	25	26	25

**Belle Haven Neighborhood Traffic Management Plan**  
**Vehicular Travel Speeds**

### Belle Haven traffic improvements survey

The City Council previously approved the Belle Haven Neighborhood Traffic Management Plan to address cut-through traffic concerns in the Belle Haven neighborhood through the use of traffic calming measures. In June 2020, the installation of temporary traffic calming measures was completed. This survey is being distributed online and via mail to solicit feedback on making the implemented traffic calming measures permanent.

General questions:

- 1) Check all that apply (*see map below*):
- I rent in the neighborhood
  - I own and live in the neighborhood
  - I own and live outside the neighborhood
  - I own business in the neighborhood
  - Other (please specify) \_\_\_\_\_



- 2) Were you aware of the Belle Haven Traffic Calming Plan before this mailer? (project webpage: [menlopark.org/bellehaventraffic](http://menlopark.org/bellehaventraffic))
- Yes
  - No

3) As part of the plan, temporary bulb outs and a permanent speed feedback sign were installed in June 2020. What type of impacts do you think these changes have made to the neighborhood? *(see photos below)*

- Very positive
- Somewhat positive
- Neutral
- Somewhat negative
- Very negative

Example: Temporary intersection bulbout (Location: Almanor Ave. at Terminal Ave.)



Example: Speed feedback sign (Location: Chilco St. between Hamilton Ave. and Ivy Dr.)





4) In addition to the plan, the City also installed turn restrictions in October 2019 per City Council's request. Did you change your typical driving patterns as a result? *(see map below)*

- Yes
- No
- I don't know
- I don't drive



5) Before the installation of the plan and turn restrictions, cut-through traffic in the Belle Haven neighborhood was:

- A serious problem
- A moderate problem
- A minor problem
- Not a problem

6) What level of benefits do you think these improvements provide for vehicle circulation?

- Significantly more
- Slightly more
- About the same amount of
- Slightly less
- Significantly less

7) Please describe how these improvements have impacted your walking, biking, or driving patterns and behaviors, or provide any other thoughts on these improvements:

---



---



---

Specific measures:

1) Do you think the City should make these bulb outs permanent, like these examples? *(see photos below)*

- Yes
- No
- Neutral

Example: Permanent detached intersection bulbout (Location: Encinal Ave. at Garwood Wy.)



Example: Permanent tradition intersection bulbout (Location: Chilco St. at Hamilton Ave.)



2) If directed to proceed with permanent design, the City will explore the best design option based on existing constrains (e.g., stormwater flow, ADA, etc.) and feedback from residents. Please share your feedback about each of the design shown in **Question 1**, if any.

---

---

---

- 3) Field observations revealed scuffmarks on some of the temporary bulb outs. What should be done at those locations in the permanent design? (*see photos below*)
- Focus on pedestrian safety over vehicle maneuverability (e.g., larger vehicles might occasionally go over the curb when turning)
  - Focus on vehicle maneuverability
  - Neutral

Example: Temporary intersection bulbout (Location: Newbridge St. at Carlton Ave.)



Example: Temporary intersection bulbout (Location: Newbridge St. at Carlton Ave.)

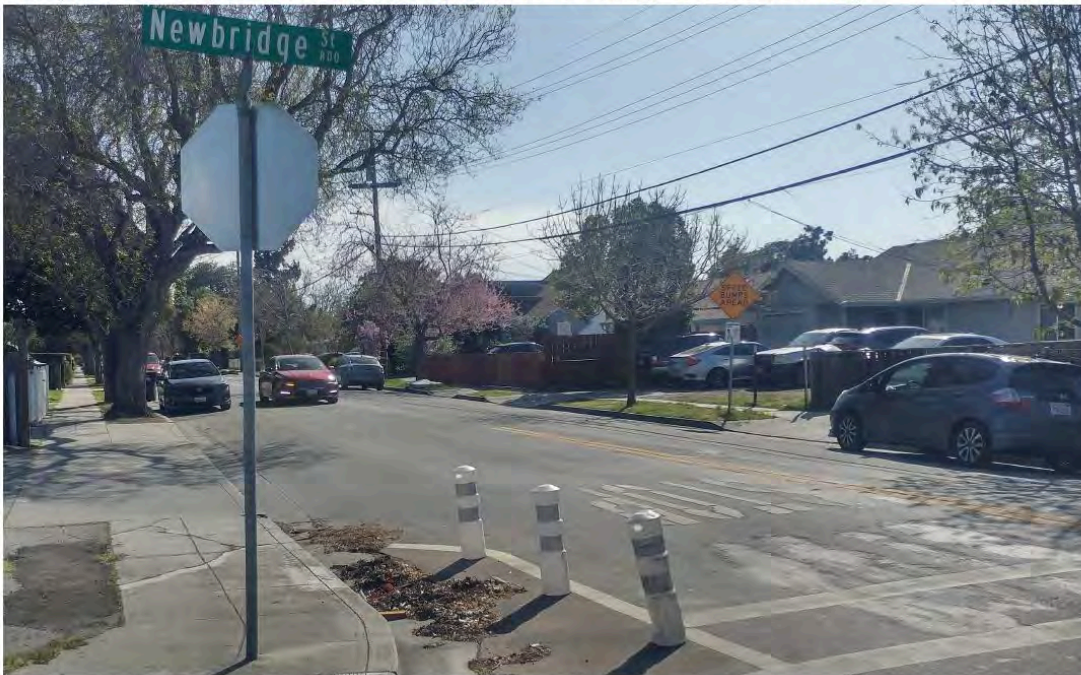

- 4) The plan also included bulb outs on Ivy Drive. Since improvements to Ivy Drive are subject to San Francisco Public Utilities Commission (SFPUC) approval, any bulb outs on Ivy Drive would be constructed using permanent materials without a “temporary” phase. Do you support having permanent bulb outs on Ivy Drive similar to the examples above in **Question 1**?
- Yes
  - No
  - Neutral

- 5) Have you noticed a change in speed on Chilco Street with the new speed feedback signs?
- Increase
  - Decrease
  - No change
- 6) The plan also included a “no right turn on red” sign on eastbound Newbridge Street at Willow Road to come on when northbound Willow Road left turn has a green arrow. The intent is to reduce conflict between vehicles from these two directions at the frontage road entrance and will require Caltrans approval. Are you aware of this improvement? *(see existing and proposed illustrations below)*
- Yes
  - No

Existing signal operation – eastbound Newbridge St. right turn on red is allowed, when northbound left shows a green arrow.



Future signal operation – eastbound Newbridge St. right turn on red is prohibited, when northbound left shows a green arrow.



7) In addition to the improvement described in question 6, please provide any other feedback you might have for the Newbridge Street and Willow Road intersection:

---

---

---

8) Please describe any other feedback you have:

---

---

---

Optional:

Please provide your contact information so that we can keep you informed as the project moves forward.

Name: \_\_\_\_\_

Email: \_\_\_\_\_

Phone: \_\_\_\_\_

Address: \_\_\_\_\_

Zip Code: \_\_\_\_\_

Agenda item L1  
Jacqui Cebrian, resident

I am a member of the Complete Streets Commission, but speaking only for myself. I'm a little surprised to see the staff report recommend going forward with the bulbouts on Newbridge while acknowledging that it forces bicycles into the lane of traffic AT EVERY INTERSECTION along Newbridge where bulbouts are present. This road is a primary thoroughfare for the community and as such has lots of traffic, including buses, garbage trucks and fire trucks. I think it is a very unsafe idea to force bikes to navigate themselves into and out of the flow of traffic in order to solve a problem that isn't really a problem. Newbridge isn't that wide of a street that we need ped protections to shorten it. The bulbouts cause a problem for bikes right now and we should not make the choice to continue increasing their risks on the possibility that someday wider sidewalks will be built. Newbridge also doesn't need speed humps. Those will drastically inconvenience residents while not reducing cut through traffic in any meaningful way. The staff reports will show that speed isn't a big factor on Newbridge. Chilco is the street that could use some speed mitigation elements. Thank you for listening.



# BELLE HAVEN NEIGHBORHOOD TRAFFIC CALMING PLAN – PERMANENT INSTALLATION

City Council Meeting: September 14, 2021

ARRIVEAGA FEMBY  
GYMNASIUM

# AGENDA

- Plan milestones
- Implementation process
  - Data collection
  - Survey results
- Recommendations
- Next steps





## PLAN MILESTONES

- Aug. 2019
  - City Council approved Plan
- June 2020
  - Trial measures installed
- Mar. 2021
  - Permanent installation implementation process revised
- Aug. 2021
  - Complete Streets Commissions (CSC) recommended permanent installation

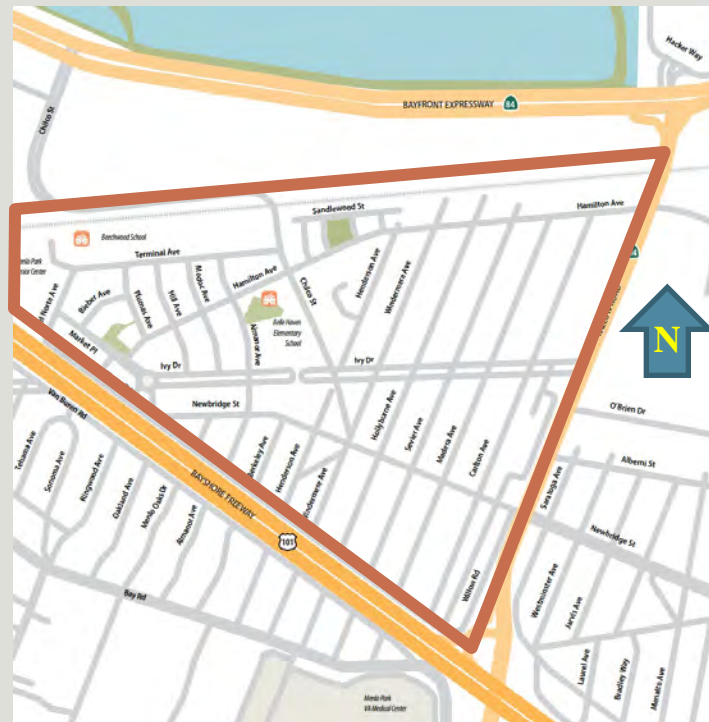

# REVISED IMPLEMENTATION PROCESS

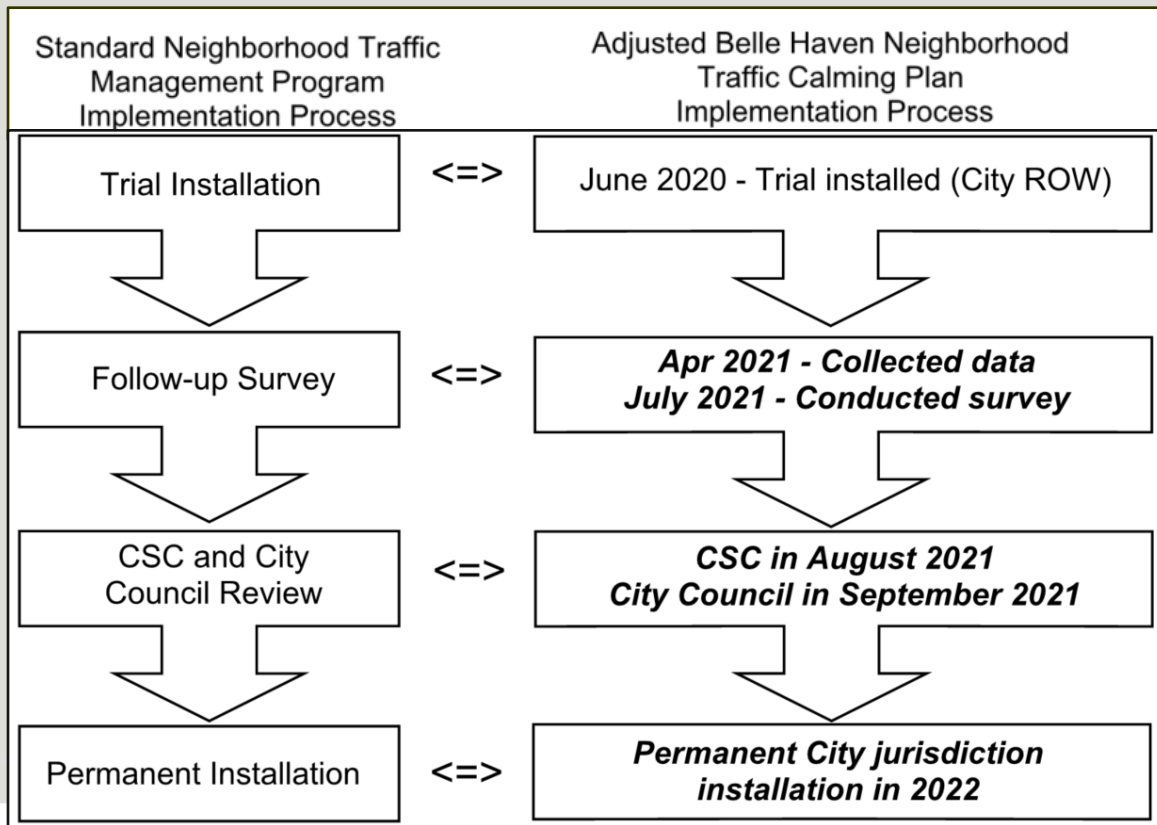

# DRAFT PLAN



Right-of-Way  
Approval Authority

City

San Francisco Public  
Utilities Commission

Caltrans

# SURVEY RESULTS – SPEED LIMIT SIGNS

- Speed reduction effectiveness (83)
  - increase: 4%, decrease: 24%, no change: 72%

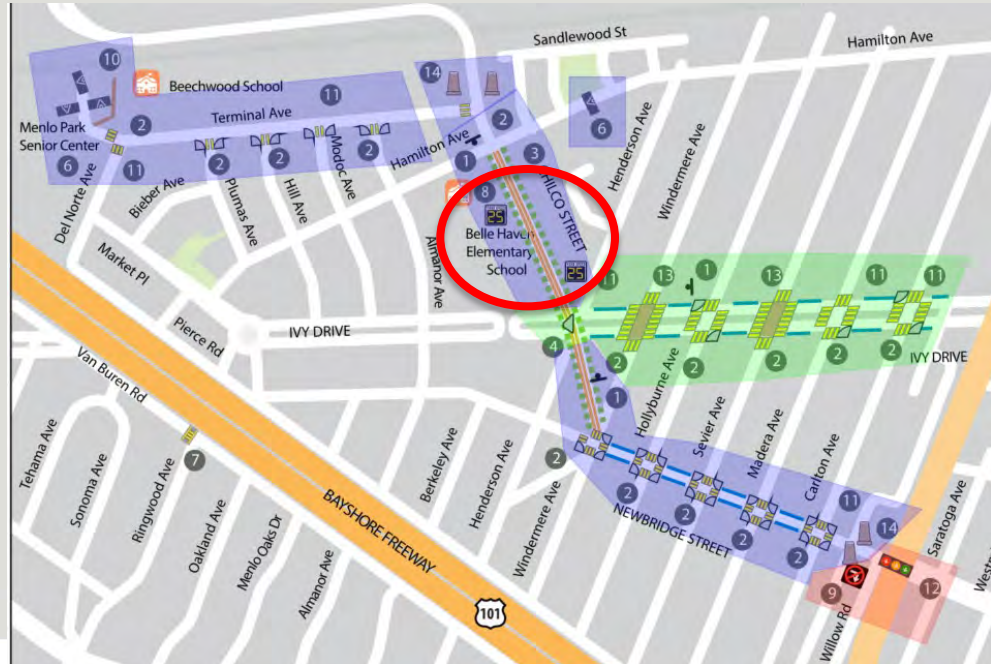

## SURVEY RESULTS – BULBOUTS (CITY ROW)

- Permanent installation (82)
  - Support: 52%, oppose: 32%, neutral: 16%
- Designs should focus on (89):
  - Pedestrian access/safety: 57%, vehicular access/maneuverability: 22%, neutral: 21%
- Bulbout design style: traditional vs. detached



Traditional



Detached

# SURVEY RESULTS – WILLOW RD. / NEWBRIDGE ST. (CALTRANS)

- a. Reverse Newbridge St. signal phase sequence
- b. Convert Newbridge St. left turn to a protected phase
- c. Prohibit Newbridge St. right turn when Willow Rd. eastbound left is activated (84): weekdays from 4 to 6 p.m.
  - Modification awareness: 33% yes, 67% no
  - Concern: longer congestion on Newbridge St. during the morning peak hours

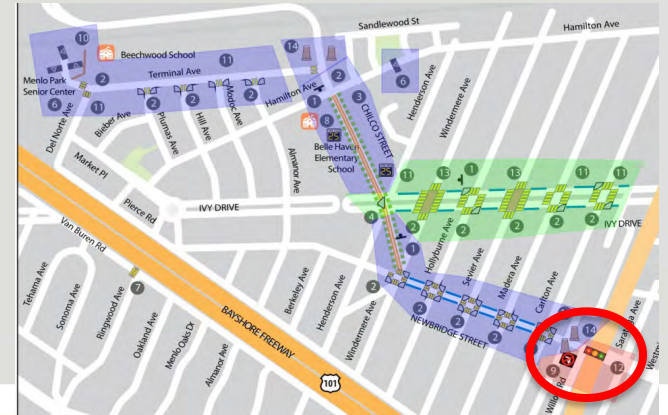

# SURVEY RESULTS – IVY DRIVE (SFPUC)

- Bulbouts, crosswalks/nose medians (84)
  - Support: 49%, Oppose: 26%, Neutral: 25%



Existing



Proposed:  
Crosswalk/  
nose median

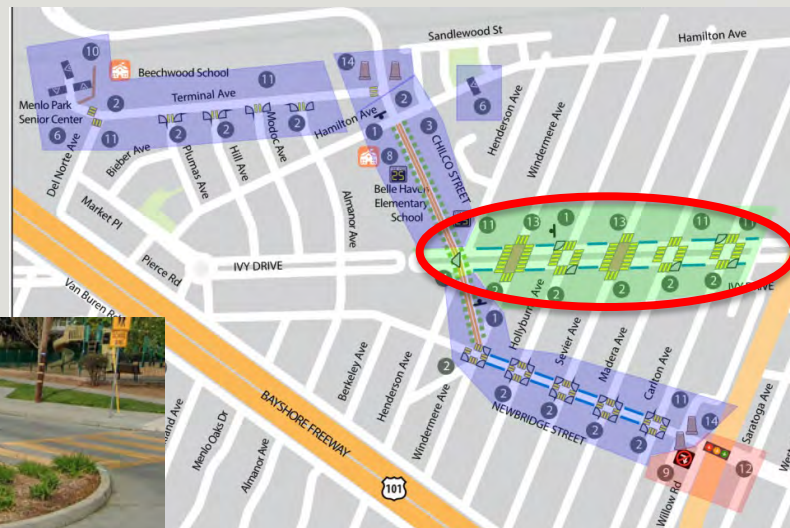

## NEWBRIDGE ST. BULBOUTS

- Slow down right turning vehicles
- Shorten crossing distance
- Less confident bicyclists may experience discomfort sharing space with vehicles at intersections





# PLAN COMPARISON



Recommended Plan



## RECOMMENDATIONS

- Permanent installation
  - Chilco St.: speed feedback signs
  - Newbridge St. and Hamilton Ave: gateways
  - Terminal Ave. and Newbridge St. cross streets: bulbouts
  - Willow Rd. / Newbridge St.: signal improvements
    - c. No right turn blank out sign: weekdays 4 – 6 p.m.
  - **Newbridge St.: bulbouts**
  - **Ivy Dr.: substitute bulbouts/raised intersections with median noses**

# RECOMMENDED PLAN



Right-of-Way  
Approval Authority

City

San Francisco Public  
Utilities Commission

Caltrans

## NEXT STEPS

- Incorporate City Council direction
- Commence steps for final design and implementation



**THANK YOU**



**STAFF REPORT**

**City Council**

**Meeting Date:**

**9/21/2021**

**Staff Report Number:**

**21-182-CC**

**Regular Business:**

**Authorize the city manager to reactivate the gymnastics program**

**Recommendation**

Staff recommends that the City Council:

1. Direct staff to reactivate the gymnastics program starting in November 2021
2. Authorize 5.75 full-time equivalent (FTE) employees to support gymnastics program operations, consistent with program staffing levels in fiscal year 2018-19
3. Amend the fiscal year 2021-22 operating budget to include \$767,000 total budgeted expenditures and \$450,000 total projected revenues for gymnastics program operations.

**Policy Issues**

City Council sets policy and goals and provides direction to staff regarding municipal services to the Menlo Park community; and allocates resources to support and maintain city facilities and operations and provide services to residents.

**Background**

City-owned facilities were closed to indoor public access March 12, 2020, due to the COVID-19 pandemic. This precaution was necessary to protect public health by minimizing opportunities for congregation, both by the public and employees. Due to the infeasibility of safely delivering gymnastics services during the COVID-19 pandemic, City Council suspended the gymnastics program operations in the fiscal year 2020-21 operating budget and eliminated all gymnastics staff positions.

**Analysis**

In conjunction with the fiscal year 2021-22 budget adoption process, City Council June 22, 2021, directed staff to prepare a proposal to reactivate the gymnastics program using city personnel, on a timeline consistent with the City's four-phase reopening plan (Attachment A.)

Since March 2021, staff has received unsolicited inquiries from over one hundred gymnastics program families inquiring about reactivation plans and expressing their interest in returning to Menlo Park's gymnastics program.

Phased-in reopening

COVID-19 vaccines allowed the city to plan for reopening facilities to indoor public access in the foreseeable future. However, concerns about the delta variant and the recent surge in COVID-19 cases calls for a cautious approach to reopening facilities to indoor public access and high-contact activities. It is uncertain how long the pandemic will continue to adversely impact program operations going forward, and it

is not yet known to what extent the pandemic has permanently altered people's interests and habits as they pertain to recreation and athletics program participation. For these reasons, staff has prepared a proposed plan and timeline that includes a conservative, phased approach for reactivating the gymnastics program.

- Phase 1: November 2021
  - Weekday operations focused on children/toddlers and special needs
- Phase 2: January 2022
  - Expand to weekday evening operations including competitive/adults
- Phase 3: March 2022
  - Expand to seven-day operations including weekend programs and facility rentals.

Staff recommends an initial schedule starting in November 2021 and focused on programs for young children and those who have special needs. The initial operating schedule would be Monday through Friday from 9 a.m. to 6 p.m. Classes would be scheduled for 45-minutes on each hour allowing for 15-minutes in between each class to clean and wipe down the gymnastics equipment. A majority of these classes would be offered to children ages one to six years. Additionally, classes would be offered to participants of different levels of experiences including beginning, intermediate and advanced levels for children of all ages and abilities. Staff would evaluate the first two months of program operations and increase capacity with the goal of expanding to weekday evenings in January 2022 with competitive gymnastics for older children, youth and adults; and to seven-day operations in March 2022 with weekend classes and facility rentals (Attachment B.)

#### Personnel capacity

Prior to the pandemic and public health closure of the Arrillaga Family Gymnastics Center, the City of Menlo Park's gymnastics program operated seven days, 58 total hours per week, and employed 5.75 FTE regular benefitted employees and approximately 40-50 temporary employees.

All regular and temporary gymnastics staff positions were eliminated in the fiscal year 2020-21 budget resulting in layoffs. In accordance with collective bargaining agreements and to address personnel needs in other areas, several of the affected gymnastics program employees were and continue to be retained in temporary employment capacities within the library and community services department. These employees combined possess 60+ cumulative years of service to the Menlo Park community. Some joined the program as children decades ago, then joined the City gymnastics staff as adults. Some of these employees have taught multiple generations of families in the Menlo Park community. These employees are available to be rapidly reassigned to the gymnastics program, should City Council authorize the recommended staff positions and program reactivation.

To safely reactivate the gymnastics program, staff recommends that City Council authorize 5.75 FTE regular benefitted positions and expenditures for temporary and seasonal staff, which is consistent with fiscal year 2018-19 gymnastics program staffing levels (Table 1.)

Table 1: Recommended new benefitted staff positions in fiscal year 2021-22		
Classification	FTE	Duties
Recreation Coordinator	1	Coordinate and oversee gymnastics center
Program Assistant	1	Administrative support
Program Assistant	1	Program support and teach classes
Gymnastics Instructor	1	Teach classes
Gymnastics Instructor	1	Teach classes
Gymnastics Instructor	0.75	Teach classes
<b>Total</b>	<b>5.75</b>	

Proposed operating expenditures and revenues

Staff analyzed operating budget actuals from previous fiscal years as reference points to develop proposed program expenditures and revenues for fiscal year 2021-22. The proposed expenditure budget in Table 2 includes annualized expenditures for benefitted staff, factors in partial year operations for other expenditures, and accounts for operational changes over the course of the phase-in timeline. The revenue projections in Table 3 are very conservative to account for a partial year of operations and uncertainty around potential impacts of the COVID-19 pandemic on program attendance going forward.

Table 2 shows proposed salary/benefit expenditures totaling \$610,000 in fiscal year 2021-22. Of this amount, approximately \$511,000 are the annualized costs of the recommended 5.75 FTE benefitted staff positions. This annualized amount reflects a full twelve months of expenditures. Actual year-end salary/benefit expenditures for benefitted staff in fiscal year 2021-22 are projected to be approximately sixty percent of the annualized amount because the program would not start until five months after the fiscal year began.

Additionally, the proposed fiscal year 2021-22 salary/benefit expenditures in Table 2 include \$99,000 for temporary personnel expenditures which factors in a partial year of operations and is not annualized.

Overall, the proposed expenditure and revenue budget projects a cost recovery rate of approximately 80 percent at the end of fiscal year 2021-22, when partial year actual expenditures for benefitted staff are factored in.

Table 2. Gymnastics program expenditures					
	Fiscal year 2017-18 actual	Fiscal year 2018-19 actual	Fiscal year 2019-20 actual	Fiscal year 2020-21 actual	Fiscal year 2021-22 proposed
Salaries/Benefits	\$771,645	\$848,645	\$904,824	\$85,384	\$610,000*
Operating expenses	\$149,979	\$214,669	\$158,838	\$0	\$107,000
Contract services	\$63,904	\$54,642	\$41,565	\$0	\$26,000
Other (utilities, etc)	\$47,947	\$48,890	\$32,477	\$0	\$24,000
<b>Total</b>	<b>\$1,033,475</b>	<b>\$1,166,666</b>	<b>\$1,137,703</b>	<b>\$85,384</b>	<b>\$767,000</b>

\*The proposed fiscal year 2021-22 salary/benefit expenditures for benefitted staff are annualized. Actual year-end salary/benefit expenditures for benefitted staff are projected to be approximately sixty percent of the annualized amount in fiscal year 2021-22, because the proposed program reactivation and associated expenditures, if approved by City Council, would not begin until approximately five months after the start of the fiscal year.



**Table 3. Gymnastics program revenues**

	Fiscal year 2017-18 actual	Fiscal year 2018-19 actual	Fiscal year 2019-20 actual	Fiscal year 2020-21 actual	Fiscal year 2021- 22 proposed
Revenues (fees, etc.)	\$1,741,451	\$1,257,112	\$960,719	\$0	\$450,000
<b>Total</b>	<b>\$1,741,451</b>	<b>\$1,257,112</b>	<b>\$960,719</b>	<b>\$0</b>	<b>\$450,000*</b>

\* The fiscal year 2021-22 revenue projections are very conservative; the projections factor in partial year operations, phased-in reactivation, and uncertainty about the potential ongoing impacts the COVID-19 pandemic may have on program participation going forward.

**Facility preparations and operations**

In addition to the personnel needs, some facility preparations will be required prior to reopening the Arrillaga Family Gymnastics Center facility. This includes but is not limited to signage, air filter replacements, steam cleaning/deep cleaning, and equipment repairs/testing. Facility maintenance and operating costs such as utilities and janitorial service also would be necessary to reactivate. These costs are factored into the proposed expenditure budget shown in Table 2 and are not annualized.

**Impact on City Resources**

If authorized by City Council, the fiscal year 2021-22 budget will be amended to include \$767,000 total budgeted expenditures including 5.75 FTE new benefitted staff positions, and \$450,000 total projected revenues. Because the program expenditures would not begin until approximately five months after the start of the fiscal year, staff estimates that year-end salary/benefit expenditures for benefitted staff are projected to be approximately sixty percent of the annualized amount. Projected revenues are conservative to account for partial year operations, phased-in reactivation, and uncertainty regarding the potential ongoing impacts the COVID-19 pandemic may have on program participation. Overall, the proposed expenditure and revenue budget projects a cost recovery rate of approximately 80 percent at the end of fiscal year 2021-22, when partial year actual expenditures for benefitted staff are factored in.

**Environmental Review**

This action is not a project within the meaning of the California Environmental Quality Act (CEQA) Guidelines §§ 15378 and 15061(b)(3) as it will not result in any direct or indirect physical change in the environment

**Public Notice**

The Parks and Recreation Commission on August 25, 2021 reviewed the proposal to reactivate the gymnastics program (Attachment C.) Public notification was achieved by posting the agenda, with the agenda items being listed, at least 72 hours prior to the meeting.

**Attachments**

- A. Hyperlink – City of Menlo Park reopening plan: [menlopark.org/reopening](http://menlopark.org/reopening)
- B. Description of classes
- C. Hyperlink – Parks and Recreation Commission meeting agenda, August 25, 2021: [menlopark.org/AgendaCenter/ViewFile/Agenda/\\_08252021-3664](http://menlopark.org/AgendaCenter/ViewFile/Agenda/_08252021-3664)

Staff Report #: 21-182-CC

**Report prepared by:**

Theresa N. DellaSanta, Interim Assistant Community Services Director

Karen Mihalek, Recreation Coordinator

**Report reviewed by:**

Sean S. Reinhart, Library and Community Services Director

## GYMNASTICS - DESCRIPTIONS OF PROPOSED CLASSES

City of Menlo Park gymnastics instructors are often the very first teacher to in a young child's life. Gymnastics instructors teach the fundamentals vestibular stimulation, bilateral movement, and motor mapping to children of all ages and abilities. These skills help to aid in balance, tracking with the eyes, and body space awareness and eye hand eye foot coordination. All these perceptual motor skills are an important part of a child's development.

City of Menlo Park gymnastics staff are often specifically sought out by families for their experience in teaching gymnastics, and in particular their personal experience with teaching and nurturing special needs children. The staff take a gentle approach to teaching children and allow each child to learn at their own pace. Some of the children go on to competitive gymnastics and Menlo Park staff have extensive experience preparing children for competition if they and their families desire it, however no child is pressured to increase their involvement in gymnastics beyond what they and their families are prepared to invest. This child-centered approach is a special attribute of the City of Menlo Park's gymnastics program compared to the competition-driven programs run by many private sector operators.

**Kindergym:** A caregiver and child participation class, ages walking to 3 years of age. Kindergym is a loosely structured class designed for children to socialize with their peers, experiment with movement on different surfaces, and explore different ways to move through the environment. This is a great class to teach your child how to safely climb and walk on uneven surfaces (bilateral movement and motor mapping).

**Kinderstars:** A caregiver and child participation class, ages 2.5 to 4 years of age. Kinderstars introduces the first level of instruction. Students will learn to stand in line, be given a short set of directions and take turns on equipment. Children will also learn how to work in groups with their caregiver during parachute activities. We will work on listening skills, rolling, hanging, walking on uneven surfaces, and jumping.

**Newstars:** An independent class for 3-4 year olds. Children are given short sets of directions and work in circuits to practice and learn different types of rolls, be introduced to handstands and cartwheels, and work on gymnastics equipment that is at the proper height for their age and size. Balance, strength and coordination are worked on in this class.

**Ministars:** An independent class for ages 4 to 5. Children will be working in circuits to hone their skills and develop strength. Children will continue working on handstands and cartwheels (these skills are connected and require strength and balance), more difficult bar skills (introducing pull overs and front supports), forward and backward skills on low balance beams. Direction following, listening skills and turn taking are also part of the class.

**Superstars:** An independent class for ages 5 to 6. Children will continue to improve the skills they learned in NewStars and MiniStars. They will learn to connect skills and some will be able to perform the skills with little or no help. The class still works on the obstacle courses but different skills are introduced into the course. Children will be working on forward and backward skills on both the floor and balance beams.

**Level A:** Beginning level of gymnastics. Open to students with no or little experience in the sport. The student will work on all the Olympic apparatuses, the boys will work on the parallel bars, rings, floor and vault (these take a great deal of strength so the boys spend a good deal of time working on coordination and strength activities); the girls will be on the balance beams, uneven bars, vault and floor. Strength work and basic skills will be worked on in these classes.

Level B: Intermediate level of gymnastics. Students must pass Level A in order to register for the class. Children will build on the skills they have learned in Level A. They will also learn move difficult floor exercise skills for example round offs, back walkovers; back hip circles on bars and connecting moves on the uneven bars; also connecting moves on the balance beams.

Level C: Advanced level of gymnastics. Must pass Level B in order to be in the class. Will work on skills such as back extension rolls, back walkovers, and back handsprings. More difficult moves will also be worked on the uneven bars and vault. Connecting moves and working them into a sequence of a short routine will be part of the class.

Strength and Conditioning: Designed to work skills to strengthen core muscle groups. Also designed for gymnasts interested in competitive gymnastics and former competitive gymnasts interested in regaining strength and flexibility in order to compete in later seasons. The class will be designed to work on areas that are needed by the group of participants.

Special Needs Class: This class is for children that need additional help to participate in a class. The class will be a caregiver and participant class. Participants and their caregiver will work on the equipment to learn rolls, work on balance, flexibility and motor mapping. We will also work on hanging on equipment to strengthen hand grip and arm strength. Simple directions will be given to caregivers to help the child perform the skill with their assistance.

Sensory Class: Children will be pouring, molding and manipulating different types of surfaces and materials. Please let us know if your child has a sensitivity to an item as we will be using flour, salt, cornstarch, water, food coloring and other items of this nature. We will get messy in some of the classes- the teacher will send out a warning the day or two before the class if this is the case. We will also be using items that make different types of noise. The class is designed to stimulate different senses and encourage exploration.

## Agenda item L2 Michael Taylor, resident

Good evening, Mayor Combs and City Council, my name is Michael Taylor. I live at 180 Seminary Drive; I've lived in Menlo Park for almost 30 years. Thank you for the opportunity to speak today and thank you for your service to our community.

First, I'd like to tell you a little bit about myself. I am a USA Gymnastics National Instructor and have been since 1984. USA Gymnastics is the national governing body for the sport of gymnastics. I've been all over the country teaching safety and technique classes, conducting seminars and clinics for coaches, teachers, and parents, and running camps and events for athletes. I've served as expert witness in over 100 legal cases and lawsuits. Gymnastics is the foundational basis for all movement and sport activities. It is crucial for children to have access to a professional, quality, developmental gymnastics program. If you need more information on my credentials and qualifications, please check out my website at gym.net. The point is, I know gymnastics.

More importantly, I know Menlo Park. My two youngest children went through the Menlo Park school system, and they participated in many of the recreation programs offered in Menlo Park, including dance, AYSO, martial arts, Little League, swimming, and gymnastics. I worked for the city for 17 years, including many years running the gymnastics program. When I arrived in 1991, there were about 200 students in the program and in a few short years, my staff and I grew the activity to over 1,700 participants. In 2005, I was the Interim Director of the Community Services Department. I left the city in 2007 and went to work for the City of Saratoga, a community of about 33,000 people, very similar to Menlo Park, where I ran the Recreation and Facilities Department and the Risk and Emergency Management programs for 12 years. I retired a little over two years ago after 30 years in City government; I understand municipal government.

I am here to encourage the Council to NOT reinstate the city-operated Gymnastics Program as outlined in the staff report. As a taxpayer I consider the additional cost to the city to be exorbitant and totally unnecessary. It is crucial that a city the size of Menlo Park provide a high-quality gymnastics program for the youth, but there are many ways to accomplish this and conducting a city-run program is only one. In 2006, after Burgess swimming pool had been closed for renovation, as Interim Community Services Director, I recommended that City Council contract the Aquatics program to an outside provider for an immediate cost savings to the City of \$1.3. We avoided the need for recruiting and hiring lifeguards, pool managers, desk staff, and provide trainings, and transferred that responsibility to an independent contractor who, to my knowledge, has done an outstanding job of providing a safe, comprehensive aquatics program to the city. That contract arrangement remains to this day and continues to be a successful community program. It is an excellent example/model of what I recommend. If the Council approves a similar arrangement for the gymnastics program, an independent contractor can provide a quality service without burdening the city with an additional 5 ¾ FTE's. I encourage you to talk to the finance department about the true costs of employees, especially other post employment benefits (OPEB) packages and the ongoing financial burden those place on the city. There is no need to add additional employees when the City can contract out the program, receive better services with better staffing, and without additional costs. The truth of the matter is the city is not positioned to offer a quality program. The bureaucracy and difficulties of recruiting, hiring, training, and certifying qualified gymnastics instructors, scheduling, and paying them appropriately is simply not possible in a city-run program. It is possible with direct leadership that could be provided by an outside provider.

There are many examples of the advantages of "out-sourcing" services. The City of Saratoga Recreation Department provided over 220 classes, camps, and activities by using 61 independent contractors for everything from dance to soccer to swimming and childcare, providing quality services to the residents that met the standards established by the City. Each contractor provided the City with a two-million-dollar certificate of primary insurance, reducing liability for the City. The entire Saratoga Recreation Department operated with just two staff (Program Coordinators).

This is a golden opportunity to do the right thing. SEIU may have concerns, but the gymnastics positions are currently vacant, and any previous staff members would have the opportunity to apply for new positions with an independent provider. The city could prepare an agreement that is financially beneficial and would ensure the program meets the standards it deems appropriate for a comprehensive, quality gymnastics program.

Please do not recommend reinstating the city-run gymnastics program. I suggest the Council prepare an RFP to find a professional independent contractor that can provide the service, save the City substantial amounts of money, reduce liabilities, and provide a truly quality program that includes recruitment of qualified individuals, hiring sufficient staff, offer extensive training, and create a safe, quality, comprehensive program. I ask that the Council re-open the gymnastics program but NOT reinstating the city-operated activity.

That concludes my comments, but I am available to answer any questions you may have, and please feel free to contact me anytime.

Sincerely Yours,

Michael Taylor  
180 Seminary Drive  
650-888-9020 | coacht@gym.net

p.s

I highly recommend that all members of Council read "Reinventing Government" by David Osborne, former City Manager in Redwood City.

## Agenda item L2

### Nancy Wagner, resident

My name is Nancy Wagner. I am concerned about the City Council rushing to rubber stamp the City Staff's proposal to reopen the gymnastics program without first conducting a review of how a City run gymnastics program will be funded, why it's subsidized by taxpayers and if a private vendor could better meet the needs the community with improved programming, including more class offerings for gymnasts of all levels and abilities.

My interested in gymnastics goes back to the days when I was a competitor, coach and even a teacher for the City of Menlo Park gymnastics program in the 1980s. I later participated in the adult class taught by Michael Taylor. I am married to a former City of Menlo Park gymnastics employee, our son was in preschool gymnastics programs and team programs at Burgess.

As someone who uses the sports facilities at the City of Menlo Park, and is an avid swimmer, I've come to appreciate how turning over the pool to a private contractor was one of the best decisions the Council made.

The Council rejected City Staff's recommendation to have the City resume operations and instead choose to go with the more successful and fiscally advantageous option for the City residents when voting to contract the program to a private vendor with a stellar track record.

At the time that decision was finalized, the pool had been closed for about 2 years, and City pool employees had already been reassigned to other departments or found other employment. Here is the opportunity for our City Council to do the same for Gymnastics.

Due to the closure of the Gymnastics program for almost 2 years now, the City Council is again presented with a unique opportunity that could improve operations.

I ask that the Council pause any decision on approving City staff report that includes the hiring of 6 City funded positions until options are considered, taking into account the fiscal savings to the taxpayers and the ability of a private vendor to reopen a more vibrant and fully operational program.

I would hope that the Council consider that the City managed gymnastics program, in 2018 and prior to Covid, eliminated birthday parties and cut programming by 25 percent.

Nothing in the City staff report addresses how this City operated and managed sports program would address the issue of staffing the program adequately enough to provide a high quality program with full class offerings.

With the exception of gymnastics, all other sports programs offered through the city recreation department are already contracted out, quite successfully.

It's one thing for the City to subsidize and run the City operated childcare program, for example, which is providing an essential service to the community.

Sports activities like Gymnastics should be treated like the Aquatics program - and all other sports programs - and be operated for the City of Menlo Park by private vendors.

The City Council would be premature in approving the City staff's proposal at this juncture, and until the fiscal realities and program options are examined.

Agenda item L2

Louise Furukawa, resident

My child, now a college student had the opportunity to train and compete at the highest level of boy's/men's gymnastics having started at this facility. When the boy's program closed, we were forced to commute 1.5 hours daily to an appropriate gym at his level. It is very difficult to find qualified coaches for boys in gymnastics and the majority of his former coaches are now at Goldstar. Menlo Park has the opportunity to insert highly qualified coaches with a proven performance record into it's coveted facility.

Agenda item L2  
Sandy Lee, resident

Please reactivate the city run gymnastics program. My daughters have actively participated for many years (one was on the team for 7 years up to Level 7). The coaches, teachers, and staff make this program very special. They run a program that is healthy, fun, safe, and developmentally appropriate. Whereas a private gym rather focuses on money and competition. Please bring back our beloved city run gymnastics program!



# Agenda item L2

## Pamela Evans

To the Menlo Park City Council,

My name is Pamela Evans, and I have owned Gold Star Gymnastics since 2001. In these turbulent times, I am writing to offer a proposal. If the City of Menlo Park is considering contracting a third party to manage the gymnastics program, I would be interested in discussing this possibility. Menlo Park Gymnastics has been a mainstay in our area for decades, and we would like to assist in whatever way possible to make sure that the program continues.

### Staffing:

We are uniquely suited to such an arrangement. Over the years Gold Star and Menlo Park Gymnastics have shared many staff members. Currently we have several employees who began their career at Menlo Park Gymnastics and have now moved to Gold Star. If we were to be awarded this contract, we would encourage Menlo Park Gymnastics coaches who were employed in March, 2020, to interview. We are always looking for experienced staff, and offer highly competitive rates of pay plus full benefits for any employees scheduled for 25 hours per week (including health and dental insurance, vacation and holiday pay, and a retirement fund). We have had a wonderful record of hiring high quality coaches who formerly worked for Menlo Park Gymnastics because our philosophies are so similar.

Like Menlo Park, Gold Star strives to structure a curriculum for all students, from those who simply feel that their lives will be enriched by learning cartwheels to those who want to test their skills on a competitive stage. Yet even with our competitive program we cherish family and childhood. Our schedules maximize practice times that are non-school nights while keeping family dinners intact as much as possible. In all of our classes, we offer high quality instruction in an inclusive, supportive, and safe environment.

We are committed to providing the same caring and attentive training for our coaches. Our extensive staff development assures that all of our teachers feel confident when leading their own classes, which translates directly to the children feeling successful while participating in these classes. We employed more than 30 full time and 90 part time staff.

Over 50 part time employees are high school students, who live within a 10 mile radius of the gym. We would continue with this practice in Menlo Park. We pride ourselves on training young coaches to become kind and effective teachers while also becoming good employees. These young coaches learn how to be responsible for the health and well-being of their students, to teach progressions to beginners, to interact respectfully with their co-workers, along with a multitude of other benefits. They are placed in charge of a class of children and tasked with not only keeping them safe but helping them to learn and advance all while having fun. We would not just provide exercise for the youngest Menlo Park residents, but also a first job for the City's teenage population.

### Class Offerings:

Our company serves approximately 2500 students attending per week in non-competitive classes for all skill levels including Parent & Tot, PreSchool & School-Age Gymnastics Classes, and Ninja. Our competitive program consists of Boys and Girls Competitive Gymnastics Teams, and All-Star Competitive Cheer Teams. Throughout the year we also offer School-Holiday Camps, Birthday Parties, and Kids Night Out Parties.

We also offer many options for children with special needs. We encourage children impacted by physical, mental, and cognitive challenges to join our regular classes. If the child needs an aide, we can assign a coach-in-training to help with the class, thereby offering an extra hand or to present modified exercises. We also allow personal aides on the gymnastics floor to assist the child in staying focused, interacting positively with their classmates, and finding success in our curriculum. For those students who need even more attention, we offer private lessons. Over the last 10 years we have employed three staff members who completed graduate degrees in Occupational Therapy and work specifically with youth populations. All three of these coaches are also expert gymnastics instructors and have provided our staff with guidance, through clinics and daily mentoring of teaching methods for specific children in their classes. One of these coaches is currently employed part time with Gold Star, one has expressed an interest in returning if we are awarded this contract with Menlo Park gymnastics and is currently running a company offering therapy through gymnastics to children with exceptionalities and/or disabilities, and the third lives locally and continues to give expert advice to Gold Star.

## Agenda item L2 Pamela Evans, continued

### Scholarship Opportunities:

We have extensive scholarship opportunities in place at Gold Star. Every one of our employees is given an employee discount which they can extend to members of their own family, or a family of their choosing. This discount provides classes at an enormous reduction. Also, those high school coaches who are members of our competitive teams receive a discounted rate. And of course, we do award special rates for families in need.

In addition to all of these reduced tuition rates, we are committed to researching other non-profit opportunities to supplement tuition for underserved communities in the City. In past years, Gold Star taught satellite programs in preschools. We would be happy to discuss offering classes at the Belle Haven Center if this arrangement would bring gymnastics into underserved communities.

### COVID Safety Protocols:

In June, 2020, we re-opened summer camps and teams, and added classes in July 2020. Over the last year we have constructed the safest possible environment for our students. Below are just some of the procedures that were implemented.

- We set separate entrances and exits to avoid overcrowding in the lobby.
- We added handwashing stations outside the front doors in addition to the bathrooms, to ensure that every student can wash their hands before and after class.
- We gave every student a string backpack to carry their shoes and water bottles from event to event. Our cubbies and drinking fountains are no longer being used (except for filling water bottles).
- We installed bleachers outside of our large picture windows to give spectators the ability to social distance while watching classes. We began allowing parents in the building in June, 2021, as long as they are fully masked.
- We rearranged the gymnastics equipment and mapped each event to accommodate adequate space for every student.
- We altered the class schedules so that equipment can be cleaned every hour; and hung buckets with spray bottles filled with child-safe disinfectant and washcloths to provide immediate access for cleaning at each event.
- We increased ventilation by powering the retractor fans on the roof, replacing the air conditioning filters with HEPA filters, and opening the five sets of doors throughout the building.

If such an opportunity arises to bring in a third party to take over the gymnastics program, I sincerely hope that you will consider us.

Sincerely,

Pamela Evans, PhD



# GYMNASTICS PROGRAM REACTIVATION

Theresa DellaSanta, Interim Assistant Community Services Director  
Karen Mihalek, Recreation Coordinator

A close-up photograph of the brick facade of a building. The text "ANNIEERGA FAVELY GYMNASIUM" is visible on the brickwork, with "ANNIEERGA FAVELY" on the top line and "GYMNASIUM" on the bottom line. The brick is a reddish-brown color, and the text is in a dark, possibly black or dark brown, font.

ANNIEERGA FAVELY  
GYMNASIUM

# RECOMMENDATIONS

- Direct staff to reactivate the gymnastics program starting in November 2021
- Authorize 5.75 full-time equivalent (FTE) employees to support gymnastics program operations, consistent with program staffing levels in fiscal year 2018-19
- Amend the fiscal year 2021-22 operating budget to include \$767,000 total budgeted expenditures and \$450,000 total projected revenues for gymnastics program operations.



## BACKGROUND

- COVID-19 pandemic and economic recession
- City-owned facilities closed to indoor public access March 12, 2020
- Due to infeasibility of safely delivering gymnastics services during the pandemic, City Council suspended the gymnastics program in the FY 2020-21 budget and eliminated gymnastics staff positions
- COVID-19 vaccines in 2021 allowed the city to plan for reopening facilities
- On June 22, 2021, City Council directed staff to prepare a proposal to reactivate the gymnastics program using city personnel
- Since March 2021, staff has received unsolicited inquiries from over one hundred gymnastics program families inquiring about reactivation plans and expressing their interest in returning to Menlo Park's gymnastics program

## PHASED-IN REOPENING

Concerns about the delta variant and uncertainty about the long-term impacts of the pandemic indicate a conservative, phased approach for reactivating the gymnastics program:

- Phase 1: November 2021
  - Weekday operations focused on children/toddlers and special needs
- Phase 2: January 2022
  - Expand to weekday evening operations including competitive/adults
- Phase 3: March 2022
  - Expand to seven-day operations including weekend programs and facility rentals.

*All dates are tentative and subject to change*



# YOUTH AND SPECIAL NEEDS



- A resource for children of all ages and abilities
- Experiment and experience the joy of movement
- Build strength and coordination which also supports math and language skills
- Progression to competitive classes if that is their goal
- Opportunities to compete and train at a higher level
- Taught by our experienced and compassionate staff who have familiarity in teaching children of all ages and abilities.



## PERSONNEL CAPACITY

- To safely reactivate the gymnastics program, staff recommends that City Council authorize 5.75 FTE regular benefitted positions and expenditures for temporary and seasonal staff, consistent with FY 2018-19 staffing levels

Position	FTE	Duties
Recreation Coordinator	1.00	Coordinate and oversee gymnastics center
Program Assistant	1.00	Administrative support
Program Assistant	1.00	Program support and teach classes
Gymnastics Instructor	1.00	Teach classes
Gymnastics Instructor	1.00	Teach classes
Gymnastics Instructor	0.75	Teach classes
Total	5.75	



## OPERATING REVENUES AND EXPENDITURES

- Staff analyzed operating budget actuals from previous fiscal years as reference points to develop proposed program expenditures and revenues for fiscal year 2021-22
- Factor in partial year operations, phase-in timeline
- Revenue projections that reflect the uncertainty of the impacts the COVID-19 pandemic may have on program attendance.





# FISCAL YEAR 2021-22, EXPENDITURES PROJECTIONS

- Salaries/benefits for benefitted staff are approximately \$511,000 and are annualized; actuals are projected at 60% due to partial year operations
- Salaries/benefits includes \$99,000 for non-benefitted temporary personnel, not annualized

Table 2. Gymnastics program expenditures

	Fiscal year 2017-18 actual	Fiscal year 2018-19 actual	Fiscal year 2019-20 actual	Fiscal year 2020-21 actual	Fiscal year 2021-22 proposed
Salaries/Benefits	\$771,645	\$848,645	\$904,824	\$85,384	\$610,000*
Operating expenses	\$149,979	\$214,669	\$158,838	\$0	\$107,000
Contract services	\$63,904	\$54,642	\$41,565	\$0	\$26,000
Other (utilities, etc)	\$47,947	\$48,890	\$32,477	\$0	\$24,000
<b>Total</b>	<b>\$1,033,475</b>	<b>\$1,166,666</b>	<b>\$1,137,703</b>	<b>\$85,384</b>	<b>\$767,000</b>



# FISCAL YEAR 2021-22, REVENUES PROJECTIONS

- Revenue projections are very conservative
- Partial year operations, phased in reactivation, uncertainty about the ongoing impacts of COVID-19 on program participation
- Cost recovery in FY 2021-22 projected at 80%
- Program historically achieves more than 100% cost recovery when at full capacity

**Table 3. Gymnastics program revenues**

	Fiscal year 2017-18 actual	Fiscal year 2018-19 actual	Fiscal year 2019-20 actual	Fiscal year 2020-21 actual	Fiscal year 2021-22 proposed
Revenues (fees, etc.)	\$1,741,451	\$1,257,112	\$960,719	\$0	\$450,000
<b>Total</b>	<b>\$1,741,451</b>	<b>\$1,257,112</b>	<b>\$960,719</b>	<b>\$0</b>	<b>\$450,000*</b>

# RECOMMENDATIONS

- Direct staff to reactivate the gymnastics program starting in November 2021
- Authorize 5.75 full-time equivalent (FTE) employees to support gymnastics program operations, consistent with program staffing levels in fiscal year 2018-19
- Amend the fiscal year 2021-22 operating budget to include \$767,000 total budgeted expenditures and \$450,000 total projected revenues for gymnastics program operations.





## STAFF REPORT

### City Council

Meeting Date:

9/21/2021

Staff Report Number:

21-184-CC

Regular Business:

**Adopt the Transportation Management Association feasibility study final report**

### Recommendation

Staff recommends that the City Council adopt the Transportation Management Association (TMA) feasibility study final report (Attachment A.)

### Policy Issues

The development of a TMA supports the City's Transportation Demand Management (TDM) program guidelines and is listed as program CIRC-6.B in the 2016 General Plan circulation element to "assist local residents, employees, students, and other community members in identifying and taking advantage of travel options between employment centers and rail connections, downtown and nearby cities."

### Background

The development of a TMA is identified in the 2021 City Council work plan, and is a strategy in the adopted 2020 climate action plan (CAP No. 4.) The goal of a TMA is to coordinate logistics and TDM services amongst multiple member businesses. Instead of an individual business providing TDM services for their employees, a TMA allows multiple businesses to share TDM resources and creates cost-efficiencies that allow smaller businesses to access services that otherwise would not be affordable.

City staff and the consultant, Steer Group, started the TMA feasibility study in the summer of 2019. Since then, the COVID-19 pandemic and its impact on businesses as well as the launch of a new sub-regional transportation program, Manzanita Transit, led the team to pivot from evaluating creating a city-led TMA (whether at the sub-regional or citywide level) to pursuing a more cost-effective hybrid model that leverages existing services and fills in gaps to ensure that businesses of all sizes have access to commute program planning and implementation services. The project timeline was delayed in order to gather more details about the state of commuting in the Bay Area due to the ongoing COVID-19 pandemic and the operational start in November 2020 of Manzanita Transit's Ravenswood Transit Consortium in the Mid-Peninsula sub-region. On April 13, 2021, staff provided the City Council with a project update (Attachment B.) On April 14, 2021 staff presented an update and requested feedback from the Complete Streets Commission (Attachment C.)

Since April 2021, staff refined the feasibility study based on feedback from the City Council and Complete Streets Commission, along with ongoing regional initiatives around the Bay Area and feedback from Manzanita Transit and San Mateo County's Commute.org. Several strategies are discussed to help the City achieve these objectives, all of which involve collaborating with Manzanita Transit and Commute.org, as

described further below.

## **Analysis**

Since July 2020, many external factors have caused the City to reevaluate its original strategy in recommending the Citywide or region/sub-regional TMA options. Specifically, new information regarding the ongoing COVID-19 pandemic, the Metropolitan Transportation Commission (MTC) telework policy, and the operational start of Manzanita Transit programs have necessitated that the feasibility study plan for a new normal.

Therefore, the City creating a TMA would be duplicative of Manzanita Works' efforts, an inefficient use of resources, and potentially confusing to the public. The creation of Manzanita Transit's Ravenswood Transit Consortium in November 2020 gives it a head start on any City-related TMA actions. The timing and its collaboration across San Mateo and Santa Clara counties gives it great potential to be effective. Additionally, some potential larger employers in a future Citywide Menlo Park TMA may have already or are planning to join the Ravenswood Transit Consortium. The lack of membership from larger employers, along with their commensurate membership dues, may not allow for the viability for a cost-efficient Citywide TMA.

### The hybrid approach

New regional initiatives and the ongoing pandemic led Steer Group to recommend a hybrid approach to offer the benefits of both the Citywide and regional/sub-regional TMA options, while also being fiscally responsible. These options, shown in Table 1, were provided to the City Council in an informational item and presented to the Complete Streets Commission in April 2021. Three objectives and six strategies were proposed as alternatives for the City to pursue in lieu of the Citywide and regional/sub-regional TMA options.

Table 1: April 2021 draft TMA/TDM options	
Objective	Strategy
Objective 1: Endorse and support regional and sub-regional TDM efforts	Strategy 1.1: City joins Commute.org as a member Cost: City Council time as Commute.org board representative
	Strategy 1.2: City encourages employers and developers to participate in Manzanita Works, when possible Cost: Transportation Division, Planning Division staff time
Objective 2: Ensure TDM support is available for all businesses	Strategy 2A: City partners with Commute.org, who will provide contracted service to provide tailored education and engagement support to all Menlo Park businesses Cost: \$100,000 for contracted part-time employee (0.5 FTE)
	Strategy 2B: City sponsors small to medium-sized businesses to join Manzanita Works Cost: Estimated at \$100,000 for 50 small businesses
Objective 3: City can serve as an example of an employer with a robust and collaborative TDM program	Strategy 3.1: City joins Manzanita Works to as way to offer more commuter benefits Cost: Estimated at \$50,000-\$100,000 as medium-sized employer
	Strategy 3.2: City promotes Commute.org's full suite of free services to its employees Cost: TDM Coordinator staff time

After the City Council and Complete Streets Commission meetings, the feedback indicated that this draft plan needed to be further refined. The Complete Streets Commission approved a motion to pursue Strategies 1.1, 1.2, 3.2 and take action immediately, while pursuing Strategies 2A/2B, 3.1 more slowly as the City needed more information from the organizations and pandemic situation. Additional feedback at the City Council meeting affirmed doubt for Strategy 2A/2B, specifically why select just one entity rather than being able to draw from both organization's programs and strengths.

Since April 2021, City staff has worked with Steer Group to further refine recommendations to bring forth in the TMA feasibility study final report. City staff and Steer Group have worked more closely with representatives from Commute.org (San Mateo County's Transportation Demand Management agency) and Manzanita Transit. Through these conversations, the City has learned more about what both Commute.org and Manzanita Transit can offer. The end goal of both organizations are similar, with their synergistic relationship working to better commutes for employers and residents in San Mateo County. As an established entity with many programs, Commute.org has many services that Manzanita Transit can collaborate on and not need to duplicate. Conversely, Manzanita Transit's end goals are some programs and services that Commute.org may not offer. Ultimately, the City understands that working with both Commute.org and Manzanita Transit can offer programs and services that can fit its TDM needs.

While working with Commute.org and Manzanita Transit over the last few months has offered clarity for one aspect of the TMA feasibility study, there are still other unknowns as the COVID-19 pandemic continues to influence travel behaviors. The return of workers to offices and commutes, are still a moving target. There was optimism that many employees working remotely would begin returning to offices in September 2021, given that many seniors, adults, adolescent, and vulnerable populations had received vaccinations. Additionally, many major transit agencies in the Bay Area, such as Caltrain, BART, SamTrans

and Muni, have returned to near pre-pandemic service levels in August and September 2021 to accommodate the anticipated transit demand.

However, the rise of the highly transmissible Delta variant of the virus amongst vaccinated and non-vaccinated populations has created cause for concern, since its official declaration in June 2021. That concern has led Facebook, a major employer in Menlo Park, to push back its office return to January 2022 from September 2021. This move is similar to other large technology companies in the region, such as Apple and Google. As employers in Menlo Park, including the City itself, contemplate return to work and the integration of hybrid work-from-home schedules, commuting patterns and demands will continue to be unknown in the near future.

After working with Commute.org and Manzanita Transit, along with identifying potential obstacles to commuting, Steer Group revised the recommendations that were shared in April 2021. These short-term and longer-term strategies are described in Chapter 5 of the TMA feasibility study final report (Attachment A) with Table 2 listing the revised objectives and strategies.

<b>Objective</b>	<b>Strategy</b>	<b>Implementation timeline</b>
Objective 1: Endorse regional TDM efforts	Action 1 (formerly Strategy 1.1): City joins Commute.org as a member Cost: City Council time as Commute.org board representative	Year 1: Late 2021/Early 2022
	Action 2 (formerly Strategy 1.2): City encourages employers and developers to participate in Manzanita Works, when possible Cost: Transportation Division, Planning Division staff time	Year 1: Late 2021/Early 2022
Objective 2: City can serve as an example of an employer with a robust and collaborative TDM program	Action 3 (formerly Strategy 3.2): City promotes Commute.org’s full suite of free services to its employees Cost: TDM Coordinator staff time	Year 1: Late 2021/Early 2022
	Action 4 (formerly Strategy 3.1): City joins Manzanita Works to as way to offer more commuter benefits Cost: Estimated at \$40,000	Year 2 to 3: FY 2022-23, 2023-24
Objective 3: Ensure TDM support is available to all businesses	Action 5 (formerly Strategy 3.2): Invest in sub-regional resources (Commute.org, Manzanita Transit) to provide targeted Citywide support Cost: Estimated at \$30,000-\$120,000	Year 2 to 3: FY 2022-23, 2023-24

**Staff recommendations**

Staff recommends that the City pursue a phased implementation of the objectives and actions in Table 2. This will allow the City to strategically phase in TDM support and services in response to how the region recovers from the COVID-19 pandemic. The phased approach will be implemented over the next few years in order to adequately budget and understand the new commuting patterns.

Actions 1, 2, and 3 are more straightforward for implementation in fiscal year 2021-22, and this phased approach is in line with the Complete Streets Commission recommendation in April 2021. In order to pursue Action 4, the City will need to identify its commuter benefits needs in fiscal year 2021-22. Additionally, budget will need to be identified for commuter benefits, such as the Caltrain Go Pass, and membership dues to join Manzanita Transit. Staff will return to City Council for action to join Commute.org and to appropriate funds to expand programs as part of the midyear budget review (early 2022) or annual budget adoption process (April through June 2022.)



Lastly, to pursue Action 5 the City will need to survey businesses to understand new commuting patterns post-COVID, along with budgeting for both the survey and implementation of Action 5 programs with Commute.org and Manzanita Transit. While surveying could begin in year one of the schedule, it is anticipated to be more effective in year two based given the unknowns of the COVID-19 pandemic and full return to work. It is anticipated that Action 5 will require planning, monitoring and research over the next few years.

Additional long-term strategies to aid with longer-term deployment of TDM services to all businesses in Menlo Park are listed in Chapter 5 of the TMA feasibility study final report, including:

- Research post-pandemic commute patterns with surveys, Streetlight data (anonymized location data from smartphones and navigation devices), and programs that incentivize tracking/logging trips.
- Identify new funding sources to support these new initiatives.
- Revise TDM program guidelines for new developments to codify more current TDM requirements for reducing trips. This could include an update to the Municipal Code for certain zoning districts and/or updating the 2015 TDM program guidelines.
- Update the TDM program guidelines, which are based on C/CAG's, based on City needs and/or C/CAG's updates, such as their current revision process in 2021.

The end goal is to have the City and employers achieve tangible shifts from single-occupant vehicle commutes to transit, bicycling, walking and carpool/vanpool. This approach to innovating the commute through the hybrid strategies will reduce congestion and greenhouse gas emissions, which supports other City-led initiatives such as the general plan, transportation master plan and CAP.

### **Impact on City Resources**

This feasibility study was funded by a \$100,000 contribution required as part of the Facebook campus expansion project development agreement. Additional staff resources and budget may be needed depending on which TMA implementation strategies are identified to move forward.

### **Environmental Review**

This action is not a project within the meaning of the California Environmental Quality Act (CEQA) Guidelines §§ 15378 and 15061(b)(3) as it will not result in any direct or indirect physical change in the environment. Each strategy or action proposed would be subject to environmental review at the time of approval or implementation.

### **Public Notice**

Public notification was achieved by posting the agenda, with the agenda items being listed, at least 72 hours prior to the meeting.

### **Attachments**

- A. TMA feasibility study final report
- B. Hyperlink – TMA feasibility study, April 13, 2021, City Council staff report:  
[menlopark.org/DocumentCenter/View/27882/L3-20210413-CC-TMA-update](https://menlopark.org/DocumentCenter/View/27882/L3-20210413-CC-TMA-update)
- C. Hyperlink – TMA feasibility study, April 14, 2021, Complete Streets Commission staff report:  
[menlopark.org/DocumentCenter/View/27881/SR-TMA-Implementation-Plan-Update-to-CSC](https://menlopark.org/DocumentCenter/View/27881/SR-TMA-Implementation-Plan-Update-to-CSC)

Staff Report #: 21-184-CC

Report prepared by:  
Nicholas Yee, Transportation Demand Management Coordinator

Report reviewed by:  
Kristiann Choy, Senior Transportation Engineer  
Hugh Louch, Assistant Public Works Director - Transportation

Report  
September 2021

# City of Menlo Park Feasibility Study Final Report

---





# City of Menlo Park Feasibility Study Final Report

---

Prepared by:

Steer  
800 Wilshire Blvd, Suite 1320,  
Los Angeles, CA 90017  
USA

+1 (213) 425 0990  
[www.steergroup.com](http://www.steergroup.com)

Prepared for:

City of Menlo Park  
701 Laurel St.,  
Menlo Park, CA 94025

23642101

Steer has prepared this material for City of Menlo Park. This material may only be used within the context and scope for which Steer has prepared it and may not be relied upon in part or whole by any third party or be used for any other purpose. Any person choosing to use any part of this material without the express and written permission of Steer shall be deemed to confirm their agreement to indemnify Steer for all loss or damage resulting therefrom. Steer has prepared this material using professional practices and procedures using information available to it at the time and as such any new information could alter the validity of the results and conclusions made.

## Contents

<b>1</b>	<b>Executive Summary .....</b>	<b>1</b>
<b>2</b>	<b>Introduction .....</b>	<b>3</b>
2.1	Study Goals.....	3
2.2	Existing Conditions Analysis .....	3
2.3	New Direction .....	4
2.4	Alignment with Regional and City Goals and Plans.....	4
<b>3</b>	<b>Existing Conditions .....</b>	<b>6</b>
3.1	Travel Patterns .....	6
3.2	Current TDM Efforts.....	11
3.3	Behavioral Insights .....	14
3.4	Conclusions .....	15
<b>4</b>	<b>Recommendations.....</b>	<b>16</b>
4.1	Recommendation Development Process.....	16
4.2	Recommended Actions .....	17
4.3	Summary of Recommended Actions.....	23
<b>5</b>	<b>Next Steps .....</b>	<b>24</b>
5.1	Implement Short-Term Strategies .....	24
5.2	Understand Post-COVID Needs and Priorities .....	24
5.3	Identify Funding Sources.....	26
5.4	Revise TDM Program Guidelines.....	27
5.5	Consider Implementation Plan for Long-Term Actions.....	27
5.6	Expected Timeline .....	28
<b>6</b>	<b>Conclusion.....</b>	<b>29</b>

# 1 Executive Summary

The City of Menlo Park has a goal to reduce vehicle trips and increase access to transportation options in accordance with its Climate Action Plan, Complete Streets Policy, and Transportation Plan. A Transportation Management Association (TMA), an organization dedicated to providing programs and services to help employers, developers, and other stakeholders address local transportation and air quality concerns by encouraging more efficient modes of travel, was identified as a viable option.

The City commissioned a TMA Feasibility Study in spring of 2019 to examine the potential for TMA, who it could serve, and what the organization could look like. The study kicked off with an existing conditions analysis to understand current commute patterns as well as inventory TDM resources already available within the city. An options analysis followed in which the different TMA structures were compared against the City's goals, needs, and priorities. The last phase of the study as originally scoped involved the development of an implementation plan for the formation of a TMA. City Council, the Complete Streets Commission, and stakeholders were consulted throughout the process to provide input and direction.

The emergence of the COVID-19 pandemic at the beginning of 2020 coincided with the initiation of the last phase and caused a delay in the study. When efforts resumed in Fall 2020, the Project Team quickly realized that much has changed. As a result of the Shelter in Place Order, many businesses had to reduce capacity or furlough staff, large portions of the employee population were working from home, and a consortium focused on providing sub-regional TDM services, Manzanita Works' Ravenswood Transit Consortium, officially launched. Given the changes, the Project Team determined the formation of a TMA would not be necessary. Instead, it would be more cost-effective to partner with existing TDM organizations to expand TDM services within the city.

This document, therefore, lays out the findings for the entire study, including the justification for not forming a Menlo Park TMA and the revised recommendations for the City going forward. Based on feedback from the Complete Streets Commission and partner organizations and in response to the continually changing landscape, the report recommends several potential actions partnerships and additional studies to explore but stops short of outlining an implementation plan and budget. This would allow the City to continue to assess the impact of the pandemic on commute patterns and transportation needs within the city, keep apprised of how the new sub-regional organization develops, and explore how it could best collaborate with partner organizations to expand TDM support throughout the city.

This report outlines the following objections as well as recommended actions for the City to consider:

**Table 1 Summary of TDM Objectives and Recommended Actions**

Objective	Action
<b>Endorse regional TDM efforts</b>	Action 1: Join Commute.org JPA
	Action 2: Encourage employers to participate in Manzanita Transit
<b>Position the City as an example of a robust employer program</b>	Action 3: Promote Commute.org’s full suite of services to its employees
	Action 4: Join Manzanita Transit to supplement existing employee commuter benefits
<b>Ensure TDM support is available to all businesses</b>	Action 5: Invest in existing sub-regional resources to provide targeted Citywide support



## 2 Introduction

### 2.1 Study Goals

In the spring of 2019, the City of Menlo Park published a Request for Proposals seeking guidance on the development of a Transportation Management Association (TMA). While TDM exists in many worksites across Menlo Park already, the City was seeking support in the form of an organization that would help to leverage partnerships across the city and sub-region and support the provision of TDM service to a broader group of employers. The study was meant to explore four unique options for TMA structure, and compare their expected success in reducing citywide vehicle miles traveled, changing travel behavior, and supporting stakeholder engagement and partnerships.

### 2.2 Existing Conditions Analysis

The study started with an information gathering phase in which the Project Team analyzed anonymized mobile phone data to map travel patterns throughout the city, interviewed employers and business groups to understand their transportation-related challenges and needs, and distributed a commute survey to ask employees about their current commute habits and what would help them try an alternative mode of transportation.

Following the Existing Conditions analysis, the Project Team was asked to consider potential options for a TMA in the city. Based on the information gleaned from the prior analysis and input from City Council, the Project Team proposed five potential models:

- Status Quo – no TMA is established and TDM requirements continue to flow through Development Agreements, conditions of approval, and/or mitigation measures identified through the environmental review process to reduce potential environmental effects
- Regional/Sub-Regional TMA – the City would work with neighboring municipalities to join or create a sub-regional organization.
- Large Employer TMA – the Menlo Park TMA would be set up to serve large employers and multi-tenant office buildings with 250 or more employees
- Small Employer TMA – the TMA would serve small employers and organizations, prioritizing those in the Downtown zone
- Citywide TMA – the TMA would serve both small and large employers across the city.

Each model was evaluated based on three categories:

- Estimated impact: employees and stakeholders engaged, mode share, and VMT reduced;
- Estimated cost: start up and ongoing cost as well as membership potential; and
- Alignment with City goals and City role.

The Project Team presented the findings to City Council and were given direction to further explore the Regional/Sub-Regional and Citywide models.

## 2.3 New Direction

In light of recent developments, such as the COVID-19 pandemic and the launch of Manzanita Transit (Manzanita Works' Program), it was determined that creating a separate TMA, whether at the sub-regional or citywide level, would no longer be the most cost-effective and efficient strategy for the City. Instead, the Project Team determined that the City will be better served by adopting a hybrid model leveraging existing services and filling in gaps to ensure that all businesses have access to commute program planning and implementation services.

In addition, given the current landscape (including the continued growth and evolution of the Manzanita Transit program, uncertainty surrounding available budgets and what types of services would be most impactful as businesses return to the worksite) and in coordination with partner organizations, the intent of this report shifted from recommending clearly-defined actions with distinct budgets to the identification of opportunities for the City and partners to explore further. This change in direction still provides the City with next step actions while allowing for flexibility in how to best build off of and expand current TDM efforts within the city during these uncertain times.

## 2.4 Alignment with Regional and City Goals and Plans

---

*“Menlo Park provides thoroughly-connected, safe and convenient transportation, adequate emergency vehicle access, and multiple options for people traveling by foot, bicycle, shuttle, bus, car, and train, including daily service along the Dumbarton Rail Corridor.”*

*-City of Menlo Park General Plan*

---

The objectives laid out in this report support the City's goals to reduce vehicle trips and increase access to transportation options. The strategies identified here align with the City's plans and policies, including:

- **General Plan, Circulation Element** – The Circulation Element of the General Plan describes the key issues and opportunities in the community. Program CIRC-6 B recommends the formation of a TMA to provide assistance to local residents, employees, students, and other community members in identifying and taking advantage of travel options between employment centers and rail connections, downtown, and nearby cities. In addition, it requires new, large commercial and residential developments to participate in the TMA, once formed. While the formation of a TMA is no longer recommended, the strategies recommended in this report serve the same purpose of providing assistance, education, and support to help members of the community make informed decisions about how they travel.
- **Climate Action Plan** – The City's 2030 Climate Action Plan (CAP) updated in 2020 calls for a 25% reduction in vehicle miles traveled (VMT) (Plan Item #4). The actions identified in this

report will not only assist in reducing VMT by encouraging the use of alternative modes of transportation, including transit, carpool, vanpool, biking and walking, but would also help reduce congestion, lower GHG emissions, reduce the carbon footprint in Menlo Park.

- **Complete Streets Policy** – The Complete Streets Policy acknowledges the benefits and value for the public health and welfare of reducing vehicle miles traveled and increase transportation by walking, bicycling, and public transportation through the provision of supportive infrastructure.
- **Transportation Master Plan** – The TMP seeks to identify and prioritize key projects to implemented as a path forward to achieving the City’s General Plan goals of: Safety, Sustainability, Mobility Choice, and Congestion Management. By promoting and encourage the use of non-drive along modes, this Plan are in line with these goals.

By leveraging existing TDM programs, the City will be able to provide supportive services and amenities in the most cost-effective manner, allowing for more resources and funds to be redirected toward efforts to raise awareness and encourage adoption of non-drive alone modes of travel.

# 3 Existing Conditions

In 2019, the Project Team conducted an Existing Conditions Analysis to understand the travel patterns, transportation challenges, and available TDM resources within the city. Of note, this information was recorded prior to the COVID-19 Pandemic.

## 3.1 Travel Patterns

StreetLight Data, which anonymizes location records from smart phones and navigation devices, was used to understand vehicular travel patterns within and through the city. Data was pulled for the four Focus Area Zones:

- **Northern Menlo Park** – also known as the Bayfront area, this zone includes the area north of the 101 Freeway and north of the Dumbarton corridor.
- **Central Menlo Park** – the area between the 101 and Freeways which includes City Hall, the Menlo Park Library, and the Veterans Affairs (VA) campus.
- **Downtown Menlo Park** – which encompasses either side of Santa Cruz Ave. between University Dr. and Alma St.
- **Southern Menlo Park** – this zone covers the area abutting Sand Hill Rd. and the 280 Freeway as well as the SLAC area.

Figure 1 Map of Menlo Park Zones

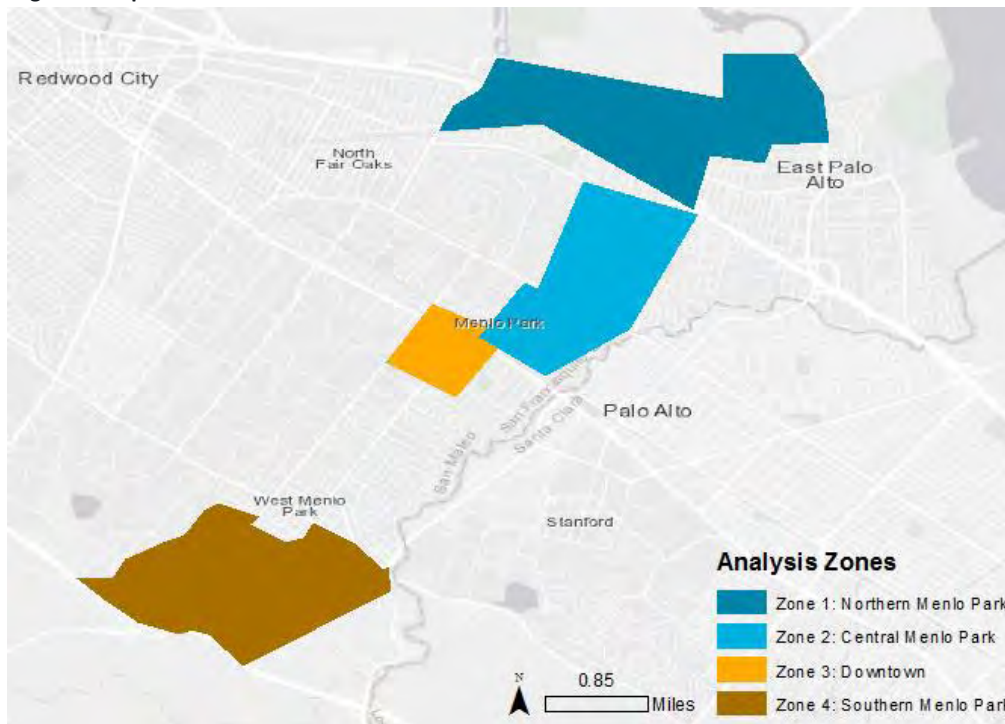

### 3.1.1 Northern Menlo Park

Home to some of the city’s largest employers, including Facebook and life sciences employers within the Menlo Park Labs life sciences park,, Northern Menlo Park attracts and contributes to the most trips of all four zones analyzed. Trip origin and destination counts tend to follow a traditional commute-style pattern, with more trips coming into the zone during the morning peak (between 6am and 10am) and leaving the zone during the evening peak (between 3pm and 7pm). The greatest concentration of trips arriving into the zone originate from the adjacent block group, indicating that many employees live and work locally and have relatively short commute trips. The next highest concentration of employees arrive from across the Dumbarton Bridge.

Figure 2 Northern Menlo Park AM Peak Trip Origin Zones

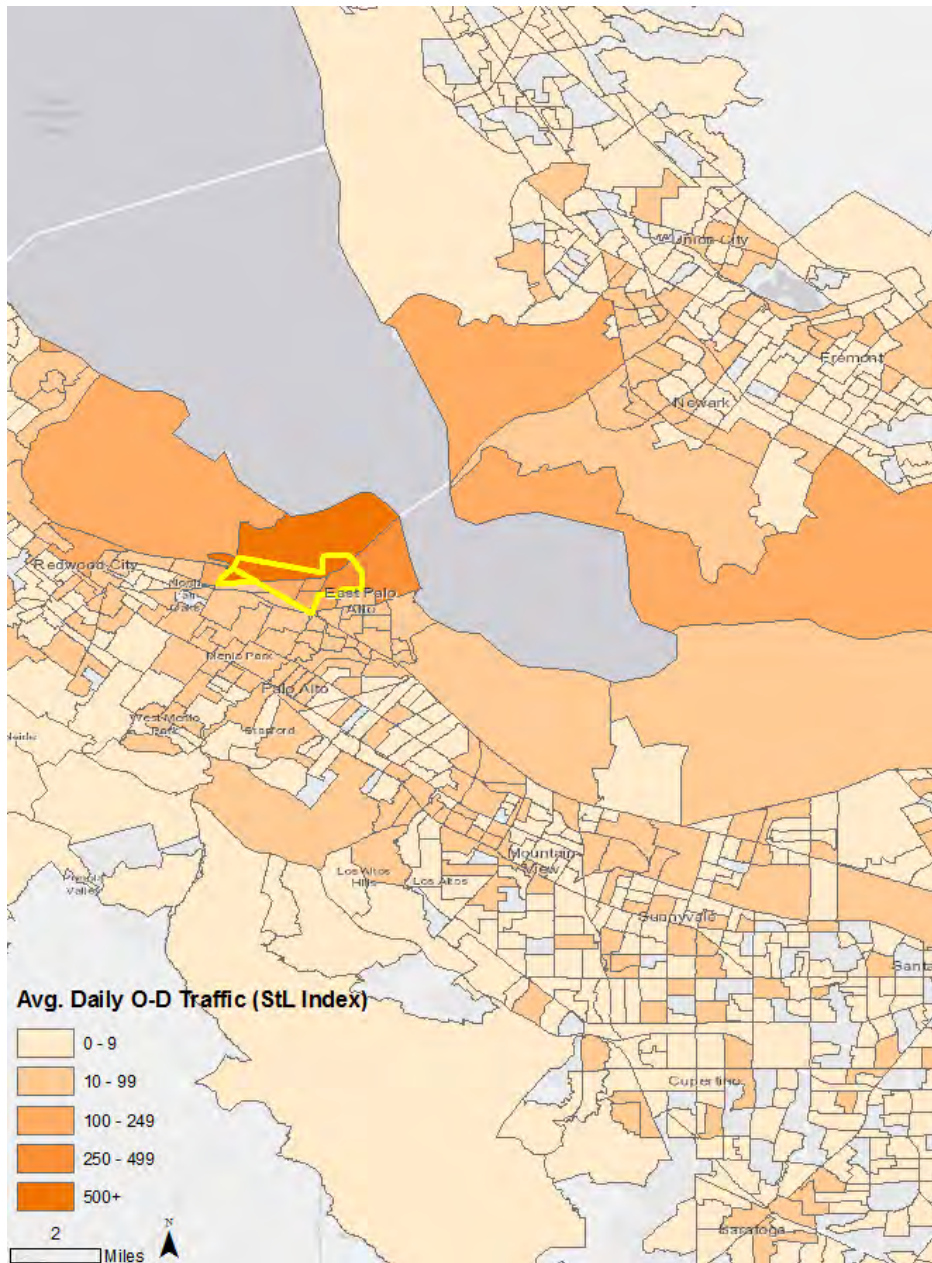

### 3.1.2 Central Menlo Park

Travel volumes are higher both into and out of this zone during the evening peak, which indicates that the zone likely attracts non-work-related trips after traditional morning peak hours. During the morning peak, the majority of trips come from nearby, with concentrations originating in neighboring Atherton and Redwood City.

Figure 3 Central Menlo Park AM Peak Trip Origin Zones

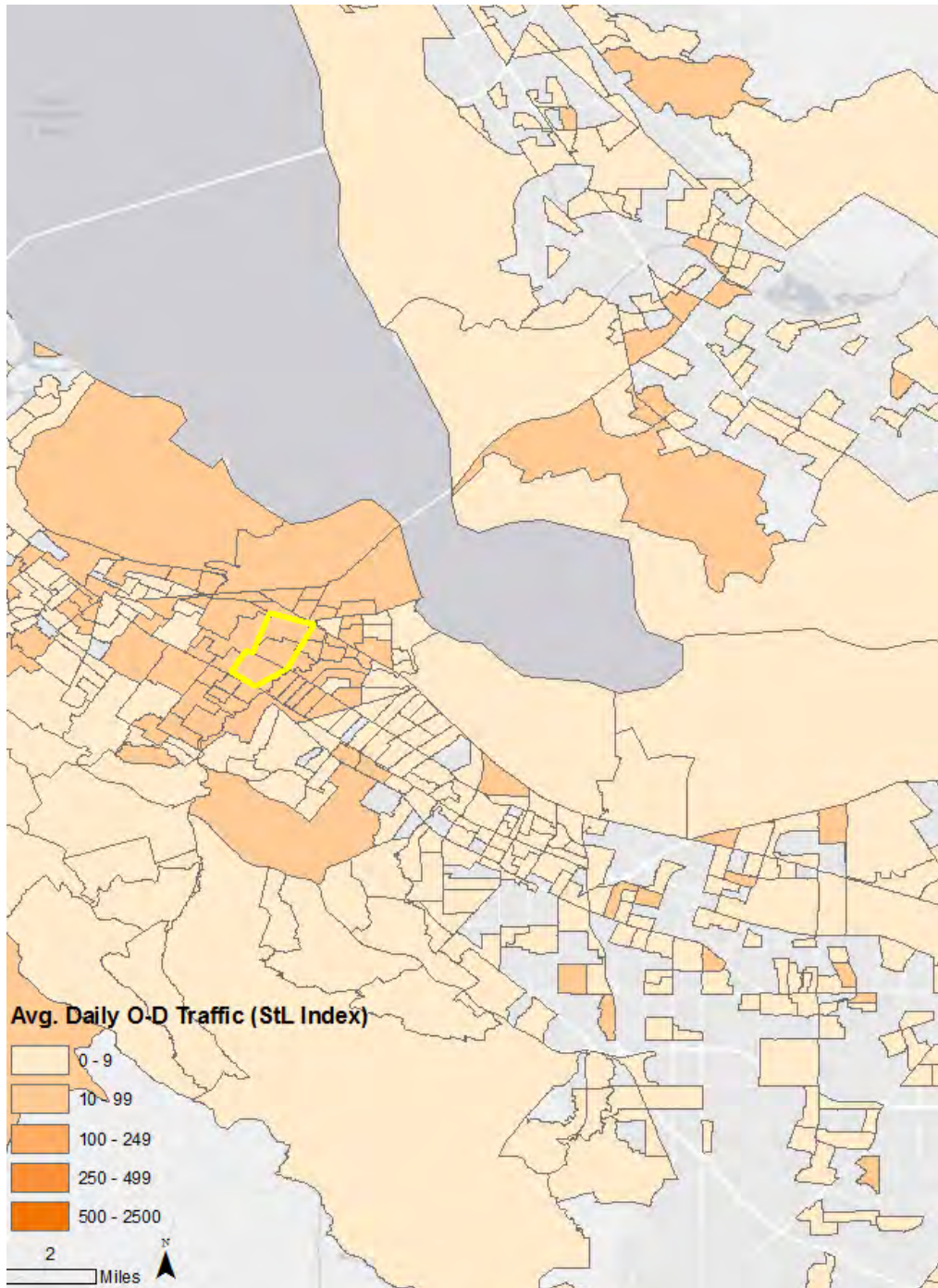

### 3.1.3 Downtown Menlo Park

The Downtown Zone both attracts and originates more trips in the evening peak than it does in the morning peak, possibly due to the many retail and restaurant establishments in the area which tend to have later operating hours. The majority of trips originate within 2-3 miles from Downtown Menlo Park.

Figure 4 Downtown Menlo Park AM Peak Trip Origin Zones

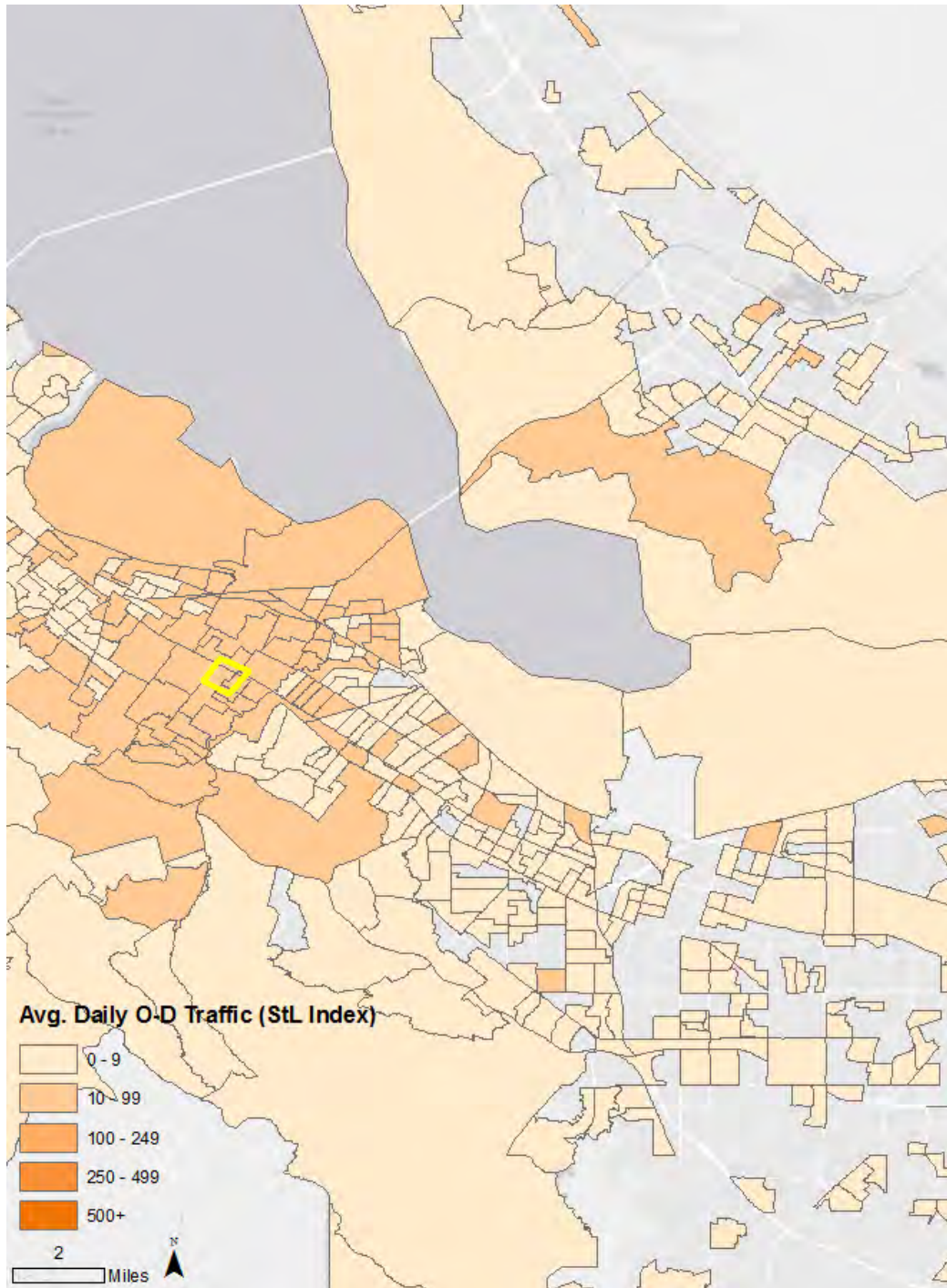

### 3.1.4 Southern Menlo Park

Similar to the Northern Menlo Park Zone, the Southern Menlo Park Zone’s travel pattern is in line with what is expected of traditional commute travel, with a higher concentration of trips entering during the morning peak and leaving during the evening peak. However, the number of trips both in and out of the zone is less than half of those coming in and out of the Northern Menlo Park area. Of note, this zone does not include the neighboring Stanford University campus, which likely contributes to additional congestion along the same roadways. While trips originate from across Menlo Park, this area received the fewest trips from the East Bay.

Figure 5 Southern Menlo Park AM Peak Trip Origin Zones

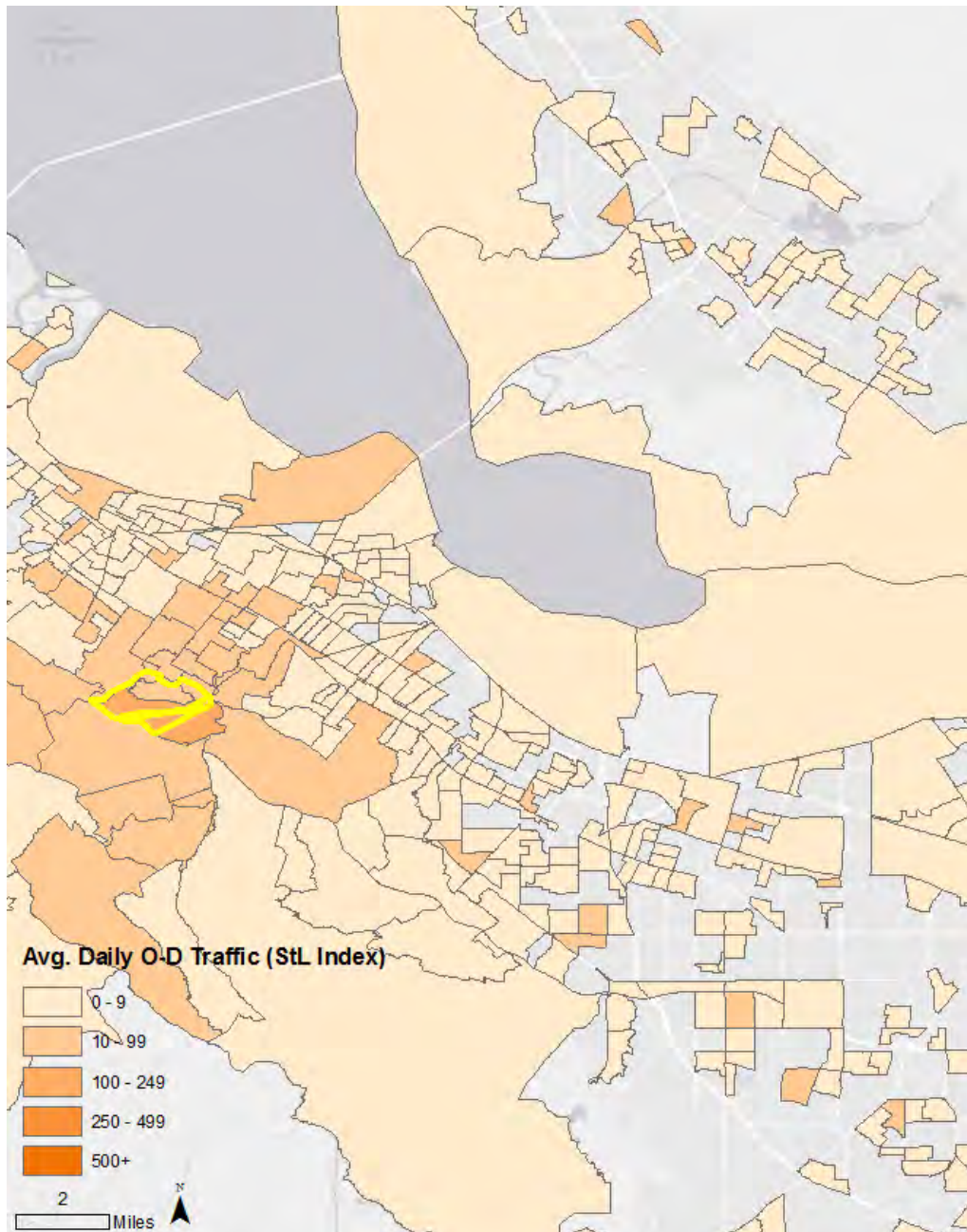



## 3.2 Current TDM Efforts

### 3.2.1 Citywide Efforts

The City requires that developers of new projects which trigger the TDM Program Guidelines (i.e., create between 0.5 to 1.0 second of delay to any of the impacted study intersections or projects within the M-2 area including a proposed change of land use) work with the Transportation Division to put together TDM plans guided by the City/County Association of Government's (C/CAG) TDM Program Guidelines, which include both site and programmatic elements. In addition, TDM measures may be required based on the project's environmental impact analysis or as part of development agreement negotiations. These plans are then meant to be reviewed periodically by City staff in order to ensure that current owners and managers are implementing the agreed upon programs, but the City does not have the resources nor a formal mechanism in place for regular review or monitoring.

The City's policies are more comprehensive for projects located within the M-2 area along the Bayfront, where the Zoning Ordinance requires developers to submit TDM Plans and reduce trips by 20% in order to simplify their permitting and approvals on projects. On a case by case basis, City staff work with developers to agree upon TDM services and programs that will be offered. These may include the requirement of first/last mile shuttles to and from transit stations or requirements to provide the City with traffic count information daily and demonstrate that trip reduction goals are met.

In addition, projects subject to the El Camino Real and Downtown Specific Plan are required to include a range of measures to mitigate the environmental impact of the Specific Plan. To mitigate anticipated traffic as a result of future development in the Plan area, new developments are required to have in place a City-approved TDM program prior to project occupancy (Impact TR-2).

TDM requirements are applied by the City to projects based on applicability under the following:

- i. Conditions of approval from Zoning Ordinance
- ii. Conditions of approval from the Specific Plan
- iii. Compliance with the City's TDM guidelines
- iv. Applied mitigation measures from environmental analyses where the TDM is used to reduce a potential impact; and
- v. Negotiated requirements from development agreements.

### 3.2.2 Site Level Efforts

The City's policies are more comprehensive for projects located within the Bayfront Area meeting a certain threshold (i.e., 10,000 or more square foot of new construction or tenant improvements), where developers are required to submit TDM Plans and reduce trips by 20%. On a case by case basis, City staff work with developers to agree upon TDM services and programs that will be offered. These may include the requirement of first/last mile shuttles to and from transit stations, or, in the case of the City's largest employer (Facebook), requirements of negotiated development agreements for the East and West Campus require Facebook to provide the City with traffic count information daily and demonstrate that trip reduction goals are met. These requirements were adopted as part of the land use entitlements for the East and West Campus and predate the City's Zoning Ordinance TDM requirements.

Due to the parking limitations in the Downtown Area, larger businesses located in that zone tend to provide Go Passes (Caltrain's corporate pass) to their employees. However, because Downtown businesses are primarily made up to smaller retail employers, they tend to lack the resources and support to implement a more robust TDM Program at their worksites.

### 3.2.3 Sub-Regional Efforts

In addition to site-based and municipal programs, TMAs and similar organizations provide services across the Bay Area and in Menlo Park.

#### *TMAs*

The closest TMAs in proximity to Menlo Park are the Palo Alto TMA, which focuses primarily on providing transit subsidies to small downtown businesses, and the Stanford Research Park's SRPGO program which provides shuttle service and other TDM programs to their tenants. Also nearby is the Mountain View TMA, and neighboring Redwood City is exploring the idea of developing a TMA as well.

#### *Commute.org*

Commute.org is a Joint Powers Authority (JPA) governed by a board of 18 elected officials, one from each of the 17 cities and the County of San Mateo. As San Mateo County's Transportation Demand Management Agency, its mission is to reduce traffic congestion and greenhouse gas emissions while enhancing the quality of life in San Mateo County by promoting the use of sustainable transportation and commute alternatives. The agency does this by providing information and commute planning assistance to residents, employees, employers, and city transportation demand management partnerships.

All San Mateo County employers, residents, and commuters have access to Commute.org's services, including:

- Assistance with Bay Area Commuter Benefits Program Compliance;
- First/last mile shuttle services;
- Guaranteed Ride Home;
- Vanpool and Carpool ridematching services and subsidies;
- Free Transit Ticket Program;
- Reward and Incentives Program;
- Employee commute program consultation;
- Employee transportation coordinator (ETC) support;
- Employee surveying for TDM compliance and mode split analysis;
- On-site events (e.g., bicycle safety education); and
- TDM Agency of Record for San Mateo County for worksites required to provide TDM benefits.

Funded by C/CAG, the San Mateo County Transportation Authority (TA), the Bay Area Air Quality Management District (BAAQMD) and the Metropolitan Transportation Commission (MTC), the organization is a free service available to all employers in San Mateo County.

Commute.org is also assisting C/CAG with their updated TDM Guidelines and Compliance program. The program will require new developments that exceed certain vehicle trip counts to comply with countywide TDM measures. Commute.org will work with local officials, C/CAG,

developers, and tenants to collect and report on compliance with the program. Commute.org envisions that the database will be used by the agency to assist municipalities with compliance tracking for existing developments when appropriate.

While the City has not joined the Commute.org JPA, the City does leverage some of Commute.org's services for their own employees and Staff, such as promoting the Guaranteed Ride Home and incentives program.

#### *Manzanita Works' Ravenswood Transit Consortium*

A non-profit organization founded in 2014, Manzanita Works brings together public and private employers in the region with the goal of improving the welfare of workers and their families through increased access to transit, housing, food, health services, and childcare. The organization's Manzanita Transit program incorporates guiding principles gleaned from recommendations made by local elected officials and prominent regional tech employers shared during the 2019 Manzanita Talks which sought to explore the coordination of TDM services throughout the Bay Area. The organization legally ratified the "Ravenswood Transit Consortium" in May 2020, a sub-regional consortium to better connect commuters between home and their place of work, with Google and the Ravenswood Family Health Network as founding members. Since then, the program has:

- Convened stakeholders in discussions about regional challenges;
- Launched a free long-haul shuttle service for essential workers;
- Collaborated with Caltrain on their GoPass distribution pilot;
- Initiated a bike loan program feasibility study;
- Offered bike repair and maintenance events in collaboration with Good Karma Bikes; and
- Is in the process of initiating a bikeshare feasibility study in partnership with Bay Area cities.

While Manzanita Transit is the overarching program bringing together stakeholders and partners throughout the region, consortiums are organized based on subregional geography to ensure more focused discussions on existing local problems the members seek to address and crafting solutions that take into consideration local leadership from voluntary civic society from within the local community. Because commutes may span multiple cities and counties, these sub-regions may cross county lines and jurisdictions. Menlo Park falls under the Ravenswood Subregion, which encompasses the Mid-Peninsula from Sunnyvale in Santa Clara County to Redwood City in San Mateo County.

The consortium model offers a forum for members and stakeholders to discuss current challenges and identify solutions and provides the connections and administrative support to bring them to fruition. For example, as a result of COVID-19 and state-mandated Shelter in Place Orders, there was both a reduced demand for employer-provided shuttles and an increased need to assist essential workers to their worksites. The organization led the effort in developing the agreement and process by which employers were able to donate their unused shuttle vehicles to be used by essential workers free-of-charge. They led the creation of six routes connecting the eight cities of Livermore, Richmond, Oakland, Daly City, Hayward, San Leandro, Fremont and South San Jose to East Palo Alto with connecting service to Palo Alto, Mountain View and Sunnyvale within the Ravenswood subregion.

**Table 2 Essential Workers Commute Shuttle Pilot Routes**

	Route
Route 1A	Livermore to East Palo Alto
Route 4A	Richmond to East Palo Alto
Route 7A	Daly City to East Palo Alto
Route 9A	Hayward to East Palo Alto
Route 10A	Fremont to East Palo Alto
Route 14A	South San Jose to East Alto

As a member-based organization, employers join their local consortium and pay an annual fee based on the type of employer category under which they fall. Employers in Menlo Park who join the Ravenswood Transit Consortium as members have access to:

- A “seat at the table” with their local Consortium to initiate and shape services;
- Caltrain GoPasses for eligible employees as available through Caltrain’s pilot;
- Access to Essential Express long-haul shuttle services for essential and returning workers as available;
- Bike Commuter Support; and
- Employee commute program consultation including promoting existing community resources including Commute.org’s programs and services, SamTrans, Caltrain and other public transportation options.

As a consortium, the Ravenswood Transit Consortium plans to implement additional programs in the near future based on member requests, priorities and participation. The consortium currently includes Menlo Park employers such as JobTrain, the Ravenswood City School District, and the US Geological Survey has completed its approval process to join. Facebook has sponsored the overall Manzanita Transit program of subregional consortium creation, facilitation and management.

### 3.3 Behavioral Insights

#### 3.3.1 Employer Insights

In addition to the quantitative analysis via StreetLight data, outreach to local employers and business groups was conducted to provide the full picture of what types of resources and services are currently available and being utilized within the city. The Project Team conducted eight interviews with Menlo Park employers, property owners, and business organizations. Many employers had similar responses, including:

- While there is plenty of TDM support and programming available for large employers, smaller employers tend to lack the capacity and resources to implement similar measures;
- There tends to be poor connections between transit providers and bike and pedestrian infrastructure which present first/last mile challenges;
- There is a potential to open use of private employer shuttles to wider populations;
- Some employers need marketing and education support to make their employees aware of their options; and
- Many employers expressed interest in more subsidies and incentives to encourage non-SOV commutes.

To reach small businesses, the Project Team also visited 39 businesses in Downtown Menlo Park and asked them about their employee's commuting habits and challenges. The businesses ranged in size from 2-65 employees with just under half of the businesses employing 10 or fewer employees. Key takeaways include:

- Almost 65% of interviewed businesses indicated that their employee's shifts coincide with regular business hours (8am-6pm);
- Driving alone was by far the most popular commute mode, followed by Caltrain, bus, walk, carpool, and bike;
- The biggest challenge employees face as part of their commute were traffic and parking; and
- Parking is a particular issue for retail workers for whom monthly parking passes are too costly and inflexible. Instead, many park on the street or move their cars periodically throughout the day within the timed lots.

### 3.3.2 Employee insights

The Project Team distributed an online survey to Menlo Park employees, with the goal of understanding more about travel behavior from small and medium-size businesses. Menlo Park's largest employers (primarily Facebook and tenants within Menlo Park Labs) typically conduct their own surveys annually and, rather than have their employees take a new survey, they provided insights from those processes in their interviews, as referenced in section 3.1.1. The survey received 98 responses in total, primarily from small to medium-sized employers in the Downtown and Central Menlo Park areas. Results are as follows:

- Most survey respondents traveled during the peak period (7-10am and 4-8pm);
- While drive alone was the main commute mode reported, 24% of respondents indicated biking as their primary commute mode;
- Of those who typically drive alone, 75% would be willing to try another mode of travel, with train, bike, and carpool as the top choices; and
- When asked about their main motivators for behavior change, commuters were most interested in saving time.

## 3.4 Conclusions

The TDM efforts and needs within the city may be summarized as follows:

- While employers are supportive of TDM efforts within the city, they are wary of overlapping programming and services and sensitive to costs;
- TDM programming is already strong in the Northern Menlo Park Zone. To ensure all businesses have access to TDM resources, focus should be on facilitating and connecting other small and medium-sized employers to TDM services.
- Strong TDM resources already exist within the city from Commute.org and Manzanita Works. Rather than duplicating efforts, the City should leverage these existing resources by helping them better connect with Menlo Park employers.

## 4 Recommendations

### 4.1 Recommendation Development Process

The Project Team consulted with and received valuable feedback from the Complete Streets Commission and partner organizations, Commute.org and Manzanita Works. Below is a summary of the feedback received.

#### 4.1.1 Complete Streets Commission

The Project Team presented the initial report to the Complete Streets Commission on April 14, 2021. The Commissioners were in favor of the City advancing regional/sub-regional efforts by joining Commute.org's Board of Directors, promoting both Commute.org to its staff, and directing developers and businesses who may need additional TDM support to Manzanita Works. The Commissioners were interested but wanted more information before taking action to join the Manzanita Transit Consortium and deciding on how to best provide citywide TDM services.

#### 4.1.2 Commute.org and Manzanita Works

The Project Team met with Commute.org and Manzanita Works several times throughout the project development process for input, updates on new services, and to brainstorm how both organizations could help expand TDM services to all Menlo Park businesses. Both organizations are supportive of the City's goals to provide citywide TDM services and would be able to assist in these efforts. However, rather than delineating the tasks between the two organizations, they agreed that a partnership in which both organizations worked together would be more cost-effective and collaborative.

Based on the above feedback and the current evolving landscape, it was determined that more time and information would be needed to ensure the City will be able to respond to changes in commute patterns and employee needs in a post-COVID environment and the growth of regional and subregional TDM programming. As such, the Project Team shifted gears from developing an implementation plan with distinct actions and budgets to outlining next steps and potential opportunities for the City to continue exploring ways to provide citywide TDM services in a manner that is cost-effective while still in line with current needs and priorities.

## 4.2 Recommended Actions

Informed by the existing conditions exercise, discussions with stakeholders, and direction from City Council, three objectives were identified based on the identified needs and opportunities for TDM implementation throughout the city.

2. Endorse regional TDM efforts
3. Position the City as an example of a robust employer program
4. Ensure TDM support is available to all businesses

The sections below provide additional context for each objective and outline recommended actions to support them.

### 4.2.1 Endorse Regional and Sub-Regional TDM Efforts

Through analysis of Streetlight data, as discussed in Section 3.1, the Project Team found that many employees commute into the city from neighboring cities as well as across the Dumbarton Bridge. Because of the regional nature of commutes, as well as the need for inter-city travel options, coordination with neighboring cities, transit agencies, and regional bodies was identified as a key objective for the City.

The City Council has also expressed interest in facilitating coordination between the City of Menlo Park and regional/sub-regional partners toward advancing TDM implementation, as evidenced by its participation and support for Manzanita Talks in 2018 and 2019. As described above, the City of Menlo Park and its employers have access to two organizations that provide TDM services across San Mateo County and beyond, Commute.org and Manzanita Works. It is recommended that the City partner with these existing regional/sub-regional organizations to provide TDM support and services to its businesses.

#### *Action 1: Join Commute.org JPA*

As an alliance of 17 cities and the County of San Mateo, cities are invited to join the organization's board and help guide its programming free of charge. Commute.org is governed by a Board of Directors made up of elected officials from each of the 18 member agencies. Menlo Park is one of only 3 jurisdictions in the County not currently a member of Commute.org.

While City Council had previously supported a recommendation to authorize the Mayor to sign a letter to join Commute.org in 2018, the passing of *Assembly Bill 1912 Public Employees' Retirement: Joint Powers Agreements: Liability* (AB1912) presented temporary challenges to Commute.org's ability to add new members and the effort was stalled. Commute.org has since determined that AB 1912 will not present an issue and have included in their new Strategic Plan the goal to "complete the alliance" to bring in the remaining non-member jurisdictions. They are prepared to draft Memorandums of Understandings (MOUs) with each city in the first quarter of Fiscal Year 2021 (July-September 2021).

The City would be asked to appoint a City Councilmember (and an alternate) to participate on the Commute.org Board of Directors, which would require up to eight additional hours per month of Councilmember attendance at meetings or City Staff time should City Council ask Staff to participate in one of the organization's Advisory Committees.

With representation on the Board, the City would have the ability to help guide the development of the organization’s Strategic Plan and annual Work Plans, ensuring that the agency’s programming and services are aligned with the city’s transportation goals and plans, and connect with peer cities and agencies.

**Table 3 Action 1 Cost & Benefit Summary**

Action	Cost	Benefit
<ul style="list-style-type: none"> <li>Appoint member of City Council to Commute.org Board of Directors</li> </ul>	<ul style="list-style-type: none"> <li>No direct cost</li> <li>Up to 8 hrs/month of Councilmember or City Staff time</li> </ul>	<ul style="list-style-type: none"> <li>Increased ability to guide countywide TDM implementation to support City needs</li> <li>Increased ability to coordinate TDM efforts with cities in San Mateo County</li> </ul>

*Action 2: Encourage employers to participate in Manzanita Works’ Ravenswood Transit Consortium*

The City should encourage businesses with the means to join Manzanita Works’ Ravenswood Transit Consortium to do so through efforts such as:

- Connecting employers with transportation questions to the Manzanita Works team;
- Inviting the Manzanita Works team to present at City informational or committee meetings on a regular basis; and
- Where appropriate, requiring Ravenswood Transit Consortium membership in Conditions of Approval and similar conditions as part of the entitlement process.

Members of Ravenswood Transit Consortium have access to transit benefits, including shuttle service, outreach support, and transportation counseling. By encouraging businesses to join, the City would be pushing for more standardized and consistent TDM implementation and reporting among employers. In addition, these employers would benefit from gaining access to regional stakeholders to share best practices and identify partnership opportunities.

**Table 4 Action 2 Cost & Benefit Summary**

Action	Cost	Benefit
<ul style="list-style-type: none"> <li>Informally encourage Manzanita Works membership by increasing the organization’s visibility</li> <li>Where feasible, require that new projects commit to joining Manzanita Works</li> </ul>	<ul style="list-style-type: none"> <li>No direct cost for City</li> <li>Cost associated with membership for employers to be agreed upon with Manzanita Transit</li> </ul>	<ul style="list-style-type: none"> <li>Increased regional and sub-regional collaboration for Menlo Park employers</li> <li>Improved standardization among site-based programming offered across City</li> </ul>



#### 4.2.2 Position the City as an example of a robust employer program

The City currently provides transportation benefits to encourage its employees to use non-drive alone modes to commute to work, including a \$75 commuter check for additional transit costs, which has been temporarily increased to \$150, \$1.50 per day transportation allowance for biking, walking, or carpooling to work as primary modes, on-site employee bikeshare, as well as two-week trial loans of e-scooters/e-bikes. Prior to the COVID-19 pandemic, the City participated in the Caltrain Go Pass Program to provide employees with free rides on Caltrain. However, due to the state-wide Stay at Home order last year and with employees working from home, the City has suspended the program for the time being and plan to reassess next year.

As an employer in San Mateo County, the City also leverages and promotes several of Commute.org's services to its employees:

- Promotion of Commute.org's incentives program to reward employees for every sustainable commute trip and as part of large annual events such as the Commuter Challenge;
- Distribution of Commute.org materials (e.g. brochures, flyers, etc.) as part of New Hire Orientation and annual Employee Health Fair; and
- Guaranteed Ride Home Program.

The City has the opportunity to serve as a model providing an enhanced Commuter Benefits Program for its employees. By fully leveraging and collaborating with TDM partners, the City will be able to lead by example as it encourages other Menlo Park employers to do the same.

##### *Action 3: Promote Commute.org's full suite of services to its employees*

Given the full suite of services available to the City free of charge of Commute.org (see Section 3.2.1), the City should consult with Commute.org to identify ways to better leverage and promote Commute.org's services and programs. For example, the City could promote Commute.org's Vanpool and Carpool Programs, which provides incentives for commuters to start or join new vanpool or carpool, on the City's intranet and as part of New Hire Orientation. In addition, the City would also direct employees to Commute.org's STAR platform which can be used to find carpool, vanpool, and bike partners.

Acknowledging that Staff have limited capacity to actively promote these services year-around, there may be opportunities for Commute.org to assist the City putting forth a one-time effort (e.g., incorporating its full suite of services into the City's intranet) or developing a regular schedule for promotions (Commute.org could plan to host or participate in one event a year to raise awareness of the organization and educate employees on their options). The goal would be to make employees aware of their commuter options and benefits with minimal additional administrative burden placed on the City. The City should work with Commute.org to explore this opportunity.

**Table 5 Action 3 Cost & Benefit Summary**

Action	Cost	Benefit
<ul style="list-style-type: none"> <li>Consult with Commute.org on opportunities to offer more Commute.org services to City employees</li> </ul>	<ul style="list-style-type: none"> <li>While Commute.org’s services are free of cost to the City, additional City Staff time may be required to expand and actively promote the services.</li> </ul>	<ul style="list-style-type: none"> <li>Enhanced Commuter Benefits Program to its employees may serve to encourage behavior change and reduce parking demand on City lots while also serving as an example of a Menlo Park employer investing in commuter benefits to help employees reduce their reliance on their vehicles.</li> </ul>

*Action 4: Join Manzanita Works’ Ravenswood Transit Consortium as an Employer*

Based on the City’s assessment of transportation benefits in a post-COVID environment, the City could decide to either repurpose a portion of City funds currently dedicated to transportation benefits (e.g., the Caltrain Go Pass) or expand funding to in order to join Manzanita Works’ Ravenswood Transit Consortium. As a member of the Ravenswood Transit Consortium, the City would have a “seat at the table” to participate in the sub-regional organization (which encompasses the Mid-Peninsula from Sunnyvale to Redwood City) as well as the wider regional discussions regarding ways to improve the quality of life for employees, including improving access to transportation options. This congregation of public and private sector employers provides not only an opportunity to guide TDM implementation in the region but to also identify cost efficiencies and collaboration opportunities, such as shared shuttle service. It is important to note that because the City is joining as an employer, only the City staff would have access to the organization’s services.

**Table 6 Action 4 Cost & Benefit Summary**

Action	Cost	Benefit
<ul style="list-style-type: none"> <li>When ready, join the Ravenswood Consortium to supplement services for employees</li> </ul>	<ul style="list-style-type: none"> <li>\$40,000 annual member dues for the City of Menlo Park to join as a public agency.</li> </ul>	<ul style="list-style-type: none"> <li>Access to additional mobility options and services, such as the essential workers shuttle service, for City employees.</li> </ul>

### 4.2.3 Ensure TDM Support is Available for All Businesses

Based on feedback received from the Chamber of Commerce, interviews with small business employers, and a survey to employees of small businesses gathered in Fall 2019, both employers and employees have expressed an interest in receiving more support for the provision of transportation information and resources as well as marketing assistance (see Figure 6)**Error! Reference source not found.** When asked, many were not aware of the fact that these services were already available free of charge from Commute.org or through a membership with Manzanita Works.

Figure 6 “How useful would the following services be to you?” Survey Response

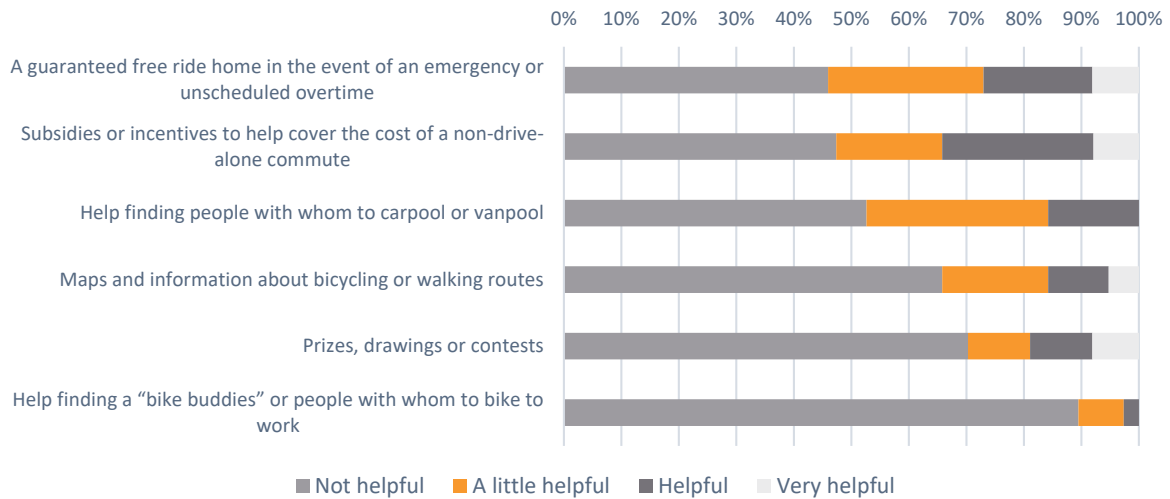

Since these services are already available to Menlo Park employers, the remaining gap lies in raising awareness and connecting employers to these organizations. The City should focus on ensuring businesses understand the TDM services and resources they have available to them, especially as employers navigate the changing work schedule and commuting patterns, long-term work from home policy, and mode preferences related to recovery from the COVID-19 Pandemic.

*Action 5: Invest in existing sub-regional resources to provide targeted Citywide support*

As uncovered during stakeholder interviews, many small businesses are not able to offer TDM benefits to their employees, either due to the lack awareness of available resources or the capacity to manage a TDM program internally. While the City could choose to manage these education and engagement efforts itself, it would be most cost-effective to partner with the organizations like Manzanita Works and Commute.org to provide more dedicated support to Menlo Park businesses. This would allow for economies of scale and extend the City’s reach by tapping into each organizations’ resources and network while minimizing any potential confusion for employers as it relates to the different organizations they should work with.

Both Manzanita Works and Commute.org offer resources and services to help employers in their efforts to meet TDM and sustainability goals and employees choose non-drive alone modes of

travel. Therefore, it is recommended that the City consider partnerships with both organizations to provide TDM support to Menlo Park businesses. Following a comprehensive review of the transportation needs and priorities within the city post COVID-19 pandemic, the City should work with both organizations to identify potential partnership opportunities. For example, the City could commission both organizations to provide dedicated employer support to Menlo Park employers in a way which leverages each organization's unique offerings to maximize the TDM support and opportunities for employers. Alternatively, the City could elect to commission specific services from either organization for a fee. This would also be affected by the funding available and should allow for annual evaluation and adjustment to the scope.

Moreover, as Commute.org and Manzanita Works are exploring collaboration with each other, the City should consult with both organizations regularly to engage and provide employers in Menlo Park with coordinated TDM outreach and education support.

These partnerships may include both short and long-term strategies such as:

**Short-Term/High-Priority:**

- Working with the City to identify target employers for engagement;
- Educating employers lead contacts on TDM programs and services available to them;
- Consulting with employers to get them to provide enhanced benefits to employees;
- Assisting with Bay Area Commuter Benefits Program compliance (for employers with 50+ employees);
- Distributing Caltrain GO Passes to small and medium-sized employers; and
- Providing first/last mile shuttle services;

**Long-Term/Low to Medium Priority:**

- Developing an engagement strategy for varying tiers of employers, including paid local advertising, direct mail, telemarketing, and canvassing;
- Identifying opportunities to incentivize engagement and program performance measures;
- Assisting with survey development, administration, and analysis;
- Hosting online and in-person (when appropriate) forums for TDM program promotion;
- Developing customized monthly newsletters to include local content;
- Participating in the Caltrain Go Pass donation program; and
- Taking advantage of regional coordination and partnerships on new mobility services.

It is recommended that the City continue conversations between City Staff and staff from both Manzanita Works and Commute.org to identify potential opportunities for formal partnerships between the City and both organizations. When appropriate, it is recommended that the City consider an investment between \$30,000 - \$120,000 to provide TDM services for the estimated 20,000 employees within the city. This is based on examples from comparable cities in California (such as San Francisco, Palo Alto, Santa Monica, and Glendale) providing TDM services directly or through a TMA. The range is dependent on the amount of TDM services provided as well as the amount of oversight and involvement by the cities.

**Table 7 Action 5 Cost & Benefit Summary**

Action	Cost	Benefit
<ul style="list-style-type: none"> <li>Meet with Manzanita Works and Commute.org at least quarterly</li> <li>When appropriate, invest in paid partnerships with regional/subregional organizations to provide dedicated support to Menlo Park small and medium-sized businesses.</li> </ul>	<ul style="list-style-type: none"> <li>\$30,000 - \$120,000 recommended annually</li> </ul>	<ul style="list-style-type: none"> <li>Improved access to TDM services for employers that need it</li> <li>Increased sub-regional collaboration and ability to hear from smaller businesses</li> </ul>

### 4.3 Summary of Recommended Actions

The objectives and actions described in detail above have been summarized in the below table.

**Table 8 Summary of TDM Objectives and Recommended Actions**

Objective	Action
<b>Endorse regional TDM efforts</b>	Action 1: Join Commute.org JPA
	Action 2: Encourage employers to participate in Manzanita Transit
<b>Position the City as an example of a robust employer program</b>	Action 3: Promote Commute.org’s full suite of services to its employees
	Action 4: Join Manzanita Transit to supplement existing employee commuter benefits
<b>Ensure TDM support is available to all businesses</b>	Action 5: Invest in existing sub-regional resources to provide targeted Citywide support

# 5 Next Steps

Due to the COVID-19 pandemic, there is uncertainty surrounding when businesses will return to the office, how employees will commute to work, and priorities and available budget for the City, which all factor into how the City would implement the strategies outlined in this document. The Project Team has identified both short and long-term steps needed for the City to continue to advance and implement the actions outlined in Section 4.

These include:

- Understanding post-COVID needs and priorities
- Identifying long-term funding sources for TDM
- Implementing the short-term actions outlined in Figure 7 above.

## 5.1 Implement Short-Term Strategies

Some of the recommended actions identified in this document are able to be carried out for either low or no cost or have already been partially initiated. Therefore, the City should consider implementing the strategies identified below as 'low hanging fruit' within the 2022-2023 FY.

Those strategies include:

- City joining the Commute.org JPA
- City connecting employers and developers to Manzanita Works during the development/redevelopment process
- City promoting Commute.org's services to its employees, employers, and residents
- City promoting Manzanita Works' services to its employees, employers, and residents

The City could also consider engaging with Manzanita Works on one or several studies or projects before it considers how a longer-term partnership could look, such as:

- Bike-loaner program feasibility study (cost: \$10K)
- Subregional bike share feasibility study (cost: \$25K)
- Outreach to employers to understand economic and community impacts of COVID-19 (cost: TBD based on scope). Manzanita Works is currently doing a similar outreach on behalf of the City of Redwood City.

## 5.2 Understand Post-COVID Needs and Priorities

### 5.2.1 Comprehensive Study

While an initial analysis of Streetlight data and interviews with employers were conducted as part of this effort, in light of the COVID-19 pandemic and the potential changes in travel patterns, it is recommended that the City conduct a comprehensive market research to better understand how

citywide travel behavior have changed. Similar to how the City will reassess its own participation in the Go Pass program, as businesses return to the office, this data will also help the City understand how community needs and priorities, traveling patterns, and current transportation options have changed as a result of the pandemic. This data will also form the baseline to measure the impact of the various strategies proposed in this document as well as identify key corridors and modes to target for intervention. The Comprehensive Study may be conducted in various forms:

#### *Survey*

A market research survey of employees working in Menlo Park would provide insight about how their commute patterns have changed, their main challenges and concerns with commuting to work, and how the City/their employers could support them. The citywide survey could be administered by a division within the Community Development Department (i.e., Transportation with input from Planning and Economic Development, etc.) or in partnership with the Chamber of Commerce, Commute.org, or another third party.

#### *Streetlight Data*

As part of the TMA Feasibility Study, Streetlight data was obtained and analyzed in 2019 to understand travel habits throughout the city. Using anonymized data from smartphones and navigation devices, the four Focus Area Zones (Northern, Central, Downtown, and Southern) were analyzed for trip origin and destination by Census Block Group. For example, Northern Menlo Park, home to some of the city's largest employers, contributed to the most trips and followed a traditional commute-style pattern with more trips coming into the zone in the morning peak (6am – 10am) and leaving during the even peak (3pm – 7pm), with significant volume coming from across the Dumbarton Bridge. On the other hand, the Central and Downtown Focus Area Zones which includes many public facilities and small retail establishments, respectively, experienced more in trips in the evenings and with many trips originating within a 2-3-mile radius.

While this provided valuable insights into the travel patterns throughout the City, due to the COVID-19 pandemic and its impact on travel patterns, another analysis is recommended using updated Streetlight Data.

#### *Trip Tracking Technology*

In addition to anonymized smartphone data traveling into and out of the city, the City also has the option to gather individualized travel data through various technology platforms. The Miles reward applications, for example, rewards users who sign up and enable location-sharing for every mile travelled, with higher points awarded to sustainable modes such as biking, walking, and transit. By partnering with Miles, the City could provide incentives and rewards to encourage Menlo Park employees to participate.

Alternatively, the City could partner with Commute.org to promote its STAR platform and Commute Tracker app where participants can earn points for each commute trip logged. While the Miles app allows for passive tracking, which increases the likelihood of users signing up and the amount of data gather, leveraging an existing platform through Commute.org could require less work on the City's part.

## 5.3 Identify Funding Sources

Some of the recommended strategies identified in Section 4 include monetary contributions from the City. Below are several options for further consideration and exploration by the City:

### 5.3.1 Shuttle Program Recommendations

The City currently manages four shuttle routes, two of which serve to connect the business parks along Marsh Road and Willow Road with the Caltrain station during commute hours. The City is interested in conducting a shuttle assessment study related to route optimization. As part of that study, there is an opportunity to consider alternative uses, cost-efficiencies with privately-operated shuttles, and review the fee structure. For example, if it has been determined that there is an existing privately-operated shuttle which could serve the same group of commuters, the study could explore the ability to partner with the operator to run a single, joint shuttle and reallocate the funds toward other TDM efforts.

### 5.3.2 Grant Opportunities

Federal, state, and regional grants are also viable sources of funding. Based on the grant stipulations, the funds could be used for additional analysis, the launch of a new program, or towards incentives and subsidies. For example, the City is currently tracking Caltrans Planning Grants that may be used toward the Comprehensive Study.

### 5.3.3 Adjusted Parking Revenue

Based on a 2016 Parking Study of Downtown Menlo Park, there are a total of 1,602 parking spaces in Downtown, including 405 on-street and 1,197 off-street spaces. While most are not metered, 395 of the three-hour spaces in Plazas 1 and 5 may be used for a longer duration for a fee: \$1 per hour after the first three hours. Two types of parking permits are available: annual permits and temporary (daily) permits. As of 2016, 685 annual permits were available for purchase at \$592 and temporary permits cost \$10 per day. Since 2018, annual and day permit purchases have been on a downward trend, with 2020 being exceptionally low due to the suspension of parking enforcement due to the COVID-19 pandemic.

During the Existing Conditions process the Project Team asked small business representatives questions about their primary challenges to commute to work and their employee commute habits. Parking was identified as the second most important challenge for employees after traffic. Employees cited that parking is an issue for not only customers but also themselves as they oftentimes must decide between looking for a space in the neighborhood (which can be difficult) or in the on- and off-street lots with temporary free parking (which means they must move their vehicles every two or three hours). The high cost of an annual pass is also cost prohibitive for many retail and hospitality workers working in Downtown.

The City could consider undertaking another Parking Study to identify possible revenue streams to help fund TDM efforts within the City. Potential areas to consider include the feasibility of expanding permitted spaces or providing daily passes for employees which would generate revenue and open up the free parking spaces for customers, increasing the cost of a temporary permit, or adding meters to on-street spaces. This will be especially useful as the City undertakes



the planned maintenance and construction of several existing parking plazas. As a result, parking revenue will be needed for parking lot maintenance as well as for TDM going forward.

## 5.4 Revise TDM Program Guidelines

Many large developments in the city are subject to TDM Plan requirements through environmental mitigation measures, conditions of approval for compliance with the Zoning Ordinance, Specific Plan, or TDM program guidelines, and/or negotiated requirements as part of a development agreement. These requirements range from the provision of shuttles to the installation of bike racks and lockers. While existing plans cannot be altered, there is an opportunity to revise the TDM program guidelines and Menlo Park Municipal Code.

The City's TDM program guidelines are due for a revision since its last release in 2015. These guidelines are based on C/CAG's TDM guidelines, which is currently in the process of revising their guidelines. Revisions could include recommending joining a TMA or other regional transportation organization (as approved by the Public Works Director or designee). Additionally, C/CAG is investigating a tier system that may award more points for joining a TMA based on a development's size and/or type. Compared to the current system where five peak hour trips are credited to anyone who joins a TMA, this tier system incentivizes joining a TMA where benefits are greater to the development.

The Municipal Code has specific TDM guidelines for the Office (Chapter 16.43), Life Sciences (Chapter 16.44), and Residential Mixed Use (Chapter 16.45) Districts, where developments of 10,000 or more square feet must reduce vehicle trips by at least 20 percent. Participating in a TMA is an option to reduce vehicle trips, but language could be changed so that participation in a TMA or other regional transportation organization (as approved by the Public Works Director or designee) is a requirement for all new, future developments within these zones. In the meantime while the Municipal Code is being updated, conditions of approval could include language requiring participation in a TMA for developments subject to the TDM ordinance.

## 5.5 Consider Implementation Plan for Long-Term Actions

For the recommended actions which have associated costs or require the City to enter into contractual commitments, it is recommended that the City take a more cautious 'wait-and-see' approach. In addition to the impacts of the pandemic, regional organizations such as Manzanita Transit and Commute.org are still evolving and changing to respond to the post-COVID environment. As such, it would be prudent for the City to remain apprised of each organization's plans while it similarly conducts a comprehensive review of the new travel habits, needs, and challenges for employers and employees in Menlo Park. The City should then engage with both organizations to explore partnership opportunities.

## 5.6 Expected Timeline

Below is the proposed timeline for implementation of the actions outlined in this report.

Figure 7 TDM Implementation Timeline

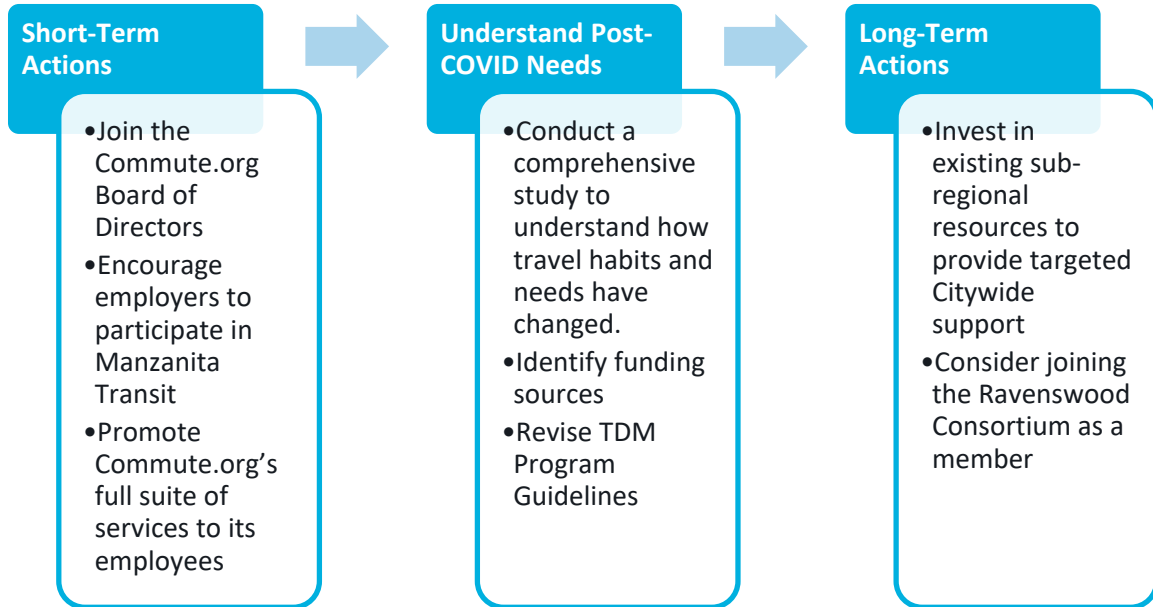

Table 9 Yearly Ramp Up Schedule

Year	Fiscal Year	Recommended Policy	Amount
1	2021-2022	Implement Short-Term Actions	Current TDM services budget + cost to reinstate Caltrain Go Pass (or equivalent service) + cost to implement short-term actions
2	2022-2023	Understand post-COVID needs	Year 1 budget + budget for additional consultant services, if needed
3	2023-2024	Explore Long-Term Actions	Year 2 budget + cost for long-term actions

## 6 Conclusion

Because the City of Menlo Park recognizes the value of TDM in mitigating congestion, reducing GHG emissions, and improving the quality of life for its employees, the City commissioned a study on how it could best advance TDM throughout the city. While the initial intent was to create a Transportation Management Association (TMA), the study identified the availability of several TDM services with existing presence within the city as well as the launch of a new regional TDM initiative. Therefore, it was determined that it would be most cost-effective and impactful for the City to partner with these existing organizations and dedicate its time and resources toward promoting and connecting employers to these existing services.

The study identified several key objectives as well as actions the City can undertake to advance TDM within and throughout the City. They are summarized in Table 10.

**Table 10 Summary of TDM Objectives and Recommended Actions**

Objective	Action
<b>Endorse regional TDM efforts</b>	Action 1: Join Commute.org JPA
	Action 2: Encourage employers to participate in Manzanita Transit during the development/redevelopment process
<b>Position the City as an example of a robust employer program</b>	Action 3: Promote Commute.org’s full suite of services to its employees
	Action 4: Join Manzanita Transit to supplement existing employee commuter benefits
<b>Ensure TDM support is available to all businesses</b>	Action 5: Invest in existing sub-regional resources to provide targeted Citywide support

Several actions may be taken immediately, such as joining the Commute.org JPA or encouraging employers to participate in Manzanita Transit, because the City has either already initiated those efforts or they wouldn’t require additional funding or resources. Other actions, such as for the City to partner with Commute.org and Manzanita Works to provide citywide TDM support, would require additional research and consideration. Due to the unprecedented impacts of the pandemic, additional studies would help the City understand how commute patterns and transportation needs have changed and how the City would best work with both organizations to address those changes.

## Control Information

**Prepared by**

Steer  
800 Wilshire Blvd, Suite 1320,  
Los Angeles, CA 90017  
USA  
+1 (213) 425 0990  
www.steergroup.com

**Prepared for**

City of Menlo Park  
701 Laurel St.,  
Menlo Park, CA 94025

**Steer project/proposal number**

23642101

**Client contract/project number****Author/originator**

Jenny Hong

**Reviewer/approver**

Julia Wean

**Other contributors****Distribution**

Client: City of Menlo Park Steer:

**Version control/issue number**

4.1

**Date**

9/16/2021



# Menlo Park TMA Feasibility Study

City Council Update, September 21, 2021



**steer**

# Agenda

---

1. Project Background
  - Existing Conditions
  - Options Analysis
2. Recommendations
3. Implementation Plan
4. Next Steps

# Project Background

---

## Phase 1: Existing Conditions

*September 2019-January 2020*

- Stakeholder Outreach
  - One-on-one interviews
  - Small business drop-ins
  - Online employee survey
  - On-site tabling
- Travel Data Analysis (Streetlight Data)
  - Four areas or “zones” within the City of Menlo Park.
  - Each zone faces unique challenges

## Phase 2: Options Analysis

*January-July 2020*

- Review of potential TMA models based on cost and opportunity:
  - VMT reduction
  - Mode shift
  - Stakeholder reach
  - Employee reach

## Phase 3: Implementation Plan

*July 2020-Present*

- Determine preferred model and recommendations
- Identify potential funding sources
- Outline City involvement/engagement



# Project Background: Existing Conditions

- Edge of county location challenges transit access
- Inconsistencies in TDM requirements at site-level create duplication of services
- Most-demanded services already available; need relates to education/information

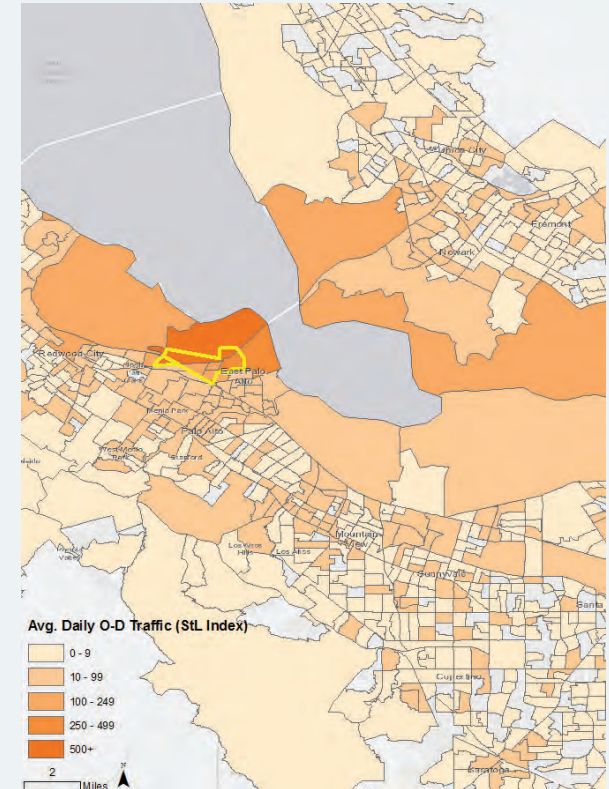
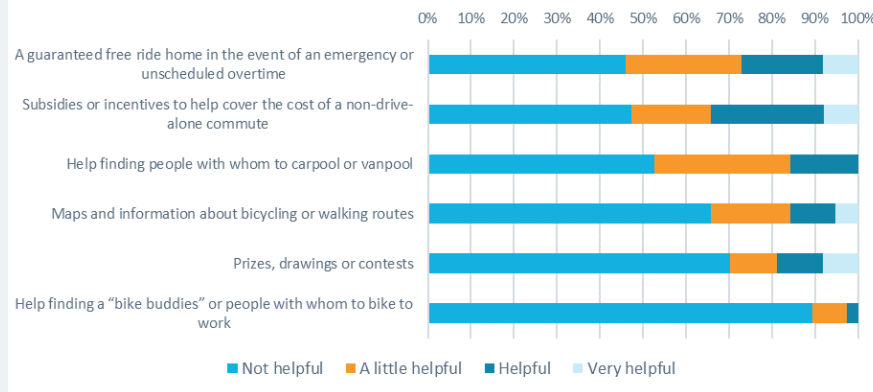

# Project Background: Options Analysis

## Models selected by City Council (July 2020)

Subregional

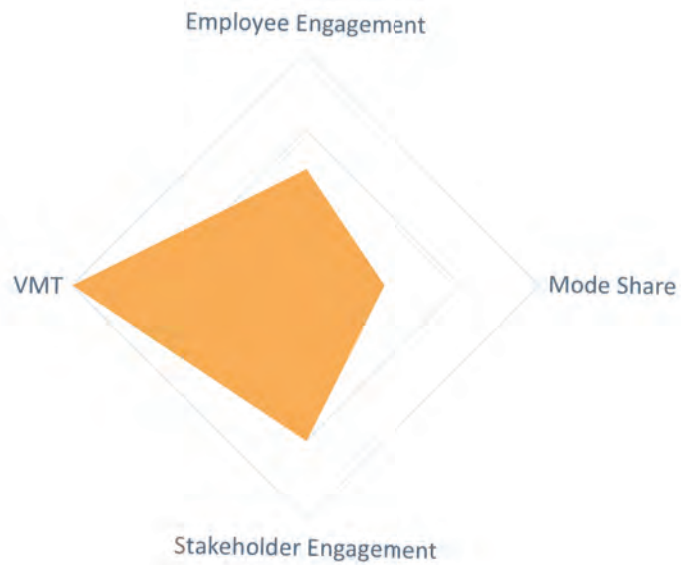

Citywide

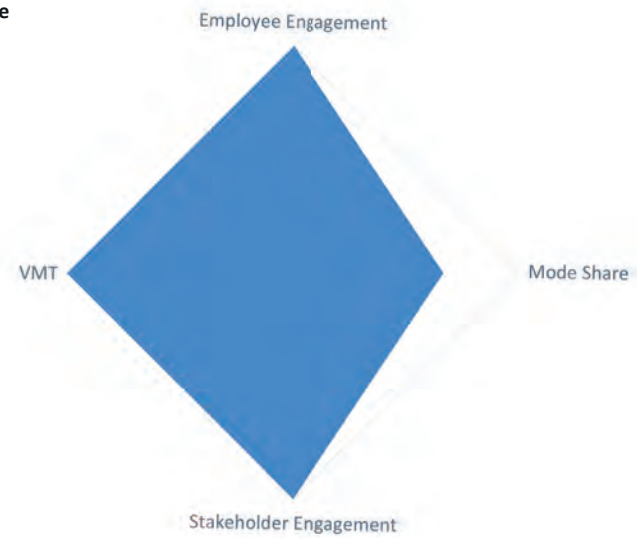

# Project Background: Options Analysis

---

## Changing TDM Landscape

- COVID-19 Pandemic has caused employers to be more cost-conscious
- *Manzanita Works and the Manzanita Transit Ravenswood Consortium* is officially up and running; our team has a better understanding of their offer and business model

## Concerns with original TMA Models

### Subregional:

- City can't join on behalf of all employers
- Investment in membership may be more difficult for employers than it was before COVID-19 Pandemic

### Citywide:

- A separate citywide TMA, if asking for membership dues, is likely to duplicate services already offered by Manzanita Works and Commute.org.
- Investment in membership may be more difficult for employers than it was before COVID-19 Pandemic

## Existing Regional/Subregional TDM Organizations

---



- Non-profit organization supporting workers in the Bay Area, with Manzanita Transit focusing on regional transportation issues
- Membership-based employer-led consortiums across the region allow for sub-regional specific collaboration
- Long-haul shuttle pilot between south and east-bay locations and East Palo Alto for essential workers
- Transportation program consultation, outreach, education
- Partnerships and advocacy through consortium connections
- Connects members and others with existing resources
- Collaborates with Caltrain on GoPass distribution
- Exploring programming such as Guaranteed Ride Home and vanpool support

## Existing Regional/Subregional TDM Organizations

---



- San Mateo County's Transportation Management Agency
- Provides TDM services for free to all who live or work in county:
  - Guaranteed Ride Home
  - Carpool and vanpool ridematching
  - Carpool and vanpool subsidies
  - Free Transit Ticket program
  - Rewards and Incentives
  - Education materials
- All Commute.org services offered for free, but City can join Commute.org Board to support subregional partnerships (most jurisdictions in the County are represented)

# Recommendations

---



steer

# Collaboration with local committees and organizations

---

Original recommendations presented to Complete Streets Commission April 2021

- Appreciation for value brought to the City by current TDM organizations
- Openness to the idea of investing in TDM for the City
- Concern with committing to financial investment immediately given uncertainty
- Interest in learning more given COVID-19 sizable impact on travel

Subsequent revision of recommendations included collaboration between City, consultant team, Manzanita Works and Commute.org

- Meeting with both organizations
- Discussion surrounding collaboration between them
- Opportunities for both organizations to review updated recommendations

## Recommendations: Objectives

---

1. Endorse and support regional and sub-regional TDM efforts

---

2. Position the City as an example of a robust employer program

---

3. Ensure TDM support is available to all businesses



# Recommendations

## Objective 1: Endorse and support regional and subregional TDM efforts

### Action 1: Join Commute.org Board of Directors:

- City Council representative and alternate to participate on Board and in Advisory Committees

<b>Cost</b>	No direct cost to City, estimated 8 hours time per month
<b>Benefit</b>	<ul style="list-style-type: none"><li>• Increased buy-in from community, ability to encourage support for city-specific needs</li><li>• Increased collaboration with other jurisdictions already participating</li></ul>

### Action 2: Encourage employers and developers to participate in Manzanita Works' Ravenswood Transit Consortium

- Endorsement of Manzanita Works as a valuable asset to employers and property managers
- Consider outlining recommendation to join TMAs in Conditions of Approval, Development Agreements, etc.

<b>Cost</b>	No direct cost to City
<b>Benefit</b>	<ul style="list-style-type: none"><li>• Collaboration between City and sub-regional stakeholders better supports needs of commuters</li><li>• Improved standardization among site-based programming offered across the City</li></ul>

# Recommendations

## Objective 2: Serve as an example of an employer with a robust and collaborative TDM program

### Action 3: Promote Commute.org's full suite of services to City employees

- Promote free Commute.org services (i.e. vanpool subsidies, bicycle/pedestrian support) to City of Menlo Park employees
- Consult with Commute.org to identify opportunities for further engagement

<b>Cost</b>	No direct cost to City; potential staff time involved in outreach and event attendance
<b>Benefit</b>	Employees more likely to take advantage of pre-existing programs

### Action 4: City Joins Manzanita Works' Ravenswood Transit Consortium as an employer

- City pays to join as an employer member to supplement current employee benefits
- Employees have access to services offered by Manzanita Transit (i.e. essential workers shuttle services)

<b>Cost</b>	\$40,000 Annually
<b>Benefit</b>	<ul style="list-style-type: none"><li>• One-on-one support for City employees</li><li>• Ability for City to have 'seat at the table' within consortium</li></ul>

# Recommendations

## Objective 3: Ensure TDM support is available for all businesses

### Action 5: Invest in existing sub-regional resources to provide targeted Citywide Support

- Short term – meet with Manzanita Works and Commute.org representatives at least quarterly
- Longer term – invest in paid partnerships Manzanita Works and Commute.org to provide dedicated support to Menlo Park businesses

<b>Cost</b>	\$30,000 - \$120,000 annually
<b>Benefit</b>	<ul style="list-style-type: none"><li>• Improved access to TDM services for employers who need it</li><li>• Increased regional and subregional collaboration</li></ul>

# Implementation Plan

---



# Implementation Plan

## Implementation Process: Short Term

### 1. Implement Short Term Actions

*(2021-2022)*

Implement low/no cost strategies including:

- Join the Commute.org Board
- Connect employers/projects to the Ravenswood Transit Consortium
- Actively promote free TDM services and programs among City staff.
- Consider low-commitment engagement with Manzanita Works

### 2. Understand Post-COVID Needs/Priorities

*(2022-2023)*

Undertake further assessment to understand how needs have shifted in past 18 months. Options may include:

- Market research survey of Menlo Park employees and/or residents, or survey specifically geared at City staff
- Employ trip tracking technology (i.e. Miles) and incentivize use to receive trip-level data
- Conduct updated and continuous Streetlight Data analysis

### 3. Identify Funding Sources

*(2023)*

Prior to undertaking TDM efforts with associated cost, the City must identify sources for funding. Suggestions include:

- Utilizing forthcoming shuttle assessment to identify cost efficiencies that could be repurposed
- Apply for grant opportunities (i.e. Caltrans Planning Grant)
- Consider study of current parking pricing and policy to identify revenue streams for TDM
- Other funding opportunities

# Implementation Plan

## Implementation Process: Medium-Long Term

### 4. Revise City TDM Guidelines

*(2023-2024)*

Adjust City guidelines for new projects/developments (current guidelines from 2015):

- Align with forthcoming C/CAG guidelines
- Consider benefits or requirements for joining TMAs or similar organizations
- Consider adopting tiered system if consistent with C/CAG

### 5. Consider Long-Term Actions

*(2023-2024)*

Based on regular check-ins with regional/subregional organizations, identify path forward for long-term investment in City-specific TDM services

- Join Ravenswood Transit Consortium as an employer
- Work directly with Manzanita Works and Commute.org to solicit dedicated support for Menlo Park

# Next Steps

---

steer

# Recommendations

We request that you adopt the final TMA Feasibility Study today.

## Immediate Actions

1. Implement Short Term Actions
  - Join Commute.org Board
  - Support and provide connections between Manzanita Works and new projects/employers
  - Expand upon free services promoted to City Staff
2. Undertake research to better understand post-COVID needs
3. Identify funding sources for future activities

## Long Term Actions

1. Revise City TDM guidelines
2. Undertake Long-Term Actions as appropriate:
  - Join the Ravenswood Transit Consortium as an employer
  - Work with existing TDM organizations to invest in dedicated support in Menlo Park



# Thank you!

---

Nick Yee

Project manager

[Ngjee@menlopark.org](mailto:Ngjee@menlopark.org)

Julia Wean

Consultant project manager

[Julia.wean@steergroup.com](mailto:Julia.wean@steergroup.com)

**DISCLAIMER:** This work may only be used within the context and scope of work for which Steer was commissioned and may not be relied upon in part or whole by any third party or be used for any other purpose. Any person choosing to use any part of this work without the express and written permission of Steer shall be deemed to confirm their agreement to indemnify Steer for all loss or damage resulting therefrom.



## STAFF REPORT

### City Council

Meeting Date:

9/21/2021

Staff Report Number:

21-187-CC

Regular Business:

**Adopt resolution amending the City Council approved salary schedule effective September 21, 2021**

### Recommendation

City staff recommends that the City Council adopt Resolution No. 6669 amending the City Council approved salary schedule effective September 21, 2021:

Staff recommends adding four positions to the salary schedule

- Finance Director
- Enterprise Applications Administrator
- Systems Administrator
- Engineering Services Manager

Staff recommends removing one position from the salary schedule

- Engineering Services Manager/City Engineer

The recommendation results in no change in full-time equivalent (FTE) personnel.

### Policy Issues

The City Council retains sole authority to amend the salary schedule and budget for FTE personnel.

### Background

The City of Menlo Park's (City) salary schedule identifies job classifications that have been approved by City Council (e.g., accountant, administrative assistant) and the annual salaries by step for classifications represented by a bargaining unit and by open range for unrepresented classifications. Salary ranges are subject to the meet and confer process. Annual salaries for new classifications established during a closed contract is set using internal alignment. Internal alignment analyzes the scope of responsibilities and skill required of the new classification and set the salary at the same level as an existing classification. In 2018, the City aligned all unrepresented management classifications to a salary schedule based on the classification's scope of duties, span of control, and skills required.

### Analysis

City staff recommends the following modifications to the City Council adopted salary schedule with an effective date of September 21, 2021:

#### Finance Director

Staff turnover in the finance division of administrative services has heavily impacted the division's management. In 2020, the City's administrative services director separated from the City and the position

was eliminated in the 2020-21 budget process. In the absence of a department head overseeing finance, human resources, and information technology, management upgraded the incumbent finance and budget manager to assistant administrative services director. In July 2021, the assistant administrative services director separated from the City, transferring the City's executive financial management responsibilities to the assistant city manager. Reliance on the assistant city manager to serve as the City's chief financial officer is not sustainable. City staff recommends adding the finance director classification to the salary schedule, thereby allowing a competitive recruitment for an interim municipal finance executive to serve as a chief financial officer by November 2021. The interim appointment provides time to review the administrative services department's leadership and management needs before recruiting for a regular department head position. City staff recommends aligning the new classification with the department head salary range of \$160,316 to \$227,436.

#### Enterprise Applications Administrator and Systems Administrator

As two complementary classifications, the proposed additions formalize an existing organizational structure for the City's information technology division. The enterprise applications administrator specializes in managing and integrating the City's enterprise and business applications such as land management, geographic information systems, financial accounting, budgeting, etc. The systems administrator classification provides specialized skills supporting systems that enable end-user productivity across the organization, including telecommunications, desktop operating systems, and, most importantly, cybersecurity. City staff recommends aligning both classifications with the senior management analyst salary range of \$114,894 to \$138,502.

#### Engineering Services Manager

The Engineering Services Manager/City Engineer is an assistant department head level position that was replaced when the assistant public works director – engineering classification was created. City staff recommend deleting the engineering services manager/city engineer classification and adding the engineering services manager classification to provide a management classification below the assistant director. City staff recommends aligning the classification with the division manager salary range of \$126,553 to \$170,578, a decrease from the engineering services manager/city engineer salary range of \$140,650 to \$181,949.

The new classifications do not increase headcount. Existing personnel will be reclassified to systems administrator and enterprise applications administrator to align their title with current duties.

#### **Impact on City Resources**

The recommend classification changes result in no increase in employee headcount and existing and new employees are only impacted if their job assignments fall within the new job classifications.

#### **Environmental Review**

This action is not a project within the meaning of the California Environmental Quality Act (CEQA) Guidelines §§ 15378 and 15061(b)(3) as it will not result in any direct or indirect physical change in the environment.

#### **Public Notice**

Public notification was achieved by posting the agenda, with the agenda items being listed, at least 72 hours prior to the meeting.

**Attachments**

A. Resolution No. 6669

Report prepared by:  
Nick Pegueros, Assistant City Manager

## RESOLUTION NO. 6669

**RESOLUTION OF THE CITY COUNCIL OF THE CITY OF MENLO PARK  
AMENDING THE SALARY SCHEDULE EFFECTIVE SEPTEMBER 21, 2021**

WHEREAS, pursuant to the Personnel System Rules, the City Manager prepared a Compensation Plan;

WHEREAS, City Council adopted Resolution No. 6637 establishing the current salary schedule effective July 4, 2021 at their June 28, 2021 special meeting; and

NOW, THEREFORE BE IT RESOLVED that the following compensation provisions shall be established in accordance with the City's Personnel System rules.

BE IT FURTHER RESOLVED that any previous enacted compensation provisions contained in Resolution No. 6637 remain with the modifications as provided in Table 1:

Table 1: Salary schedule modifications					
Classification title	Minimum/ Step A	Step B	Step C	Step D	Maximum/ Step E
<del>Engineering Services Manager/City Engineer</del>	<del>\$140,650</del>		<del>Open range</del>		<del>\$181,949</del>
Engineering Services Manager	\$126,553		Open range		\$170,578
Finance Director	\$160,316		Open range		\$227,436
Enterprise Applications Administrator	\$114,894	\$120,351	\$126,068	\$132,119	\$138,502
Systems Administrator	\$114,894	\$120,351	\$126,068	\$132,119	\$138,502

BE IT FURTHER RESOLVED that the changes herein shall be effective September 21, 2021.

I, Judi A. Herren, City Clerk of Menlo Park, do hereby certify that the above and foregoing City Council Resolution was duly and regularly passed and adopted at a meeting by said City Council on the twenty-first day of September, 2021, by the following votes:

AYES:

NOES:

ABSENT:

ABSTAIN:

IN WITNESS WHEREOF, I have hereunto set my hand and affixed the Official Seal of said City on this thirteenth day of April, 2021.

\_\_\_\_\_  
Judi A. Herren, City Clerk



## STAFF REPORT

### City Council

Meeting Date:

9/21/2021

Staff Report Number:

21-185-CC

Regular Business:

Direction on drafting an ordinance and ballot measure for City Council consideration on preserving park land

### Recommendation

Provide direction to the city attorney and staff on drafting an ordinance and ballot measure to preserve park land for City Council consideration.

### Policy Issues

The preparation of ordinances and ballot measures are at the discretion of City Council as policy direction.

### Background

Mayor Combs and City Councilmember Mueller are proposing City Council direct the city attorney to prepare an ordinance and ballot measure that would protect park land within the City of Menlo Park from being rezoned for a different purpose.

### Analysis

It is within the City Council's scope of authority to direct the preparation of ordinances as well as add ballot measures to upcoming elections. The city attorney has provided an overview of relevant information as Attachment A. In part, it states the following regarding the process:

"The City Council may submit to the voters, without a petition, a proposition for the repeal, amendment, or enactment of any ordinance, to be voted upon at any succeeding regular or special city election, and if the proposition submitted receives a majority of the votes cast on it at the election, the ordinance shall be repealed, amended or enacted accordingly."

### Impact on City Resources

If City Council directs preparation of an ordinance and ballot measure it will require time from the city attorney's office and of the City Council. Staff estimates placing a measure on the ballot will be approximately \$30,000 to \$45,000. Staff is working with the County to obtain a more precise cost estimate.

### Environmental Review

This action is not a project within the meaning of the California Environmental Quality Act (CEQA) Guidelines §§ 15378 and 15061(b)(3) as it will not result in any direct or indirect physical change in the environment

**Public Notice**

Public notification was achieved by posting the agenda, with the agenda items being listed, at least 72 hours prior to the meeting.

**Attachments**

- A. Procedure for initiatives
- B. Email from City Councilmember Mueller

Report prepared by:  
Starla Jerome-Robinson, City Manager

The provisions of California Constitution Article II, §§ 8 - 11 provide the basis for the powers of initiative and referenda in California. Initiative is “the power of the electors to propose statutes and amendments to the Constitution and to adopt or reject them.” (See Cal. Const. art. II, § 8(a).) “Initiative and referendum powers may be exercised by the electors of each city or county under procedures that the Legislature shall provide.” (Cal. Const. art. II, § 11(a).)

I. INITIAL PROCEDURES FOR INITIATIVES APPLICABLE TO CITIES. The statutory procedures for municipal initiatives are found in Cal. Elec. Code §§ 9200 *et seq.* These sections frequently refer to “ordinances” while, in fact, the initiative power is applicable to all city *legislative* acts regardless of the form. Administrative and adjudicatory acts are not subject to the initiative power.

A. City Council Proposition. The city council may submit to the voters, without a petition, a proposition for the repeal, amendment, or enactment of any ordinance, to be voted upon at any succeeding regular or special city election, and if the proposition submitted receives a majority of the votes cast on it at the election, the ordinance shall be repealed, amended, or enacted accordingly. (Cal. Elec. Code § 9222.)

B. Ballot Title and Summary. The city council may direct the city attorney to prepare an impartial analysis of the measure showing its legal effect and operation. The analysis may not exceed 500 words and must include a statement indicating whether the measure was placed on the ballot by a petition signed by the requisite number of voters or by the city council. (Cal. Elec. Code § 9280.)

C. Ballot Arguments. For measures placed on the ballot by the city council, the city council, or a member or members authorized by the city council, or an individual voter who is eligible to vote on the measure, or bona fide association of citizens, or a combination of voters and associations, may file a written argument for or against any city measure. (Cal. Elec. Code § 9282.)

II. Initiatives Must Be Consistent with the General Plan. Initiatives must be consistent with the county’s general plan, (see *Leshar Communications, Inc. v. City of Walnut Creek* (1990) 52 Cal. 3d 531; *deBottari v. Norco City Council* (1985) 171 Cal. App. 3d 1204 (zoning ordinance referendum petition)).

III. Initiatives Must Comply with the California Environmental Quality Act. Citizen-sponsored ballot initiatives are not subject to the California Environmental Quality Act (“CEQA”). (*Stein v. City of Santa Monica* (1980) 110 Cal. App. 3d 458, 460-61; CEQA Guidelines section 15378(b)(3). This section provides that a “project” under CEQA does not include “[t]he submittal of proposals to a vote of the people . . . .”;.) However, a city proposed ballot measure is subject to CEQA. (*Friends of Sierra Madre v. City of Sierra Madre* (2001) 25 Cal. 4th 165 (2001) (finding that council sponsored measure to exempt 29 properties from register of historic landmarks is subject to CEQA).



---

**Subject:** Park Preservation Ordinance and Measure

**From:** Mueller, Ray

**Sent:** Tuesday, August 31, 2021 8:42 AM

**To:** Combs, Drew <[DCombs@menlopark.org](mailto:DCombs@menlopark.org)>; Jerome-Robinson, Starla L <[SLRobinson@menlopark.org](mailto:SLRobinson@menlopark.org)>; Doherty, Nira F <[NDoherty@bwsllaw.com](mailto:NDoherty@bwsllaw.com)>

**Subject:** Park Preservation Ordinance and Measure

Dear Mayor Combs,

This email is to request at your earliest convenience an item added to the City Council agenda for consideration.

In advance of completing the Housing Element, I would request an item on the City Council agenda, whereing the City Council would consider instructing the City Attorney to draft, and the City Council to adopt a "Park Preservation Ordinance", to be followed by placing a "Park Preservation Measure" on the next General Election Ballot.

The Policy if adopted, and following Measure, if passed, would set forth the City fo Menlo Park may not rezone any area currently zoned as park space for any other use, without the majority vote of the public in a regularly scheduled general election.

As you know, the City of Menlo Park is currently engaged in it 2023 - 2031 Housing element and will be asked to zone for approximately 3000 new housing units. It is foreseeable the vast majority of these new housing units in this Housing Element and in future Housing Elements, will provide little in the way of recreational yards nor active park space for residents to exercise, recreate and enjoy nature. As we learned during the Pandemic, our Park space is so incredibly valuable to the mental and physical health of our community. As our population grows we must cannibilize City park space that will support the public health of present and future generations.

Recently in District 5, I pariticipated in a large community meeting where there was overwhelming support for the City to consider upzoning Sharon Heights Shopping Center to accomodate mized use residential and commercial development, as well as upzoning existing apartment development, as opposed to rezoning land from any public park located in District 5. I believe the overwhelming sentiment to to be the same throughout the City, that our values demand we preseve and where we can expand City parks, at the same time we create housing.

Thank you for your consideration.

With best regards,  
Ray Mueller

With kind regards,  
Ray Mueller

(please excuse odd punctuation. my laptop does not always work well with the City's email system.)

Agenda item L5  
Brian Kissel, resident

Council Members, Friends, and Neighbors,

As you can see by the Change.org petition, there are already nearly 1,500 signatures already in support of Councilman Mueller's Park Preservation Measure: <https://chnng.it/zfdpMPMmsG>

Menlo Park residents understand and support the need for more housing, but there are much better options than taking our precious limited parkland and open spaces, which Councilman Mueller has already recommended.

Per the City Master Plan Update of Oct 15, 2019, there are only 54.2 acres of parkland in Menlo Park relative to a total of ~6,400 acres total, so only 0.8% of our total acreage. Further the master plan discusses "the need for new, expanded or renovated parks, open spaces and facilities; improving and maintaining the existing assets; and acquiring or obtaining access to additional properties for future park and recreation uses."

Menlo Park is a very dense community with 1,883 residents per square mile compared to San Mateo County that has 998 residents per square mile (nearly twice the density). The percent of children under 14 (22%), is higher than the County (15%) or the State (20%). Menlo Park already has a higher percentage of high density multi-family housing (35%) than the county (33%) or the state (31%). With the state mandate for more housing, the density in Menlo Park will only increase. With this increased density, the need for parkland and open space becomes even more important for our community, especially for those living in high density housing with limited yard and open space.

Also from the Menlo Park General Plan:

Nine Guiding Principles formed the basis of the latest update to the City of Menlo Park General Plan. The Guiding Principles describe the kind of place that community members want Menlo Park to be. The goals, policies and programs of the Open Space/Conservation, Noise and Safety Elements, adopted in May 2013, were carefully analyzed to ensure consistency with the Guiding Principles.

One of those principles addresses "Accessible Open Space and Recreation," stating that "Menlo Park provides safe and convenient access to an ample amount of local and regional parks and a range of public open space types." Further to "provide open space lands for a variety of recreation opportunities, make improvements, construct facilities and maintain programs that incorporate sustainable practices that promote healthy living and quality of life."

If anything, we should be finding ways to expand and improve the limited amount of parkland and open space that we have, not taking this precious resource for additional development of any kind. There are much better ways to meet our additional housing needs. Let's explore those options and agree to preserve and protect all our existing parkland. Councilman Mueller has started that discussion, let's support him with the Parkland Preservation Measure and ongoing efforts to identify development opportunities that better serve existing and new members of our community.

Respectfully, Brian Kissel

Agenda item L5  
Denise Dowsett, resident

I find it ironic there is discussion on short-term climate pollutants while another agenda item attempts to remove some precious green space that once gone, will never come back. This park ironically serves a very diverse group of residents. There needs to be a more thoughtful, cleverer way to provide high-density housing without losing precious green space important to everybody's mental and psychological well-being. This should not happen because of the agenda of a few. Any decision should reflect the wishes of all residents.

Agenda item L5  
Bob Dickinson, resident

Contrary to what some are saying, we can preserve our precious green spaces in Menlo Park and build affordable housing too. Building that housing on parkland would be going in exactly the wrong direction as more multi-family housing will actually create a growing demand for parks. We should be emulating our neighbor, Palo Alto, and looking for additional parkland, not cannibalizing what we already have.

And, make no mistake, even a seemingly small encroachment on our existing parks will set us on a slippery slope, creating a precedent that will allow further encroachment in the future in the name of political expediency.

The idea that we need to consider building housing on parkland is underpinned by a misleading narrative asserting that the additional housing needs to be built on land the City owns. In reality, the responsibility of the City is to zone the land needed for it, not to build it. And, the proponents of this view seem to believe that land the city owns is free. Actually, its economic value is its replacement cost and its intangible value to the residents of Menlo Park is priceless.

There are far better places to build new housing than in our parks. For example, in Sharon Heights the shopping center can be rezoned for mixed use and the capacity of the extensive existing multi-family housing can be increased. There are similar opportunities located throughout the city. In addition, we will likely have an oversupply of office space due to the recent shift to more remote and hybrid work and it may be attractive to convert some of that surplus to housing.

Housing should not be looked at in isolation, but rather in conjunction with planning for transit, schools, parks and recreation, and employment opportunities. A key goal of the State of California is higher density housing in proximity to transit, services and jobs in order to reduce long distance commutes by car with their attendant congestion and emissions.

This is a watershed moment in the history of Menlo Park. Let's make sure we don't go down the wrong path by building housing in our parks! Please approve the motion by Mayor Combs and Council Member Mueller.

Agenda item L5  
George John, resident

My wife and I have lived on the peninsula for over 30 years, and we chose Sharon Heights for our retirement home because of the park and open space nearby.

We are counting on you, our city representatives, to represent us and defend our public lands.

It is a strange artifact of our political system that public lands are continuously open to attack by developers, but once the developers win, the space is forever lost to the public.

This asymmetry demands vigilance and thorough consideration before ceding a parcel of land to development and forever removing it from public enjoyment.

As neighbors of the open space next to Sharon Park I can say that every day I see one or more of

- people walking along the paths
- people running along the paths
- people walking their dogs along the paths
- kids playing around the trees
- kids and teachers of a nearby school on a hike /adventure along a path
- people taking photos of themselves against the rustic background
- people taking photos of the hawks that often alight on the trees

There are very few spaces like this on the east side of 280. Surely we can keep them a few more years.

Agenda item L5  
Sanaz Hariri, MD, resident

I grew up in Sharon Heights. My parents still live in that home, and I built a home in Sharon Heights where I am raising twin 8 year old boys. The Duck Pond is the heart of Sharon Heights. I played there as a child, and my boys go there after school with their friends. I run in the park and sometimes read there. The pandemic has shown us how important open spaces are for our mental and physical health. Preserving the Duck Pond for us and our future is essential. I am fully committed to this endeavor as a mother, a citizen, and a doctor.

Agenda item L5  
Jason Hartlove, resident

You can't tell a kid that it's time to exercise; that's a turn-off...you have to say, "Let's go to the park and have some fun! Then you get them to do some running, play on the swings, practice on the balance beam, and basically get a full workout disguised as play. - Gov. Schwarzenegger

The importance of play to childhood development cannot be overstated, as well as the importance of open spaces to general mental well being among the population. City parks serve, day in and day out, as the primary green spaces for the majority of Americans, and with at least 8.6% of Menlo Park housing units being multi-unit apartments, a large portion of our fellow citizens depend on our parks to provide areas for play and relaxation. The Duck Pond, located in Sharon Heights, is no exception and on the weekends, one cannot find parking in the lot due to the popularity of this beautiful space. There are many alternative spaces available for development to meet the long term goals for additional housing unit creation, including rezoning and repurposing existing residential and commercial sites such as the Sharon Heights Shopping Center, the vastly under-utilized commercial office complexes along Sand Hill Road and many others which should be explored before we consider taking away from our citizenry the shared open park spaces we have dedicated to our common use and which we have held dear for so many decades.



Agenda item L5  
Kirill Pertsev, resident

Menlo Park is a tree city with just a few parks, please leave them alone. We have a literal desert right in the downtown (our disgusting parking lots). People who live in "affordable housing" usually have one car per household and sometimes don't have it at all. How one is supposed to commute to work every morning from Sharon Pond? They need Caltrain, buses, access to 101. We have only one store, Safeway, and it takes 15-20 minutes to walk from the Pond to it. A despicable "Limousine liberalism" in its purest form.

Agenda item L5  
Shanda Bahles, resident

I strongly support adding to Menlo Park's housing stock. I also strongly support protecting our existing parkland both for future generations AND for the higher density population new housing will bring. Multifamily housing is necessary to achieve the required new housing mandate. Those families won't have yards. Their children won't have open space to run around in. Except for our parks! Keep our parks. For everyone to enjoy now and for future generations. Upzone existing higher density housing, redevelop Sharon Heights Shopping Center, build on parking lots. There are other options. Thank you.

Agenda item L5  
Tonia Lutch, resident

Please support this measure. It is critical that we keep our green spaces in our city. We have children and a dog and our local park is essential for us and so many families. Honestly, it helps with our mental health as well; my family needs those spaces to go and enjoy and reset. Thank you.

Agenda item L5  
Vicky Tierney, resident

It is imperative that the city of Menlo Park preserve the limited parkland that we already have. While I support the desire to build housing development, this does not mean that we take what little parkland we have in order to meet this need. Such an action is a lose-lose situation. I wholeheartedly support Mr Mueller's measure. Please let's preserve our parkland. Thank you.

Agenda item L5  
Susan Wyle

Please preserve our parks and protect them from housing development! Menlo Park does not have a lot of open green space, and for seniors these parks are very important as they are close to home when we cannot go long distances. During the pandemic, these parks have been and will continue to be very important to the mental health and well being of all. Housing developments on the small park lands that exist will bring traffic, crowding, construction disruption. Sharon Park in particular is home to all kinds of migrating birds and other creatures and would be badly impacted by any loss of acreage or disruption of the natural environment. There are better places to put new housing where park land would not be minimized.

Agenda item L5  
John Ryan, resident

As others have commented, our parks and open spaces are a common and greatly needed resource, particularly for children and for those spending much of the day at home. Public open spaces, once given up to development, are gone forever. The residents of the City understand this and cherish their parks. They should have a say in whether public parks are sacrificed to development when other options have not been exhausted. Trust the citizens to do the right thing, and please support this proposal.

Agenda item L5

Wayne Michelsen, resident

As population and housing density grows on the SF peninsula, we need *\*more\** open park space, *\*not less\**. Residents, both existing and new, need open space for recreation, relaxation, and reflection. This has been evident as our parks have been discovered and visited in record numbers during the covid shut-down. If some park land appears to be underutilized, it is because that space lacks access or amenities, not lack of demand. Instead of reducing the size of any of our Parks, we should be expanding or enhancing the park atmosphere and services they provide.

There has been, and will continue to be, a never ending call to consume open space and develop on every available inch. Once gone, it is gone forever. We are already in a severe open space deficit, and cannot afford to lose any more. We must preserve what little remains.

If opposition to the park preservation proposal is because of housing demand, lets be clear. We all suffer from the associated impacts. But, consuming park space is an unwise option to address it. Additional housing is much better incentivized in other ways. Proposals to rezone commercial areas for multi-use residential-over-commercial and/or higher-density condo/apartment sites seem promising. New and visiting residents will appreciate *\*preserved or expanded\** parks, rather than reduced.

Agenda item L5  
David Greoig, resident

I strongly back this effort for an ordinance and ballot measure to preserve our park land. I hope this is given full consideration and allows the citizens of Menlo Park to decide issues about our parks. Our parks are a big part of what makes Menlo Park Menlo Park. Let's keep them the way they are and look harder for other alternatives.



Agenda item L5  
Patricia Kepler, resident

To the Menlo Park City Council:

As a 60-year resident of Menlo Park, I strongly support the measure introduced by Councilman Ray Mueller to preserve our parks.

Menlo Park is a lovely city, but it does not have an abundance of open space or parkland. One need only look at the new housing constructed along El Camino and elsewhere to know that our future holds more density. It is vital that we take measures to preserve the parks and open spaces that we already have.

There is a great human need for places that are natural and peaceful, where one can get away from the busy world, if only for a short time. There is also a need for places where families can gather to picnic, to let children play and run freely. This is the primary purpose of parks in a community.

Please see that our parks are permanently preserved, not just for those of us here today but for those who will be residents here in the years to come. Too often when things are lost, they can never be regained.

Patricia Kepler

Agenda item L5

Robert Vernstrom, resident

Public park land is very limited in Menlo Park. Available open space will become even more critical as the Council adds additional multi-family housing across the city. Residents of this new housing will need more, not less public park space. Using land zoned for commercial development is a more rational approach than to give away already limited park space that cannot easily be replaced. You can add a story to a commercial building, but not to a public park. Please allow a ballot measure to let the people of Menlo Park advise on this issue. Acting against the popular is surely not your intent.

## Agenda item L5

### Jennifer Johnson, resident

Dear City Council Members,

I am a former Parks & Recreation Commissioner and greatly value our parks and open spaces. I worked diligently for years with the Commission to ensure that our parks are safe, accessible, and inclusive. I would never want to lose any of our park land or open spaces as they are incredibly vital to our health as a community. However, I Do Not support this ordinance or ballot measure for a number of reasons.

First, we have a representative democracy from the Federal down to the City level. We elect people who we believe will serve well and support our values. They study the issues, receive input from multiple sources, and then make decisions. This measure would allow our elected representatives to avoid the responsibility for making these, sometimes very difficult and contentious, decisions. These kinds of ballot measures can also be heavily influenced by those who are able to spend lots of money. These decisions should not be made on the basis of who can outspend the other. And, while I don't want Menlo Park to re-zone parks or open spaces if there other options, there may arise circumstances in which, during an emergency or for a certain time period, that City Council may need to make a quick, difficult decision. In those circumstances, waiting for an election may not be possible.

Second, who will pay for the proposed ballot measure and - if it is successful - subsequent local referendums? It is estimated that it will cost the City \$35,000-40,000 and an unknown, but likely large, amount of staff time. Will all these costs be borne by the tax payers of Menlo Park? Will those with the means to pay for these measures, and the associated polling, advertising and phone banking, gain even more control over their fellow citizen's lives? There is already tremendous inequity in our city.

Finally, I am concerned about the timing and motivations behind this measure. I was a Parks and Recreation Commissioner for 5 years and at no time was it suggested that there was a need for something like this. However, immediately after it was suggested that low-income housing be built in undeveloped park land in Sharon Park, obstacles to rezoning this land became an immediate priority. Apparently, a small number of city residents have had an opportunity to discuss this measure during a community meeting with their council member. Surely voters from the rest of Menlo Park deserve the same opportunity with their council members. Putting something on the ballot deserves at least as much community outreach as putting a bathroom in a local park.

We have elected representatives who are tasked with these decisions. Our remedy if we do not agree is to elect someone else the next time. We also have a legal and moral obligation to ensure that all people in Menlo Park are represented, valued, and heard, no matter where they live.

Thank you for your consideration.

Sincerely,

Dr. Jennifer Johnson

Agenda item L5  
Gordon Wong, resident

Council Members, Friends, and Neighbors,

I have already written in change.org and want to write in more detail here. Please note that there are nearly 1200 signatures on change.org so this is a passionate matter for many people. see <https://chnng.it/zfdpMPMmsG>

While I recognize the need for more housing in Menlo park, destroying limited parks, a nonrenewable resource, to achieve this is an unacceptable solution to me. Councilman Mueller has alternative suggestions for you to consider.

Per the City Master Plan Update of Oct 15, 2019, there are only 54.2 acres of parkland in Menlo Park relative to a total of ~6,400 acres total, so only 0.8% of our total acreage. Further the master plan discusses "the need for new, expanded or renovated parks, open spaces and facilities; improving and maintaining the existing assets; and acquiring or obtaining access to additional properties for future park and recreation uses."

Menlo Park is a very dense community with 1,883 residents per square mile compared to San Mateo County that has 998 residents per square mile (nearly twice the density). The percent of children under 14 (22%), is higher than the County (15%) or the State (20%). Menlo Park already has a higher percentage of high-density multi-family housing (35%) than the county (33%) or the state (31%). With the state mandate for more housing, the density in Menlo Park will only increase. With this increased density, the need for parkland and open space becomes even more important for our community, especially for those living in high density housing with limited yard and open space.

Also, from the Menlo Park General Plan:

I quote from Brian Kissel's letter to you

"Nine Guiding Principles formed the basis of the latest update to the City of Menlo Park General Plan. The Guiding Principles describe the kind of place that community members want Menlo Park to be. The goals, policies and programs of the Open Space/Conservation, Noise and Safety Elements, adopted in May 2013, were carefully analyzed to ensure consistency with the Guiding Principles.

One of those principles' addresses "Accessible Open Space and Recreation," stating that "Menlo Park provides safe and convenient access to an ample amount of local and regional parks and a range of public open space types." Further to "provide open space lands for a variety of recreation opportunities, make improvements, construct facilities and maintain programs that incorporate sustainable practices that promote healthy living and quality of life."

Removal of these parks will destroy the value of Menlo Park as a city compared with other cities. The city's beauty is the reason why people want to be here.

Agenda item L5  
Jennifer Pien, resident

There is already limited park space and destroying that for housing is not the way. Mueller has alt suggestions and they make more sense

While I recognize the need for more housing in Menlo park, destroying limited parks, a nonrenewable resource, to achieve this is an unacceptable solution to me. Councilman Mueller has alternative suggestions for you to consider.

I quote from Kisslers letter

"Per the City Master Plan Update of Oct 15, 2019, there are only 54.2 acres of parkland in Menlo Park relative to a total of ~6,400 acres total, so only 0.8% of our total acreage. Further the master plan discusses "the need for new, expanded or renovated parks, open spaces and facilities; improving and maintaining the existing assets; and acquiring or obtaining access to additional properties for future park and recreation uses."

Menlo Park is a very dense community with 1,883 residents per square mile compared to San Mateo County that has 998 residents per square mile (nearly twice the density). The percent of children under 14 (22%), is higher than the County (15%) or the State (20%). Menlo Park already has a higher percentage of high density multi-family housing (35%) than the county (33%) or the state (31%). With the state mandate for more housing, the density in Menlo Park will only increase. With this increased density, the need for parkland and open space becomes even more important for our community, especially for those living in high density housing with limited yard and open space."

Agenda item L5

Todd Maibach, resident

Every night when I take my evening walk, I walk past Sharon Park and the open space park on Valparaiso Hill. They are beautiful spaces where people can go to enjoy the natural world and see hawks, egrets, herons and other wild life. I strongly support the measure to preserve our local parks. If we allow them to be subdivided for building new apartments, there is no going back. Thirty years from now, the next generation could be living in ever more crowded conditions, in small apartments and condominiums, with no backyards and also no parks. Please preserve the existing parks. New housing can be built elsewhere, close to the 101 freeway and close to the offices of Facebook.

## Agenda item L5 Shirley Wang, resident

Council Members, Friends, and Neighbors,

I have already written in change.org and want to write in more detail here. Please note that there are nearly 1200 signatures on change.org so this is a passionate matter for many people. see <https://chnng.it/zfdpMPMmsG>

While I recognize the need for more housing in Menlo park, destroying limited parks, a nonrenewable resource, to achieve this is an unacceptable solution to me. Councilman Mueller has alternative suggestions for you to consider.

Per the City Master Plan Update of Oct 15, 2019, there are only 54.2 acres of parkland in Menlo Park relative to a total of ~6,400 acres total, so only 0.8% of our total acreage. Further the master plan discusses "the need for new, expanded or renovated parks, open spaces and facilities; improving and maintaining the existing assets; and acquiring or obtaining access to additional properties for future park and recreation uses."

Menlo Park is a very dense community with 1,883 residents per square mile compared to San Mateo County that has 998 residents per square mile (nearly twice the density). The percent of children under 14 (22%), is higher than the County (15%) or the State (20%). Menlo Park already has a higher percentage of high-density multi-family housing (35%) than the county (33%) or the state (31%). With the state mandate for more housing, the density in Menlo Park will only increase. With this increased density, the need for parkland and open space becomes even more important for our community, especially for those living in high density housing with limited yard and open space.

Also, from the Menlo Park General Plan:

I quote from Brian Kissel's letter to you

"Nine Guiding Principles formed the basis of the latest update to the City of Menlo Park General Plan. The Guiding Principles describe the kind of place that community members want Menlo Park to be. The goals, policies and programs of the Open Space/Conservation, Noise and Safety Elements, adopted in May 2013, were carefully analyzed to ensure consistency with the Guiding Principles.

One of those principles' addresses "Accessible Open Space and Recreation," stating that "Menlo Park provides safe and convenient access to an ample amount of local and regional parks and a range of public open space types." Further to "provide open space lands for a variety of recreation opportunities, make improvements, construct facilities and maintain programs that incorporate sustainable practices that promote healthy living and quality of life."

Removal of these parks will destroy the value of Menlo Park as a city compared with other cities. The city's beauty is the reason why people want to be here.

Agenda item L5  
Josie Wong, resident

My name is Josie and I am 12. There are not really good parks to play in the local area that is safe distance for me to walk to and I grew up enjoying the ducks and fish and my memories are there. I don't like other cities bc Sharon Park is so beautiful but I do know that Palo Alto has more parks per resident than we do in Menlo Park so they cannot take away the parks to build more houses. Dad says Councilman Mueller has other solutions and we must do that instead.



Agenda item L5  
Eleanor Wong, resident

My name is Ellie and I am in 6th grade I walk my dog Maggie in the park most days. My sister and I are writing a joint letter. There are not really good parks to play in the local area that is a safe distance for me to walk to and I grew up enjoying the ducks and fish and my memories are there. I don't like other cities because Sharon Park is so beautiful but I do know that Palo Alto has more parks per resident than we do in Menlo Park so they cannot take away the parks to build more houses. Dad says Councilman Mueller has other solutions and we must do that instead.

Agenda item L5  
Marnie Foody, resident

Council Members, Friends, and Neighbors,

Menlo Park residents understand and support the need for more housing, but there are much better options than taking our precious limited parkland and open spaces, which Councilman Mueller has already recommended. I support Ray Mueller's proposal.

Our parks are precious and help us build community. If these are developed, we will never be able to get these precious resources back. Housing development should take in places near public transportation lines, near downtown resources, and where infrastructure is already present suggest as water, sewer, electrical.

If anything, we should be finding ways to expand and improve the limited amount of parkland and open space that we have, not taking this precious resource for additional development of any kind. There are much better ways to meet our additional housing needs. Let's explore those options and agree to preserve and protect all our existing parkland. Councilman Mueller has started that discussion, let's support him with the Parkland Preservation Measure and ongoing efforts to identify development opportunities that better serve existing and new members of our community.

Agenda item L5  
Diana Hewitt, resident

I support Councilman Ray Mueller's Park Preservation Measure. Please preserve our open space! I walk through and enjoy this space 3-4 times per week with my dog (on-leash), and find it very good for the soul. I would hate to lose it.

Agenda item L5

Nikhil Viswanathan, resident

Building housing in Sharon Park is not a good use of our limited green space left in Menlo Park. There are huge parking lots which should be redeveloped instead.

Agenda item L5  
Tracie Nelson, resident

Please do not allow any housing to be built in Sharon Park or any of our city parks. We have very little park space and need to protect this land ESPECIALLY as our housing areas become more dense and residents need outdoor spaces to visit. So many people in our community use this space to unwind, gather with family and friends, and to recreate. If we've learned anything from the last year and a half of the pandemic, we have learned how valuable these open spaces are to our well-being.

Agenda item L5  
Linda Lee, resident

**PLEASE PRESERVE OUR PARKS IN MENLO PARK!!!**

We need them for our mental health and well being for adults just as much as for our children. We all need park spaces to enjoy being outdoors and to breath fresh air now more than ever as COVID pandemic continue to persist and is most infectious inside enclosed spaces. Everyone needs park spaces for so many reasons.

**WE MUST PRESERVE OUR PARKS.**

Agenda item L5  
Sadler Nelson, resident

Today I visited a neighboring peninsula city for my daughter's soccer game and was impressed with how much park land it had compared to Menlo Park. That is not to say I am not impressed with the parks of Menlo Park - it is just to say, we can't afford to lose any. I would take this same daughter around when she was younger to explore each park of Menlo Park on a Saturday morning (our own "Tour de Menlo") and it was great family time. We need to preserve these precious jewels of our community. Please preserve what we have. Please preserve Sharon Park - all of it, including the ramble of nature that exists. Please take action for us as residents today but also our children in the future.

Agenda item L5  
Doug Lee, resident

PLEASE PRESERVE OUR PARKS IN MENLO PARK.

We need them for our mental health and well being for adults just as much as for our children. We all need park spaces to enjoy being outdoors and to breath fresh air now more than ever as COVID pandemic continue to persist and is most infectious inside enclosed spaces. Everyone needs park spaces for mental health, well being, mind, soul and body, and so much more.

WE MUST PASS A MENLO PARK LAW TO PRESERVE OUR PARKS. OUR LIVES DEPEND ON IT.



Agenda item L5  
Naomi Lee, resident

PLEASE PRESERVE OUR PARKS IN MENLO PARK.

We need them for our mental health and well being for adults just as much as for our children. We all need park spaces to enjoy being outdoors and to breath fresh air now more than ever as COVID pandemic continue to persist and is most infectious inside enclosed spaces. Everyone needs park spaces for mental health, well being, mind, soul and body, and so much more.

WE MUST PASS A MENLO PARK LAW TO PRESERVE OUR PARKS. OUR LIVES DEPEND ON IT.

Agenda item L5  
Jackson Lee, resident

PLEASE PRESERVE OUR PARKS IN MENLO PARK.

We need them for our mental health and well being for adults just as much as for our children. We all need park spaces to enjoy being outdoors and to breath fresh air now more than ever as COVID pandemic continue to persist and is most infectious inside enclosed spaces. Everyone needs park spaces for mental health, well being, mind, soul and body, and so much more.

WE MUST PASS A MENLO PARK LAW TO PRESERVE OUR PARKS. OUR LIVES DEPEND ON IT.

Agenda item L5  
Edie Goldberg, resident

The last 1.5 years have been hard on many. Many residents were confined to their homes or apartments for long periods of time. Our parks, across the city, have never been so well used. As a psychologist, I can attest to the importance of parks and open spaces to provide a mental health boost to not only our city residents, but from others in both San Mateo and Santa Clara County. As we look to expand the density of housing in Menlo Park, we would be short sighted to consider using park land as a potential opportunity for a new housing location. We need more parks, not fewer.

The name of our town is Menlo PARK... we should be doing everything in our power to preserve and enhance our existing park land. I support Councilman Mueller's Park Preservation Ordinance and I think all the citizens in Menlo Park should have a say in this matter.

Agenda item L5  
Linda Mikula, resident

I am writing today to voice support for Councilman Ray Mueller's Park Preservation Measure. Our very fine, family-friendly city's Master Plan discusses the importance of protecting and investing in our parkland and open spaces. Currently, our parkland represents less than 1 percent of Menlo Park's 6,400 acres.

Please let's work together to keep the parks in Menlo Park!

Sincerely,  
Linda Mikula  
Homeowner and 23-year Menlo Park Resident

Agenda item L5  
Lizzie Bradley, resident

I am a Menlo Park resident and believe that its in our best collective interest to preserve our parks. I do understand and agree that we continue to need to provide additional housing for more people in ALL Menlo Park districts. This will undoubtedly be achieved through more housing density and less personal outdoor space (i.e yards). For this reason, it will become be even more important to ensure that park lands are protected and available - so that there is enough park space for the growth in our population.

Creating a preservation status for parks in Menlo Park is a great way to ensure that parks do not get reduced inadvertently by the City Counsel. I do not believe that council members should be able to decide to build on or reduce land designated as park space without a vote of the people of Menlo Park. This is such an important topic that it needs to be determined by a vote.

Agenda item L5  
Kimberly Birn, resident

Council Members,

Our parks are one of our city's greatest assets. They provide a place for peace, exercise, community, and connection with nature. As our population and housing grows, we will require all that our parks offer us even more and simply cannot afford to lose a foot of park space to development. Everyday, I walk my dog around Sharon Park, my 90 year old mother comes to walk and sit at the park, my children have grown up enjoying it's playground, pond, trails, grassy fields and idyllic views of the hills, trees and fog rolling in. It is not only an escape for Menlo Park residents, including those who live in the numerous Sharon Heights apartment complexes and other MP complexes, but for the many visitors from other communities and towns who come daily to enjoy it. Our other parks are equally precious, from Burgess to Nealon to Jack Lyle to Kelly to Flood, they offer a respite that all of us crave and need, as close to our homes as possible to meet the needs of the young and the old, and to build local community as well.

There are other developed places to build the additional housing we need, if we consider building up existing apartment complexes and office/business structures to including housing above them (ie. the apartments on Sharon Park Drive near Sand Hill Road, the Sharon Heights Shopping Center, downtown parking lots and above businesses, ECR). Please consider supporting Councilman Mueller's Park Preservation Measure so that the great good can be served, with preserved park space for our growing population and wise use of expanded building in developed but underutilized locations with ready access to public transportation.

Thank you for preserving our parks and our communities so that Menlo Park continues to be a place we all treasure.

Sincerely,  
Kimberly Birn

Agenda item L5  
MaryAnn Saunders

I would like Ray Mueller's resolution about not using city parks for housing approved.

Agenda item L5  
Joan DeVenne

I love coming to Sharon Park for a daily walk to enjoy the beauty of the surrounding hills, the peace of the park, and the feeling of being lost in nature. There are very few places in Menlo Park, Palo Alto or Redwood City where you can do this. I live in an apartment complex and enjoy the escape to this park. So as someone who has lived ninety years and seen so many changes, I just want to ask you to please protect our wonderful parks! We have so few of them and we need them now and for future generations.



Agenda item L5  
Jerry Birn, resident

Dear Council Members,

With parklands representing less than 1% of our Menlo Park acreage (per the City Master Plan, Oct 2019), we cannot afford to give up land at our parks for development. Our city has higher multi-family density housing than the county or the state, and continued plans and needs for building more housing will increase this. For that reason, park space will be even more important for our expanding population. Please help us to preserve our parks which benefits all our residents by supporting Councilman Ray Mueller's measure to protect our parks. He has proposed viable locations for further housing development which will meet our growing housing needs while still preserving our irreplaceable parks.

Sincerely,  
Jerry Birn

Agenda item L5  
Mark Reinstra, resident

Throughout our history, we have seen the erosion of public spaces and community gathering places. This is an opportunity to make sure that Menlo Park retains the things that make it special. Kids playing and exploring is a critical need for their development and we need to be guardians of future generations. If we don't protect the parklands, our children and our children's children will have no place to socialize. Please think of the best for our community over the next decades. Let's increase density where we already have it and allow our open spaces to continue to be an oasis of calm and play.

Agenda item L5

Susan Reinstra, resident

Sharon Heights is surrounded by busy streets, and Sharon Park, including the eucalyptus grove, is the only park or open space available to the many children in Sharon Heights without crossing a busy street. It is critical to preserve open space for children in our neighborhood.

Agenda item L5  
Brennan Birn, resident

Having grown up in Menlo Park, I have been lucky enough to enjoy our parks, from the playgrounds to the sports fields, and I have loved riding bikes, walking trails, and enjoying picnics, views and grassy fields there. Our parks are one of the best things about Menlo Park. Yes, they put the "park" in our town's name. As a college student, someday I hope to return to here afterwards. So yes, I am interested in affordable housing. However, I would never want it at the expense of our parks. Please, let's preserve our parks, support Councilman Ray Mueller's measure, and come up with other locations to build affordable housing, including at existing developed sites that can be rebuilt and expanded to meet these needs.

Thank you,  
Brennan Birn

Agenda item L5  
Alex Liston, resident

Access to parkland and open space is an essential aspect of living in Menlo Park. It should be the Council's goal to improve, protect, and expand our residents' experiences with nature rather than to destroy them.

Agenda item L5  
Thomas Smith, resident

I'm writing because I'm incredibly concerned that Sharon Park and Burgess Park have been mentioned as possible building sites for affordable housing.

My family lives in Sharon Heights and uses both Sharon Park and Burgess Park on a weekly basis and absolutely loves these two parks. Sharon Park is the only park with a flat open space within walking distance of our home and so to lose that open area to housing would be devastating for our family. Additionally, we regularly use Burgess Park for many other outdoor activities and so losing that park to housing would also be a great loss to our family.

Please preserve all parkland in our city. Our family and our neighbors need open space and play/exercise areas that are open to all members of the community. We should be finding ways to expand the very limited amount of parkland in Menlo Park and, in particular, Sharon Heights, not taking away parkland. Re-zoning the Sharon Heights Shopping Center to allow low-income and affordable housing, retail and services is a much better option for all and one that I would support.

Agenda item L5  
Jeffrey Fenton, resident

To the City Council: I strongly support Councilmember Mueller's proposed ordinance to preserve City park land. Parks are critical to mental and physical health. As Menlo Park's population increases, the need for parks and recreation increases as well. Parks also help mitigate the "heat island" effect from climate change. There are other more workable solutions to address housing needs at suitable sites throughout the City while preserving our parks as an endowment for current and future generations. I urge you to adopt this proposed ordinance. Thank you, Jeffrey Fenton, Menlo Park resident.

Agenda item L5  
Anonymous, resident

It has been brought to my attention that Sharon Park and Burgess Park have been suggested as locations to build affordable housing. I believe in and strongly support affordable housing (in the true sense of the words).

However I also know that parks and green spaces are extremely important, for the health of our environment, and our physical and mental health. We all benefit from these areas of space to live, play and breathe in. Please preserve the open spaces and parks in our area for us now and for future generations.

There are many unused or underused buildings, stores and parking lots in our area. Please develop plans to use some of those for housing instead.



Agenda item L5

Laura Garcia-Manrique, resident

Menlo Park must provide for additional housing and must protect existing parkland. These are not conflicting goals. In fact protecting existing parkland is even more critical when population becomes denser. Once our parks are gone, they are gone forever. I am in support of Ray's proposal to rezone existing areas to allow for more units to be built and to protect existing parkland from further development.

Agenda item L5  
Jacqueline Wender, resident

Dear Councilmembers:

I strongly support Councilmember Ray Mueller's proposed ordinance to preserve park land in Menlo Park.

I understand the City's requirements in the Housing Element, including the requirements around diversifying housing locations as well as affordability. But the City should not meet this requirement by removing, in all likelihood permanently, the precious parks and open spaces that are such a critical piece of everyone's quality of life. Indeed, with increasing city density I would argue that the City has an obligation to increase the availability of land for passive and active recreation.

In Mr. Mueller's email accompanying the Council agenda, he refers to the possible upzoning of the Sharon Heights Shopping Center to a mixed-use development of housing – including affordable, low-income housing – retail, and services. I would strongly support that rezoning and that new development.

Please do not succumb to the false notion that NIMBYism is at play in the pleas to preserve our parks, including Sharon Park. It is not. Rather, we urge you to heed the voices of the residents and find ways to meet the housing demand AND preserve the parks and open spaces that are so vital to all members of our community.

As Joni Mitchell so aptly put it: "Don't it always seem to go, that you don't know what you've got 'til it's gone. They paved paradise, and put up a parking lot."

Thank you for your consideration.

Respectfully,  
Jacqueline Wender

Agenda item L5  
Nicole Ramirez

Keep your hands off of our parks!!! I am vehemently opposed to this measure. As a long time resident of Menlo Park (40+ years), I have seen this area change and local gems disappear in place of apartment buildings, only adding to the congestion in areas such as downtown Menlo Park. Sharon Park is a much needed green space in Sharon Heights as there are many apartments nearby that need an open space for families to relax and enjoy. Developing the land at that park (and other parks in the city for that matter) would be an absolute travesty. Please pass Ray Mueller's measure as the community stands behind him. He is the only one with a sound mind not in it for the money.

Agenda item L5

Anonymous

Please keep the parks for the use by children and elderly.

Agenda item L5  
Dan Myers, resident

Parks are an invaluable asset that should exist in perpetuity.

They are not land banks to be drawn on when we decide they are necessary for de novo development.

Re-development is a logical solution.

Look no further than what people are doing to the private housing stock in Menlo Park.

Hundreds of homes have been renewed through rebuilding and/or adding to existing structures.

The city should do the same.

Agenda item L5

Lynette Viswanathan, resident

MP residents strongly support additional housing in the neighborhood but taking our very limited parkland and open space is not the best approach. The open space that Karen refers to should be developed as part of the park plans for future generations of not only the existing residents but addtl housing that is being proposed. Sharon Park is currently being used by residents across MP and their families. There are photo shoots, open air classes, pre school nature hikes, weddings and seniors walking all day. Leave the parks alone and find other sustainable areas close to transportation, groceries and shopping. The last thing we need is more cars, additional buses and increased density. It one of the rare open spots that allows you to breathe fresh air, enjoy nature and hear the birds at their best. Develop shopping areas like the Safeway parking lot that is closer to the freeway and easier to build around. Allow development of more vertical spaces around the apartment complexes. Our downtown is an eyesore, dealing with SB 9 and 10 is anybody's guess and now we are dealing with losing part of the only park we have. Please consider supporting Councilman Ray because it is the right thing to do for all our current and future residents.

Agenda item L5  
John Carter, resident

We need to keep the Parks in Menlo Park.

For a city that has so much pride in its trees, why would we want to remove trees and parkland only to replace that precious resource with housing. I clearly support more low and middle income housing, but it is a false choice to choose between housing and parks.

We should look more carefully into better sites than parks & concentrate housing near transportation hubs (Caltrans).

Agenda item L5

Sridhar Viswanathan, resident

I believe Menlo Park residents understand and are supportive of having more housing, what they are appropriately objecting to is the conversion of our precious limited parkland and open spaces as the solution proposed by some for additional housing.

As we increase housing in MP and become denser as a community it becomes even more important to maintain the existing parks and limited open spaces we have for a growing community, and preferably find ways to further expand availability of parks and open spaces. Substantial housing can be added without the conversion of our parks and associated open spaces as outlined below.

My rationale for choice of spaces to add housing is underscored by easy access to transportation and proximity to stores/shopping. This maximizes convenience for work and personal activities and minimizes the likelihood the worsening the traffic situation. The conversion of as many parking spaces in downtown MP as possible with multistory buildings with parking on bottom 2 levels has the potential to contribute meaningfully to our objectives of increasing housing (and has been proposed by several MP residents). Other potential spaces that allow for additional substantial housing (using the concept above) could include the Sharon Heights shopping center.



Agenda item L5  
James McCann, resident

While housing is important, parks are central to our neighborhoods and to our identity. Housing opportunities have been identified at better locations more central to transit and services and those opportunities will continue to present themselves in urban redevelopment. Our already limited parks should be preserved for the majority of voters and residents who use them and chose to purchase their homes near them.

Agenda item L5

Daniel Stallsmith, resident

Hi there. My family and I live a few blocks from Sharon Park and it is such a respite and harbor of tranquility amongst a very crowded Menlo Park. We were saddened to hear that the Park might be removed. We hope that there is some way to better utilize existing commercial areas like Sharon Park Plaza for additional building, rather than removing one of the few open/natural spaces in Menlo Park.

Agenda item L5  
Diane Brandt, resident

Menlo Park City Council Members,

I urge the city council to adopt Council member Ray Mueller's proposed Park Preservation Ordinance and place a measure on the ballot that would require a vote of Menlo Park residents to re-zone park land.

I support alternate sites for housing, such as redevelopment of Sharon Heights Shopping Center to a mixed-use site that could include low-income and affordable housing.

Our green space is already in high demand and will become more so as additional housing units are added in the coming years. We need trees to clear our air from smoke and we need open space for our physical and mental well-being.

Please support the public health of current and future generations of Menlo Park residents.

Agenda item L5  
Priya Bhusri, resident

Dear City Council members,  
I have lived in Menlo Park for over 20 years--first in the Willows, then Sharon Heights and now as a home owner in Central West Menlo. What drew me here over 20 years ago was the open green space, great schools and wonderful community. Please preserve our parks. We all recognize the need to create public housing in our city but I think many of us agree that taking land from our precious open green space is not the answer. There are plenty of other areas that can be developed that will satisfy both our current Menlo Park residents and that will make better sense for our future fellow residents who will inhabit our great city.  
Thank you for your service to our community.  
Respectfully submitted,

Agenda item L5  
Tim Johnston, resident

Commenting as President of the Menlo Park Historical Association, we applaud Mayor Combs and City Council-member Mueller for their efforts to preserve the parks of Menlo Park. We view the parks as an integral part of the fabric of the city's rich history and legacy.

But we encourage the council to equally commit time and energy (and a sense of urgency) to the creation of a Historic Preservation ordinance that protects and preserves what remains of this town's historic landmarks and buildings - a topic that has been presented for consideration, either formally or informally, many times over the years and has yet to gain any traction.

Thank you.

# Parks Preservation Ordinance and Ballot Measure Proposal



*Presented By:  
Council Member Ray Mueller*

Menlo Park City Council Meeting

September 21, 2021

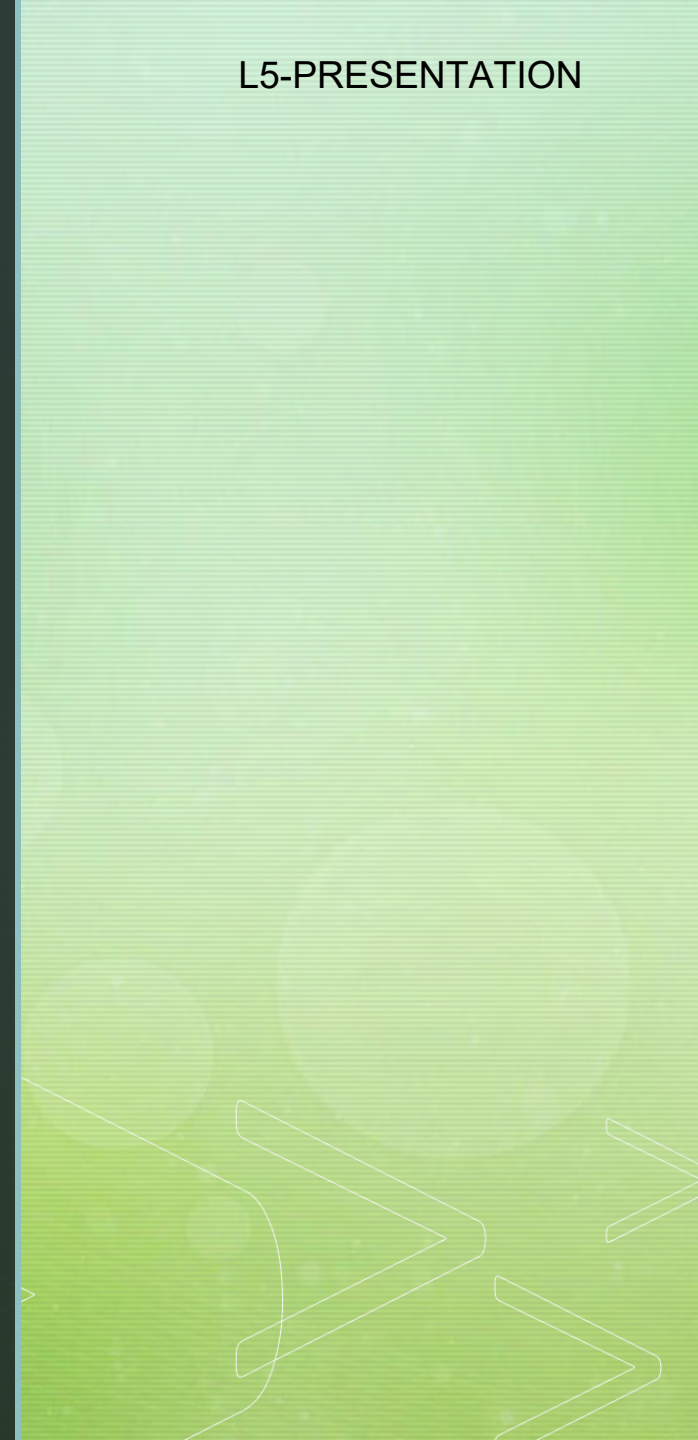

September 10, 2012

MEMORANDUM

TO: Housing Element Steering Committee  
FROM: City Attorney  
RE: Converting Parkland to Affordable Housing

California Government Code sections 38440 through 38462 set forth the procedure by which a city may dispose of land owned by the city in fee and dedicated by the city as parkland. [By designating land as parkland in a city's general plan and on various city maps and by operating the land as a park for an extended number of years, land would be considered "dedicated" by the city as parkland, and subject to the provisions of sections 38440-38462.] Except for an exchange of land for a minor portion of a park that effectively results in no loss of parkland, generally a city may only dispose of dedicated parkland by going through a public hearing process regarding the closure and abandonment of the park and by holding a special election to determine whether or not to sell or dispose of the parkland. Sections 38443 through 38450 outline the specific requirements and procedures for the notice, public hearing, and vote required by section 38441 to dispose of dedicated parkland.

There is a second procedure that would allow the City to use land dedicated as parkland for "other municipal purposes." (Cal. Govt. Code § 37111.1.) Unless the affordable housing was developed by the city, it does not appear that affordable housing is a "municipal purpose" as contemplated in this section. Under the terms of this section, in order to convert dedicated parkland to a different municipal purpose, the city must have acquired an equal or greater amount of land in the last three years that has been dedicated and developed as parkland, and the proposed use of the parkland to be converted must comply with the city's general plan.

9/12/12  
City Attorney Opinion  
California State Law

- At the Housing Commission meeting August 4, 2021, comments from Chair Grove identified Sharon Park for consideration for development in our current Housing Element. In that meeting she called on City Council and Planning Commission to consider this proposal.
- Sharon Heights Homeowners Association Meeting, August 30th. At that meeting the prior City Attorney opinion was raised. Concern was expressed the City may pursue using one of the exceptions in the Government Code to move forward with developing within City parks.
- Residents shared their concern that Sharon Heights has many residents living various types of multi-family housing who use Sharon Park, and the need will only increase as density continues to increase. The park is 3 miles from Burgess Park.





- The concern that parks may be threatened by the same Govt. Code exceptions was expressed for every park in the City.
- At the meeting I asked residents to allow me to first take this issue to the City Council before the residents pursued a ballot measure on their own.
- In response to Chair Grove's call for consideration, and in light of resident feedback, on August 31st, I emailed the Mayor, requesting this issue be agendized. The intent before you tonight is to close the exceptions in the Government Code, and to always require a public vote, without exception, when proposing the conversion of parkland for a non Park and Recreation use in the City of Menlo Park.



- Instruct the City Attorney to draft a Parks Preservation Ordinance for consideration:
  - a. identifying all “dedicated parks” in Menlo Park
  - b. requiring a majority vote of public should the City seek to use parkland for “other municipal purposes” not related to park and recreation uses, under Cal. Govt. Code § 37111.1.
  - c. requiring a majority vote of the public should the city seek to convey a minor portion of parkland in exchange for parkland located contiguous to the current park, pursuant to Cal. Govt. Code § 38411



- Instruct the City Attorney to draft an accompanying Parks Preservation Ballot Measure for consideration to be put on the next San Mateo County election ballot:
  - a. the Park Preservation Ballot Measure would include all of the elements requiring a majority public vote included in the Park Preservation Ordinance.
  - ▾
    - a. If adopted, the Park Preservation Ballot Measure would preclude this City Council, and future City Councils rescinding the ordinance at a later date. Rather a vote of the public would be required to rescind the park protections set forth in the measure.



- Since emailing the Mayor, over the last two weeks, concerned residents have gathered close to 1700 signatures from residents all over Menlo Park and in neighboring communities on a Change.org petition. Residents have also canvassed neighborhoods and worked the farmers market. The overwhelming response of the community has been that we must not develop in City parks. Additionally the nonprofit group Green Foothills sent a letter supporting that development not occur in our City parks.
- Still, just four days ago on September 17th, Chair Grove was published in an Almanac editorial again advocating that Sharon Park be considered for housing in the City's Housing Element.



- In a positive development for residents advocating against developing in City parks, today Chair Grove emailed this Council that she has now dropped the issue of pursuing housing in City parks. Emails received from Greenbelt Alliance that Ms. Grove was cc-ed on and also from the non-profit advocacy group Menlo Together have indicated that as development in parks is now a non-issue, the City should not spend time passing an ordinance nor pursuing a ballot measure. Chair. Grove states now, “Our parks our protected.”
- Respectfully, the residents who I have worked with on this issue, as well as I, believe our City parks are not adequately protected as any other party could still seek to exercise the Govt Code exceptions in the future, without a vote of the public.



- We are requesting the City Council instruct the City Attorney to draft for consideration at a future meeting, a Parks Preservation Ordinance:
  - a. identifying all “dedicated parks” in Menlo Park
  - b. requiring a majority vote of public should the city seek to use parkland for “other municipal purposes” not related to park and recreation uses, under Cal. Govt. Code § 37111.1.
  - c. requiring a majority vote of the public should the city seek to convey a minor portion of parkland in exchange for parkland located contiguous to the current park, pursuant to Cal. Govt. Code § 38411



- Instruct the City Attorney to draft for consideration at a future meeting, an accompanying Parks Preservation Ballot Measure to be put on the next San Mateo County election ballot:
  - a. the Parks Preservation Ballot Measure would include all of the elements requiring a majority public vote included in the Park Preservation Ordinance.
  - ▾
    - a. If adopted, the Parks Preservation Ballot Measure would preclude this City Council, and future City Councils rescinding the ordinance at a later date. Rather a vote of the public would be required to rescind the park protections set forth in the measure.
- Thank you for your consideration





**STAFF REPORT**

**City Council**

**Meeting Date:** 9/21/2021  
**Staff Report Number:** 21-178-CC

**Informational Item:** City Council agenda topics: October 2021

**Recommendation**

The purpose of this informational item is to provide the City Council and members of the public access to the anticipated agenda items that will be presented to the City Council. The mayor and city manager set the City Council agenda so there is no action required of the City Council as a result of this informational item.

**Policy Issues**

In accordance with the City Council procedures manual, the mayor and city manager set the agenda for City Council meetings.

**Analysis**

In an effort to provide greater access to the City Council's future agenda items, staff has compiled a listing of anticipated agenda items, Attachment A, through October 26, 2021. The topics are arranged by department to help identify the work group most impacted by the agenda item.

Specific dates are not provided in the attachment due to a number of factors that influence the City Council agenda preparation process. In their agenda management, the mayor and city manager strive to compile an agenda that is most responsive to the City Council's adopted priorities and work plan while also balancing the business needs of the organization. Certain agenda items, such as appeals or State mandated reporting, must be scheduled by a certain date to ensure compliance. In addition, the meeting agendas are managed to allow the greatest opportunity for public input while also allowing the meeting to conclude around 11 p.m. Every effort is made to avoid scheduling two matters that may be contentious to allow the City Council sufficient time to fully discuss the matter before the City Council.

**Public Notice**

Public notification was achieved by posting the agenda, with the agenda items being listed, at least 72 hours prior to the meeting.

**Attachments**

A. City Council agenda topics: October 2021

Report prepared by:  
Judi A. Herren, City Clerk



**Tentative City Council Agenda**

#	Title	Department	Item type	City Council action
1	Financial advisory services and bond counsel services for a Measure T bond issuance	ASD	Regular	Contract award or amend
2	Ratify successor MOU - POA	ASD	Regular	Adopt resolution
3	Appeal provision revision-Ordinance first reading	CA	Regular	Approve
4	491 Middle Ct - Subdivision Ordinance Variance	CDD	Public Hearing	Approve
5	BMR fund recommendation - MidPen Pierce Rd. housing	CDD	Regular	Adopt resolution
6	Housing Element - Preferred Land Use Strategy	CDD	Regular	Approve
7	Samaritan House agreement amendment (ARPA \$)	CDD	Consent	Approve
8	2021 priorities and work plan quarterly report as of September 30	CMO	Consent	Receive and file
9	Adopt Community Amenity Implementing Regulations and Updated Amenities List	CMO	Regular	Adopt resolution
10	Approve EQC annual work plan	CMO	Consent	Approve
11	CAP #1 - existing building electrification strategy recommendation study session	CMO	Study Session	Direction to staff
12	Climate Action Plan Progress, GHG inventory update, and proposed amendments	CMO	Regular	Direction to staff
13	SBWMA ordinance in the SB1383, first reading	CMO	Regular	Adopt ordinance
14	TEFRA Hearing - Silicon Valley International School	CMO	Public Hearing	Adopt resolution
15	Library Commission work plan	LCS	Consent	No action
16	Parks and Recreation Commission work plan	LCS	Consent	No action
17	Response: Grand Jury report-Building trust between Community and Law Enforcement via the Racial and Identity Profiling Act	PD	Consent	Approve
18	Adopt Resolution removing the left-turn restriction at 105/125 Constitution Drive	PW	Consent	Adopt resolution
19	Adopt Resolution to support the City's shuttle program and submit an application for the Caltrans sustainable planning grant	PW	Consent	Adopt resolution
20	Approval of the 2021-2022 vehicle purchase	PW	Consent	Contract award or amend
21	Automated water meter reading project agreement	PW	Consent	Contract award or amend
22	Complete Streets Commission work plan approval and adopt a resolution to support Seamless Transit Principles	PW	Regular	Approve
23	FEMA BRIC grant study session	PW	Study Session	Direction to staff
24	Left-Turn Restriction on Garwood at Oak Grove	PW	Regular	Approve
25	SFPUC Water Service Agreement Amendment	PW	Consent	Contract award or amend
26	Prioritize issuance of Measure T bonds	PW, ASD	Consent	Approve



## STAFF REPORT

### City Council

**Meeting Date:** 9/21/2021  
**Staff Report Number:** 21-180-CC

**Informational Item:** 2021 priorities and work plan quarterly report as of July 31

### Recommendation

The purpose of this informational item is to provide the City Council and members of the public access to the anticipated agenda items that will be presented to the City Council.

### Policy Issues

City Council adopts annual priorities to prioritize limited resources.

### Analysis

City Council adopted its 2021 priorities and work plan at the April 20 meeting. This report transmits an update as of July 31 and contains the best information available, reflecting extraordinary demands on executive and management resources due to work on City Council priorities, maintenance of regular operations, emergencies and unexpected demands on resources, and staff attrition.

### Project types

- City Council priorities. Designation of a project as a priority clarifies that staff may strategically realign limited resources to achieve the stated milestones for priority projects. The realignment may delay work on other projects or impact services to the public.
- City Council work plan. Work plan projects reflect City Council goals. The distinction between a “priority” and a “work plan” project is that resources may be shifted away from work plan projects and public services, if necessary, to make progress on priority projects. shifted away from work plan projects and public services, if necessary, to make progress on priority projects.

The next scheduled update is for work through September 30.

### Public Notice

Public notification was achieved by posting the agenda, with the agenda items being listed, at least 72 hours prior to the meeting.

### Attachments

- A. City Council adopted 2021 priorities and work plan progress report as of July 31

Report prepared by:  
Nick Pegueros, Assistant City Manager

Agenda item M2  
Maria Amundson, resident

Dear Menlo Park City Council and Staff,

On behalf of the many neighbors and neighborhoods in support of a visionary and historic citywide, four-crossing rail Quiet Zone, I want to express our collective delight that the exploration of this is among the city priorities for Menlo Park this year.

We are also deeply grateful that the city's plan is to share a draft RFP with the Rail Subcommittee for public comment before it is made final. We truly appreciate your responsiveness and proactive approach to working together with local citizens on this to benefit the health and quality of life of everyone in Menlo Park for years to come.

With best regards,  
Maria Amundson

**Priorities**

Ref #. Project	Project overview	7/31 update	Project lead
01. Redistricting	Every ten years, local governments use new census data to redraw their district lines to reflect how local populations have changed. Assembly Bill 849 (2019) requires cities and counties to engage communities in the redistricting process by holding public hearings and/or workshops and doing public outreach, including to non- English-speaking communities.	Project is proceeding as planned.	Judi A Herren
02. Reimagining public safety	Project scope has yet to be established. Requires City Council direction.	Initial "kick-off" meeting completed as Council Study Session on 7/29. A snapshot of current department function and overview of national narrative in relation to MPPD was reviewed. A Subcommittee for Reimagining Public Safety was Identified as Councilmembers Taylor and Wolosin, City Manager and Police Chief.	Dave Norris
03. CAP #1 - Explore policy/program options to convert 95% of existing buildings to all-electric by 2030	Achieve the following milestones to project completion: 1. May 2021: Complete cost effectiveness analysis on various policy/program pathways toward achieving 95% electrification by 2030. 2. June 2021: Environmental Quality Commission provides advice to City Council on cost effectiveness analysis and potential pathways to achieve electrification goals for existing buildings. 3. July/August 2021: City Council reviews policy/program options and EQC recommendations and directs staff on next steps.	Project milestones are completed, and city council provided direction on next steps. Staff in partnership with CAP subcommittees consisting of Vice Mayor Nash, Councilmember Wolosin, EQC members Angela Evans, Josie Gaillard, and Tom Kabat are working on identifying project scopes and timelines from City Council's direction given on August 31.	Rebecca Lucky
04. 2022 housing element and related zoning code updates and documents	Housing Elements are housing plans that are one part of the General Plan – a guide to all the ways each city, town or county is planned and managed, from our roads and sidewalks to our parks and neighborhoods. With an update required every eight years by the State of California, this Housing Element update will create a foundation for all the policies and programs related to housing. While city governments do not generally build housing themselves, they create the rules that affect where housing can be built, how much and how it is approved. Each jurisdiction's housing plan needs to help ensure that there will be enough capacity and supportive policies to meet the projected need over the next 10 years.	Project is proceeding with community engagement activities to help inform the City's land use strategy to meet the City's RHNA.	Deanna Chow

**Priorities**

Ref #. Project	Project overview	7/31 update	Project lead
05. ConnectMenlo community amenities list update		CAO drafted CA regulations. CDD staff needs to prepare revisions to list based on prior direction from City Council.	Nira Doherty
06. Menlo Park Community Campus building	In December 2019, the City Council received a proposal from Facebook Inc. proposing to explore funding and development of a new multi-generational community center and library located in Menlo Park's Belle Haven neighborhood, replacing the existing community center, senior center, youth center, pool house, and library facilities. Identified as a City Council priority on January 28, 2020, this project would deliver the City's funding contribution to the project.	Project proceeding.	Justin Murphy
07. Reimagining downtown	Project scope has yet to be established. Requires City Council direction.	No update or anticipated timeline.	No project
08. Caltrain rail corridor quiet zone analysis	This study would fund a review of grade crossing improvements needed to consider a quiet zone along the Caltrain corridor at the Encinal and Glenwood crossings.	Work expected to begin once Associate Transportation Engineer and Assistant Public Works Director - Transportation positions are filled, tentatively expected to be late August 2021.	Nikki Nagaya
09. CAP #4 - Middle Avenue rail crossing and complete street	This project would provide a grade-separated crossing through the Caltrain railway to create a pedestrian/ bicycle connection near Middle Avenue, between Alma Street near Burgess Park and El Camino Real at the proposed open space plaza as identified in the El Camino Real/Downtown Specific Plan. The project would develop detailed design plans and construct the project. As part of the terms of the development agreement for Middle Plaza at 500 El Camino Real, Stanford University is required to make a contribution towards the cost of the project, 50 percent of the cost, up to \$5,000,000. In May 2020, the Santa Clara County Board of Supervisors also allocated \$1,000,000 in funds for this project through the Stanford University recreation mitigation fund established during the 2000 General Use Permit approvals.	Rail crossing project is proceeding. Funding requests were submitted to Representative Eshoo's office for consideration in the federal transportation infrastructure bill. Complete streets study is on hold pending capacity.	Nikki Nagaya

**Work plan**

Ref #. Project	Project overview	7/31 update	Project lead
10. Racial equity - NLC REAL program and baseline project	Created in 2015 in the wake of social unrest in Ferguson, Missouri, NLC's Race, Equity And Leadership (REAL) program helps to empower and equip local officials with tools to address racial disparities in their communities. As local leaders look to reimagine government policies, procedures, and processes to build more equitable communities, REAL is available to help cities and towns learn the impact of historical inequities and design programs that dismantle structural and system racism. REAL provides training with local elected officials and municipal staff, seminars for municipal staff and local elected officials, customized training to match city needs.	Project manager identified and will start in August to prepare a project timeline with NLC and return to City Council in Fall 2021 with an implementation plan.	Nick Pegueros
11. CAP #2 - Set citywide goal for increasing EVs and decreasing gasoline sales	Defer implementation to the Beyond Gas Initiative (BGI)8 under Joint Venture Silicon Valley. Staff will continue to work with BGI within current staff capacity using existing communication mediums to promote and market information from BGI.	The goal is established and adopted through the Climate Action Plan. Staff continues to monitor the effectiveness of incentives through the annual 2030 climate action progress report that will be provided to City Council in October. The Beyond Gas Initiative under Joint Venture Silicon Valley is currently leading this effort. Staff will continue to work with BGI going forward, and report efforts in the annual 2030 Climate Action Plan progress report.	Rebecca Lucky
12. CAP #3 - Expand access to electric vehicle charging for multifamily and commercial properties	Resources will be used to monitor the effectiveness of state and regional charging infrastructure incentives, and the City will promote/market the incentives to multifamily property owners using existing databases and communication mediums. In addition, \$5,000 to \$10,000 in additional incentives will be allocated to further motivate at least two multifamily property owners with existing units/buildings to install EV charging infrastructure.	EV charging stations have been included in the design of the Menlo Park Community Campus and will be able to charge 27 vehicles once complete. In addition, some of the charging stations will be able to charge vehicles in the event of a power outage providing additional resiliency at this site. The incentive project for multifamily will kick-off in the Fall. This project was on hold due to completing CAP No.1, resource constraints, and completing the annual progress report.	Rebecca Lucky
13. CAP #4 - Reduce vehicle miles traveled (VMT) by 25% or an amount recommended by the Complete Streets Commission	Resources will be used to focus on current work underway that would reduce VMT that includes the SB2 Housing grant, completion of the Transportation Management Association feasibility study, and implementation of VMT guidelines for new development adopted in June 2020. In addition, the Complete the Streets Commission's work plan includes prioritizing projects in the Transportation Master Plan that would reduce VMT. The Complete Streets Commission two-year work plan will be amended to include a future work effort to set a VMT reduction target in 2022 dependent upon staff resourcing to support this effort, provided it does not impact delivery of capital projects planned for the same timeframe.	Not available.	Rebecca Lucky

**Work plan**

Ref #. Project	Project overview	7/31 update	Project lead
14. CAP #4a - Transportation management association (TMA) formation	The goal of a TMA is to coordinate logistics and TDM services amongst multiple member businesses. Instead of an individual business providing TDM services for their employees, a TMA allows multiple businesses to share TDM resources. TDM services may not be cost-effective and well-utilized at individual businesses, so a TMA creates cost-efficiency and a shared burden amongst everyone, allowing smaller businesses to access some services that they would normally not be affordable.	The draft feasibility study has been completed. Staff will schedule for a future City Council meeting for review and approval in fall 2021.	Rebecca Lucky
15. CAP #5 - Eliminate the use of fossil fuels from municipal operations	Utilize current resources and available budget toward eliminating fossil fuels in building the new Menlo Park Community Campus. In addition, if there are fossil fuel appliances or assets at the end of its life, a non-fossil fuel option as a replacement will be the default unless infeasible. Additional appropriations may be required for non-fossil fuel assets or appliances that have a cost premium. Specifically in 2021-22, the City will focus on expanding a pilot program to transition landscaping equipment from gas to electric. In future years, as City contractor agreements are procured, the City will incorporate a request for landscaping equipment as well. A Sustainable Fleet Policy was adopted in 2020. There will be additional opportunities for comprehensive non-fossil fuel asset or appliance replacement planning through the upcoming Corporation Yard Master Plan and Facilities Maintenance Master Plan, subject to funding in the 2021-22 capital improvement plan.	The RFP to install a renewable microgrid with battery storage at the MPCC was successful, and a preferred vendor has been identified. It is anticipated that an award of contract will occur before the winter holidays. In addition, a sustainability consultant was hired to support various aspects of this CAP goal.	Rebecca Lucky
16. CAP #6 - Develop a climate adaptation plan to protect the community from sea level rise and flooding	Continue to participate in and monitor One Shoreline, a flood and sea level rise resiliency district, that was formed to support planning and mitigation measures for coastal erosion, sea level rise, and flooding threats up to 2100. Menlo Park is a member of this agency and pays dues annually through funds provided in the capital improvement plan. This work covers Menlo Park's neighborhoods adjacent to the bay and creeks. In February 2021, One Shoreline's board of directors authorized the Bayfront Canal and Atherton Channel Flood Protection and Ecosystem Restoration project to go out to bid. Bidding is currently underway for pre-qualified bidders and construction is expected to begin in mid-2021. Resources will be utilized to continue to actively work with neighboring communities and other agencies to close gaps not addressed by the above projects and seek further funding.	Not available.	Rebecca Lucky, Nikki Nagaya, Justin Murphy, Deanna Chow, Brian Henry

**Work plan**

Ref #. Project	Project overview	7/31 update	Project lead
17. CAP #6a - Menlo Park SAFER Bay implementation	This project provides funds to support the staff time needed to continue to implement SAFER Bay. In September 2020, PG&E approached the City about partnering on a FEMA grant opportunity to address sea level rise impacting the Ravenswood Electrical Substation consistent with the SAFER Bay project and the recently completed Dumbarton Bridge West Approach + Adjacent Communities Resilience Study. Following initial coordination, the City, SFCJPA and PG&E also reached out Facebook to consider providing additional funding to expand the project. The FEMA grant is a program offering up to \$50 million per project to reduce risks from disasters and natural hazards. The City Council authorized a letter of support for the application on November 17, 2020. PG&E, the SFCJPA, Facebook and the City collaborated on the required documentation for a Building Resilient Infrastructure and Communities (BRIC) application, which was submitted to CalOES by December 3, 2020. Cal OES submitted the grant application for FEMA consideration on January 27. FEMA notifications on awarded projects are expected in summer 2021.	The City was notified by FEMA in early July that the project was selected for further evaluation. Staff is preparing a draft memorandum of understanding with the project partners. Planning City Council in October 2021.	Rebecca Lucky, Nikki Nagaya
18. Public health advocacy (COVID-19, mental health)	Project scope has yet to be established. Requires City Council direction.	No update or anticipated timeline.	Nick Pegueros
19. Caltrain grade separation	The existing Ravenswood Avenue Caltrain crossing is a critical rail crossing within Menlo Park. It is within the El Camino Real/Downtown Specific Plan Area and falls within the City's Priority Development Area. The project would fund the additional scope of work requested by the City Council in 2018 to evaluate a fully elevated alternative and advance engineering design of a chosen preferred alternative.	Work expected to begin once Associate Transportation Engineer and Assistant Public Works Director - Transportation positions are filled, tentatively expected to be late August 2021. This project would be prioritized after work plan item 8, Caltrain rail corridor quiet zone analysis and item 9, Middle Avenue rail crossing and complete streets study.	Nikki Nagaya
20. Willow Road traffic calming	Project scope has yet to be established. Requires City Council direction.	No update or anticipated timeline.	Nikki Nagaya



**New projects, unprioritized**

Ref #. Project	Project overview	7/31 update	Project lead
Coleman and Ringwood Avenues Transportation Study	Joint project with San Mateo County to evaluate traffic calming and multimodal safety improvement options for Coleman and Ringwood Avenues.	<p>Since approval of the City Council work plan and CIP, staff has been approached by San Mateo County to partner on a Transportation Study for Coleman and Ringwood Avenues to evaluate traffic calming and multi-modal safety measures. Coleman Avenue is within both the City and County jurisdiction and is used by students and families to access schools in the area. Ringwood Avenue is primarily within the County with small segments within the City and the Town of Atherton. The City's Transportation Master Plan identified four projects for Coleman and Ringwood Avenues. Given this opportunity to work with the County to better coordinate projects for both streets, staff recommends adding this joint project to the Council work plan.</p> <p>Staff expects that adding this project will impact other CIP projects, specifically the Middlefield Road paving project and the Caltrain grade separation project, neither of which is currently active. The Middlefield Road project (to be staffed by both the transportation and engineering teams) is already delayed due to staff vacancies in the engineering team. This creates an opportunity to focus staff time on a project that would be primarily managed by the transportation team. The Caltrain grade separation project is currently on hold, and staff expects that restarting this project would be further delayed. However, staff has started work on the Caltrain quiet zone analysis which will address safety around the Caltrain corridor and is a current City Council priority. If City Council agrees</p>	Hugh Louch