

## **Community Development**

701 Laurel St.

Menlo Park, CA 94025

650-330-6740

## **PARKING STALLS AND DRIVEWAY DESIGN GUIDELINES**

On March 18, 1996, the Planning Commission adopted guidelines for parking stalls and driveways. The guidelines standardize parking stall width dimensions and establish design criteria for review of driveway and parking lot circulation requests.

### **General Considerations**

#### **Parking Stall Dimensions:**

Changes in the vehicle size have changed the parking space dimensions necessary to accommodate large cars and small cars. These vehicle changes have also reduced the aisle width requirements to access a parking stall. Large cars typically need approximately 9 feet of stall width to provide sufficient door opening width, and small cars need approximately 8 feet of stall width.

The one-size-fits-all designs are easier to execute for several reasons: 1) most drivers do not know the size of the vehicle or whether it is a large or small car; 2) most drivers take the first available space regardless of size; and 3) large cars parked in small-car spaces create problems by encroaching on adjacent spaces and possibly on the adjoining aisles.

- The Parking guidelines utilize a one-size-fits-all width of 8 feet 6 inches.

#### **Driveway Design:**

The safety and efficiency of a street depends on the amount and character of interference affecting vehicles moving along it. Significant interference is caused on most roads by vehicles entering, leaving, or crossing at intersecting streets and driveways. In order to minimize accidents and to assure best overall use of the road by the general public, it is necessary to regulate vehicle movements in and out of abutting developments and cross streets.

- The conflict effect of driveways is a function of traffic and pedestrian flow along the street and at the driveway.
- A low volume driveway causes relatively little conflict on a major street, and a high volume driveway causes little conflict on a minor route.
- In areas of high pedestrian activity, designs for low speed vehicular entry and exit may be based on radii and restricted total widths.
- Driveways should be designed for curb lane access with minimal encroachment on travel lanes.
- Design elements of each driveway (location, spacing, sight distance, throat width, radii, angles, and grades) should be based on expected volumes and vehicle characteristics.
- For right-turn entry and exit, the driveway radius should be consistent with the design vehicles sweep path requirements.
- Most driveway design elements are directly related to the layout of the parking area, amount of reservoir space, types of loading facility, circulation pattern, and building placement within the site.

Please refer to the attached *Parking Area Design Guidelines, Handicap Parking Design Guidelines, Driveway Design Guidelines, and Driveways Grade Guidelines* information sheets for specifications and detailed information.

Source: The Dimensions of Parking - Urban Land Institute  
National Parking Association, 1993

Parking Lot

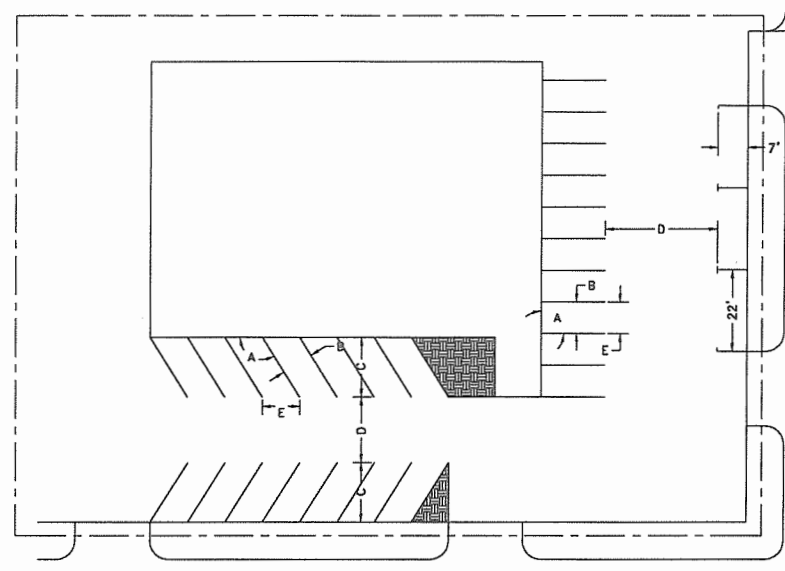

Parking Stall

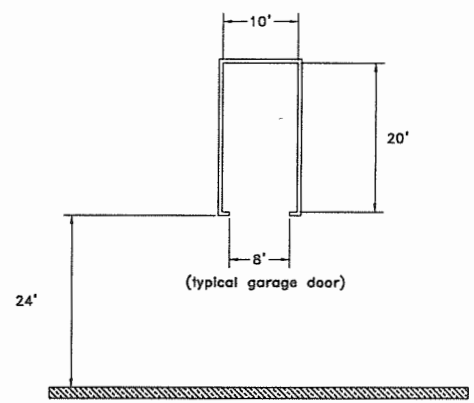

MINIMUM MODULE WIDTH (F)  
FACE OF CURB

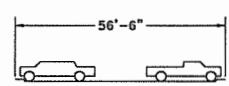

FACE OF CURB  
\*\* FOR 8.5' STALL WIDTH, TWO WAY

Angle (Degrees) A	Width of Stall (B)	Stall 90 to Aisle (C)	Minimum Width of Aisle (D)		Width Stall, Parallel to Aisle (E)	Minimum Module Width (F)	
			One Way	Two Way		One Way	Two Way
0 (parallel)	7'-0"	22'-0"	-	-	-	-	-
45	8'-6"	16'-6"	12'-6"	20'	12'	45'-6"	53'
60	8'-6"	18'	14'-6"	20'	9'-10"	50'-6"	56'
75	8'-6"	18'	18'-6"	20'	8'-10"	54'-6"	56'
90	8'-6"	16'-6"	N/A	23'	8'-6"	N/A	56'

1. The Planning Commission reserves the right to modify the parking lot layout if, in their opinion, the layout illustrates a poor design but complies with the parking guidelines.
2. The Transportation Manager shall have the authority to alter these design guidelines if, in the opinion of the Transportation Manager, it is in the best interest of public safety.
3. Parking stalls that are adjacent to physical obstructions such as walls or utility devices must have an additional 1 foot of width for the parking stall.
4. Parking stalls in a single or two car garage should have minimum dimensions of 10' x 20' each. The back up area should be a minimum of 24' for an 8 foot garage door.

prkstd6b.dwg

<h1>Transportation Division</h1> <h2>CITY OF MENLO PARK</h2> <p>PARKING AREA DESIGN GUIDELINES</p>	APPROVED:
	DATE: 3/28/96

FIGURE 1 SINGLE PARKING STALLS

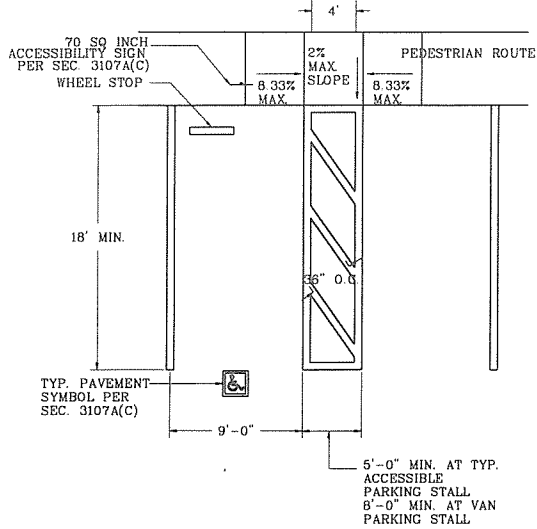

FIGURE 2 DOUBLE PARKING STALLS

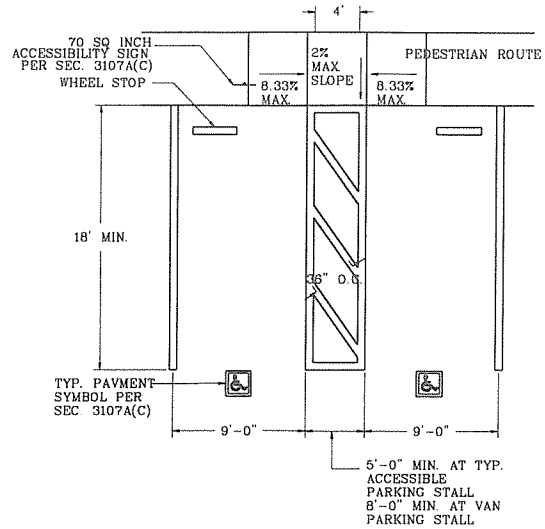

FIGURE 3 DIAGONAL PARKING STALLS

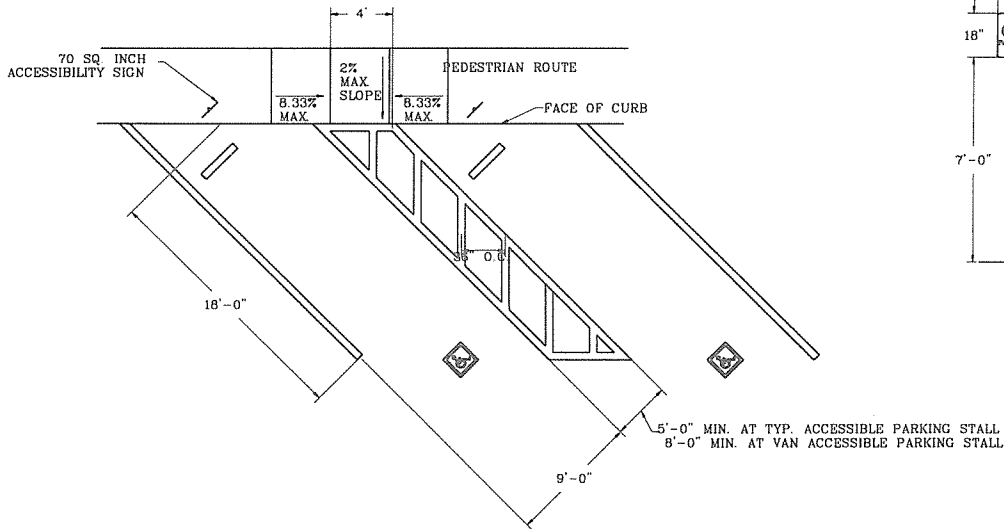
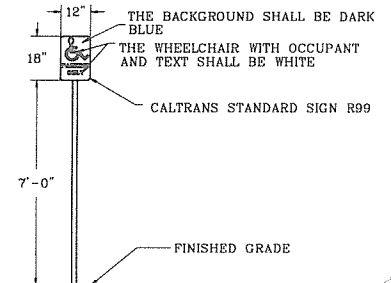

FIGURE 4 POSTED SIGN



NOTES:

1. One in every eight accessible spaces, but not less than one, shall be served by an access aisle 8 feet wide and shall be designated van accessible.
2. Each accessible parking space shall be identified by a permanent reflectorized sign adjacent to and visible from each space. The sign shall contain a profile view of a wheelchair with occupant in white on a dark blue background. The sign shall not be smaller than 70 square inches and when in a path of travel shall be posted at a minimum height of 7 feet above finished grade (see figure 4).
3. Care should be taken to avoid creating an undulating sidewalk when there are more than two Handicap spaces in a row.

REQUIRED NUMBER OF DISABLED SPACES:

Total Number of Parking Spaces in Lot or Garage	Minimum Required Number of Spaces
1 to 25	1
26 to 50	2
51 to 75	3
76 to 100	4
101 to 150	5
151 to 200	6
201 to 300	7
301 to 400	8
401 to 500	9
501 to 1000	*
1001 & over	**
* Two percent of total	
** Twenty plus one for each 100, or fraction thereof over 100	

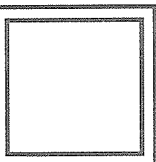

dsable2.dwg

**Transportation Division**  
**CITY OF MENLO PARK**  
**HANDICAP PARKING DESIGN GUIDELINES**

APPROVED:   
 Transportation Manager  
 DATE: 3/28/96

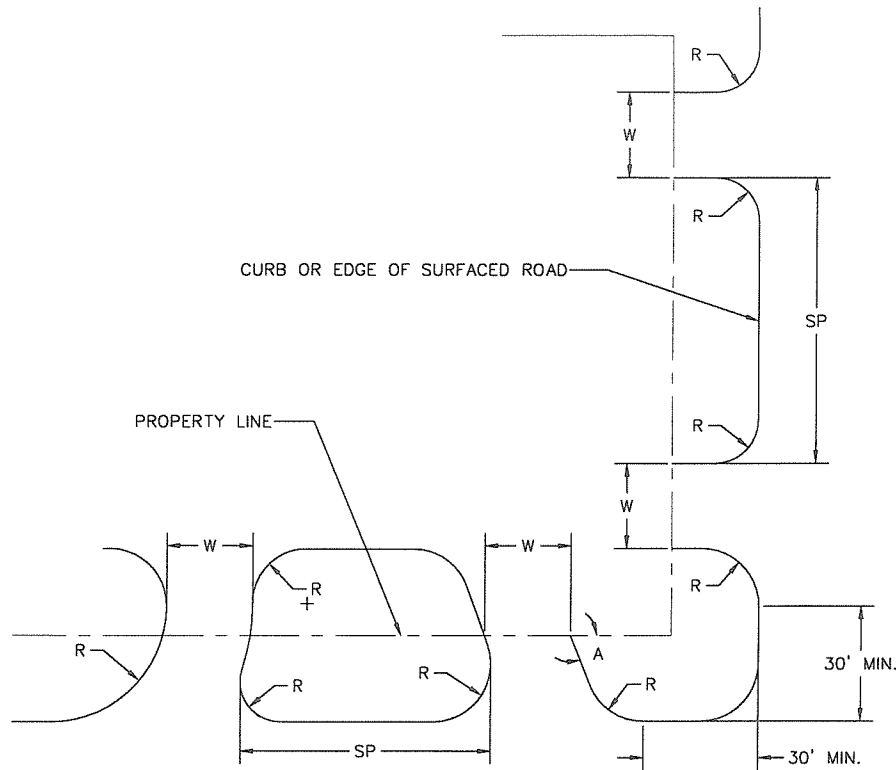

DRIVEWAY APPROACH STANDARDS:

Type	Width (W) ft.		Radius (R) ft.		Min. Spacing (SP) ft. Between Drives
	Min.	Max.	Min.	Max.	
<u>Residential</u>					
Single Family	10	24	5 (FLARE)	10 (FLARE)	10
Multi-family	24	36	10	15	20
<u>Commercial</u>					
Office	24	36	10	15	20
Retail	24	36	10	15	40
Industrial	24	50	10	20	40

GENERAL REQUIREMENTS

1. One-way commercial driveways shall meet the same standards as two-way driveways, except for width (minimum 15 ft. - maximum 25 ft.). Proper signs will be posted and maintained by the owner.
2. Driveways shall not be constructed within the curb return of street intersection. A minimum distance of 30 feet will be maintained between the point of a curb cut for driveway and the point of intersection of the projected curb lines at an intersection.
3. The angle of driveway approach shall be approximately 90 degrees to the street curb line for all two-way driveways. One-way driveways and service station driveways shall be 30 to 90 degrees.
4. No head-in-parking will be permitted for commercial driveways.
5. The Transportation Manager shall have the authority to alter these design standards or to deny issuance of a permit if, in the opinion of the Transportation Manager, it is in the best interest of public safety. Deviation from the driveway approach standards would take into consideration the peak driveway approach volume and the driveway storage capacity in conjunction with the peak street volume and the street storage capacity.

dwapstd.dwg

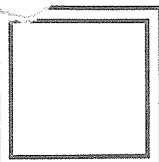

TRANSPORTATION DIVISION  
CITY OF MENLO PARK

DRIVEWAY DESIGN GUIDELINES

APPROVED:

*[Signature]*  
Transportation Manager

DATE: 3/28/96

### DRIVEWAY DETAILS

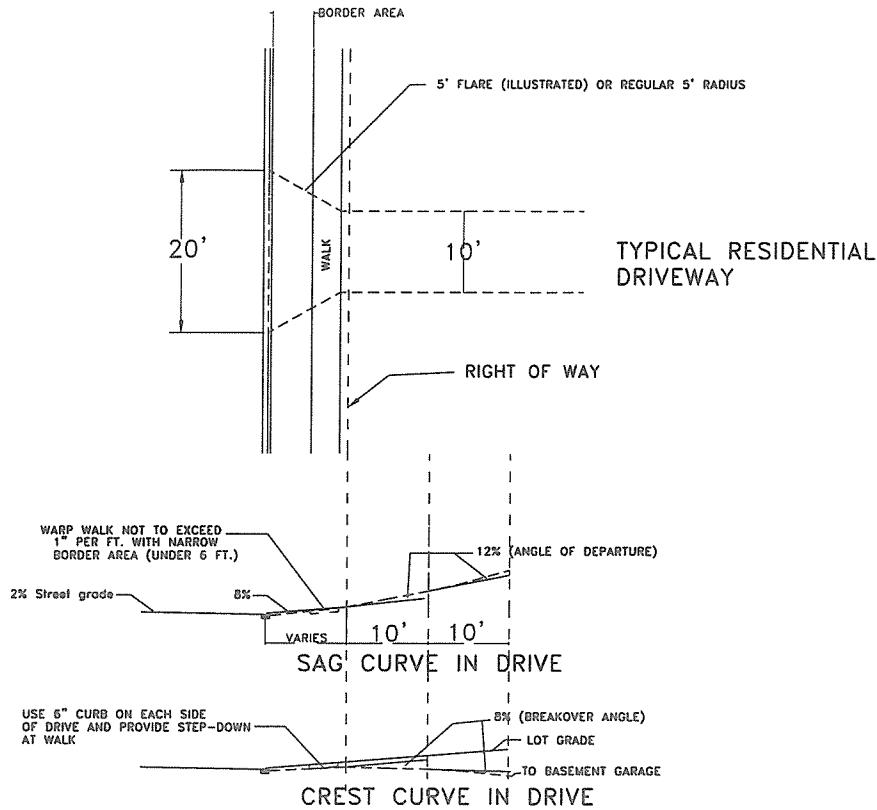

### NOTES:

#### DRIVEWAYS:

Because they are deceptively simple in appearance, driveways often do not receive adequate design consideration. Common deficiencies include:

- A. Inadequate radii at street
- B. Excessive grades and grade differences (breakover angles).
- C. Inadequate width.

The typical residential driveway should be designed for passenger-car operation only. For a 90-degree turn, an inside radius of 18 feet and an outside swept path of 30-foot radius will comfortably accommodate most drivers in all passenger cars.

- A minimum width of 10 feet is recommended for single-lane driveways. At the narrowest street width of 22 feet, such a driveway will require 12 foot radii to avoid lane encroachment. At 34-foot street width, the radius required to avoid encroachment drops to only 4 feet. Temporary encroachment on the wrong side of a minor street while entering or leaving a private driveway is generally considered allowable. This suggests a design value of about 5 feet for driveway radius.
- At high volume driveways for schools, apartments or commercial parking lots, increased widths plus radii requirements of 10-15 feet are recommended.
- The common design fault of excessive breakover angle and rear bumper dragging at the gutter line can be avoided by proper grading of the right-of-way cross section. As a general rule, the driveway grade should not exceed 8 percent within the right-of-way area. Of greater importance is the change in grade, which should not exceed 12 percent within any 10 feet of distance. Car "bottoming" on the crest can be avoided by use of 8 percent maximum change per 10 feet.

dwstdrs

TRANSPORTATION DIVISION  
CITY OF MENLO PARK

Driveway Grade Guidelines

APPROVED:

*[Signature]*  
Transportation Manager

DATE: 3/28/96