



REGULAR MEETING AGENDA

Date: 9/13/2022
Time: 6:00 p.m.
Location: [Zoom.us/join](https://zoom.us/join) – ID# 831 3316 9409

NOVEL CORONAVIRUS, COVID-19, EMERGENCY ADVISORY NOTICE

Consistent with Government Code section 54953(e), and in light of the declared state of emergency, and maximize public safety while still maintaining transparency and public access, members of the public can listen to the meeting and participate using the following methods.

How to participate in the meeting

- Submit a written comment online up to 1-hour before the meeting start time:
city.council@menlopark.org
Please include the agenda item number you are commenting on.
- Access the meeting real-time online at:
[Zoom.us/join](https://zoom.us/join) – Meeting ID 831 3316 9409
- Access the meeting real-time via telephone at:
(669) 900-6833
Meeting ID 831 3316 9409
Press *9 to raise hand to speak
- Watch meeting:
 - Cable television subscriber in Menlo Park, East Palo Alto, Atherton, and Palo Alto:
Channel 26

Note: City Council closed sessions are not broadcast online or on television and public participation is limited to the beginning of closed session.

Subject to Change: Given the current public health emergency and the rapidly evolving federal, state, county and local orders, the format of this meeting may be altered or the meeting may be canceled. You may check on the status of the meeting by visiting the City's website www.menlopark.org. The instructions for logging on to the webinar and/or the access code is subject to change. If you have difficulty accessing the webinar, please check the latest online edition of the posted agenda for updated information (menlopark.org/agenda).

According to City Council policy, all meetings of the City Council are to end by midnight unless there is a super majority vote taken by 11:00 p.m. to extend the meeting and identify the items to be considered after 11:00 p.m.

Regular Session ([Zoom.us/join](https://zoom.us/join) – ID# 831 3316 9409)

A. Call To Order

B. Roll Call

C. Agenda Review

D. Public Comment

Under “Public Comment,” the public may address the City Council on any subject not listed on the agenda. Each speaker may address the City Council once under public comment for a limit of three minutes. Please clearly state your name and address or political jurisdiction in which you live. The City Council cannot act on items not listed on the agenda and, therefore, the City Council cannot respond to non-agenda issues brought up under public comment other than to provide general information.

E. Presentations and Proclamations

E1. Proclamation: Supporting the reopening of the Mack E. Mickelson therapeutic pool ([Attachment](#))

E2. Proclamation: Recognizing September 2022 as Suicide Prevention Month ([Attachment](#))

F. Study Session

F1. Menlo Park Community Campus project updates including recreation and community programs survey results ([Staff Report #22-172-CC](#)) ([Presentation](#))

G. Consent Calendar

G1. Accept the City Council meeting minutes for July 26 and August 23, 2022 ([Attachment](#))

G2. Adopt a resolution to continue conducting the City’s Council and advisory body meetings remotely due to health and safety concerns for the public and to authorize the use of hybrid meetings ([Staff Report #22-171-CC](#))

G3. Authorize the city manager to sign the public improvement agreement for the Menlo Portal project located at 115 Independence Drive and 104 and 110 Constitution Drive ([Staff Report #22-168-CC](#))

H. Public Hearing

H1. Adopt a resolution to abandon a public utility easement at 248 Oakhurst Place ([Staff Report #22-173-CC](#)) ([Presentation](#))

I. Regular Business

I1. Provide direction on preferred Middle Avenue conceptual design and adopt a resolution to install no parking zones on Middle Avenue, install an all-way stop at Middle Avenue and San Mateo Drive, and authorize a temporary closure of Blake Street at Middle Avenue ([Staff Report #22-174-CC](#)) ([Presentation](#))

I2. Waive the first reading and introduce an ordinance repealing and replacing Menlo Park Municipal Code Section 2.04.190 relating to filling City Council vacancies and adopt a resolution establishing the process for appointment of candidates to City Council seats to fill vacancies
([Staff Report #22-170-CC](#))

I3. Adopt a resolution to approve amendments to the salary schedule as of September 25, 2022
([Staff Report #22-169-CC](#))

J. Informational Items

J1. City Council agenda topics: September – October 18, 2022 ([Staff Report #22-175-CC](#))

K. City Manager's Report

L. City Councilmember Reports

M. Adjournment

At every regular meeting of the City Council, in addition to the public comment period where the public shall have the right to address the City Council on any matters of public interest not listed on the agenda, members of the public have the right to directly address the Council on any item listed on the agenda at a time designated by the chair, either before or during the City Council's consideration of the item.

At every special meeting of the City Council, members of the public have the right to directly address the City Council on any item listed on the agenda at a time designated by the chair, either before or during consideration of the item. For appeal hearings, appellant and applicant shall each have 10 minutes for presentations.

If you challenge any of the items listed on this agenda in court, you may be limited to raising only those issues you or someone else raised at the public hearing described in this notice, or in written correspondence delivered to the City of Menlo Park at, or prior to, the public hearing.

Any writing that is distributed to a majority of the City Council by any person in connection with an agenda item is a public record (subject to any exemption under the Public Records Act) and is available by request by emailing the city clerk at jaherren@menlopark.org. Persons with disabilities, who require auxiliary aids or services in attending or participating in City Council meetings, may call the City Clerk's Office at 650-330-6620.

Agendas are posted in accordance with Government Code Section 54954.2(a) or Section 54956. Members of the public can view electronic agendas and staff reports by accessing the City website at menlopark.org/agenda and can receive email notification of agenda and staff report postings by subscribing to the "Notify Me" service at menlopark.org/notifyme. Agendas and staff reports may also be obtained by contacting City Clerk at 650-330-6620. (Posted: 9/8/2022)

Supporting the Reopening of the Mack E. Mickelson Arthritis and Rehabilitation Center Therapy Pool

WHEREAS, the Mack E. Mickelson Arthritis and Rehabilitation Center Therapy Pool is an Americans with Disabilities Act- -accessible warm water therapy pool operated by Sutter Health and located at the Mills Health Center, in San Mateo, California; and

WHEREAS, the Mickelson Therapy Pool was constructed over 25 year ago using charitable contributions from residents of San Mateo County to serve as a centerpiece of an arthritis center created by Mills Peninsula; and

WHEREAS, the Mickelson Therapy Pool has been used for over 25 years by thousands of residents of San Mateo County who suffer from a broad range of health issues, including permanent disabilities, debilitating injuries, autoimmune disorders, and mobility impairments, to rehabilitate those health issues and mitigate physical decline; and

WHEREAS, Mickelson Therapy Pool has historically provided both preventative and interventionist therapies to residents of San Mateo County suffering from health issues; and

WHEREAS, there is also an apparent and growing need for the services provided by the Mickelson Therapy Pool, due to San Mateo County's rapidly increasing number of elderly residents who are highly likely to suffer from health issues requiring a warm water therapy pool; and

WHEREAS, Mickelson Therapy Pool is the only pool of its kind in San Mateo County, and there are no comparable warm water therapy pools that can adequately accommodate the residents of San Mateo County who previously relied upon Mickelson Therapy Pool and who are now suffering from acute and chronic physical pain and mental anguish without it; and

WHEREAS, in spite of the critical need for the facility, in June 2021, Sutter Health announced that it would permanently close the Mickelson Therapy Pool to independent use by patrons and closing Mickelson removes a valuable healthcare resource for people to assist them in daily activities; and

WHEREAS, over 4,300 patients, caregivers, and community members have signed a petition to reopen the Mickelson Therapy Pool in order to increase the health, independence, and dignity of residents who rely upon it; and

WHEREAS, Sutter Health, its subsidiaries and affiliated entities receive significant financial benefits from their operations in San Mateo County and this City Council is aware that warm water therapy pools in the region are able to operate profitably and safely, including under COVID-19 protocols; and

WHEREAS, in light of the foregoing, this City Council believes that Sutter Health should be called upon to reopen the Mickelson Therapy Pool and to maintain the same open access hours that were in place prior to January 2020.

NOW, THEREFORE, IT IS HEREBY RESOLVED, that I, Betsy Nash, Mayor of the City of Menlo Park recognizes that promptly reopening the Mack E. Mickelson Arthritis and Rehabilitation Center Therapy Pool for community use with the same open access hours that it had prior to January of 2020 would preserve and improve the health of residents in San Mateo County who have historically relied upon it or who could benefit from warm water therapy to maintain their health, independence, and dignity and this City Council calls upon Sutter Health to reopen the Mickelson Therapy Pool and to maintain the same open access hours that were in place prior to January 2020.

DocuSigned by:



Betsy Nash, Mayor
September 13, 2022

Recognizing September as Suicide Prevention Month

WHEREAS, Menlo Park will join the county, state and country in honoring Suicide Prevention Month (September), National Suicide Prevention Week (September 4-10) and World Suicide Prevention Day (September 10) to spread the message that suicide can be prevented; and

WHEREAS, San Mateo County will join the country and state in honoring Suicide Prevention Month (September), National Suicide Prevention Week (September 5-11) and World Suicide Prevention Day (September 10) to spread the message that suicide can be prevented; a

WHEREAS, in 2021, 54 people died by suicide (34% decrease from 82 in 2020) in San Mateo County; and

WHEREAS: in 2020, 12,297 contacts were received by the San Mateo County StarVista Crisis Hotline. In July 2022, the StarVista Crisis Hotline received a 10% increase compared to July 2021, likely due to the debut of the 988 number on July 16.; and

WHEREAS, Menlo Park residents are urged to play a role in supporting each other and preventing suicide by knowing the signs of suicide, finding the words to communicate and reaching out to local 24/7 resources, including our local San Mateo County StarVista Crisis Hotline (650-579-0350) or National Suicide Prevention Lifeline (988 or 1-800-273-TALK); and

WHEREAS, residents can also play a role in suicide prevention by supporting local Suicide Prevention Month events, advocacy days and communication campaign. Across the city, county and state, the 2022 September Suicide Prevention Month theme is "Take Action for Suicide Prevention – Thriving at All Ages"; and

WHEREAS, beyond September, Menlo Park has joined the San Mateo County Mayors Mental Health Initiative where mayors across the 20 cities in San Mateo County have come together with the mission of promoting awareness of and access to mental health resources in their communities; and

NOW, THEREFORE, BE IT RESOLVED that I, Betsy Nash, Mayor of the City of Menlo Park, State of California, hereby designates September 2022 as Suicide Prevention Month and calls upon everyone in our community to find their role in suicide prevention.

DocuSigned by:

Betsy Nash

415F4B216DBF480...

Betsy Nash, Mayor
September 13, 2022



STAFF REPORT

City Council

Meeting Date:

9/13/2022

Staff Report Number:

22-172-CC

Study Session:

Menlo Park Community Campus project updates including recreation and community programs survey results

Recommendation

Staff recommends that the City Council review this report containing updates about the Menlo Park Community Campus (MPCC) project, including the results of a survey of Menlo Park residents' needs and desires for recreation and community programs. Staff seeks feedback and direction from City Council about the findings of the resident survey to help inform and shape the planning for operations and programming in the MPCC.

Policy Issues

City Council sets policy and goals and provides direction to staff regarding municipal projects and services to the Menlo Park community. City Council established the MPCC project as one of the City's top priorities.

Background

On December 16, 2019, Facebook (now Meta) submitted its proposal for exploring the funding and development of a new multigenerational center to incorporate the former Onetta Harris Community Center, Menlo Park Senior Center, Belle Haven Youth Center (child care), Belle Haven Pool and branch library.

On January 12, 2021, City Council approved the architectural control, use permit, funding and improvements agreement for the MPCC project located at 100-110 Terminal Avenue. City Council requested further review of several design elements of the proposed pool area. Those items were discussed January 26, 2021, and February 1, 2021. City Council approved the pool design elements February 1, 2021.

Construction of the MPCC project began in November 2021. The project's concrete foundation was completed in March 2022 and the steel framing was completed in April 2022.

City Council created the MPCC subcommittee to work with City staff and the community on the MPCC project. The MPCC Subcommittee is currently comprised of Mayor Nash and City Councilmember Taylor. The MPCC subcommittee convened a working group of Menlo Park residents to support and advise the subcommittee's work.

On May 24, 2022, City Council reviewed an informational report containing MPCC project updates and a draft survey of Menlo Park residents' needs and interests related to recreation and community programming in the MPCC.

On August 23, 2022, City Council reviewed aquatics-related excerpts from the above-noted survey.

Analysis

The MPCC project is entering an exciting new phase. The long-held dream of a new community campus in Belle Haven is visibly taking shape as the construction progresses and an inspiring new landmark rises at 100 Terminal Avenue. Planning for the programming and operations of the new campus is proceeding apace with robust community involvement and input. With the project moving into a particularly active phase of development, staff anticipates providing updates to the MPCC Subcommittee and City Council on a regular basis going forward.

Resident survey – recreation and community programs

City Council February 8, 2022, directed staff to conduct an analysis of the city’s aquatics program needs at Burgess Pool and the future MPCC aquatics center, including a survey of Menlo Park residents. The MPCC Subcommittee, currently comprised of Mayor Nash and City Councilmember Taylor, subsequently expressed interest in leveraging the opportunity of a resident survey to also gain insight into residents’ needs and interests related to recreation and community programming in the MPCC.

Staff prepared a resident survey to gain insight in all these areas, with input from the MPCC Subcommittee and its working group of Belle Haven residents, the Library Commission, and the Parks and Recreation Commission. Staff transmitted the survey questions to City Council for review May 24. The survey opened June 13 and was distributed to Menlo Park residents in electronic and paper formats, in English and Spanish. The survey had over 900 respondents by the time the survey closed August 10.

The complete survey results are attached to this report. (Attachment A).

Several of the questions asked survey respondents to rate items as either "not at all important," "somewhat important," or "very important." Responses of "not at all important" were assigned a numeric value of 1; "somewhat important" were assigned a value of 2; and "very important" were assigned a value of 3. The charts in Attachment A show these weighted average ratings for each item. Higher ratings indicate that survey respondents overall assigned higher relative importance to those items. Items that were rated with high average relative importance (2.35 or higher) are summarized in the following Table 1:

| Table 1: High average relative importance (2.35 or higher) | |
|--|---|
| Survey rating | Item |
| 2.78 | Wireless internet access (Wi-Fi) in the library |
| 2.74 | Quiet places to read and study |
| 2.67 | Books in paper format |
| 2.67 | Storytimes for young children |
| 2.67 | [Athletic] Programs are focused on the needs of Menlo Park residents |
| 2.65 | Swimming pools are open year-round |
| 2.64 | Swimming pools are open seven days per week |
| 2.63 | Swimming pools are focused on the needs of Menlo Park residents |
| 2.62 | Neighborhood / family access to athletic fields for casual use and play |



| | |
|------|--|
| 2.59 | [Community] Programs/ classes are focused on the needs of Menlo Park residents |
| 2.59 | Books that are the newest and most popular bestsellers |
| 2.59 | Swimming lessons for children |
| 2.56 | Children access to athletic fields for casual / drop-in play |
| 2.55 | Teens have space to socialize, read and study after school and weekends |
| 2.55 | Books that offer a wide range of different viewpoints including views I don't agree with |
| 2.55 | Books that reflect the cultures, needs and interests of local / neighborhood residents |
| 2.54 | Open swim / community swim time in big pool |
| 2.52 | Swimming pools have free or discounted fees for Menlo Park residents |
| 2.52 | Books in electronic / digital formats (e-books, e-audiobooks) |
| 2.51 | Homework help for children and teens after school |
| 2.5 | [Athletic] Programs are free or have discounted fees for Menlo Park residents |
| 2.45 | Adult lap swimming |
| 2.45 | [Community] Programs/ classes are free or have discounted fees for Menlo Park residents |
| 2.43 | English as Second Language (ESL) resources |
| 2.42 | Adult literacy tutoring to help adults learn how to read / improve reading skills |
| 2.42 | Job skills / job readiness / job seeker resources and training |
| 2.39 | Books that are classics that I read in school / as a child |
| 2.36 | Food distribution, food insecurity advice and support |
| 2.35 | Health care navigation and support |
| 2.35 | Music / performing arts |
| 2.35 | Health and wellness / yoga / meditation |

Lower ratings indicate that survey respondents assigned lower relative importance to those items. Items that were rated with low average relative importance (1.90 or lower) are summarized in the following Table 2:

| Table 2: Low average relative importance (1.90 or lower) | |
|--|--|
| Survey rating | Item |
| 1.75 | Football/ rugby – organized youth/adult league |
| 1.83 | Money management, personal budgeting |
| 1.84 | Swimming pools attract participants from outside Menlo Park who are charged higher fees |
| 1.85 | Competitive swimming / sports have priority to use the pools for training and competitions |
| 1.86 | Lacrosse – organized youth league |
| 1.87 | Martial arts |
| 1.88 | [Athletic] Programs attract participants from outside Menlo Park who are charged higher fees |
| 1.88 | [Community] Programs/ classes attract participants from outside Menlo Park who are charged higher fees |

Informed by the resident survey results and consistent with previous direction received from City Council related to MPCC programming, staff will continue to work with stakeholders including the MPCC Subcommittee and working group, Library Commission, and Parks and Recreation Commission to incorporate the following considerations into the MPCC program planning. Staff seeks City Council’s feedback and direction on these considerations as well as any other elements that City Council desires to incorporate into the program planning process. The following considerations are numbered for convenience only, and are in no particular order or priority:

1. Prioritize the program elements that survey respondents rated with the highest relative importance.
2. Include programs and classes that are not currently offered on a regular basis, but were rated with high importance by survey respondents. For example:
 - A. Homework help for children and teens after school
 - B. Job skills / job readiness / job seeker resources and training
 - C. Food insecurity advice and support
 - D. Health care navigation and support
3. Prioritize programs and classes that are free or have discounted fees for Menlo Park residents.
4. Deprioritize programs that primarily attract participants from outside Menlo Park, and/or that survey respondents rated with low relative importance
5. Prioritize casual and drop-in play opportunities for children and families, especially Menlo Park residents
6. Aquatics program considerations will be addressed in the context of the upcoming aquatics operator request for proposals (RFP) process.

Staff will incorporate City Council’s feedback and direction into the planning process and will present preliminary MPCC staffing and program options to City Council tentatively in January/February 2023.

MPCC environmental sustainability features

The MPCC project is being designed to LEED Platinum standards for environmental sustainability – the highest available designation. The Library Commission and Parks and Recreation Commission on June 22 convened a joint study session to receive updates about the MPCC project and invite public input. Among the items reviewed at the June 22 joint study session was a presentation by project architects Hart Howerton about the MPCC project’s many environmental sustainability features (Attachment B).



MPCC furnishing layouts

The MPCC subcommittee and working group requested additional visual aids that show the proposed furnishings in layout. City staff worked with the architects to develop several “dollhouse” visualizations that show the proposed furnishings to scale in a “3-D” format that is visually engaging and, hopefully, clearer and more evocative than the standard two-dimensional diagrammatic view (Attachment C).

Construction tours

Residents and other interested parties are invited to participate in neighborhood-oriented tours of the MPCC construction site. The intent of the tours is to provide Menlo Park residents, especially from the Belle Haven neighborhood, the opportunity to observe and experience the project while it is under construction. Tours have been scheduled at various stages of the project construction. The first tour took place on August 19 and was well-attended by neighborhood residents. All tours take place on afternoons after construction work has ended for the day.

- Friday, October 21 – This tour will feature the interior stairs and passageways and a walkthrough of the structure
- Friday, January 6 – Tour of the swimming pools and splash pad under construction, in addition to a walkthrough of the main structure
- Friday, March 10 – Focus on the gymnasium and other major interior rooms, in addition to a walkthrough of the structure

Tour participants must be 18 years of age or older. Advance registration and liability waiver are required. The MPCC project is an active construction site with uneven surfaces and other potential hazards. Sturdy footwear is required. Personal protective equipment (hard hats, hi-visibility vests) will be provided.

MPCC project timeline

The MPCC project construction began in November 2021 and the construction work is proceeding at a brisk pace. Currently, unprecedented supply chain issues are prevalent throughout the construction industry, and continue to impact the timely availability of critically important infrastructure, equipment and materials. There are potential supply chain delays with critical electrical infrastructure equipment, and the team is exploring all available options to avoid these potential delays. In the event that this electrical infrastructure equipment needed for the MPCC project are delayed due to supply chain issues, the project’s completion timeline will shift by several months to late 2023 or early 2024.

Beechwood School temporary entrance change and Kelly Park access

As part of the ongoing construction for the MPCC project, the Beechwood School parking lot will be under construction from late August to December 2022. The construction activity involves trenching and underground utility work. Access to Kelly Park will still be available by pedestrian walk path. Cars entering and exiting Kelly Park will have limited parking spaces at the field and are asked to carpool, use public transit or bike to help ease traffic congestion. During construction, access to Beechwood School will be shifted to an alternate entrance at 243 Terminal Avenue. To help reduce traffic impacts during school drop-off/pick up times, the City created a temporary school loading zone on the north side of Terminal Avenue, between Plumas Avenue and Modoc Avenue.

Parking management plan

Staff has begun to develop a parking management plan and options for City Council to consider related to the MPCC parking areas. Parking considerations could include time limited parking to ensure parking is used by visitors, designating certain parking spaces during certain times of day, and potentially restricting overnight parking. Other considerations could tentatively include: quantity and location of bicycle parking, pedestrian routes, and other factors that pertain to the management of the parking area. Key elements of the planning process include: review relevant past parking studies and data; conduct public outreach to

gather community input; develop a draft plan for review by the Complete Streets Commission; then present a final draft plan to City Council review and approval targeted in January/February 2023.

Pool heat pumps and exception to noise ordinance

To meet City Council's goals of sustainable design and construction for the MPCC project, no fossil fuels will be consumed in the operation of the building. To heat the two new pools, the project plans call for five air source heat pumps (ASHPs), which will be in operation when heating the pool, year round. Several studies were undertaken to carefully select the most efficient and capable equipment, while minimizing the amount of noise created. Electrical heating equipment generates more noise than natural gas boilers. As a result, there will be times when the electric-powered ASHPs are running and exceed the Menlo Park noise ordinance. The project team evaluated several noise mitigation strategies, including:

- Aftermarket attenuators (dampeners) attached to the ASHPs to lower the output would not work sufficiently to lower the sound levels
- Sound walls installed surrounding the ASHPs. The proximity of the ASHPs to the property line on the south (and clearance required by the ASHPs for air circulation), the gymnasium to the north, and required fire access clearance required on the East and West do not make it possible to install effective sound barriers anywhere on site.
- Other solutions such as relocating pumps to the pool house area increased the sound limits at the residential property lines, making alternatives infeasible.

Based on the above findings, the project team determined that it is infeasible to mitigate the noise to levels that comply with the noise ordinance. Staff is preparing to seek an exception to the noise ordinance at the Planning Commission tentatively in October 2022.

Upcoming City Council items

Items relevant to the MPCC project are tentatively scheduled for City Council review and/or approval in the coming months.

- September/October – Authorize staff to issue a RFP for an aquatics operator at Burgess Pool and the new MPCC Pool
- November/December – Provide direction for updating City Council Policy CC-86-0001, "Naming and/or changing the name of facilities" (1986)
- December/January – Award of contract and budget authorization for procurement of furnishings and non-fixed equipment for the MPCC
- January/February – Preliminary options for parking management plan
- January/February – Preliminary considerations for MPCC staffing and operations

Impact on City Resources

Staff estimates the value of Meta's contribution toward the MPCC project completion at approximately \$40 million. The City's share of the project construction includes commitments at both a base level and project enhancements totaling approximately \$15.75 million from various funding sources authorized by the City Council project approvals January 12, 2021 and February 1, 2021. The ongoing cost impacts of operating the new center will be established over the next several months as part of the MPCC operational planning process. As part of the new center opening, it is anticipated that existing services that are currently housed in interim locations will be relocated to the new center; some services that were suspended or reduced during the MPCC construction and/or due to pandemic impacts would likely be restored to pre-construction/pre-pandemic levels; and some service level enhancements could be necessary or desired in order to operate the center in the manner and capacity envisioned by the City Council and the community.

The intent is to engage the community over the next several months through the MPCC operational planning process to identify what is desired regarding the center's programs and operations, which can then inform projected operating costs for the City Council to make budgeting decisions during fiscal year 2022-23.

Environmental Review

On January 12, 2021, the City Council found the MPCC project categorically exempt pursuant to the California Environmental Quality Act (CEQA) Guidelines Section 15302 Replacement of Existing Facilities. The project has substantially the same purpose and capacity as the existing facilities, and this exemption allows for reasonable increases in square footage to accommodate replacement facilities. On January 21, 2021, staff filed a notice of exemption with the San Mateo County Clerk.

Public Notice

Public notification was achieved by posting the agenda, with the agenda items being listed, at least 72 hours prior to the meeting. In addition, the City sent electronic notices via Nextdoor, Facebook and directly to project email and text update subscribers from the project page (Attachment D).

Attachments

- A. Resident survey – recreation and community programs
- B. Sustainability presentation
- C. Furniture layouts
- D. Hyperlink – project page: <https://menlopark.org/communitycampus>

Report prepared by:
Sean Reinhart, Library and Community Services Director

1. What neighborhood of Menlo Park do you live in now?

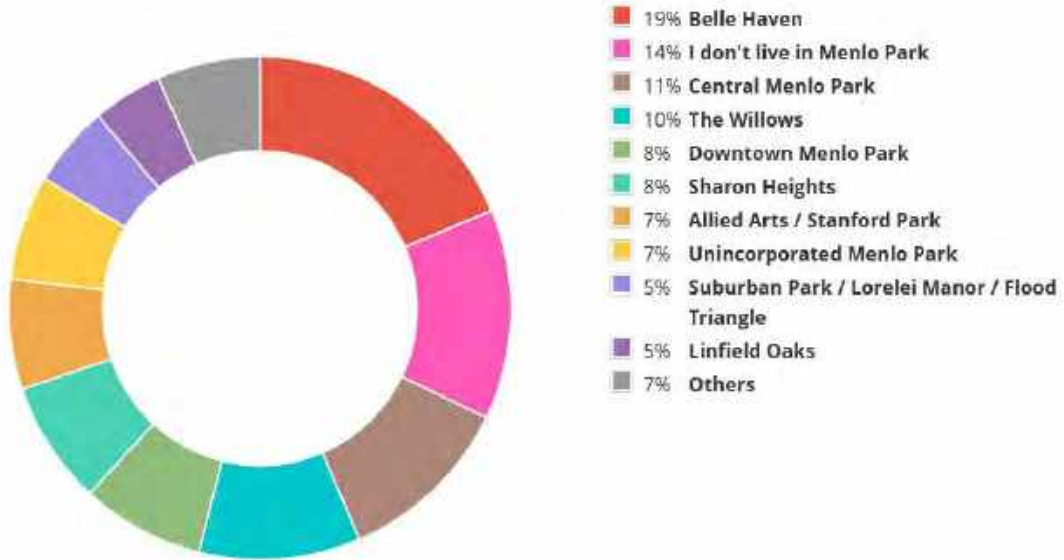

932 respondents

2. How long have you lived in Menlo Park?

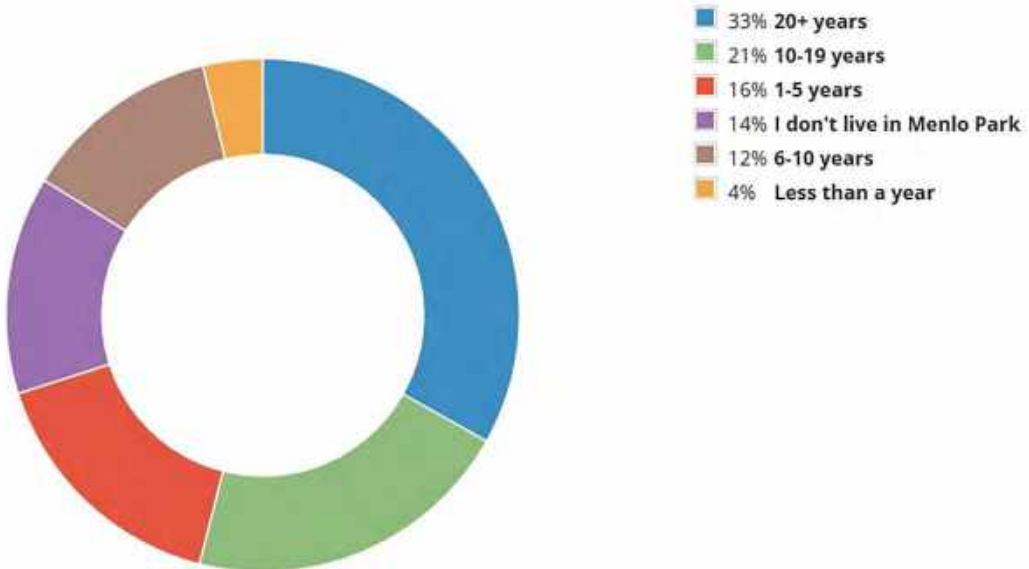

932 respondents

18. What is your age?

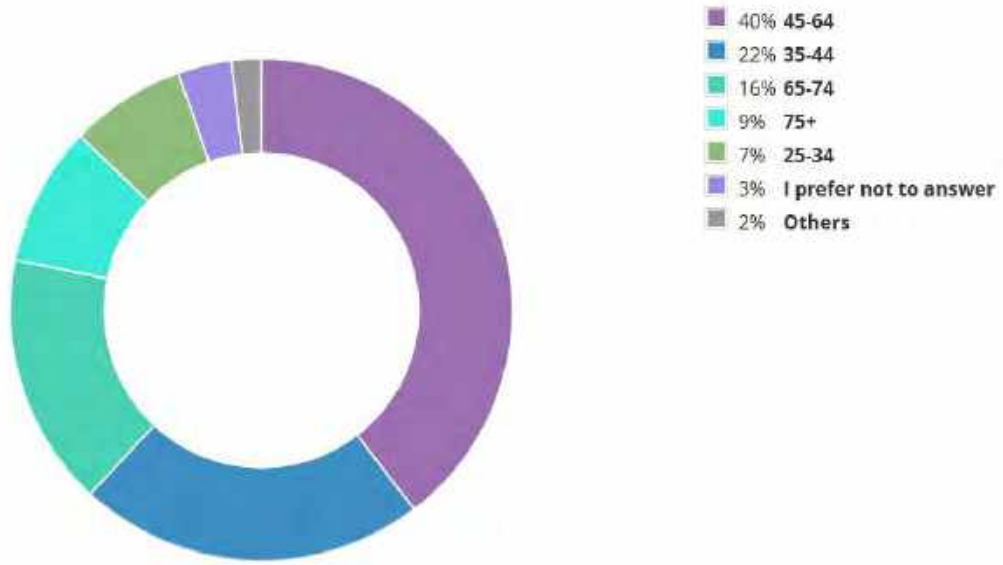

724 respondents

3. What age groups live in your household? (Check all that apply)

| | | |
|-----|---------------------------------------|-------|
| 77% | Adults | 669 ✓ |
| 27% | Children | 239 ✓ |
| 27% | Adults 65+ | 234 ✓ |
| 23% | Teenagers / tweens | 204 ✓ |
| 13% | Infants/ toddlers | 114 ✓ |
| 1% | I don't know / I prefer not to answer | 8 ✓ |

870 Respondents

4. How often do you typically use or visit these locations operated by the City of Menlo Park?

| | Never | Rarely, once a year or less | A few times a year | Once or twice a month | Once or twice a week | More than once a week |
|--|--------------|------------------------------------|---------------------------|------------------------------|-----------------------------|------------------------------|
| Afterschool programs | 74% Never | 5% Rarely, once a year or less | 5% A few times a year | 4% Once or twice a month | 5% Once or twice a week | 7% More than once a week |
| Athletic fields (soccer, baseball, etc.) | 34% Never | 15% Rarely, once a year or less | 17% A few times a year | 11% Once or twice a month | 12% Once or twice a week | 10% More than once a week |
| Community and cultural events | 18% Never | 22% Rarely, once a year or less | 45% A few times a year | 11% Once or twice a month | 3% Once or twice a week | 3% More than once a week |
| Dog park | 67% Never | 7% Rarely, once a year or less | 10% A few times a year | 6% Once or twice a month | 5% Once or twice a week | 6% More than once a week |
| Gymnasium (basketball, volleyball, etc.) | 56% Never | 17% Rarely, once a year or less | 14% A few times a year | 5% Once or twice a month | 5% Once or twice a week | 3% More than once a week |
| Meeting rooms / facility rentals | 67% Never | 21% Rarely, once a year or less | 8% A few times a year | 3% Once or twice a month | 1% Once or twice a week | 1% More than once a week |
| Parks / green spaces | 6% Never | 5% Rarely, once a year or less | 15% A few times a year | 22% Once or twice a month | 20% Once or twice a week | 32% More than once a week |
| Picnic areas | 23% Never | 22% Rarely, once a year or less | 27% A few times a year | 16% Once or twice a month | 7% Once or twice a week | 6% More than once a week |

4. How often do you typically use or visit these locations operated by the City of Menlo Park?

| | Never | Rarely, once a year or less | A few times a year | Once or twice a month | Once or twice a week | More than once a week |
|----------------------------|--------------|------------------------------------|---------------------------|------------------------------|-----------------------------|------------------------------|
| Public libraries | 12% Never | 12% Rarely, once a year or less | 22% A few times a year | 28% Once or twice a month | 16% Once or twice a week | 10% More than once a week |
| Recreation center | 37% Never | 25% Rarely, once a year or less | 19% A few times a year | 10% Once or twice a month | 4% Once or twice a week | 5% More than once a week |
| Senior programs | 80% Never | 6% Rarely, once a year or less | 5% A few times a year | 2% Once or twice a month | 2% Once or twice a week | 4% More than once a week |
| Skate park | 81% Never | 7% Rarely, once a year or less | 7% A few times a year | 3% Once or twice a month | 1% Once or twice a week | 2% More than once a week |
| Swimming pools | 40% Never | 11% Rarely, once a year or less | 15% A few times a year | 9% Once or twice a month | 8% Once or twice a week | 18% More than once a week |
| Tennis / pickleball courts | 44% Never | 7% Rarely, once a year or less | 10% A few times a year | 8% Once or twice a month | 11% Once or twice a week | 20% More than once a week |
| Walking / hiking trails | 14% Never | 8% Rarely, once a year or less | 21% A few times a year | 21% Once or twice a month | 16% Once or twice a week | 19% More than once a week |

844 respondents

Q5. How important are the following community programs and classes?

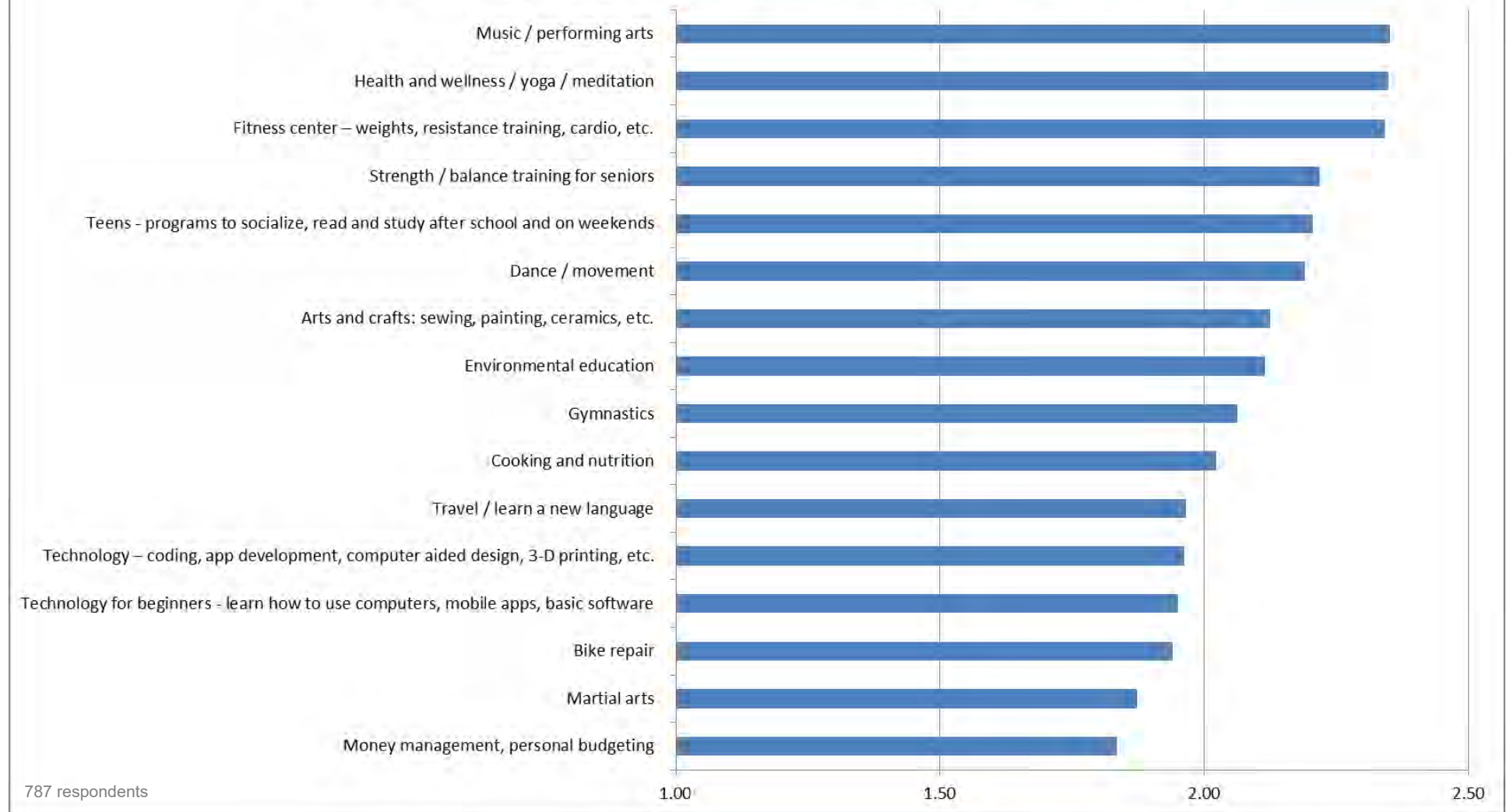

This chart shows average relative importance as rated by survey respondents. Respondents had the option to rate each item as either "not at all important," "somewhat important," or "very important." Items rated "not important" are assigned a value of 1; "somewhat important" a value of 2; and "very important" a value of 3. The chart shows the average value of all ratings for each item. Higher average ratings indicate higher relative importance to the survey respondents.

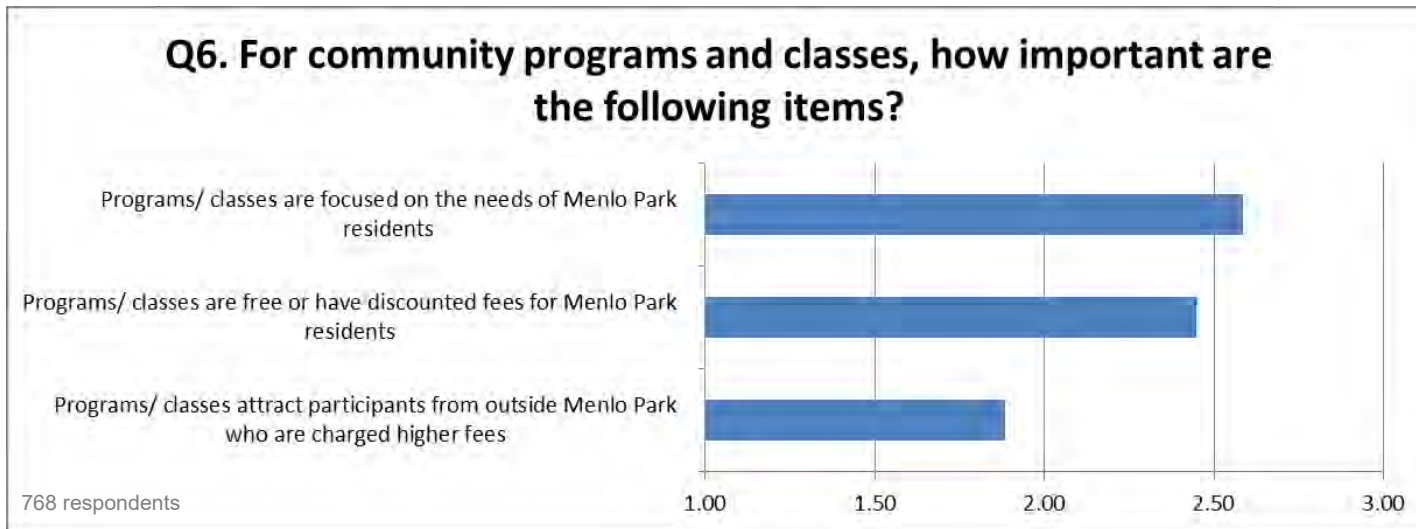

This chart shows average relative importance as rated by survey respondents. Respondents had the option to rate each item as either "not at all important," "somewhat important," or "very important." Items rated "not important" are assigned a value of 1; "somewhat important" a value of 2; and "very important" a value of 3. The chart shows the average value of all ratings for each item. Higher average ratings indicate higher relative importance to the survey respondents.

| Q7. Please tell us your ideas, needs, and suggestions for the city community programs and classes. | |
|--|--|
| 1 | Would love to have more pickleball courts available in Menlo Park. Ideally at Nealon Park, where there is a critical mass of players already using the courts. |
| 2 | It is 3 to us to have more pickleball courts in Nealon Park, they are almost always full while the tennis courts are underutilized and could be made into temporary pickleball courts while retaining one for tennis. Pickleball creates a great sense of community but also is good for our mental well being. Check out Mitchell Park in Palo Alto. Thank you. |
| 3 | My wife and I play pickleball practically everyday since August 2021 at Nealon Park. We need more pickleball courts at Nealon. Shared pickleball courts on tennis courts 3 and 4. When the tennis players leave the pickleball nets can be placed on the tennis courts. It is possible to make 4, 6 or 8 pickileball courts on tennis courts 3 and 4. Thank you for supporting pickleball in Menlo Park. |
| 4 | We need more access to a pool for regular swimming lessons and open swim. Burgess is not handling their scheduling system well. I'm hoping Onetta Harris will be better when it reopens. Getting gymnastics back would be great too. |
| 5 | WE need more pickleball courts. |
| 6 | We desperately need more pickleball courts at Nealon Park |
| 7 | We need more pickleball courts. We need to priority today ver tennis at all times, better if permanent. Pickleball UNLIKE tennis is an open community and shouldn't be places piecemeal around the city. We need a central location or two as there many discourage players who either find the courts empty due to a lack of community or over crowded courts and being turned away. |
| 8 | Pickelball has been in creasing in popularity, but Menlo Park has not kept up with enough courts to meet this demand. Tennis courts usage has been on the decline, so some tennis courts should be changed to dual usage for both tennis and pickelball. There is a tremendous amount of illegal private tennis lesson at Nealon Park. I like to see enforcement policy to ban private tennis lessons. |
| 9 | Menlo Park should offer pickleball classes for all age groups. To accomodate the explosive growth of interest in pickleball we need to increase the capacity of pickleball courts in our city, both in the very near term (e.g. converting more tennis courts for both pickleball and tennis usage) and long-term (e.g. more permanent dedicated pickleball courts). Pickleball is a very social sports that promotes the sense of community and a wonderful way for our residents physical and mental well being. ; Menlo Park should offer pickleball classes for all age groups. To accomodate the explosive growth of interest in pickleball we need to increase the capacity of pickleball courts in our city, both in the very near term (e.g. converting more tennis courts for both pickleball and tennis usage) and long-term (e.g. more permanent dedicated pickleball courts). Pickleball is a very social sports that promotes the sense of community and a wonderful way for our residents physical and mental well being. For the immediate term I believe converting 2 tennis courts in Nealon Park for dual use of pickleball and tennis is a low-cost and effective way to address the pickleball community's need immediately. |
| 10 | Classes for kids and activities as well as sports for kids 7-10 |
| 11 | Please bring gymnastics back. We have missed the classes and being able to do birthday parties there. |
| 12 | Classes for children, art, swimming, math, science etc |
| 13 | More pickleball courts! |
| 14 | Pickleball classes |
| 15 | Menlo Park gretly needs more pickleball facilities. Once more courts are available, there will be the potential for pickleball clinics which may be free or fee based. |
| 16 | All the ones listed above are great. |
| 17 | We need many more pickleball courts. The pickleball community continues to grow and attract people of all ages. Menlo Park needs to support this growing and active community now, by creating more shared tennis-pickleball courts, and in the future, by developing plans to expand more permanent pickleball courts in addition to the town's tennis courts. |
| 18 | More pickleball courts spread throughout the city. |
| 19 | Recreation classes need to include more variety. There are many dance, martial arts, and gymnastics classes, but the variety is lacking. For example, the only "art" classes now are sewing. The city has also repeatedly failed to program any classes for individuals with special needs or disabilities or insist that contracted instructors accommodate residents with disabilities. Instead of very specific classes, like drawing or sewing, what about a class that could accommodate a variety of abilities like Mixed Media, collage, non-representational art? Dance classes are very specific to type and age, what about a dance for all class that had a wider age and ability range so more could benefit? The community has identified the need for teen programming for many years but has yet to program for it. If teens don't have positive outlets, they will find not so positive ones. |
| 20 | Expanded pickleball courts such as at Nealon Park, not necessarily dedicated to pickleball but another tennis court with the dual stripng |
| 21 | Menlo Park residence really should have priority over venues and timeslots. Also, it needs to be VERY affordable. Not just "affordable" considering we're in the area of Atherton and many parts of Menlo Park. If you want Menlo Park residents, in particular Belle Haven residents, two be excited about using facilities and the services, you need to incentivize them. ; Being a Belle Haven resident, I realize I just can't afford things the way other people in the area can. Going to yoga classes was very affordable at the Onetta Harris community center. Also my sons went to karate there as well. Unfortunately the teacher passed away. And they could not find anybody else. I'm not sure if teachers get paid the same no matter which location they work at. I wanted my kids to do gymnastics but really can't afford the gymnastics at Arrillaga. |
| 22 | Would love access to swimming lessons and activities for young kids with affordable fees. |
| 23 | Gardening to feed the family ;) , raising bees and chickens |
| 24 | Adult King Fu, Kempo or defensive martial arts, gardening, home maintenance/ remodel classes, learn another language, solicit opportunities for local residents to offer classes based around their skills / hobbies |

All comments are shown as they were written and submitted by the respondents, and are numbered in the order they were received.

| Q7. Please tell us your ideas, needs, and suggestions for the city community programs and classes. | |
|--|---|
| 25 | Having access to child care if a caregivers would like to enroll to community center classes but unable to due to childcare issues Priority to those who reside in Belle Haven Affordable community center classes |
| 26 | Pool; gymnastics; sensory play; dance classes; Zumba for adults; |
| 27 | - Annual family membership to Burgess and other MP pools is needed - Do not use tennis courts as pickleball courts |
| 28 | Nursing rooms for nursing/lactating mothers. Infant care classes. Updated track and field. |
| 29 | Life skills for teens (handling finances, job interviews, education opportunities). Cooking. |
| 30 | More off leash dog access particularly on weekends. |
| 31 | Pool use more hours during the year. |
| 32 | 2 additional mixed-use pickleball / tennis courts at Nealon, more dedicated pickleball courts in the future (across MP) |
| 33 | Open the gymnastics classes for children. |
| 34 | Just want to have weight/physical exercising classes with discounts to residents |
| 35 | Pickleball is hugely popular and growing sport. We need more courts now. Conversion of two more tennis courts at Nealon to 8 pickleball courts (which can be used for tennis or pickleball) is necessary and makes great sense for our community. |
| 36 | The pool is critically important for older adults who cannot manage the dry land exercises. However, the pool has been taken over by athletes to the exclusion of ordinary families and seniors. |
| 37 | I very much enjoyed and benefitted from Aquatic Wellness for senior citizens. Feel it is 3 to offer this service to seniors as water exercises is the most beneficial and least apt to cause injury than any other programs for Seniors. |
| 38 | water wellness programs for elderly and disabled people are important |
| 39 | I used to participate (as a Palo Alto resident) in the excellent aqua wellness program at Burgess Pool, but it has not been offered in the same format, at the same times, nor as often, since the Covid shutdown. I swim occasionally and appreciate the warm pool, but have had to find a private aqua wellness program, which is much more expensive and further away. |
| 40 | I really appreciate the option to attend meetings in the library or Rec Ctr rooms where community organizations are presenting -- such as SFBBO (about local birdwatching) or topics that offer ways to more enjoy where I/we live. I am extremely disappointed at the Burgess Pool's dropping their very successful aquawellness programming in favor of more cardio-focused aqua-exercise or PT, 1:1 type of aqua exercise that are much more expensive and not as valuable to overall whole body conditioning/wellness. |
| 41 | Please, open back gymnastics. This is only one gymnastics in Menlo Park/Palo Alto/Stanford area. The classes were so convenient (there were classes for different age kids at the same time). Coaches were super friendly and absolutely kind to kids. Kids loved environment and a huge and bright room. Please, bring it back, now the closest gymnastics for kids is in 25 min drive one way and it is packed. Thank you! |
| 42 | Please let us swim in the burgess pool. I cannot afford the private pools and burgess is always too busy with the team sheepher group |
| 43 | Please reopen arillaga gymnasium and restart gymnastics! |
| 44 | Please reopen gymnastics- such a wonderful program and we can't find anything else like it |
| 45 | Menlo Park's library is a disappointment compared to other cities (eg palo alto). It would be great to see an investment into a better one Local music and art classes for toddlers are great, but often full. I'd love to see more. I'd also love to see swim classes for infants/toddlers in menlo park |
| 46 | Lastly, it would be interesting to have local block parties to meet neighbors. |
| 47 | We would really love for the gymnastics program to be restarted. |
| 48 | Aerobic exercise classes after 4 or 5 pm Monday through Friday - Open swim time for families on weekends - Group swim lessons vs. private lessons - Open access to lap swimming in the Performance pool (early morning and evening) so that people who work during the day and can't afford Masters can continue to swim - Limiting rental to other organizations at least until 2023 when the new MPCC opens - Reasonable pricing so all Menlo Park residents can swim - Menlo Park should take back ownership of the pool and end the arrangement it has with its for-profit contractor that has been crowding out public access in favor of private programming. |
| 49 | We used classes and programs heavily when the kids were younger. Now that they're tweens/teens there doesn't seem to be as much for them. Would be nice to have a free hangout space to rival downtown and Menlo Church. Some place for them to go now that quarantine is over. |

All comments are shown as they were written and submitted by the respondents, and are numbered in the order they were received.

| Q7. Please tell us your ideas, needs, and suggestions for the city community programs and classes. | |
|--|---|
| 50 | Free swimming lessons for Menlo Park residents. More open swim time for families. Reasonable pricing for swimming so families can afford to swim. Eliminate the programs we do not want. Consider public safety programs aimed at educating the community. For example, run programs on how to make (inexpensive) indoor air filters or how to use a fire extinguisher. I also do not see programs aimed at the residents living in Belle Haven. For example, start a "family time" where there is something for the whole family with entertainment for kids, enjoyable couple time for parents and even a simple dinner. I also think that MP should end it's public-private partnership with a for-profit pool operator who puts his paying students ahead of residents. |
| 51 | Having lived here almost a full year I'm not up to speed at all what the City offers in terms of programming. Would love to know more and excited to learn more to be more involved in the community for my family and kiddos. Would love to be added to an email list if one exists. Also has there been thought given to incorporating any sort of announcements (kid related) into the school newsletters? |
| 52 | Larger library budget for acquisition of both hardback and e-books. |
| 53 | City programs and classes should reflect the needs of the diversity that exists in the City of Menlo Park (more than just Dance). |
| 54 | We have two little ones and would love to see the gymnastics center open again as well as more swim and affordss as me athletic programs for their age group. |
| 55 | The dog park at Nealon is a fabulous community resource. How can it be improved or hours extended to encourage fewer off-leash dogs elsewhere? |
| 56 | We're interested in children's theater & gymnastic programs + table tennis or tai-chi for seniors |
| 57 | Aqua wellness/aqua therapy classes for seniors without class space reduced for children and lap swimmers plus taught by knowledgeable experts in that specific field. |
| 58 | My family and I really love Menlo Park and feel very safe in it, but there are a lot of things to be done, a free gym or athletic center for the community, outdoor events and celebrations for the whole community, gatherings, bbq, 4th of July is coming up so there should be something for everyone in Menlo Park to gather and celebrate |
| 59 | The gymnastics program should reopen. |
| 60 | My children participated for many years in the gymnastics program, and we were incredibly grateful for it. The instructors were generally very good, and my children thoroughly enjoyed the classes beginning with mommy and me classes and ending with competitive team participation. The gymnastics program, in my opinion, is a highly valuable program offered by the city. |
| 61 | BRING BACK GYMNASTICS FOR TODDLERS AND PRESCHOOLERS. It's crazy to me that Menlo Park has yet to bring back this program and found a way to adapt during the pandemic. We have instead used more community resources from Palo Alto. Much more impressed with their community resources. |
| 62 | Please begin hosting summer concert and activities again! |
| 63 | There is a park on willow oaks that has 3 tennis courts it will be great if one of them is converted to 2 pickleball courts. That will engage more people to come |
| 64 | Please bring back gymnastics! HUGE gaping hole in Menlo Park right now!! :(|
| 65 | Please open the gym for the kids! It's world class facility and it's just sitting there unused. What a waste. There's no reason why it's not open when everything else is open. |
| 66 | The aquatic exercise classes, taught by Sheralee Beebe, are valuable to people who have disabilities or whose advanced age makes other kinds of exercise impractical. I attended the classes at Burgess pool for two years before the COVID-19 pandemic hit. The program in Menlo Park is still not available for me, so I go to aqua fitness classes in the Palo Alto YMCA. |
| 67 | Bring back gymnastics! |
| 68 | More outdoor programs eg. Storytime at the library can be in the courtyard instead of indoors. Outdoor dance/martial art classes etc. |
| 69 | Tennis courts have been impacted by pickleball. Any expansion of pickleball courts should not be at the expense of tennis. |
| 70 | I worry that when my 7 yo is a tween/teen he will have nowhere to go and hang out with friends if he's not on a sports team or wants to hang at the skatepark. Why not take some of the vacant space on Santa Cruz Ave and turn it in to a STEAM hangout for kids with a juice bar, music space etc...like a modern teen center. Older kids could work there and be paid too. There could also be an area for bike repair. So many kids bike to Hillview. Kids need constructive places to gather. And what about programs for kids that take them outside the city on a hike, whitewater rafting, fishing etc.. |
| 71 | I'd like to understand what outside groups are using the fitness facilities (Ariaga gym, pool) so that I can use the facilities through their programming if the city programming doesn't fit my schedule. A good example is the early morning fitness at the gym. I don't see that listed on the class list but I see all sorts of groups when I run past the gym in the morning. |
| 72 | Warm water (92+ degrees) aquatic therapy pools, handicap accessible. |
| 73 | I was an avid attendee to the former Aqua Wellness Program for years. We had an excellent teacher who kept us moving forward even though we were aging! The present programs are geared to the younger population with focus on intense cardio movements. The new program led by a physical therapist has its place, but should NOT be considered a replacement for Aqua Wellness. If we need that intense of a program we would be attending, but we are not severe yet nor can we afford it on a fixed income. |
| 74 | We are in need of additional pickleball courts at Nealon. The pickleball courts are packed while the tennis courts are empty |
| 75 | Sharee was very helpful to me when I needed aquatic rehab. |
| 76 | Create more pickleball courts to establish a community feel for Menlo Park. Allow more hours for pickleball (as opposed to tennis) to allow for pickleball programs and classes/clinics. |
| 77 | It would be nice to have facilities for cooking classes at the recreation center. Running, biking, hiking groups would be nice. And maybe other group activities - like surfing, paddle boarding, rafting |
| 78 | Everyone in my family cannot wait for the kids gymnastics program to restart. I would utilize Spanish classes and think it would benefit a lot of community members (or if not a class, then a meet up with people to talk in English/Spanish and be mutually beneficial) |

All comments are shown as they were written and submitted by the respondents, and are numbered in the order they were received.

| Q7. Please tell us your ideas, needs, and suggestions for the city community programs and classes. | |
|--|--|
| | - Arrangement for Belle Haven families to have access to swimming during the 3-year closure of their neighborhood pool. - Open swim time for families on weekends - Group swim lessons vs. private lessons - Open access to lap swimming in the Performance pool (early morning and evening) so that people who work during the day and can't afford Masters can continue to swim - Limiting rental to other organizations at least until 2023 when the new MPCC opens - Reasonable pricing so all Menlo Park residents can swim - Menlo Park should take back ownership of the pool and end the arrangement it has with its for-profit contractor that has been crowding out public access in favor of private programming. |
| 79 | |
| 80 | Two public run swimming pools at more affordable rates for residents as we used to have |
| 81 | Don't let third-party providers run the programs primarily for their benefit; focus on serving Menlo Park residents. Fee differentials for residents and non-residents should be substantial (like, double for non-residents) |
| 82 | I'd love to see a ceramics class where you can use a pottery wheel. There aren't many around here, whereas you can often find other programming, like music, at other places. |
| 83 | 3 that Tim Sheeper/Menlo Swim continues into the future managing the swimming pool and it's programs. He and his staff do an outstanding job not only on maintenance but providing a variety of programs servicing all ages and skill levels |
| 84 | More fitness classes, more arts and crafts |
| 85 | Pool exercises in water shallow enough to touch shoulders for walking and stationary exercises. More senior exercises. |
| 86 | To include nearby East Palo Alto residents |
| | Upon moving here I was surprised by how few classes are offered via parks and rec, and how few community events there are. There should be a wide variety of classes for kids, adults and seniors. These classes can be run by different community organizations, companies and individuals. San Carlos and Redwood City have a much wider variety of classes than Menlo Park -- as well as wonderful community events -- and would be good cities to emulate. |
| 87 | Please also bring back musical performances and other arts performances. |
| 88 | Being a family with small children, we would be excited for programs geared towards families & children. |
| 89 | I'd love to see the entire gymnastics program for kids open up again. It's a huge bummer we don't have it in Menlo and residents need to travel to RWC or Sunnyvale to get them. |
| 90 | Appreciate all fitness classes for adults; also tech classes. I'd like to see classes on using iPhone for photography and video - for beginners. |
| 91 | would like a well-thought out informed strategy for pickle ball courts, which are used by people from as far away as San Jose. |
| 92 | make pool more accessible to the whole community-private lessons are given preference when this is a community pool; get the gymnastics program back. this was a very valuable program for our kids and I talk with many parents who want it for their kids |
| 93 | We NEED more pickleball courts. I don't know how many years have to go by to get something done. The courts we have now are always busy and the nets are falling apart. Please add more courts, the tennis courts are rarely used.; I am filling out this survey because the community needs more pickleball courts. thank you.; Nealon Park has only four courts and the tennis courts right next to the pickle ball courts are, most of the time, unused. |
| 94 | More Pickleball courts! Nealon Courts have had the most positive neighborhood impact of anything we've experienced yet! |
| 95 | Increase Pickleball Courts! |
| 96 | Pickleball becoming very popular. Courts are important. |
| 97 | Permanent Pickleball courts are needed. |
| 98 | Dedicated pickleball courts and more dual tennis/pickleball courts, especially at Nealon Park |
| 99 | My passion is pickleball. Earlier this year I used to play it 1x or 2x a wk at Nealon Park but I got discouraged by the crowds there. We need more pickleball courts in Menlo Park. Thank you!! |
| 100 | I love the way pickle ball brings together people of all ages. If we could have more pickle ball courts that would be great. |
| 101 | I believe pickleball is the fastest growing sport, it's quick to learn, inclusive and very social. Each city should have courts. |
| 102 | would like more pickleball courts |
| | Low Burgess but dressing and shower frailties for women are way too small for all the users. Actually need deprecate pool for lessons, summer camps and classes, the pool gets so much more use than any other piece of the open park area, baseball fields etc. More pickle ball courts Class times are geared to working people as they are scheduled in the early morning, lunch and evening, nothing for seniors mid morning or afternoon. We don't want evening classes. What about a servie that matches seniors to volunteering to assist with classes, camps etc, not just the senior center. |
| 103 | |
| 104 | Guitar classes! |
| 105 | There is an increase of older people to play sports such as pickleball. We need more courts available. Thank you |
| 106 | Pickleball classes for all ages |
| 107 | I would like to see more Pickleball Courts. The Tennis Courts are often empty, but people are waiting to use the four Pickleball Courts in Nealon Park. The nets in the Pickleball Courts at Kelly Park are in need of repair or replacement. |
| 108 | We need more permanent pickleball courts. I play 4 to 5 times a week and am forced to go to neighboring courts as Menlo Park does not have enough. |

All comments are shown as they were written and submitted by the respondents, and are numbered in the order they were received.

| Q7. Please tell us your ideas, needs, and suggestions for the city community programs and classes. | |
|--|---|
| 109 | I'd love pickleball classes |
| 110 | Keep the name of Onetta Harris for Belle Haven new Center on Terminal |
| 111 | regular in-person teens socializing programs, inclusive programs (especially of people with disabilities), lower-cost recreation programs for toddlers, children, and teens in Menlo Park, sibling discounts |
| 112 | Pickleball classes. |
| 113 | Bring back the gymnastics program for young kids. I've heard great things and my daughter has been waiting to try it. Green spaces are important, especially with shade. |
| 114 | Swimming/improvement lessons for adults. |
| 115 | You're doing a great job - thank you. |
| 116 | I'd love to see more big community gatherings. Movie nights, music in the park, art festivals downtown, maker spaces at the library. |
| 117 | There is a need for an open gyms at both community centers with equipment for exercise & low fees for usage. |
| 118 | Expand and improve pickleball courts. |
| 119 | This past school year, i wished that there were more swimming lesson options during after school hours. Now, i understand the swim team that meets at Burgess has a lengthy waitlist? If there were an option to expand via staff (if it isn't a facility capacity issue), that could be worth attention! We have also been waiting, along with many other kids' families, for the excellent gymnastics program to come back! Thanks! |
| 120 | Would liee to see the grassy areas open during the summer and fall months. At this time they are fenced off for reseeding. |
| 121 | Art studio classes |
| 122 | Cafe at the library |
| 123 | I would love to see the gymnastics for toddlers to come back. We've never been able to use this resource and I heard it was amazing |
| 124 | Remember that the parks belong to the residents of Menlo Park and not just organized soccer groups. The parks seem to be surrounded by orange mesh most of the year for restoration. Local residents who like to play in the park, visit with neighbors, walk their dogs, etc., can't use the parks most of the year. As for community classes, there are many low income residents who can't afford to take classes. Making the classes more affordable would be great. Also, don't forget about the adults and seniors. Seems most classes are geared towards children. Remember the tax payers. |
| 125 | Downtown fairs and events are always wonderful. Would be great if there were movies in the park (like in Redwood City) and more summer activities for families and all ages. |
| 126 | We want gymnastics back, kids enjoy that pre pandemic, now when everything is open it still has been closed. That's frustrating. |
| 127 | I'd like a makers space with tools |
| 128 | More events at the libraries or rec centers for babies/toddlers. |
| 129 | Continue providing services and get services that were closed due to COVID back up and running like the gymnasium. |
| 130 | Continue to support Menlo Swim and Sport programs |
| 131 | I can't speak to how important these classes are. They all seem to be important. Are people taking them? I'm sure that will be evaluated. |
| 132 | Please add more options for pickleball use. It is a wonderful way to bring all facets of the community together. |
| 133 | The city should endeavor to enable and seek out local Menlo Park contractors for resident programs. The city should work in conjunction with the school district, to organize a competitive sports environment for kids in school by hosting city championships in various disciplines as well as hosting city events for adults. Too much favor is given to outside contractors from other cities who are not invested in our local community. |
| 134 | More Pickleball courts and activities and communication, like Foster City and Palo Alto do. |
| 135 | Please reopen the gymnastics center |
| 136 | pickleball classes |
| 137 | I would like to request the permanent conversion of courts #3 and #4 to pickleball in addition to court #5 being kept for dual usage |
| 138 | I hope we can have group swimming lessons for children again. We can't afford privates. And can we please reopen the gym (gymnastics programs)? That was a treasure. The loss of swimming lessons and gymnastics because of covid has very much impacted our family and other parents in our community. Covid restrictions seem to have made the public space less accessible in general to families who are not wealthy enough to hire private teachers for everything. Please re-open if possible. Thank you!! |
| 139 | new in the area so i say the library is the perfect place to meet new people and know more about the area |
| 140 | Pickleball classes for new players. Many of us got introduction to pickleball from the Palo Alto City classes. Also, Intermediate classes for pickleball. |
| 141 | I have older kids that no longer live at home. I have never been impressed with Menlo Park's programs. We've typically driven around (when kids were younger) to do other programs outside of Menlo Park. I have recently started playing Pickle Ball at Nealon Park. Would LOVE to see some more tennis courts get converted as the PB courts more busy than Tennis. |
| 142 | We hope to have a big pickleball court . So people do not need to go to Palo Alto playing everyday |
| 143 | Love to have more pickleball court space |
| 144 | We need more pickleball courts vs tennis courts. One of the fastest growing sports in America and certainly on the peninsula. |
| 145 | More pickleball courts. They are full many hours a day! High school students thought senior citizens! |
| 146 | More pickle ball courts |

All comments are shown as they were written and submitted by the respondents, and are numbered in the order they were received.

| Q7. Please tell us your ideas, needs, and suggestions for the city community programs and classes. | |
|--|---|
| 147 | More pickle ball courts |
| 148 | More pickle ball courts |
| 149 | summer programs that are reasonably priced for kids, e.g., coding, gymnastics, swimming, acting. |
| 150 | Tener clases de inglés y que nos ofrezcan cuidado de niños al momento de asistir a clases |
| 151 | Exercise classes, physical fitness, gardening, discussion groups keep me thriving. Any possibility of a community garden in Menlo Park? It may interest folks who may wish to expand gardening opportunities beyond small patio container options. Thank you for the nice maintenance of the duck pond and park in Sharon Heights - it's my go to place for walking and relaxation. |
| 152 | Como cuidar el medio ambiente, usar material reciclado para otras actividades y minimizar la cantidad de plásticos en el planeta, como mantener limpia la ciudad, hacer campañas de limpieza por lo menos cada 3 ó 4 meses al año. |
| 153 | We enjoy live music at Fremont Park. PLEASE consider a complete, weekly schedule of music in the future. The pandemic has clearly impacted city events, but the live music draws residents of all ages and brings the community together in a safe way. This is the best way for us to get outside and enjoy the downtown restaurants. Thank you. |
| 154 | More community events. Look at Los Altos. They do an amazing job!!! |
| 155 | I've lived in four different neighborhoods of Menlo Park over the past 40 years. When my daughter was young, she enjoyed the dance and gymnastics programs for children. I participated in exercise programs for many years until an injury made it difficult. I love MP library and am often frustrated by the variable hours of operation- especially when the library was no longer open after my morning exercise class. I walk daily and find the lack of sidewalks not only frustrating but downright dangerous. The bumpy yellow patches at intersections may help some, but are a trip hazard for others of us. I wish we had more unpaved walking paths which are much easier than concrete on aging joints. |
| 156 | I walk the dirt path by the RR tracks on Alma almost daily because walking on concrete is dangerous for my feet prone to plantar fasciitis. I wish we had dirt walking paths where the trains didn't blow past. But it is lovely walk under the trees by the RR tracks. Off-topic: I saw a lady with grandson feeding the ducks -- right by the DO NOT FEED DUCKS sign. She couldn't read English but was very happy to learn what the sign says. You need that sign in several languages if you really want the ducks treated right. |
| 157 | Please re-open the gymnastics center or rent it out to those who can provide classes. |
| 158 | Pickleball classes |
| 159 | Cooking classes or demonstrations |
| 159 | Please open the gym. Also should prioritize Menlo park residents need and benefit first. |
| 160 | Please make the swimming classes more affordable for children who live in Menlo Park. |
| 161 | Please reopen gymnastics |
| 162 | Improve Access to Pickleball . more courts.. more hours.. and please cut the lock on the gate at the Pickleball court. It is a fire hazard / earthquake hazard to LOCK people in with only one way out. Be smart about this. |
| 163 | Would like to have ballet/dance/gymnastics classes for toddler or young children. |
| 164 | Please continue to invest in the Belle Haven community. |
| 165 | More dedicated pickleball courts |
| 166 | Release more pickle ball courts in Menlo Park |
| 167 | need a bench to sit on between games at Nealon Park Pickleball courts. |
| 168 | Community gardens. Outdoor festivals. |
| 169 | -Provide culturally relevant activities and programming. -Offer comprehensive services to the Belle Haven area. -Provide free/affordable service/programming to low-income residents. |
| 170 | Teens have very little to do in MP or the surrounding area. They tend to like to hang out in the evening and there is just nothing for them. In addition, Menlo Park is one city, not East and West, so ensuring equity of services is paramount. |
| 171 | More pickleball courts! |
| 172 | suggest to add more pickleball courts at Nealon park |
| 173 | More pickleball courts. How many pickleball courts can fit on a soccer field? Pickleball uses far less land, doesn't need water, pesticide, herbicide (although could be more green-friendly), used by ALL ages including families. |
| 174 | I think all of these are extremely important for the community and would be inclined to pay for/attend if available. ; I'd love to see free swim lessons for communities who need them. |
| 175 | Open the gymnasium which has been closed for 2+ years and run it at the same high level as the Burgess pool. |
| 176 | Please do not consider closing pool or changing current management. Many people know what the pool was like before Sheeper was running it. Swimming pools and programs are vital to a healthy community. Integrity will triumph. |
| 177 | We need to make MPO a more vibrant community - current programs except for those at Burgess are not good enough. And Why is the Arillaga Gym still closed?? oi kids cannot get access to gymnastics |
| 178 | More availability for community use of pool |
| 179 | Parents of young kids (2-5) need local options for gymnastics, soccer, and ballet. |
| 180 | pok' |
| 181 | Different martial arts, flag football, hi-5 sports programs, more swimming lessons |
| 182 | We have been waiting for the Gymnastics program to start up again. The only other gymnastics program in the area (in redwood city) is very full with long waitlists. It's so convenient to have gymnastics through Menlo Park and it's unfortunate that it hasn't opened back up yet. |

All comments are shown as they were written and submitted by the respondents, and are numbered in the order they were received.

| Q7. Please tell us your ideas, needs, and suggestions for the city community programs and classes. | |
|--|--|
| 183 | It seems like compared to neighboring cities, Menlo Park classes, services and events have not come back or take much longer, even outdoor options, which has been disappointing. I have a 5 year old and after living here for a decade, it now seems like he may age out of the ability to take advantage of the gymnastics offerings, which also have not come back. Local parent and neighbor Facebook groups complain about this often. |
| 184 | We would highly appreciate an inclusion program that can support inclusion of children with special needs in the Menlo Park after school and camp programs (similarly to the assistance they get at school) |
| 185 | Kids gymnastics |
| 186 | I'd like to suggest that the City Council, if they have not yet, survey other municipalities in San Mateo County, and see how other aquatics programs serve the needs of the community. My guess is that "the squeaky wheels are getting grease" in the current situation at Burgess. Residents who are happy with the programming are not so likely to let you know as those who have complaints. I was an aquatics professional for 30 years. I have done the work that Tim Scheeper is doing and I can tell you that there are few programs in the country that provide such diverse programming and give opportunity to so many people. It's not an easy job and certainly more difficult when the support of the municipality is not behind you. I strongly urge the city council to look on the bright side of what is being offered to the community. Having been the professional who was squeezed out of space by those "squeaky wheels" myself, I can comment that it is likely those people who are complaining will probably not attend often anyway and those who are being disenfranchised will lose their opportunity. The pool would sit empty is my guess. Water is a precious resource. Better to have the pool occupied and scheduled for activity rather than giving those who MIGHT show up more opportunity. The team at Burgess knows how to maximize the space and time. Even those squeaky wheels have time allowed for their use though they may not choose to go when the time is available. I would love it if my swim practice was at 10AM. I retired now and it would be my best choice. But I go when the time is scheduled for the programing I participate in. Seniors, families and disabled should do the same. That way everyone has equal opportunity.; Team Scheeper is doing a Jam up job!! |
| 187 | Dance classes, chuldren's arts and sport classes, music concerts |
| 188 | We have been desperately waiting for kids programs and gymnastics to come back |
| 189 | More space in children's sports activities, they're always waitlisted. More slots in swim classes, we've been trying to get in for over a year. Maker space for other creative training. |
| 190 | Options for mothers to get together with young babies or kids! |
| 191 | We would love to see gymnastics reopen and the pool continue to be use for recreation, camps, and swim teams. |
| 192 | First aid for all ages |
| 193 | It's time to count unincorporated Menlo residents as residents. It is the biggest factor in my family avoiding classes and the pool. |
| 194 | The gymnastics program at Burgess hasn't been running since Covid began and it's time to bring it back. The facility is sitting empty, when hundreds of local children should be using it. It is ridiculous that the gymnastics program hasn't been reinstated. |
| 195 | These programs need to be restored to pre covid levels it is really a problem, when nothing is done for over a year or more once county restrictions were lifted. |
| 196 | Outside Zumba. Park exercise where you can show up. I've done this in other communities. Group to meet people. |
| 197 | more variety classes for adults (non-seniors) that isn't just dancing (art classes would be amazing!), and a real gym where residents can freely use weights, equipment, etc. |
| 198 | Love the new pickleball courts at the Nealon Park, amazing addition for our family. Please keep them! Would like to see more soccer fields for youth soccer and would like a better /larger swimming pool for families. It is dominated by lessons and crowded, would be great to have a larger one or more options to swim in Menlo Park. |
| 199 | walking clubs |
| 200 | We need the pool to stay open :) I'm also not sure if the survey is asking how important things are *to me* (and my family) or how important I think they are to the general community. Those are two different answers for many of the questions. For instance, below on the swimming question - my kids are out of swim lessons so they are not important *to me* but are 3 to the Menlo Park community and I support them. I'm filling out the survey assuming that the questions are asking how important things are to the wider MP community, not just to my personal wants/experiences. For our family, there are enough private groups offering things like singing lessons and soccer and martial arts that we haven't looked to the city to meet those needs. |
| 201 | We took years of lessons at Burgess and now have two kids in swim team there and I reguarlarly swim laps. |
| 202 | Need more wellness and arts programs for seniors and teenagers. |
| 203 | Develop a park at SGI! Lots of people walk more now post- pandemic, and many got dogs. Pickleball is blowing up. This should absolutely be included in the Flood Park renovation!! Gymnastics at Burgess needs to be scaled way way up once it reopens. There is so much pent up demand for our little ones that have never had a chance to do it with COVID's impact. We can't even get ON a waitlist, local classes are SO full. Did I mention pickleball yet????? :) |
| 204 | I regularly attended adult gymnastics and Circus Aerials years ago, and would like to see this return. It would be great to see Menlo Park consider adding a disc golf course to one of its vacant green spaces. |
| 205 | It would be nice to bring back the gymnastic program. It was such an amazing program for the kids. |
| 206 | None |

All comments are shown as they were written and submitted by the respondents, and are numbered in the order they were received.

| Q7. Please tell us your ideas, needs, and suggestions for the city community programs and classes. | |
|--|--|
| 207 | Tim Sheeper has dramatically benefited Burgess and the entire MP swim program and community. All ages, all levels of athleticism. He took it from an under used program that was failing economically to a profitable Program so heavily used that people complain that they are comparatively under served. The problem now is too much success and popularity and the call for more services. Tim's success should be supplemented rather than punished. |
| 208 | I use the Burgess Park Pool and have for many years. My children participated in swim lessons, swim team and swim camp there. I value the Burgess Park Pool as an important aquatic resource on the peninsula. The Burgess Park pool is exceptionally well run with a wide range of programming for youth through seniors. The pool area is clean and safe, the staff is friendly and well trained, the availability of lap lanes is good. Many people depend on this resource for health, fitness and children's water safety |
| 209 | I would like to see more computer skills classes. |
| 210 | We raised our kids taking swimming lessons from age five, Menlo Maverick's, swim team, Camp Menlo summer camp, aerial silks, fun free swimming, lap swimming, and masters swimming for the past 12 years. |
| 211 | I formerly lived in Menlo Park for over ten years and then joined the Menlo Masters Program. I have swum with Menlo Masters for over 13 years and dearly love the program and want it desperately to continue. |
| 212 | All programs are essential to keeping Menlo Park an outstanding community . Reduced fees for residents is critical. Non profit organizations that can increase access to programs for underserved communities of Menlo Park should continue to be utilized. |
| 213 | The circus program at the gymnastics center is the most important and the one that is most important to our family and the most unique to Menlo (aka attracts people from the outside). |
| 214 | More pickle all courts, please. Also, a dog park for smaller dogs. |
| 215 | We need gymnastics open for our kids, Burgess playground it looking a little shabby lately, the library hours need to be extend to open earlier, more classes for toddlers |
| 216 | Guided walks, gatherings where people can work on crafts together (not teaching, just doing), a way to link language learners together (i.e. I am learning Spanish with Duolingo, but would like to meet someone my age to chat with and improve my understanding and fluency) |
| 217 | PLEASE PLEASE We would LOVE to see the Arriaga Gymnastics class for toddlers/childrens come back. |
| 218 | We need a beautiful dog park. With grass and large expanses to run and play. The Willows dog park is subpar. If the field next to the school were available the community would come out far more than they do now. I would venture that more than half of the non-dpg households have gotten a dog in the last two years. This needs to be vastly improved. |
| 219 | I don't participate in many community programs anymore but I do think they are 3 for the community. I would also like to see more mixed age programs, for instance Dungeons and Dragons, for seniors/adults/teens, and not just offering programs to the age group we conventionally associate with that activity. I also think the community will benefit from interacting with all ages and not conforming to agist stereotypes. |
| 220 | recreational gymnastics, working (repaired) playgrounds, classes for special needs, classes, support and open space for home schoolers. |
| 221 | please bring back softball, widen basketball appeal |
| 222 | There are dozens of new residents in BH and we all meet while walking dogs and our dogs want and need and deserve a good dog park to play in!!! |
| 223 | My fear is that people of color may not feel welcome because our community has changed so much. There must be a way to help long term residence to feel that it is still our community. |
| 224 | Classes for all, students, seniors, adults, families, children of all ages |
| 225 | Free classes for residents |
| 226 | Belle Haven--Senior \$ management classes, low income housing education, pet laws + county licensing opportunities brought to community, golf |
| 227 | Beginning hula and Hawaiian huna healing (ho'oponopono) |
| 228 | Bring back the gymnastics program, PLEASE! It was awesome and the kids all loved it. Even my 8 year old keeps asking for it. |
| 229 | It is very sad that playing tennis is so expensive in our city. |
| 230 | Kids love soccer Toddler/young kid tennis |
| 231 | More community-building events, like Redwood City does |
| 232 | Love to have more cooking classes like cheese making! (Cheese making will be a huge hit at Menlo Park) |
| 233 | I would appreciate more Pickleball courts. It's both social and exercising in one. It's so easy on the body, playing on smaller courts using a wiffle ball - Very good for the soul. Everyone should do it, but there are so few courts. |
| 234 | More pickleball courts |
| 235 | Please install more permanent pickle ball courts! Thank you for being willing to get community feedback |
| 236 | more pickleball courts are needed as the demanded continues to rise! |
| 237 | Creative classes for seniors |
| 238 | More pickleball courts |
| 239 | Would like to see more pickleball courts available |
| 240 | Beginning pickleball should be taught. Clad would fill quickly. Also intermediate PB |
| 241 | More pickleball courts, please! |
| 242 | More pickleball courts it's good for all ages and it brings the community together. It is a growing sport. It benefits health. We are a member of the Palo Alto pickleball club which has over 700 members. Othe communities are having more pickleball courts. The courts could be used for tennis as well as pickleball. There are people that play both. Thank you |
| 243 | Pickleball. Needs more courts. It fits all ages. Community builder. Terrific future |

All comments are shown as they were written and submitted by the respondents, and are numbered in the order they were received.

| Q7. Please tell us your ideas, needs, and suggestions for the city community programs and classes. | |
|--|---|
| 244 | Add more pickleball courts. Give lessons for residents/non-residents. |
| 245 | More pickleball courts, please. |
| 246 | I play pickleball everyday |
| 247 | Contract the pool and gymnastics- do not run in house |
| 248 | More senior programs in the afternoon. |
| 249 | Sewing (beyond beginner), toddler gym |
| 250 | More dog parks and pickleball courts! |
| 251 | no idea |
| 252 | We need more pickleball courts please. They are used by so many all the time and bring together 6yr olds to 86yr olds 😊 it is good clean fun which brings so much joy to so many |
| 253 | It would be great to have more robust Pickleball offerings! |
| 254 | More pickleball courts! |
| 255 | It would nice to have Spanish speaking lessons available in Menlo Park. |
| 256 | I would like some pickle ball courts on the west side of MENLO Park, Closer to my neighborhood. |
| 257 | more flat areas |
| 258 | Culture exchange. Mental Health. Family relationship building. Arts & Music. STEAM. |
| 259 | I know Palo Alto has priority for MP residents when enrolling in classes hopefully MP can implement something similar. |
| 260 | We need to get the pool with more activities for kids and after school sports. |
| 261 | I don't hear much for free courses or at least pay for a class such as art, dance, or any other that is given on weekends. Also would be helpful to have on hand a magazine with all activities. |
| 262 | More recreational facilities for classes on dancing, pottery, art & crafts |
| 263 | Please bring back all the dance and sport activities for children |
| 264 | Table tennis, badminton, dance classes |
| 265 | Belle Haven needs same access and perks as the West Side MP. S |
| 266 | -Blinking lights at crosswalks! -More local art! If not murals, an opportune place for people to show-case! -A better wide-spread newsletter. It's hard for Belle Haven residents to know about events. |
| 267 | Thai Chi for seniors |
| 268 | Que nos den clases a los adultos. Gracias |
| 269 | community college campus |
| 270 | Have more activities for kids, After School Programs. Wood shop, music classes, basketball, etc. Need supervision. Have the suggestion what they like and want to do. |
| 271 | More daytime dance classes for adults such as Zumba, hip hop, jazzercise etc. |
| 272 | My husband works at Bay Club so we are fortunate to have our fitness + some community needs met there. |
| 273 | toddler gymnastics classes |
| 274 | It would be great to have a free fitness center. |
| 275 | We should honor the diversity in our community by having community gatherings in the community center for all; We should use this new center for everyone in our community instead of allowing outsiders to rent or use or fields for sports Bellhaven residence should have priority |
| 276 | I would like to see a variety of equity & inclusive involvement of Black people and programs throughout Menlo Park. |
| 277 | Please make the charge to use the swimming pools very low for residents. I don't use the pools because the fees are to high. Lessons for the kids in Belle Haven should be free! It saves lives. |
| 278 | Gardening, growing vegetables, fruits, etc |
| 279 | I was not fully fully aware of availability and other details of classes |
| 280 | More green space, outdoor play, gymnasiums, pools |
| 281 | Still don't feel that safe w/ covid doing indoor clases - outdoor yoga? zoom classes? more language and art offering, how about a menlo service orientation class? |
| 282 | Aqua swim programs core classes |
| 283 | maybe community cookouts/bbq to meet residents. Community garage sales. More free or discounted things to bring the community together. |
| 284 | It's 3 to offer similar classes that are held at West Menlo Park. It's also important that rates remain similar to Onetta Harris prices. Affordable for the community that live in Eastern MP. |
| 285 | Plaza should be nice. Shopping outlets. Malls |
| 286 | I'd love to have pickleball courts in the parks! |
| 287 | Maintain green areas and mature trees, particularly natural spaces (of which MP has very little), don't replace them with built environment, including hard surfaces or plastic coverings. |
| 288 | food preservation classes, local history/culture, welding and metal crafts, and acting/theater |
| 289 | hindi class for children, kid's soccer program, kids swimming classes |
| 290 | very excited for new kelly park construction to be finished! maybe a little more information at track about what's to come! |
| 291 | I'D LOVE TO LEARN AND PLAY PICKLEBALL! WHAT I HEAR IS THERE ARE VERY FEW COURTS AND THEY ARE VERY BUSY. ALSO, I'D LIKE TO FIND INSTRUCTION . MANY PEOPLE I TALK TO ARE INTERESTED IN LEARNING AND PARTICIPATING IN THIS ACTIVITY. |
| 292 | Pottery open studio please |

All comments are shown as they were written and submitted by the respondents, and are numbered in the order they were received.

| Q7. Please tell us your ideas, needs, and suggestions for the city community programs and classes. | |
|--|---|
| 293 | estate planning education |
| 294 | It is 3. You did a good job for the city community programs and classes. It is 3 to me. |
| 295 | English classes |
| 296 | English classes |
| 297 | cheaper housing for seniors |
| 298 | We only recently moved to Menlo Park from San Mateo. San Mateo had a great parks and rec program for taking classes for the kids. Would love to have recreation soccer, baseball, basketball, tennis and swimming opportunities available for the kids (5.5 and 8 years old). The kids go to school in a different town, and would be a great way for them to meet other kids in the community. |
| 299 | affordable classes for youth/adults. More times for working parents |
| 300 | Terapia de arte Clases de natacion para adultos clases de yerrios |
| 301 | N/A |
| 302 | No es buena idea que trabajen o ayuden mimberos de la misma familia |
| 303 | Que tengamos lases para las personas, que no sabemos leer, y unas clases para las personas de la tercera edad que no sabemos escribir y que respete. |
| 304 | I would like to see more library program for teens, especially ones focused on arts, crafts, etc. Also, please start offering classes for teens from Academy of Design: https://www.academyofdesignsf.com/ . |
| 305 | When will the gymnastics for kids restart? This was great! |
| 306 | Please do even more to support tweens/teens with free or heavily subsidized activities they can do on Fri/Sat evenings. Board game night, D&D night, etc. I am willing to help with this so please reach out to me if you want help! |
| 307 | Due to covid, I think things have to be offered online. A lot of people that are older are also still working so it would be great to have classes outside of typical work hours. |
| 308 | Para mi todo lo que enseñan me gusta los niños aprenden un poco de todo cada día |
| 309 | no tengo comentarios |
| 310 | Currently just have lack of information about community events. Belmont mails out notices or packet explaining offerings for the season. |
| 311 | Would love to have more info on these programs more accessible to the community. It would be nice to get a letter/email sent w/ all upcoming activities/classes for the month/year! |
| 312 | Exercise classes for after work hours. Many classes are during the day when I'm at work. Would love to participate if there were evening and weekend scheduled classes. |
| 313 | Create useful programs that are needed for young children and adults. |
| 314 | Having educational for the youth & teens. Job skill programs & training |
| 315 | Would love to see a rec center with a heated pool for elderly to do walking. And as much free for those of us living < the poverty line. |
| 316 | Offer digital classes, certifications would also be great to use towards resume |
| 317 | Children's & teens activities would be great for the community. Senior also but most may not be able to get there |
| 318 | I would love for there to be programs to create social spaces for parents with young children. For new parents especially this can be a nice way to build community with other folks in a similar life stage. Seattle, Washington has a program like this and it is very highly regarded. Perhaps Menlo Park can facilitate these social connections? It wouldn't require many city resources to implement, except for some administrative support. |
| 319 | Programs for small kids (under 2) |
| 320 | More civic centerswith affordable prices for the commy. |

All comments are shown as they were written and submitted by the respondents, and are numbered in the order they were received.

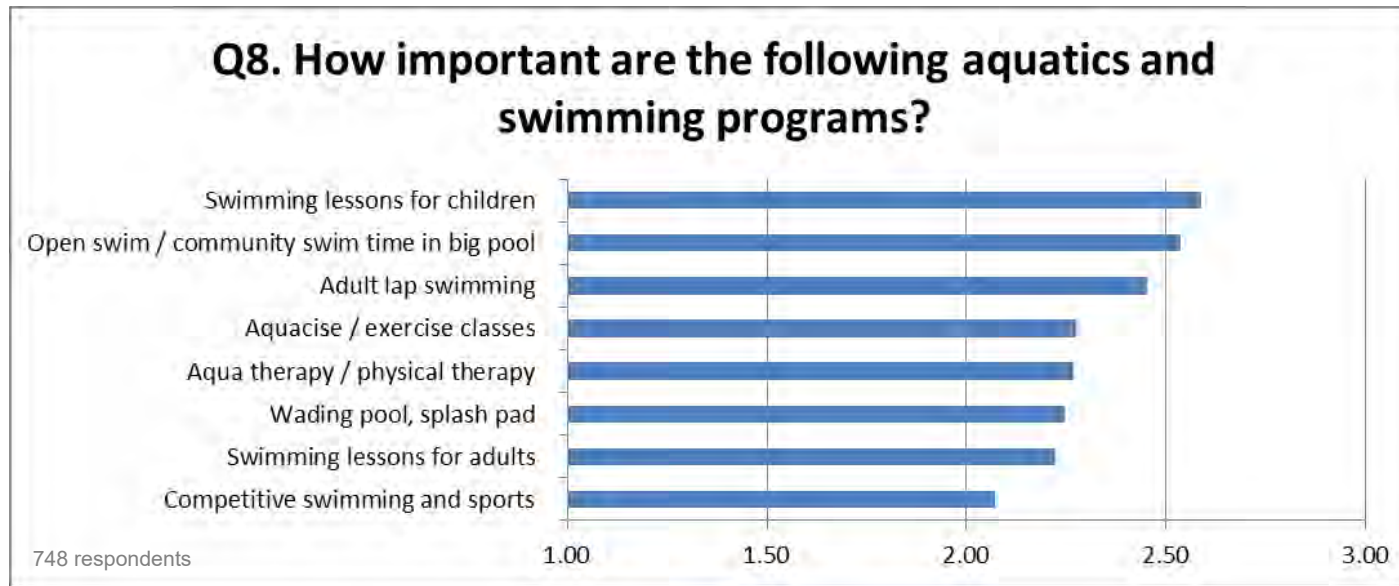

This chart shows average relative importance as rated by survey respondents. Respondents had the option to rate each item as either "not at all important," "somewhat important," or "very important." Items rated "not important" are assigned a value of 1; "somewhat important" a value of 2; and "very important" a value of 3. The chart shows the average value of all ratings for each item. Higher average ratings indicate higher relative importance to the survey respondents.

Q9. For aquatics and swimming programs, how important are the following items?

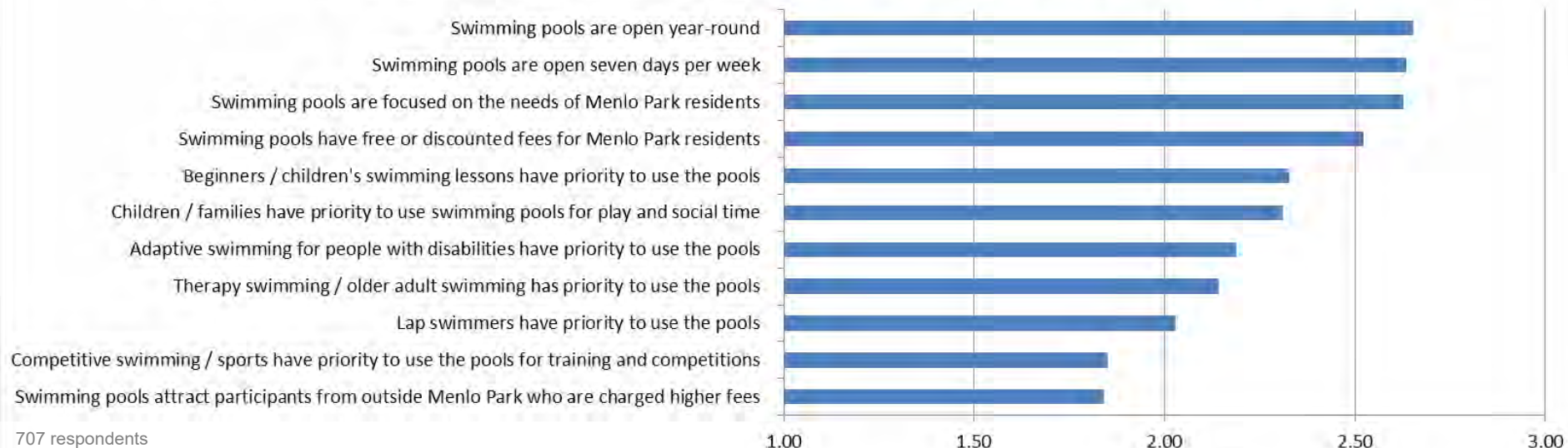

This chart shows average relative importance as rated by survey respondents. Respondents had the option to rate each item as either "not at all important," "somewhat important," or "very important." Items rated "not important" are assigned a value of 1; "somewhat important" a value of 2; and "very important" a value of 3. The chart shows the average value of all ratings for each item. Higher average ratings indicate higher relative importance to the survey respondents.

| Q10. Are there any changes to the city aquatics and swimming programs that would make you use them more often? | |
|---|--|
| 1 | As stated above, the new scheduling system is awful at Burgess. It is almost impossible to get a swim lesson and even if you get one that's usually it. There's no consistency unless you have the ability to sit at your computer and wait for when they open on the dot. It's not equitable to those that can't do that, don't have help with scheduling, work full time away from a computer, etc. |
| 2 | Longer hours open lap swimming before or after work |
| 3 | More open times for Menlo Park residents |
| 4 | Longer hours and open year round with better hours for working families, reduced fees for teachers |
| 5 | More beginner swimming lessons for kids |
| 6 | More open swimming |
| 7 | Yes! We would definitely use the pool more if adaptive swimming was available. There is a huge need for it in the community with years long waiting lists that aren't moving because there aren't facilities available. Water exercise classes for adults and seniors would also be great. |
| 8 | My family trying to do lessons for a short period of time. Each time we came, the instructor was different so I had to keep explaining to them my child's skills and because there were multiple kids in the class, the instructor really barely got to know my child and I felt like it was a waste of time |
| 9 | 0-3 infant and toddler classes |
| 10 | Good and clean locker rooms. Warm pools |
| 11 | - family membership (monthly or annual) is needed - open swim for children 7 days a week for multiple hours, year round, not just summer - baby pool open 7 days a week, year round |
| 12 | Tim Sheeper has done an amazing job in the past managing the Menlo Park community pools and I truly hope Menlo Swim and Sport will continue to operate the pools offering a wide array of programs to a diverse number of people. |
| 13 | No |
| 14 | Current programming is excellent, accommodating a wide range of users in equitable fashion. |
| 15 | More swimming master's programs. |
| 16 | Several. The pool has become a profit center for Team Sheeper to the exclusion of the community needs. There should not be teams such as PASA (Palo Alto Stanford Assn.) using the community pool. This activity belongs at Stanford, School pools or Country Clubs, not Burgess. Sheralee Beebe's senior exercise classes were very popular and even oversubscribed, yet Sheeper cancelled them for personal animus and replaced with a so called physical therapy class that charges double the cost. There is altogether too much emphasis on elite athletes who come from other areas, some far from MP and who are charged substantially less (hour by hour/lap availability) than the community activities. Also, the baby pool is under utilized and infants (often screaming) are "taught" on the steps of the warm pool, blocking access for disabled people. There are no ADA doors. There have also been incidents where kids have pooped in the pool causing everyone to get out. The locker rooms are also often blocked by strollers because people do not use the family locker rooms. There is an Aqua Fit program but that is not something that older or disabled people can participate in. Ideally the baby pool should be reconfigured and reconstructed to be used exclusively for small kids so that they could be safer, watched more closely, so that there would not be so many accidents. Also there are problems with maintenance that seem to be caused by lack of appropriate attention. To have the warm pool closed for 8 weeks is astonishing. In addition there have been numerous short closures owing to various malfunctions. Apparently this is also the case with Rinconada, also "managed" by Sheeper. Sheeper's entire focus seems to be on the masters program and Team Sheeper expansion and not on the Menlo Park community's needs. |
| 17 | I feel all of the above uses of the pool are important. careful scheduling should be able to accommodate all. Weekends should have plenty of hours for family swim, toddler splash pool. Saturday mornings, programs for kids racing, learning to swim, socialize with friends. Reserve weekdays before 3 for adults. |
| 18 | water wellness classes similar to those taught before covid |
| 19 | Need more open lanes for lap swimming in instructional pool. Currently there is only 1 open lane during the afternoons during the week, which is the only time I can come to the pool. |
| 20 | If Burgess were to offer the same aquafit and aqua wellness programs as in the past, I would love to participate again. It worked quite well in the past. |
| 21 | Bring back wellness exercise classes at 9 and 10 am |
| 22 | Aquafit taught by Sheralee Beebe |

All comments are shown as they were written and submitted by the respondents, and are numbered in the order they were received.

| Q10. Are there any changes to the city aquatics and swimming programs that would make you use them more often? | |
|---|---|
| | Questions above are difficult to answer as I believe that no single 'demographic/audience' (e.g., competitive vs. children vs. families vs. senior wellness) should have 'priority'. My extreme disappointment is in the current Sheeper management approach, he has completely ignored the needs of older people who benefit greatly from whole body/aquawellness exercise (e.g., Ms. Beebe was teaching very successfully for the 3 years I attended 3days/wk). There are few alternatives locally for such exercise and, personally, my own health and mobility have suffered greatly from lack of options I enjoyed with Ms. Beebe's classes. I would plead for getting rid of Sheeper in favor of better programming orchestrated for families and also young and older. Now there seems to be a favoring of competitive swimming even to the point of having Stanford affiliated competitive swimmers being allowed swim time over the needs of Menlo residents. THAT is NOT what I'm paying taxes for. |
| 23 | |
| | <ul style="list-style-type: none"> - Open swim time for families on weekends - Group swim lessons - Open access to lap swimming in the Performance pool (early morning and evening) so that people who work during the day and can't afford Masters can continue to swim - Limiting rental to other organizations at least until 2023 when the new MPCC opens - Reasonable pricing so all Menlo Park residents can attend - Menlo Park should take back ownership of the pool and end the arrangement it has with its for-profit contractor that has been crowding out public access in favor of private programming. |
| 24 | |
| 25 | If the pool had lap swimming available for drop in residents, I would be thrilled! |
| 26 | More open swim |
| | Better swim lessons- we have done the group lessons and the coaches just play around most of the time and don't teach |
| 27 | |
| 28 | See above - lessons for infants/toddlers are main interest |
| | We would love to see more private swim lesson times offered. We're really struggling to book swim lessons and to find space on a swim team. |
| 29 | |
| | <ul style="list-style-type: none"> - Open swim time for families on weekends - Group swim lessons vs. private lessons - Open access to lap swimming in the Performance pool (early morning and evening) so that people who work during the day and can't afford Masters can continue to swim - Limiting rental to other organizations at least until 2023 when the new MPCC opens - Reasonable pricing so all Menlo Park residents can swim - Menlo Park should take back ownership of the pool and end the arrangement it has with its for-profit contractor that has been crowding out public access in favor of private programming. |
| 30 | |
| 31 | More family friendly, more affordable, more access outside of work hours |
| | I love swimming and live near the pool but never go because of the fees and difficulty getting lane time. It seems like it's always occupied with something that has little to do with Menlo Park families swimming. Please consider taking the pools back from whatever contractor runs it and opening up to Menlo Park families. In contrast, we use the library three times a week and the basketball arena for school basketball teams. ; Longer hours. Less Masters swim. Fewer individual classes and more group classes. More "slow/beginner" lanes. Cheaper rates for city residents. Especially while other pool is closed. |
| 32 | |
| 33 | More open swim times throughout the year. Family memberships! |
| 34 | More swimming space for families with young kids. |
| | Same as above - offer physical therapy/aqua therapy classes for seniors that are taught by trained aqua therapy instructors without sacrificing the space in the pool for the classes. Would prefer deep water aqua therapy classes so children learning to swim could be in shallow area that we would walk through to reach deep water. Need to change direction of area pool dividers to create a big deep water area across the end of the pool. |
| 35 | |
| 36 | Less expensive; Better advertising to encourage people to use the facility and make them aware of the various ways they can do so. |
| | Ensure that the wading pool is open so that adults are not bringing toddlers into the instructional pool. There have been three incidents involving toddlers that I have observed because of this lack of wading pool availability. |
| 37 | |
| | Our family used to take full advantage of the open swim time, especially during the weekends. Several years ago, however, the pool started restricting the number of people able to swim at a given time, and we would show up only to have to wait in line for an indeterminate amount of time. We pretty much gave up going to the pool after being told to wait in line too often. But when the weather is hot, and I drive by the pool, I am disappointed that swimming there no longer feels like a bankable option. |
| 38 | |
| 39 | No. The pools have the best programming and hours of operation in the Bay Area. |
| 40 | I love the water wellness program taught and supervised by the physical therapist |

All comments are shown as they were written and submitted by the respondents, and are numbered in the order they were received.

| Q10. Are there any changes to the city aquatics and swimming programs that would make you use them more often? | |
|---|---|
| 41 | More open swim / splash pad availability, and a season pass pricing option for families (\$28 every single time is prohibitive) |
| 42 | Bring back Sheralee Beebe to teach aquacise classes. |
| 43 | More open swim time! |
| 44 | Longer hours for family swim (Open earlier so small kids can use it since they nap in the middle of the day). Longer season for the baby pool, not just a couple of months in the summer. |
| 45 | Public swimming availability seems severely limited, especially on hot days... |
| 46 | The chlorine level is extremely high at Burgess. |
| 47 | I know lifeguards are hard to come by and that's limiting hours and activities that are available. I think it's important for the community to understand that and not just complain about the lack of hours. |
| 48 | I'm a disabled 49 year old. I recently had to join a private pool instead of swimming at Burgess 3-4 times a week because of lane availability. I'm only able to use the warm pool because I cannot manage the ladders. I had been at Burgess pool on several occasions when it was designated lap swimming time and have either been asked to leave my lane for a lesson (of course they will throw me out when lessons cost \$76 per half hour!) or they have allowed families and children to occupy the lanes (when it wasn't free swim). The facility isn't ADA compliant (slippery locker room floors and difficult to open doors). I'm glad I could move to a private pool but am concerned about the community members who can only swim for exercise and have extremely limited times and resources to do so. The community is not prioritized- Tim Sheeper is profiting off of this pool. It's ridiculous to pay \$76 for a 30 minute lesson also! When I learned to swim in SF, it was free to the public. Public swimming pools shouldn't cater to the wealthy elite. You are doing a disservice to a lot of the community. |
| 49 | Warmer water, some hours dedicated to handicapped / seniors |
| 50 | At the present time there is No Aqua Wellness Program. A program designed for seniors with a focus on balance, coordination, posture and over all movement and flexibility. Seniors benefit from the program pre and post surgery- of knee and hip replacements. |
| 51 | The locker rooms at Burgess are in serious need of upgrade both in terms of space and quality |
| 52 | Probably not. We are fortunate to have a pool at home. |
| 53 | We use them a lot already, but wish they splash area for little kids was open more during the year. |
| 54 | <ul style="list-style-type: none"> - Open swim time for families on weekends - Group swim lessons vs. private lessons - Open access to lap swimming in the Performance pool (early morning and evening) so that people who work during the day and can't afford Masters can continue to swim - Limiting rental to other organizations at least until 2023 when the new MPCC opens - Reasonable pricing so all Menlo Park residents can swim - Menlo Park should take back ownership of the pool and end the arrangement it has with its for-profit contractor that has been crowding out public access in favor of private programming. |
| 55 | Programs need to be administered and run by the city, not outsourced to a for-profit group that doesn't share the broader community's needs |
| 56 | More time for residents, less focus on non-residents. Current fee differential for resident/non-resident is trivial. There is no City oversight of the program is run (its all for Sheeper's benefit, not for Menlo Park's). |
| 57 | I use the performance pool often for laps and I really appreciate how accessible, clean, pleasant and available it is. It is always being used but it is rarely super crowded--I almost never have to wait for a lane/half-lane, lifeguards are always attentive and moving around, and friendly. This is a menlo park amenity that I really appreciate. |
| 58 | The aquatics programs that are now available have a huge variety of opportunities. These opportunities already cover the full range of what an aquatic program should offer. There is a really fair balanced offering currently of aquatic programs. I would not change a thing nor the current managers of the aquatic program as they have been doing an outstanding job |
| 59 | Yes. Having a shallow (4-5 feet deep) part of pool to exercise (no need for instructor.) Let residents sign up first, then out-of-towners as needed to fulfill numbers.; I don't swim laps anymore because I got kicked too often. Limit numbers in lanes. Extend hours of use. Build an olympic-sized pool!!! Keep fees smaller for MP residents and more for out of towners. |
| 60 | The pool staff seem to do a great job. Balancing the needs of the community is tough, but it seems that Burgess has a good balance. |
| 61 | I just need to learn more about the programs. |
| 62 | more community-wide access |

All comments are shown as they were written and submitted by the respondents, and are numbered in the order they were received.

| Q10. Are there any changes to the city aquatics and swimming programs that would make you use them more often? | |
|---|--|
| 63 | Too many people in the pool -- lanes are often full with 2+ people sharing which is difficult with many skill levels. Focus on incorporated Menlo Park residents who pay taxes to support the pool. There are too many programs and teams using the majority of pool lanes, especially after school and after work when residents want to swim. |
| 64 | I don't use them often now, but I did when my kids were young. I think they should be affordable and accessible for all MP residents. |
| 65 | Tell us us the annual operating costs in these surveys |
| 66 | Changing rooms are an embarrassment. Overcrowded so showers and spinner frequently breakdown. Many people won't go inside, or can't fit so they come an go from home. 1 family changing room, which is used by disabled persons with aides as well, is way to inadequate. Another pool is required for the number of participants. This is one case that i you build it they will come.; Expand and modernize changing rooms Add extra teaching/camp pools. Noise level & waves make classes and teaching in the same pool near impossible. Have city staff responsible for oversight visit every day. There is a lack of communication between departments so that repairs take months. I went to the city offices and spoke to two épatements about a necessary repair in the dressing room. Although pool staff said they conveyed the need city staff didn't follow=thru. The pool seems a low priority for city staff. Ensure there is always a user representative that is on the recreation committee The pool management is excellent so retain them. |
| 67 | Make them (pools, swimming lesson, lap swimming, etc) less expensive so that more people can take advantage of pool usage. Esp in the Belle Haven neighborhood. |
| 68 | Cheaper prices - \$9 from \$6 is a steep price increase for lap swim. The triathlon club is also incredibly expensive. Swim lessons are also very very expensive. |
| 69 | More aquacise classes offered in the evening |
| 70 | More open hour for families, more swim classes for children, priority for MP residents |
| 71 | More swim classes for kids and more open hour swim. |
| 72 | I would like to see more family and open swim time. |
| 73 | Group classes for children at lower cost (can't afford private lessons), especially in non-summer seasons; accessible options for swimming teen with disability |
| 74 | Ability to reserve/rent an area of the pool for private lessons with an instructor that we pick |
| 75 | Laps available for any swimmer at all times pool is open. Should not have to join MAster program to swim in early am |
| 76 | More available times for individuals with some disabilities. Warm pool restrictions so that regular lap swimmers do not take up the available lanes when bigger pool is fully occupied. Warm pool accessibility needs to increase for adults with individuals with disabilities during the daytime (esp mornings) summer time. Currently, swimming lessons for kids have priority. |
| 77 | See comment above about timing availability! |
| 78 | I thin k Tim Sheeper has done a great job balancing aquatic programs and managing the pool facilities |
| 79 | It's been very hard to get swimming lessons, even when you are able to book one, not having continuous progress (monthly/quarterly) lessons doesn't help kids to actually learn how to swim |
| 80 | More options for kids classes |
| 81 | Having more coaches and times spots to choose. I haven't sign my kids because you don't have enough people. |
| 82 | No |
| 83 | All of these programs are important. Group swim lessons are more important than private swim lessons. Youth competition, masters swimming important. Lap swimmers can have more people per lane to make the best use of our limited pool resources. Should be plenty of open swim on weekends. |
| 84 | I'm a longtime resident and have been happy with how Menlo Swim has been managed. |
| 85 | Please please keep masters swimming through team sheeper as it currently is. Tim does an amazing job |
| 85 | The swimming programs at Burgess have been an important part of my mental and physical well-being. The pool is well-run, clean, professional and a highlight of living in Menlo Park. They cater to a wide variety of individuals and groups. Nothing is perfect, and sure, there are times when I wish I had my own lane or something, but the quality of the pool and it's programs is better than any other that I have seen from visiting others around the area. I can't fathom that the city would contemplate wrenching away such a well-run pool from its residents. |

All comments are shown as they were written and submitted by the respondents, and are numbered in the order they were received.

| Q10. Are there any changes to the city aquatics and swimming programs that would make you use them more often? | |
|--|---|
| 86 | My entire family (2 adults and 2 kids) have been regular users of the aquatics programs for years, including drop in casual, Childrens swim lessons, Childrens competitive swimming including the summer league, bday parties, masters swim team, and adult lap swimming. The existing program is top notch and serves the needs of Menlo Park residents very well. It also provides jobs for local young adults and kids. During the pandemic, they kept programs going and provided an invaluable outdoor activity resource available to our community although it was extremely challenging to do so. The current management of the aquatic programs and pools is excellent. |
| 87 | No; None |
| 88 | no |
| 89 | I think the aquatics programs are great. I swim Menlo Masters, I play women's maters water polo, our kids did swim team at Burgess, lots if local kids get good jobs and experience at Burgess. I think Tim Sheeper and staff have done an amazing job utilizing the pool for everyone. |
| 90 | Please do not change anything. We have a great aquatics pool operation. |
| 91 | The free swim option for locals are limited and unwelcoming |
| 92 | mmm no |
| 93 | The City's aquatic programs are already great and I use them often. Please don't make any changes to the current operator or operations. |
| 94 | More swim lesson availability and consistency. |
| 95 | I don't use the pool, can't tolerate the chlorine for long periods.. |
| 96 | No; No.; No. No. No. this survey will not allow me to continue. Is it designed by swimming people? Please let me finish the survey. |
| 97 | The pool times can be set for different priorities during different times of the day and different days of the week to accommodate different groups. It's not possible to have lap swimming at the same time as children and families playing in the pool. |
| 98 | Whoever runs the pool, please keep it open and available for the Menlo Park residents |
| 99 | Mote classes for children, more open swimming opportunities for families |
| 100 | More affordable swimming lessons for children. |
| 101 | The teamsheeper service that is used to sign up for lessons is very inefficient and not user friendly-- I always have trouble with it and have had to reset my password multiple times. Also we are begging for swim lessons as is every other family we know. We've never been able to get them, only a few privates. I feel like people are elbowing each other in the face to get to the lessons first by signing up right at 12:00, and everything is gone within 3 minutes. It's a terrible system and perpetuates inequity for those that cannot drop everything and sign up midday. Water safety is a necessity for everyone, we should better be able to meet the needs of more families. |
| 102 | I am a lap swimmer who would like to be able to swim after work 4-6. I would love some lanes open then. |
| 103 | I think it's important to figure out a way for all the users to have some time. |
| 104 | Proximity |
| 105 | Is there a summer pass for families? What kinds of programs are there for teens who might be interested in teams but are not ready to compete? |
| 106 | I will likely use Burgess if Tim Sheeper is in charge of the facility. If the city takes over and shuts down Menlo Masters, I will likely use another facility bc there probably will no longer be a team and I'm a competitive swimmer. I occasionally lap swim but I use Burgess, far and beyond, primarily for the Menlo Masters swim team. |
| 107 | Three rather than two masters swim sessions on weekday mornings. |
| 108 | Keep the pool open As many hours as possible looking Forward to the new Belle Haven pool |
| 109 | The Burgess pool has programs for all ages and needs. I am really impressed with how it is always full of swimmers and families, and how it was the first facility to be opened during the pandemic. I would not like to see any changes in the programs. |
| 110 | Integrity will triumph. Mr Sheeper is a man of integrity. He balances his passion and priority for community involvement with viable business needs & ethics. Menlo Park is fortunate to have such a person at the helm of this aquatics facility. He deserves more value & recognition for all his behind the scenes time, initiative and problem solving than what he gets. |
| 111 | Menlo Swim and sport is the best aquatics program Menlo Park ever had. I have lived in Menlo Park since 2004 and the pool hours were very unreliable before Menlo Swim and Sport started running it. |

All comments are shown as they were written and submitted by the respondents, and are numbered in the order they were received.

| Q10. Are there any changes to the city aquatics and swimming programs that would make you use them more often? | |
|---|---|
| 112 | The Menlo Park Swimming pool programs have been a benchmark not only for the bay area but for California for years, they serve the elderly, disabled, kids and competitive athletes in more ways than any other pool in the surrounding counties ; Every time i want to go there are open lanes and it is super easy to get in and out. I do not see the need for change; Every time i want to go there are plenty of lanes available, i do not see the need for change. MP pools are one of the few that operate 24x7 from 6 am to 9 pm every day. |
| 113 | Competitive activities belong elsewhere, not in a community pool. They should not take priority over community needs |
| 114 | Aqua Fitness and Wellness the way it used to be pre-pandemic |
| 115 | Any kind of infant/baby/toddler swim lessons on weekends. Everyone I know either gives money to La Petit Baleen or private clubs for this. It's a missed revenue opportunity. |
| 116 | More lessons, charges less |
| 117 | Swimming pool should be closed and heated |
| 118 | Our main focus is swim lessons for children. Group lessons are all booked and private lessons are much too expensive. |
| 119 | More family swimming time during the week and weekend. More group swimming classes for children |
| 120 | My experience of offering time for families and social time is that there will be minimal use. And when this is offered, there is more maintenance and upkeep required simply due to the nature of activity offered. |
| 121 | Longer hours in the evenings in the summer. We frequently want to go swimming after 6:00 p.m. more space for swim lessons, been trying for a year to get in. More family locker rooms so we can all shower and dress at the same time together. |
| 122 | Love the pool! Please keep it here! |
| 123 | Lounge chairs or more space for sitting would be nice. We just come for swim practice and leave. An open swim area or time (without lane lines) would be nice for just enjoying the pool. |
| 124 | Include unincorporated Menlo residents as residents |
| 125 | I would use them a lot less or not at all if the current pool management is changed and the city takes over the management of the aquatics program. |
| 126 | Tim Sheeper has a well run organization throughout my multi year membership and I was especially grateful during the pandemic. Burgess pool and staff have positive health benefits for the community. |
| 127 | dog pool maybe?? (dedicated small one), or dogs come on closing days |
| 128 | More lap and family swimming options and better rates for residents - ie closer to free or highly subsidized. |
| 129 | I used the kiddie pool and the large pool when I had small children. Once the pool became "private " we never felt welcome again and have never returned. My older daughter took swim lessons at Burgess pool but once Sheeper moved in we went to SCRA. Both my children learned to swim at SCRA. I was and still am livid that Menlo Park build this beautiful new pool for Sheeper. Why can't the City run the pool they did before? |
| 130 | community open house - introduce aquatic programs to citizens |
| 131 | We use the pool close to daily during the summer, and 3+ times a week during the school year. We are heavy users, nothing could make us use the pool more. I look forward to the Belle Haven pool being complete - it is closer to our home. Re: Therapy Swimming and Adaptive Swimming. I've never heard of a need for those - is that something the community is asking for? |
| 132 | In the past there was some limitations on time slots open to general swimming use before the pandemic so would like to see that during summer more hours open to the general public use rather than competitive program use. |
| 133 | Aquatics fitness drop in classes on weekends for adults |
| 134 | I'd like to note that Tim Sheeper has been running an excellent aquatic program that juggles the needs of many people who use the pool. It is amazing. I've never seen the pool empty. It would be a shame to try to fix something that isn't broken. |
| 135 | More time and more lanes open for open family swim |
| 136 | Increase the number of slots for swimming lessons so that more kids can learn how to swim. |
| 137 | More pool facilities to meet the size of our collective community needs. Burgess is great, but gets incredibly crowded. We have outgrown that one facility and need more space for families. |
| 138 | More lap swim times/lanes |
| 139 | More open swim hours. |
| 140 | Devote half the instructional pool for play . |
| 141 | Clearly defined hours for different activities such as fun, open swim vs lap swim |

All comments are shown as they were written and submitted by the respondents, and are numbered in the order they were received.

| Q10. Are there any changes to the city aquatics and swimming programs that would make you use them more often? | |
|---|---|
| 142 | I swim 5 times a week with masters-incredible program. Disaster if we lose Tim Sheeper. Before Tim took over, there was no swimming community. City staff scribbled a workout on the white board (when city ran it) , and went to sit in office. |
| 143 | Tim Sheeper has done a tremendous job running the Burgess pool. I remember back when the city ran the old pool and the hours of lap swim availability and swim programs has gone from unsatisfactory to outstanding under Tim's leadership. |
| 144 | The current situation is ideal for my needs. |
| 145 | Tim Sheeper and his team have developed one of the most impactful, participatory, an successful swimming programs ij the entire state. He and the team are a credit to the community. |
| 146 | The hours are currently very extended. |
| 147 | Having the city invest in the pool and keep locker rooms in better shape. Also continuing the excellent array of a supportive aquatic community of all ages and abilities as Menlo Swim & Sport does now. |
| 148 | More lap swimming hours and more lanes open at the same time |
| 149 | Less focus on competitive swimming including Masters |
| 150 | Current program is fine for me, but I would hate to see a reduction of hours for lap swimming or Masters. |
| 151 | More lanes! Bigger pools. |
| 152 | No. The programs over the past 12 years have served our family of four from 5 yr olds to 16 yr olds |
| 153 | Lower the water polo fees |
| 154 | I swim nearly every day at the pool. It will be very very sad if the Master's swimming is discontinued. There is a very large group of people from Menlo Park and surrounding who are a part of this group and desperately want it to continue. I honestly don't think there is another person who could do a better job of this than Tim Sheeper; he is fair, honest, devoted, frugal. Please, please let him continue to give hundreds of us to be led by his skilled and thoughtul lead.; I am there nearly every day. I think Tim has managed the masters program, the lap swimming, elderly program, and swimming for the children really marvelously. |
| 155 | Swimming lessons for children should be accessible and affordable ,sliding scale for all Menlo Park residents . |
| 156 | no |
| 157 | if it is free and open to the menlo park residents; more accessible. it's so hard to book classes for my kids-have not been able to get one since March. They can't swim yet. |
| 158 | adult swimming lessons, water exercises |
| 159 | more and longer flexible hours; more and flexible hours |
| 160 | Open swim I'm the mornings during summer break and other school breaks throughout the uear |
| 161 | More access to lap swimmers. Means more hours of availability... |
| 162 | I was very excited when the new pools at the Arrillaga Center were opened but then found to my dismay that there was almost no recreational swim time available and what was available was in inconvenient little 30-45 minute slots in the late evening sessions; almost all the pool time was for scheduled narrow-use activities, heavy on the sports programs. I had pretty much given it up, but then saw there was a dispute with the current, and soon to expire, program provider and saw some hope. They need to go, in my opinion, and the contract given to someone who understands what a community pool, that it is not just a pool for them to run their sports programs. |
| 163 | focus on residents! |
| 164 | less fee for open swim for residents |
| 165 | cost and expense, changing times of open swim, offer MPCSD pool access, include 8ped |
| 166 | Staff should reflect the community, otherwise it feels that we are being pushed out and not important. Inclusion is vital. |
| 167 | Longer hours, year round as weather permits. |
| 168 | No |
| 169 | Offer cheaper prices to seniors. Have a pool with higher temp for seniors + disabled that can not tolerate the cold pools. Water therapy for autistic people? |
| 170 | More group lessons for kids! |
| 171 | I'm a frequent user. It's important that the pools are heavily used by regular users. Otherwise, the expense of keeping the pools open and the costs to users will be too high. |
| 172 | lower fees for seniors/more laps(?) for seniors |
| 173 | Longer hours |
| 174 | I appreciate that folks inside and outside MP can use the pools and it's totally fair that non residents are charged more. |
| 175 | Need more bike racks. |
| 176 | More for seniors |
| 177 | Non/competitive lap swimming for teens |
| 178 | Baby pool all week in summer. Lower fee or year pass for family swim |

All comments are shown as they were written and submitted by the respondents, and are numbered in the order they were received.

| Q10. Are there any changes to the city aquatics and swimming programs that would make you use them more often? | |
|---|--|
| 179 | cleaner bathrooms |
| 180 | More children lessons with qualified teachers |
| 181 | Warmer water! |
| 182 | open swim opens at 5:00am to 6:30pm |
| 183 | If it is less crowded |
| 184 | baby swimming classes with flexible hours and fees |
| 185 | Have more times on weekends and later hours during week. |
| 186 | Accessibility to older/disabled people. Treating Belle Haven Pool equal to Burgess. |
| 187 | open more hours |
| 188 | Pool should be open year round to everyone |
| 189 | Reduced fee/free for residents w/ increased hours of operations for families. |
| 190 | Just waiting for new Belle Haven Pool |
| 191 | Bell Haven doesn't have a pool or free programs for our teens. |
| 192 | A Menlo Park resident should not be charged - ever! |
| 193 | PT in swimming |
| 194 | Price and location |
| 195 | More printed information mailed to residents |
| 196 | No not really |
| 197 | n/a |
| 198 | Current swim programs for free private lessons. |
| 199 | Reduce fees. For heavens sake, if a wealthy supported community can't afford to let its residents use these facilities for free or for \$2, what community can? |
| 200 | splash pad < lane swimming |
| 201 | I've never used the pool because open swim times were so limited - need more adult only hours |
| 202 | We would use them more often if they were available. They book very fast & not all of the time frames work for full time working parents working more than one job. |
| 203 | Free/family swim last longer on weekends during the summer. |
| 204 | SHADE, aquatic safety classes, level in between kid and swim team, low chlorine, onetta harris open AFTER business hours during weekdays/all day weekend |
| 205 | Before renovation, the lap swim in Belle Haven was \$10/visit. This is too expensive for the people in Belle Haven who have lower incomes than the rest of MP residents. It needs to be cheaper and this will help it be more inclusive. These types of policies and barriers are the systemic inequalities that have led to less Black and Brown people who know how to swim. Needs to be discounted for Belle Haven residents to help fight these systems. |
| 206 | ask me after belle haven pool opens; Good luck with all that :) water aerobics in conjunction with senior center at onetta harris? ccmp? |
| 207 | all the above activities are important and could be divided with equal fines [sic] on a schedule |
| 208 | n/a |
| 209 | If there were classes for kids learning to swim on Saturdays/Sundays or in the afternoons 4-6pm during school days. |
| 210 | easier access to kids classes; they are always waitlisted! |
| 211 | splash play section for toddlers |
| 212 | N/A |
| 213 | Que alla piscinas para terapias cerca |
| 214 | I would like to sign up for children's swimming lessons of limited duration, say one or two week's worth of classes or private lessons, not an ongoing commitment I have to cancel later. |
| 215 | My family has used the Burgess pools for years, and it was one of the big reasons we moved to Menlo Park. I do see the challenge of balancing the use of the pools for training and open swim, but we are blessed to have two pools at Burgess to balance things out. I unfortunately think we need more pools than we already have, and hopefully opening Belle Haven will help alleviate the strain. I do think that people from out of town should pay significantly more than they do for these services - consider upping non resident fees. I also wish that there was more of a "community" feel to the pool. Say food truck night, or movie night or something like that to get people to come together and connect in a friendly way, similar to the way Ladera Recreation Pool is run. |
| 216 | no tengo cambios |
| 217 | awareness of offerings |
| 218 | It would just be nice to have all info @ our fingertips! Did not even know we had a recreational area that offered these amenities! |
| 219 | Would like evening hours during the week and weekends for learning to swim for adults. |
| 220 | Have the pool (longer hours) for the residents of Menlo Park, not just for the polo teams. |

All comments are shown as they were written and submitted by the respondents, and are numbered in the order they were received.

| Q10. Are there any changes to the city aquatics and swimming programs that would make you use them more often? | |
|---|--|
| 221 | Smaller classes or affordable private classes option |
| 222 | Maybe a day only for the seniors. Some might be intimidated by youngsters |
| 223 | Pools in Menlo Park should be for Menlo Park residents only; however a resident should be entitled to bring guests. |
| 224 | We love the pool! The baby pool area is wonderful. But the biggest thing that keeps us from going to the pool is the cost. It would be great if fees were reduced for residents or for parents with young children. |
| 225 | A lower cost for pool use |
| 226 | Priority on lessons, masters club, and swim team |
| 227 | I'd love more availability of swimming lessons (esp private lessons) for kids and the confidence to schedule them with more consistency (at the moment right now it's a giant scrum whenever lessons become available and swimming is something you need to learn consistently not in fits and starts). The situation is so inconsistent we've considered joining a private club just to be able to get consistent swimming lessons for the kids even though we love the instructors at Burgess. |

All comments are shown as they were written and submitted by the respondents, and are numbered in the order they were received.

| Q11. Please tell us your ideas, needs, and suggestions for the city aquatics and swimming programs | |
|--|--|
| 1 | More pools |
| 2 | Additional times for swimming lessons and open year round |
| 3 | More exercise & swim lessons. If at all possible to also allow lap swimming |
| 4 | Accessible entry/exit, adaptive swimming, adult water exercise classes |
| 5 | My husband works at a pool so we usually just go there. But it would be really nice to go to a pool in our own neighborhood. But I just found it too expensive and figured it wasn't worth it. |
| 6 | Lower the fees for families to swim |
| 7 | Teaching scuba |
| 8 | Cheap group lessons for kids; open play time with lifeguards |
| 9 | - family membership (monthly or annual) is needed - open swim for children 7 days a week for multiple hours, year round, not just summer - baby pool open 7 days a week, year round |
| 10 | I love how Burgess has a warmer pool for lessons and a colder pool for serious lap swimmers. It allows for a more diverse range of aquatic programs. |
| 11 | So grateful for the pools! |
| 12 | More master's swim programs. |
| 13 | It is not functional to have the pool operation overseen by a Librarian. He knows nothing of the pool operation. The Parks and Rec. committee appear to care less, and both defer to the City council as being the ones that are call the shots, so they do nothing. This is not just about seniors either: many kids are not athletic but do like to splash around in the pool, with or without their parents. In times past families would come and sit on the grass and just enjoy the pool. I don't think that has happened since Sheeper took over. Sheralee's program or something similar needs to be in place for elderly or disabled people. There needs to be better supervision of the programs, perhaps by the Parks and Rec. Committee, but NOT by Sean Rineheart who could care less and responds that any overview is the responsibility of the Council. There also needs to be some kind of auditing since the whole operation is run purely it would seem for profit for Sheeper, not for community benefit |
| 14 | Need water wellness program/classes similar to what there was before covid |
| 15 | (Please see above.) I am mainly interested in the aquatics program. |
| 16 | Bring back regular aqua wellness exercise for seniors three times per week |
| 17 | - Open swim time for families on weekends - Group swim lessons - Open access to lap swimming in the Performance pool (early morning and evening) so that people who work during the day and can't afford Masters can continue to swim - Limiting rental to other organizations at least until 2023 when the new MPCC opens - Reasonable pricing so all Menlo Park residents can attend - Menlo Park should take back ownership of the pool and end the arrangement it has with its for-profit contractor that has been crowding out public access in favor of private programming. |
| 18 | Residents come first - this is a PUBLIC pool |
| 19 | I'd like to see increased access, eg, open swim time for families on the weekends, open access to lap swimming, limiting rental to private parties, holding group swim lessons rather than private |
| 20 | Longer hours. Less Masters swim. Fewer individual classes and more group classes. More "slow/beginner" lanes. Cheaper rates for city residents. Especially while other pool is closed. |
| 21 | We need affordable family membership options to attend open swim times. |
| 22 | There is a huge need for older residents of Menlo Park & surrounding areas to have year-round warm water and deep water aquatic therapy to strengthen our legs, core, gluts, and improve cardio. But classes need to be taught by experts who can best help us.. not just swimmers or exercise teachers. The need is growing as more of us in the area grow older and are living in our homes. The city needs to give us the SAME amount support that it gives children and adults (who are not seniors) AND dogs!! |

All comments are shown as they were written and submitted by the respondents, and are numbered in the order they were received.

Q11. Please tell us your ideas, needs, and suggestions for the city aquatics and swimming programs

| | |
|----|--|
| 23 | <p>In the name of EQUITY, please invest in the children of District 1. The city council seems to be very lax in this regard.; The current MSS contractee places profits over stewardship and does not have safety of its guards and pool client as a priority. I was a Cal OSHA Safety Inspector for nine years. Without the Belle Haven pool there seems to be no emphasis on providing the children of District 1 aquatics access. The Belle Haven pool project is already well behind schedule with no urgency to improve the timeline. Why is it that EVERY maintenance project at Burgess runs well beyond the intended deadline? The recent Burgess chemical changeover is a perfect example - a one month project took four months. The Burgess instructional pull pump is another. It was known that the pump was failing several months before it failed. I know because I informed a lead lifeguard and two MODs of it failing due to the noise it was emitting six weeks before it failed. "They wanted to see how long they could go before having to replace it." "We knew three months before the failure." Why did it take 8 weeks to replace it? "We have to go China." - NO, there were domestic suppliers at a little higher cost but not overly so. I checked. "There are supply chain problems." - YES and that is why you expedite shipping (with an added cost). "We have to get a contractor." - YES of course, really?. So WHY did a two-week project take eight weeks? What are the cost overrun impacts on City budgeting and why is there no priority to execute maintenance completely, accurately and on time. As a 41-year facilities engineer and manager at Stanford I can assert that the city maintenance of the pool is SUBSTANDARD and would never have been tolerated in my Stanford department. It is costing our residents more than it should. The restrooms have not been maintained in a healthy manner and my five complaints and those of others have been met with "We have tried but the city will not do anything about it." This is shameful. Several women have told me that they have developed foot fungus from the women's restroom. If the condition of the men's restroom is any indicator then, I believe them. It took 10 months to replace a shower head in men's restroom. On three occasions, I have removed hair piles from both men's restrooms shower drain troughs (and reported to the MOD). Health and safety inspections appear to be telegraphed so that few or no potential areas of improvement are identified. I strongly suggest that the city NOT take over the pool and that a NEW pool program provider be contracted. I strongly suggest that health, safety and maintenance inspections be taken seriously for the good of the facility and the safety of the residents.</p> <p>How many MSS rescue incidents have taken place in 2021 and 2022. How many required 911? Have any rescues resulted in hospitalization? How often have in-service lifeguard training sessions been conducted in 2022 where the guards actually practice in-water rescues? Does MSS provide post-event counseling for guards who have been involved in rescue events? Saving the life of a drowning swimmer is an impactful event for the lifeguards.</p> |
| 24 | Allow lap swim with children |
| 25 | More group classes for children |
| 26 | <p>We have a pool shortage. We need another community pool option in MP and more swim instructors at the existing pool. It's impossible to get lessons at all, and with any sort of regularity. What about a snack bar at the pool as a means of revenue and community building?</p> |
| 27 | <p>Stop prioritizing Tim Sheeper profiting off of a public resource. His programs should be eliminated or cut down. The pool should ensure disabled community members have equal access and time to use the accessible pool. The elimination of the former Aqua Wellness class was devastating to most of the 40+ members who used that program. The current program is nowhere as inclusive and popular as the previous Aqua Wellness classes run by Sheralee Beebe.</p> <p>You should partner with one of the disabled community members to ensure needs are met because the current staff are clueless.</p> <p>I don't have children but see how unfair the pricing of swim lessons are. Only wealthy community members can afford the prices Sheeper sets. And this obviously impacts the priorities of pool management when they deny patrons the use of the pool in order to make profits off their unreasonably priced lessons.</p> <p>The swim teams out of Palo Alto should not be using Menlo Park pools when space is at a commodity for Menlo Park residents.</p> |
| 28 | Please consider growing needs of aging / disabled population |
| 29 | Consider enlarging the Kiddie Pool to attract more infants and toddlers. Reinstate a real Aqua Wellness Program that meets the needs of seniors. We do not need to jump around raising our cardo rate. We need strength training, balance, posture awareness, and muscle toning. |
| 30 | The locker rooms at Burgess are in serious need of upgrade both in terms of space and quality |

All comments are shown as they were written and submitted by the respondents, and are numbered in the order they were received.

| Q11. Please tell us your ideas, needs, and suggestions for the city aquatics and swimming programs | |
|---|---|
| 31 | I wish there was more access to the performance pool to people outside of the Masters program |
| 32 | <ul style="list-style-type: none"> - Open swim time for families on weekends - Group swim lessons vs. private lessons - Open access to lap swimming in the Performance pool (early morning and evening) so that people who work during the day and can't afford Masters can continue to swim - Limiting rental to other organizations at least until 2023 when the new MPCC opens - Reasonable pricing so all Menlo Park residents can swim - Menlo Park should take back ownership of the pool and end the arrangement it has with its for-profit contractor that has been crowding out public access in favor of private programming. |
| 33 | City run programs at two pools offering a full range of activities including lessons, open swim, lap swim, exercise classes, play pool. Use for competition only after all other needs meet. |
| 34 | keep it simple. keep it focused on serving residents. |
| 35 | The focus should be on servicing the community. Too many decisions are prioritized so that Team Sheeper can charge more money. If they can squeeze in charged class or program they do The city should be more involved in the programs and fee changes. After the pool opened following the Covid shut down Team Sheeper announced there were no refunds because the rates to swim had been increased so much (this was even though they did not hesitate to lay every one off. Was the city consulted on this, if they were did they seek input from anyone else. |
| 36 | Swim teams are great, but should not be prioritized over more casual use by residents of all ages, including beginning lessons |
| 37 | My only suggestion is not to change the current aquatic program nor change the current aquatic program managers. They do an outstanding job and offer a full range of aquatic programs, it could not be done any better |
| 38 | There's more demand for swim team than availability |
| 39 | Keep up the good work! In a year where other communities don't have enough lifeguards and have had to cut back on hours and programming, the Burgess pool team is doing a fantastic job. One of the best surprises about moving to Menlo! Please don't change anything. |
| 40 | Please do not ruin the wonderful pool programs and services we now enjoy. No one group is unfairly advantaged and all are welcome. We have a year round program that is unique on the peninsula. We are so lucky. Tim Sheeper has done an amazing job running the pool in a professional manner that benefits all users. Too bad you took away the Belle Haven pool.... |
| 41 | Better safety -- often too few life guards and some of them seem distracted. Performance pool should be set to a cooler temperature. Pools are over-subscribed. There should be more difference in resident/non-resident fees so residents pay less and also to discourage non-resident use. |
| 42 | Balance budget |
| 43 | See above. Mandate a pool user rep sits of recreation committee |
| 44 | Swim lessons, esp for young people (beginner level). It would be cool if there was a feeder into a competitive swimming program for kids who are interested (doesn't necessarily have to exist at the Menlo Park pools). |
| 45 | Needs to be cheaper for residents. |
| 46 | Keep it simple and accessible to Belle Haven residents |
| 47 | Group swimming lessons every day for two weeks for beginning swimmers |
| 48 | Learn to swim programs should have highest priority, since they can save lives. Next highest priority should be recreational swimming and recreational pool exercise. Lowest priority should be competitive swimming. |
| 49 | Ideally, more swimming lessons available during after school hours; expanded capacity for childrens' year-round swim team. |
| 50 | I think there should be discounted rates for people who need it for family swim and exercise classes and lap swimming. |
| 51 | Hire more people. |

All comments are shown as they were written and submitted by the respondents, and are numbered in the order they were received.

| Q11. Please tell us your ideas, needs, and suggestions for the city aquatics and swimming programs | |
|---|---|
| 52 | Group swim lessons over private ones. Competitive swimming and masters serve more people per lane than lap swim. Lap swim is important and also important lap swim lanes serve more than 1-2 people per lane to make best use of our resources.; I'm happy with how the pool has been managed. I know this has stirred controversy but we should be doing more, not less, of this. It's well run and available. I remember when it was publicly run and it wasn't as available to residents. The org running it is doing a great job and communicates well - I am on the emails so get updates on changes to schedules, etc. |
| 53 | If there are some residents who feel like the fees are too high for the pool, perhaps some funds could be allocated to help low-income residents or fundraising for nonprofits encouraged. It is difficult in a city like this to make sure all needs are met, so focus on the fact that many are happy with how they are run instead of just listening to those who simply complain the loudest. |
| 54 | N/A |
| 55 | none |
| 56 | Please encourage our existing pool operator to continue doing what they are doing. |
| 57 | nn |
| 58 | The best thing Menlo Park has done was get Tim Sheeper to provide the programming and management of Burgess and Belle Haven pools. Please do not force him out or scare him away due to the complaints of a few malcontents and town grumps. |
| 59 | None - since I don't use the program. |
| 60 | Programas de natación con costos accesibles para niños y adultos, especialmente para residentes de Menlo Park. |
| 61 | I usually avoid the pools because of the expense, crowding and most importantly because I have very sensitive skin and cannot tolerate most pool disinfectants. I used to be an avid swimmer and have neighbors who rely on the various swim programs the City provides, so I'm very much in favor of the City running swim programs for all ages and abilities. |
| 62 | It would be nice to have more options for beginner swimmers. |
| 63 | Offer more swim lessons please |
| 64 | -Programs need to be for low-income residents. |
| 65 | I'm on the Menlo Masters team, moved from Sunnyvale to Menlo Park specifically to swim on this team, that's how much this team means to me. |
| 66 | Burgess Pool is awesome. Well-run, serves a wide community, lots of hours, great activities for all ages and abilities. |
| 67 | Keep the masters swim team & youth Sports |
| 68 | I am impressed with how the Burgess pool is so well run, but I was deeply concerned when I read an article about changing management/programs. My family and I use the pool at least 5 days per week. My 7-years-old does the Bridge program, I do the lap and master swim and I am using the pool to teach my 5-year-old how to swim. Burgess is the only pool that I have seen that always has lanes reserved for free swimming, no matter what time you go, and has enough programs to attend to all ages and needs. Instead of discussing changing how Burgess is managed, shouldn't the city be discussing how and when to open the gymnasium? |
| 69 | Please keep the Menlo Park Pool to the standard it has been created to become. |
| 70 | I really hope that Tim Sheeper will be able to continue overseeing the Menlo Park pools. I appreciate all the work and thought that went into keeping the pools open and running during the pandemic. In general, he is on top of maintenance and ensures the pool keeps running. I joined the Menlo Masters swim team 9 months ago as a fairly new swimmer. Since then I have been swimming four to five times a week. I was fairly new to swimming when I joined. The swimming community whose glue is Tim Sheeper has been the thing that has gotten me through this year. It would be such a shame to see that come to an end. |
| 71 | No business owner can operate with a 1 year contract and retain employees. If Menlo Park City employees only had a 1 year contract, they would all resign and go work for another city. Please treat Menlo Swim and Sport as you would treat City employees and offer Menlo Swim and Sport a 3-5 year contract. I will not vote for these council members again if they let the pool shutdown by having unreasonable, unrealistic negotiation tactics. Other cities envy the aquatics program we have and this is one of the many great things going on in Menlo Park right now. |

All comments are shown as they were written and submitted by the respondents, and are numbered in the order they were received.

| Q11. Please tell us your ideas, needs, and suggestions for the city aquatics and swimming programs | |
|--|---|
| 72 | Please keep them as is, I heard ridiculous comms ts by the major threatening to close the pool or have the city manage them !!! my kids learned to swim here.. I lap swim there and have been a swimmer for all my life- not even in Florida we have the quality of pool program s and management we have here in Menlo Park; MP is already a Mecca for swimming - I know the council is considering changing current management but tis is really a bad idea - if you look at the data MP has more lanes open, more programas available and more access than an y other pool in most of California. |
| 73 | Too much effort on profit, not enough on resident needs. Youth competitive teams belong in high schools and country clubs. Triathlon etc. belong in the ocean. |
| 74 | priority to seniors and disabled to get into and out of the pool and classes for their needs |
| 75 | I love having lap swim available for all hours and Masters swim at convenient times. It also important to me that my teenagers are able to swim laps during regular lap swim times. |
| 76 | I would like to KNOW that the City Council and the Mayor herself have researched all other aquatics facilities owned by municipalities in San Mateo County to see how well this facility has been run since Scheeper took over. If this was done, it would be a well known fact that we are not rivaled in this county in terms of the opportunities offered.; Let Tim Scheeper and his team of professionals make these suggestions and LISTEN TO THEM. Believe me, they know. |
| 77 | More affordable swim classes for kids, it's way too expensive for an average family. More options for group classes. |
| 78 | Please keep Menlo masters |
| 79 | Please keep children's swim teams and summer camp!! |
| 80 | I believe the current aquatics programs are well run and represent the needs of a cross section of the aquatics community. One of the problems has been the closure of the Belle Haven pool for remodeling, which has impacted the utilization of the Burgess Pool. The current contractor of the aquatics program responds to the needs of the pool users. The variety of programs for the elderly, kids and teen swimming programs has been a good mix. Lack of city response to the maintenance issue in the instructional pool for over two months resulted in the elderly jassercize classes and programs to be restricted to the lower temp pool. ; I believe the current aquatics programs are well run and represent the needs of a cross section of the aquatics community. One of the problems has been the closure of the Belle Haven pool for remodeling, which has impacted the utilization of the Burgess Pool. The current contract...See More |
| 81 | Keep Burgess operational! The city needs to support a well run program. |
| 82 | Would love to see a state of the art year round swim complex that is highly subsidized for residents. |
| 83 | Have the city run the pool. This is a City recreation amenity not for outsiders. I am not sure but I think the city had a swim team at one time. |
| 84 | More senior exercise program availability in the pool |
| 85 | During the summer months, provide more space in the performance pool for open swim in the afternoons. |
| 86 | It is so costly to go to Burgess for a family swim. Menlo Park residents should get free or heavily discounted passes to swim. |
| 87 | Love the swim programs! Wish the summer swim team is year round and not as intensive as solo |
| 88 | Adult swim |
| 89 | Keep Tim Sheeper , his vision and creativity are unmatched. He has created a vibrant, friendly, welcoming community for all levels of swimmer. Emotional lifeline for many , through pandemic and beyond. |
| 90 | For those of you who were around prior to 2006, the old Menlo Park pool had limited hours and was too costly for the city to run. Tim Sheeper took over running the new pools and greatly reduced the costs to manage the pool for the city. This was done by bringing in more diverse groups to use the pool - more bodies lowers costs for all. I think it is important to note that a community pool must be shared amongst many different user groups as it is today. There is a vocal group of seniors who want to swim in their own lane and complain about all the various swim programs we are fortunate to have in the city of MP. This kind of access is not practical in a public pool setting and would reduce access to all and greatly increase the cost for the city, the pool operator and users. Let things continue as they are. They aren't broken. |
| 91 | MP is known to have the best public swimming program in the Bay Area, and I'm proud and grateful to benefit from it. |

All comments are shown as they were written and submitted by the respondents, and are numbered in the order they were received.

| Q11. Please tell us your ideas, needs, and suggestions for the city aquatics and swimming programs | |
|---|---|
| | <p>Tim Sheeper has done a remarkable job of accommodating all of the needs mentioned above. Our biggest problem is that the space is too small for the rapidly growing demand for aquatics.</p> <p>Before a final decision please do your homework considering the rapid growth of the popularity of swimming. There was data about these trends when the decision to build a 25 yd instead of a 50 meter pool. When presenting that trend at the time 2 council members told me they wished they had that data when they first made the pool size decision. My astonishment was that they had not done that homework before they made a decision. Please don't make the same mistake here.</p> <p>Before making a decision about Sheeper and the aquatics program please look closely at the community demand. If meets the needs of a large population. Younger people are more exposed and they take that exposure and the benefit of aquatics as they age. ; See above</p> |
| 92 | |
| 93 | Keep the Sheeper team in charge. |
| 94 | Continued maintenance of the pool and infrastructure. Some showers are leaky, wasting water. There was a significant issue with the instructional pool this spring which closed the pool for weeks. Monitoring equipment and replacing things on a schedule is important for extending the life of the pool. |
| 95 | Menlo Park's locker room facilities are run down and in very much need of a modern update. The programs themselves are amazing and my children have enjoyed all levels of participation from lessons to camps and play in the water on hot days. I have enjoyed a superb and inspiring aquatic community of all ages and abilities in Menlo Park and grateful that it's a city who have kept their community pool going while my city and others have closed only for summer use. I do hope expanding use to all is what is being considered and that Menlo Swim and Sport is lauded for their ability to build back after Covid closed the pool as well as the long term impact of pool care and facilities not being invested in leaving one pool down for two plus months. ; I also am grateful for the amazing work the lifeguards & coaches do to train and keep the community safe sound the pool. I got to see first hand a rescue happen during a swim meet and the lifeguards and coaches were amazing and responsive and saved the girl's life! I absolutely want my kids trained in lifeguarding by this team currently running Burgess. |
| 96 | Continue to offer the high quality programs offered that support adult fitness through swimming, especially for older adults. |
| 97 | Have Sheeper manage all the pools & programs. |
| 98 | Team swimming from youth to old age brings life and vibrancy to the pool. It also creates demand for all family member to learn to swim. A greater number of individuals can gain benefit from organized, team, aquatics than any other program - team swimming is the highest density program the city can offer. If the city's goal is to serve the greatest number of community members, then team swimming for all age groups should be the highest priority. |
| 99 | I honestly don't think it can be better run. If this is discontinued much like the gym that the Arrilaga's donated, it will truly be a great loss. I don't think the council realizes they have been given a gift from Tim Sheeper. |
| 100 | Tim Sheeper has been instrumental in utilizing BBAF funding to provide access to children who have little access to aquatic activities and aquatic training. Some of these participants are now working at Menlo Park and other local pools. It's wonderful to see. |
| 101 | Continue Menlo Masters swimming program |
| 102 | I think I about covered it above. I think there needs to be more open swim/mixed use time. A lot more. |
| 103 | I loved to see a year round aquatics program--open swim, lap, lessons for adults, children, seniors etc. |
| 104 | Open longer hours--7 days/wk |
| 105 | I like the pools to be run the way they are currently. I'm very satisfied. No changes please. |
| 106 | <p>Please have kids love soccer, this is such a great program to have for the community. All other neighbor cities have this program!</p> <p>Please keep the kid tennis as much as possible, this is also a great program!</p> <p>Compared to Palo Alto, Menlo Park has so few kid friendly programs(kids below 5)</p> |
| 107 | The pool is extremely important as well as swimming lessons. Please keep this open |
| 108 | None |
| 109 | shrug |
| 110 | the swimming pool should be larger |
| 111 | Open swim area needs to be larger |
| 112 | Have reasonable prices for the community of Belle Haven/Menlo Park. |
| 113 | Clear guidelines/series of classes for infants & toddlers |

All comments are shown as they were written and submitted by the respondents, and are numbered in the order they were received.

| Q11. Please tell us your ideas, needs, and suggestions for the city aquatics and swimming programs | |
|---|---|
| 114 | A gym YMCA or swimming pool |
| 115 | Teach the kids to swim! |
| 116 | more instructors for PT therapy |
| 117 | n/a |
| 118 | To have transportation to and from programs |
| 119 | Low fee (\$2.00/class, visit) for resident adult, Free lessons for resident kids. |
| 120 | heated pool |
| 121 | I think swimming & lifesaving/CPR lessons for kids, in particular, are 3. Every kid should learn how to swim. Also, I was surprised that 3rd parties were managing scheduling pools. Felt dodgy & like a sweetheart deal. Audits? |
| 122 | more adult swim hours |
| 123 | Offer more swim classes for students that have no swimming experience. |
| 124 | Free/family swim last longer on weekends during the summer. |
| 125 | children's swim classes |
| 126 | Free and discounted swim lessons and club teams, especially in Belle Haven. |
| 127 | not swimmer or sports person |
| 128 | n/a |
| 129 | n/a |
| 130 | n/a |
| 131 | Indoor or at least warm water. A clean locker room/changing area for kids/families |
| 132 | esta bien |
| 133 | N/A |
| 134 | Todo lo que pusieron esta muy bien |
| 135 | Que tengamos mas piscinas para personas que necesitan terapias especiales tanto para tercera edad como general |
| 136 | Please offer children's swimming lessons that have a fixed duration with a single teacher, such as every day for one or two weeks. I don't want an ongoing commitment. I would rather sign up for a series of 4 or 8 lessons with the same teacher and pay for it all up front. I don't want ongoing charges. |
| 137 | Please keep them as they are. They are WAY better than when the city ran the pool. Current program is tried & true & FABULOUS |
| 138 | Would love to get a summer pass to use the lap pool and exercise. |
| 139 | It would be nice to have beginner adult swimming classes in my neighborhood "Bellhaven". But evening or weekend schedules. |
| 140 | *Space times open for family time *Times available for swim lessons *Most import - keep pool accessible to the community **"@times it felt the community never had access" |

All comments are shown as they were written and submitted by the respondents, and are numbered in the order they were received.

Q12. How important are the following athletic programs?

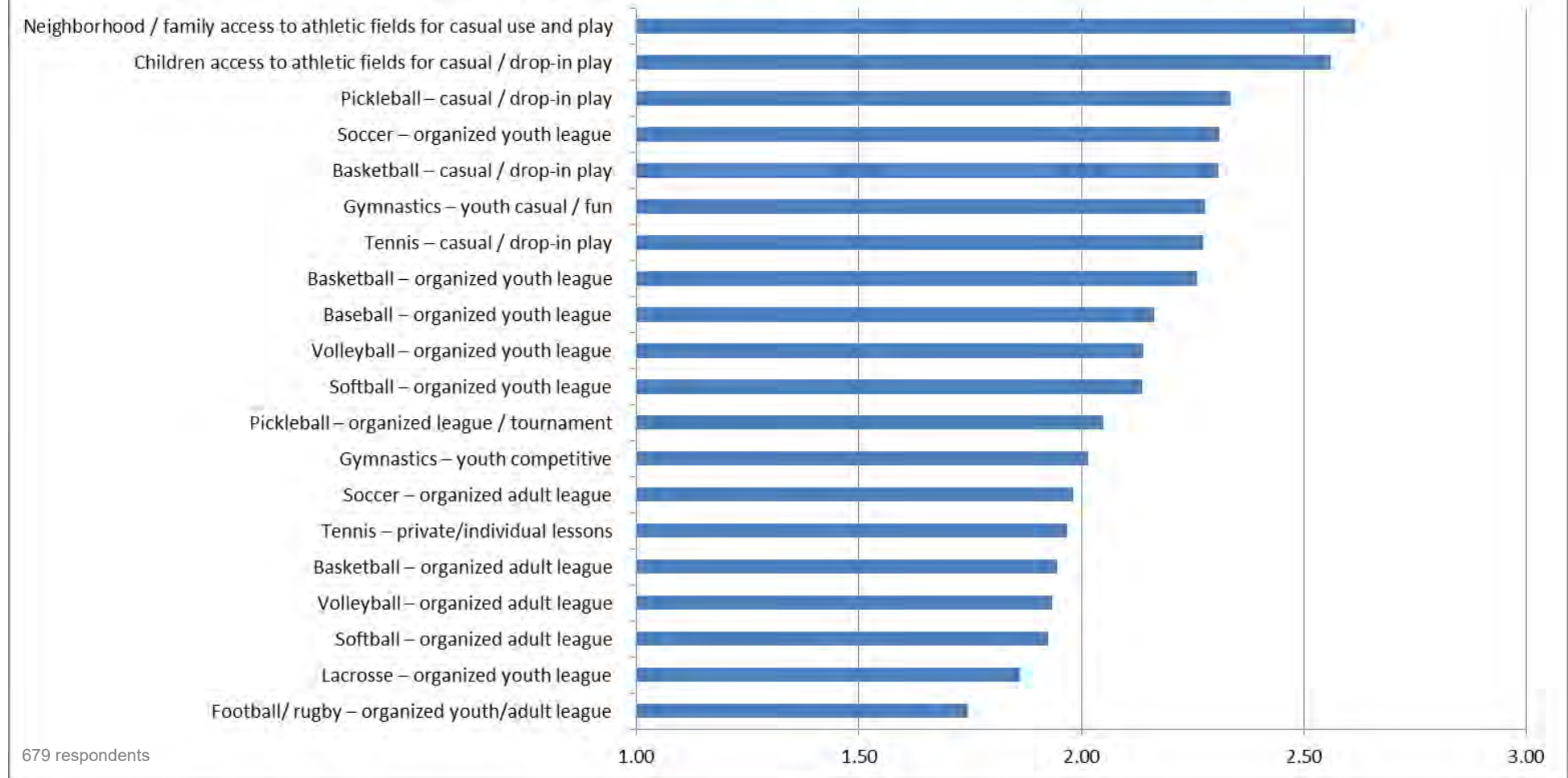

This chart shows average relative importance as rated by survey respondents. Respondents had the option to rate each item as either "not at all important," "somewhat important," or "very important." Items rated "not important" are assigned a value of 1; "somewhat important" a value of 2; and "very important" a value of 3. The chart shows the average value of all ratings for each item. Higher average ratings indicate higher relative importance to the survey respondents.

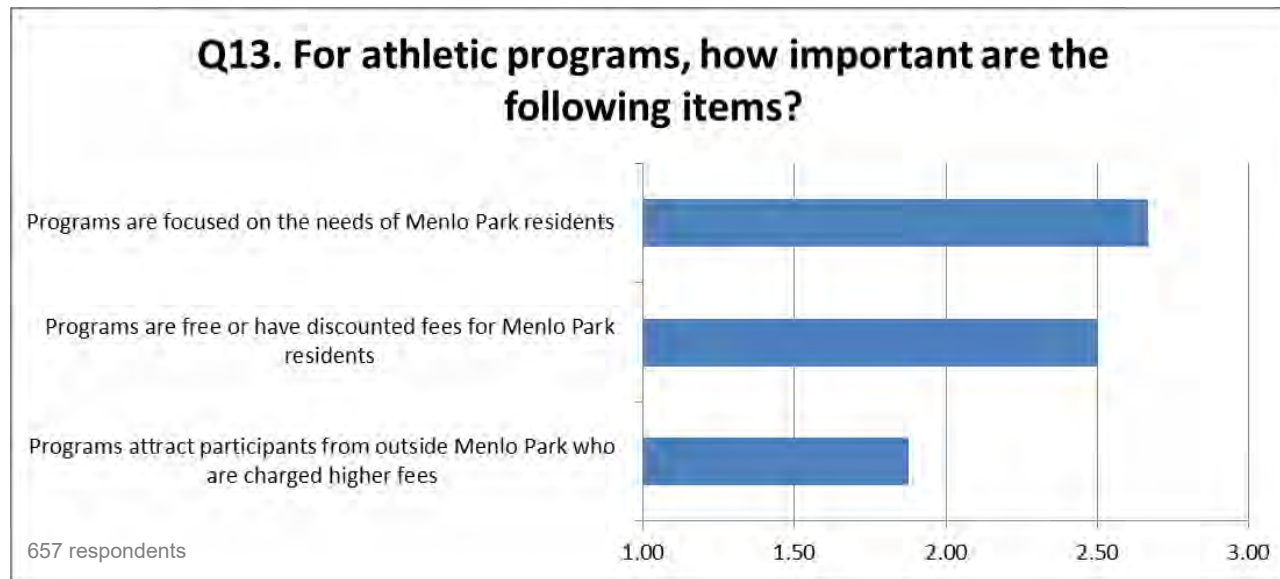

This chart shows average relative importance as rated by survey respondents. Respondents had the option to rate each item as either "not at all important," "somewhat important," or "very important." Items rated "not important" are assigned a value of 1; "somewhat important" a value of 2; and "very important" a value of 3. The chart shows the average value of all ratings for each item. Higher average ratings indicate higher relative importance to the survey respondents.

| Q14. Please tell us your ideas, needs, and suggestions for the city athletic programs. [#154889] | |
|---|--|
| 1 | More pickleball courts, particularly at Nealon Park. In short-term, please convert two more tennis courts into 6-8 temporary pickleball courts. Longer term, please create permanent pickleball courts in Menlo Park, ideally at Nealon (and/or Burgess). Pickleball is an excellent, space-efficient, social, multi-age, multi-skill, community-building sport. It is best to have courts together in one location to facilitate community and drop-in play. |
| 2 | Re-line more tennis courts for pickleball use. |
| 3 | pickleball needs better facilities - 1) more courts at Nealon - the hub of the existing community 2) better nets 3) dedicated courts or at least courts that are painted primarily for pickleball with tennis lines for secondary use |
| 4 | I would like to see 4-6 pickleball courts in a single area in Menlo Park. This will allow pball players to just show up when they want to play and find others of the same skill area to play with. In this way, a pickleball community will be created ala what is currently happening at Mitchell Park in Palo Alto where there are 15 pickleball courts at one site. The Palo Alto Pickleball club has >700 members |
| 5 | We need more pickleball courts!! ; More pickleball courts are needed- we have to wait for courts at Nealon all the time now. Four are not enough. Thank you . |
| 6 | Again we need to build a community for pickleball. Visit the courts in Palo Alto vs Menlo and note the amount of people playing. We need more and Permian to courts in a central location. |
| 7 | Menlo Park should offer pickleball classes for all age groups. To accommodate the explosive growth of interest in pickleball we need to increase the capacity of pickleball courts in our city, both in the very near term (e.g. converting more tennis courts for both pickleball and tennis usage) and long-term (e.g. more permanent dedicated pickleball courts). Pickleball is a very social sports that promotes the sense of community and a wonderful way for our residents physical and mental well being. For the immediate term I believe converting 2 tennis courts in Nealon Park for dual use of pickleball and tennis is a low-cost and effective way to address the pickleball community's need immediately. |
| 8 | Ensure that there are sports for children age 7 and older. |
| 9 | There's a huge community of pickleball players who are not being well served at the temporary courts at Nealon. There needs to be 2 tennis courts set aside to share so 8 pickleball courts can be available -- something that is needed and demonstrated by the large number of pickleball players each day. The courts need to be grouped, not spread around the city like tennis courts. The community that has been created and continues to thrive & grow needs a central place since one can show up solo to play anytime (unlike tennis). Day after day it's clear that there are far more pickleball players than tennis players there -- it's time to come up with a better solution. Please think about the community and make sensible decisions. |
| 10 | We desperately need additional pickleball court capacity, preferably at Nealon Park which has become the defacto hub of the pickleball community. |
| 11 | Short term conversion of 2 tennis courts to 6-8 dual use pickleball courts at Nealon Park Long term more and permanent pickleball courts at Nealon Park and possibly something at Burgess. |
| 12 | More pickleball courts. |
| 13 | There should be enough variety that kids have opportunities for participating in non-organized sporting activities or on a team and some variety for adults. Access to space and opportunities to play sports on a casual basis, like going to shoot baskets or use a reasonable sized grassy area to play informal soccer. |
| 14 | My husband has really enjoyed playing softball for the recreation league and my sons have been playing Little League. Sports is 3 to our family. |
| 15 | Keep it reasonable |
| 16 | - tennis courts should not be used for pickleball or other multi-use activities. They were built and designed as tennis courts and should remain. - tennis court access should continue to require an annual key |
| 17 | 2 additional mixed-use pickleball/tennis courts, dedicated pickleball courts in the future (across MP) |
| 18 | Open gymnastics classes |
| 19 | I much prefer true grass fields rather than turf. |
| 20 | Do not know much about city needs except as regards the pool. |
| 21 | Gymnastics programs for pre-competitive and fun. |
| 22 | Due to COVID, so much program opportunities were lost. It will take time to get programs up and running AND IT MUST BE A PRIORITY for the spiritual (yes, sports have a spiritual component) and cultural benefit of Menlo Park. ALSO, focus on the needs of Belle Haven to engage youth AND adults in recreational activities.; Soccer, dance, baseball, basketball, softball, gymnastics, pickle ball and flag football at appropriately sustainable levels would provide year-around opportunity for health and multi-cultural involvement of the entire Menlo Park community. |
| 23 | Let's add more pickleball |
| 24 | Please open the gym!! It's world class facility, but it's just sitting there closed. What a waste. There's no excuse when everything is open. Privatize it if you cannot find the staff. |

All comments are shown as they were written and submitted by the respondents, and are numbered in the order they were received.

| Q14. Please tell us your ideas, needs, and suggestions for the city athletic programs. [#154889] | |
|---|---|
| 25 | There are changing trends in sports engagement from when my kids played (swimming, soccer, basketball, volleyball) and I respect that but would hope to continue to support as much as there is interest in. I do believe we should support the school league needs (both my kids also coached younger teams) and inevitable community leagues require support of neighboring community teams for tournaments. |
| 26 | Equal fees all users |
| 27 | There is a huge demand for more pickleball courts at Nealon. We need more temporary courts as the four that have been designated are often full with a line while the tennis courts adjacent sit empty. It is really important to increase the number of courts at Nealon due to the social nature of the game; in other words, if you added more courts elsewhere in Menlo Park, that wouldn't necessarily help alleviate demand at Nealon as I think most players will continue to come to Nealon to be assured of having a wide range of players (and levels of players) to enjoy pickleball with. |
| 28 | Would love more pickleball courts |
| 29 | Pickleball is the fastest growing sport, encourages drop-in and family play. Menlo Park is not keeping up with the growth of this sport like some communities. We need more and dedicated Pickleball courts. |
| 30 | Convert more tennis courts for pickle ball use. |
| 31 | More pickleball courts to support the burgeoning number of Menlo Park pickleball players. |
| 32 | Pickleball is a fast growing sport and should be better supported in Menlo/Nealon Park. There have been previous meetings with residents and many suggestions for improvements. |
| 33 | Definitely need more pickleball courts throughout Menlo Park. Nelson Park could easily double from 4 to 8 courts. Perhaps even 12. |
| 34 | Focus on the needs for Menlo Park, and needs of the common resident |
| 35 | Please bring back gymnastics there is a need for it! |
| 36 | As mentioned above, I'd love to see the gymnastics classes of all kids open up again for kids. This is a huge loss for our city and residents. |
| 37 | We need more pickleball courts. The courts are extremely crowded and generally there is a wait to use the courts. Tennis courts near Nealon park are lightly used. |
| 38 | Need more Pickleball courts. It would be great to have a Pickleball only facility. |
| 39 | Need more accessible basketball courts, pickleball courts and drop in fields. Lack of open recreation fields which do not require kids to pay to be in league |
| 40 | MORE PICKLEBALL COURTS PLEASE!!! |
| 41 | Focus on Menlo Park residents. |
| 42 | Dedicate the current Nealon Park Tennis courts #3 and #4 to 8+ permanent Pickleball courts. Leave tennis court #5 as mixed Tennis/Pickleball, if courts #3 and #4 are dedicated to Pickleball, but in the meantime, dedicate court #5 to Pickleball until courts #3 and #4 can be converted. |
| 43 | We need more Pickleball courts in Menlo Park. Ideally there would be six or more dedicated courts at Burgess (Like they have at Mitchell Park). In the meantime, the city could add a lot more temporary courts at Willow Oaks Park, Burgess and Nealon. What makes Pickle Ball so special is how it brings community together and we can easily pick up a game. So the ideal situation would be a number (6, 8 or 10?) of DEDICATED Pickleball courts in the middle of the town - accessible to all, with a bathroom nearby. |
| 44 | need to have PERMANENT pickle ball courts, not just temporary ones set up on tennis courts. creates conflict between PB players and tennis players. |
| 45 | Dedicated pickleball courts and more dual pickleball/tennis courts |
| 46 | More pickleball capacity - more converted courts in Nealon Park, additional capacity in other parks |
| 47 | Physical fitness is really important, so thank you for supporting sports programs for children & adults. For me, my priority is pickleball. |
| 48 | More pickleball courts Nealon Park or Willow Road Dedicated or shared with tennis |
| 49 | Dedicated pickleball courts and develop a program within Menlo Park similar to Palo Alto and so many other citirs |
| 50 | Need more timely feedback from users. For example I have never had a survey from Menlo Park in the 7 years I have been using the pool until this survey. Why not send it to all participants at the end of every session or class throughout the recreation programs? The library has been remodeled twice during which time no major improvements or expansion has been made to the pool. Why? How did Cubberly in PA know to move to 21 pickle ball courts while Menlo Park just envelope 2 courts last year? It seems the sports programs are heavily male oriented. If one had better pool facilities then a more diverse program could be offered such as synronized swimming as an example. |
| 51 | please NO MORE PICKLE BALL COURTS |
| 52 | Convert more tennis courts to dual use pickleball courts |

All comments are shown as they were written and submitted by the respondents, and are numbered in the order they were received.

| Q14. Please tell us your ideas, needs, and suggestions for the city athletic programs. [#154889] | |
|---|---|
| 53 | More pickleball courts as this sport is growing so fast and there's not enough space to accommodate for all age groups that are playing. Please convert two more tennis courts at Nealon into dual use courts, into 8 pickleball courts to allow 32 pickleball players to use the same space that 4 tennis players use. |
| 54 | Have more pickleball courts. I have noticed that many times of the year the tennis courts are not being used. Could you please convert more tennis courts to pickleball courts? |
| 55 | I previously mentioned the need for more Pickleball Courts. Mitchell Park in Palo Alto has more than a dozen Pickleball Courts, and their popularity continues to rise. |
| 56 | I request that you create permanent Pickleball courts in Nealon Park and convert two tennis courts in the park to Pickleball courts. I play Pickleball there frequently, at different times of the day, and there are always tennis courts available, but not always Pickleball courts available. |
| 57 | Pickleball groups! |
| 58 | KEEP REVELANT TO COMMUNITES CLOSET THAT WILL USE THE CENTER AND INCLUSIVE |
| 59 | Local adult leagues (soccer, volleyball) would be great for my husband |
| 60 | More pickleball courts. Critical need. Fast growing sport and fun |
| 61 | Menlo Park School rec facilities should be made available for residents use when school hours are over. Atheltic tracks for example. |
| 62 | Make facilities available for drop-in or casual use should be highest priority. Next priority should be classes. Lowest priority should be competitive leagues |
| 63 | If local schools have league play for baseball, soccer, etc then these programs have less priority for the city to provide. |
| 64 | For older adults |
| 65 | Remember to leave time/space for casual play/use on all fields. Often people want a place to just toss a frisbee, toss a football, or do summersaults. When I walk past the park it's so nice to see everyone enjoying it, not just organized soccer teams. Give the parks back to the people. |
| 66 | 2 additional courts at Nealon Park need to be converted to dual pickleball/tennis usage. |
| 67 | Convert more tennis courts into pickleball courts |
| 68 | Pickleball is a rapidly growing sport and 2 additional tennis courts in Nealon Park should be converted to dual use for tennis and pickleball. |
| 69 | I'd love to see more pickleball courts, as well as organized play for Menlo park residents. It's a great way to build community within Menlo park. |
| 70 | Two tennis courts to be converted to dedicated pickleball courts |
| 71 | tennis courts in Nealon Park should be converted to dual use for tennis and pickleball. Would be nice to have them be Pickleball only but we can start with dual. but pickleball is definitely way more popular. we are there all the time. and there are so many of us and we are there all the time |
| 72 | PLEASE bring back the gymnastic program for kids. |
| 73 | More Pickleball courts |
| 74 | I would like to see at least 2 tennis courts in Nealon Park be converted to exclusive use for pickleball. Failing that, perhaps dual use for tennis and pickleball. |
| 75 | Pickleball is exploding around the whole Bay Area. The courts at Nealon Park should be made permanent and expanded to at least 8 lit courts. Because of the drop-in social nature of pickleball it is best to concentrate the courts in 1 or 2 areas rather than distribute them like Tennis courts. |
| 76 | It would be great if two more tennis courts in Nealon Park could be converted to dual use for tennis and pickleball. |
| 77 | There are so many Pickleball players playing at Nealon Park, that very often the 4 temporary courts located in tennis court #5 are full (16 people playing) and there are people waiting to play next. At the same time, courts #3 and #4 are empty or have at most 2 people playing. I would suggest converting tennis courts #3 and #4 into 6-8 permanent Pickleball courts (no sharing with tennis) and keep the temporary Pickleball courts in tennis court #5 shared with tennis, bt with priority to Pickleball if there are more than 8 Pickleball players waiting to play in courts #3 and #4. Courts #1 and #2 would still be dedicated to tennis and court #5 could also be used for tennis if courts #1 and #2 are full. |
| 78 | Over the years my kids have used participated in organized soccer, basketball and tennis programs and we have been very pleased with them |
| 79 | If the city's parks and recreation department can focus on opening up facilities rather than keeping facilities locked, then maybe we can start moving forward toward providing the tax payer a place to recreate. Allow local entities (clubs) to run your tennis and pickle ball, soccer, volleyball, and basketball leagues and socials instead of locking the courts. |
| 80 | Re-opening the gymnastics center and adding open practice time hours |
| 81 | need pickleball classes & more courts; n/a |
| 82 | Love to see More pickleball courts added or dual Tennis courts made available |

All comments are shown as they were written and submitted by the respondents, and are numbered in the order they were received.

| Q14. Please tell us your ideas, needs, and suggestions for the city athletic programs. [#154889] | |
|---|--|
| 83 | Again, offering pickleball classes for residents is a great way to introduce people to the game. |
| 84 | Pickleball courts!!! There is a current high demand and a super fast growing population. Kids through older adults. Amazing community experience. It MUST remain free for use! |
| 85 | More pickle ball courts are needed. They are full every time I go to play and the sport is gaining in popularity. |
| 86 | No suggestions other than survey responses. |
| 87 | Menlo Park's adult sport leagues are a whole lot of fun. I loved playing adult volleyball years ago, I don't recall us ever competing, but we did get coaching to improve our game. It was casual enough to include anyone willing to try, but serious enough that the games were well played. I hope the City continues providing sports opportunities that allow anyone to try out. |
| 88 | Expand pickleball program |
| 89 | Please continue to invest in the Belle Haven community. |
| 90 | Juggling time |
| 91 | I would like see more Pickleball permanent courts by Flood Park. |
| 92 | Pickleball |
| 93 | Stability, predictability with respect to facilities operations. I am willing to pay to participate. |
| 94 | It would be great if the gymnastics facility is reopened soon and is run as well as the Burgess pool. |
| 95 | continue to have professionals manage them |
| 96 | They should be based on fun, health & safety. Youth competitive programs belong in schools where there are more facilities and which are better funded. Semi professional athletes should NOT take up community facilities, especially to the exclusion of other members of the community. Too much emphasis at least with respect to the pool is placed on profit. Perhaps this is so with gymnastics and tennis and this is intimidating for ordinary people |
| 97 | We would like the gymnastics program to return. It was a place that we could always meet many of the kids at Menlo Park. It would also be nice if in addition to gymnastics there was another strong program or 2 I which residents are likely to meet their neighbors. Also would be nice to have more adult classes at various hours of the day (including everythings for working parents) |
| 98 | Hire professionals to make these decisions and let the residents deal with those decisions. Stop listening to the squeaky wheels and gather information on existing programs that are successful! |
| 99 | I'd love to see athletic competitions that splits the sexes. My daughter adores basketball but gets ignored in a coed team because it's usually all boys and this is so disappointing to her. Boys and girls play sports very differently and in the elementary ages separating them helps the experience a lot. My son who is 5 would prefer not to play with girls because his exuberance sometimes scares them. |
| 100 | I think they need to be restored to pre covid levels and service. City management has been derlict in the negligence of the recreation center and the restoration of programs. |
| 101 | I do not utilize these programs. |
| 102 | reservations for some tennis courts so that they're accessible for everyone and not just children/students |
| 103 | I put only organized sports as 2 because I feel these should be City leagues. With Menlo Park as the organizer. It is ok to have sponsors but the leagues are part of the city. Not AYSO, etc. |
| 104 | pickle ball lessons |
| 105 | Multiple questions have dealt with non-MP residents. I think non-MP residents should be charged a higher fee. But is the goal to purposefully entice them to come? To pay the higher fee? If the question is "Should non-MP residents be charged more?" then "yes". |
| 106 | I no longer have children that would use the athletic programs therefore suggest more senior programs if available |
| 107 | Please reopen the dog park on the baseball field! |
| 108 | Please include badminton |
| 109 | We need a permanent dog park in Menlo Park and the west side of El Camino. |
| 110 | Pickleball added every opportunity. It's an incredibly accessible and fun sport. Let's get courts included in the Flood Park renovation. Nelson park was a great start but mainly benefits just West Menlo in closer proximity. |
| 111 | Please bring back gymnastics. Please expand more pickleball courts. |
| 112 | None; Allow dogs off leash on fields during certain hours in the evening |
| 113 | While the sports resources should prioritize Menlo Residents, people from the surrounding community create enough demand to support programs like Swim teams, Masters and Sr. AquaFit. The pool brings people to Menlo Park and people in turn spend time in Menlo park shopping and eating out. I do more business in Menlo as a result of swimming several times a week |
| 114 | I would like to see the gym open again and Boot Camp reinstated. |
| 115 | Be grateful for the management you currently have!! It will never be better and a total loss if discontinued. |
| 116 | Softball for adults, gymnastics for kids |

All comments are shown as they were written and submitted by the respondents, and are numbered in the order they were received.

| Q14. Please tell us your ideas, needs, and suggestions for the city athletic programs. [#154889] | |
|---|--|
| 117 | The pickleball courts at Nealon are increasingly crowded. More pickleball courts would be appreciated. |
| 118 | PLEASE PLEASE We would LOVE to see the Arriaga Gymnastics class for toddlers/childrens come back. |
| 119 | Adult gymnastics is important for our household! |
| 120 | focus on residents! |
| 121 | It is so important that their is inclusion for all races and ages. |
| 122 | Pilates? |
| 123 | More pickleball courts |
| 124 | students sponsored for lead athletic capabilities |
| 125 | Keep up all sports, it is so important for health as well as social well being |
| 126 | More Pickelball courts |
| 127 | We need pickleball courts as the Palo Alto pickleball courts pre over crowded; We need pickleball courts as the Palo Alto courts are over crowded |
| 128 | Pickleball is getting so popular in the bay area. Need more courts in different cities that are open 7 days a week to lessen the burden at existing pickleball courts. |
| 129 | Significantly more dedicated pickleball courts needed! |
| 130 | More pickleball courts. Fast growing sport. Lots of fun. |
| 131 | More pickelball courts. Good for all ages. Please come and join. Good for your health |
| 132 | Pickeball league. And ladder. Pickleball pot luck. And fun days |
| 133 | I play pickleball three times a week and I enjoy the social, exercise and competition with others. It's a great sport and we need more pickleball courts in areas like Menlo Park and surroundings areas as well since the sport is the fastest growing sport in the U.S. |
| 134 | Additional multi court facility for pickleball, or fully expanding dedicated pickleball courts at Mitchell Park would go a long way in relieving stress on an already maxed out community gem! |
| 135 | More pickleball courts please. The tennis courts stand empty so many hours per day |
| 136 | pickleball is very popular now, please have more courts, so residents can join any level games |
| 137 | More Senior programs |
| 138 | ? |
| 139 | I have played in the past at Kelly Park Pickleball Courts, and now play a couple of times a month with Menlo Park residents at Nealon. Nice courts and facilities at Nealon, but at times they are overly crowded. It would be nice to have a few extra courts to allow for all who want to play and also those who want to drill. |
| 140 | More robust pickleball offerings benefit not just Menlo Park residents, but the surrounding areas. |
| 141 | We need more pickleball courts |
| 142 | I think larger fields would be better |
| 143 | Playground at Sharon Park needs to be bigger. |
| 144 | Basketball classes for kids |
| 145 | Would be helpful to have a magazine every month or app to show what activities are playing and the cost, time, date. |
| 146 | Belle Haven needs recreational programs focused on the needs of Belle Haven residents, not of outsiders who rent the only facilities we can get to and keep us from using them |
| 147 | Basketball gym in belle haven |
| 148 | -more easy access to facilities -more water bottle fountains |
| 149 | Supervision at All times maybe 2 1/2 hrs. If At All Possible |
| 150 | No fees should be charged for Atherton residents |
| 151 | We should provide priority of the user to Bellhaven residence |
| 152 | more advertisement of adult leagues |
| 153 | I hope priority will be given to athletic programs that are from eastern MP first. West MP has nice facilities already. |
| 154 | kid's soccer |
| 155 | over 40 & over 50 sports leagues. how about clinics to train officials |
| 156 | n/a |
| 157 | n/a |
| 158 | n/a |
| 159 | Having noncompetitive programs that focus on kids learning to play different sports and team culture. Having these youth programs be available for starting on weekdays no earlier than 3:45pm and to be completed by 7pm the latest. Having multiple weekend options. Having rec sports for kids <10 years old |
| 160 | muy inportante |
| 161 | N/A |
| 162 | Esta muy bien todo me gusta mucho |
| 163 | I like the girl's volleyball program in particular. Please continue that. |

All comments are shown as they were written and submitted by the respondents, and are numbered in the order they were received.

| Q14. Please tell us your ideas, needs, and suggestions for the city athletic programs. [#154889] | |
|---|--|
| 164 | Have Menlo Park have their own baseball, soccer, etc, competitive teams. |
| 165 | Look. People in the community need programs for community. There's plenty of community that will benefit from a lot of programs like the Midwest. We need more for our community |

All comments are shown as they were written and submitted by the respondents, and are numbered in the order they were received.

Q15. For city library and information resources, how important are the following items?

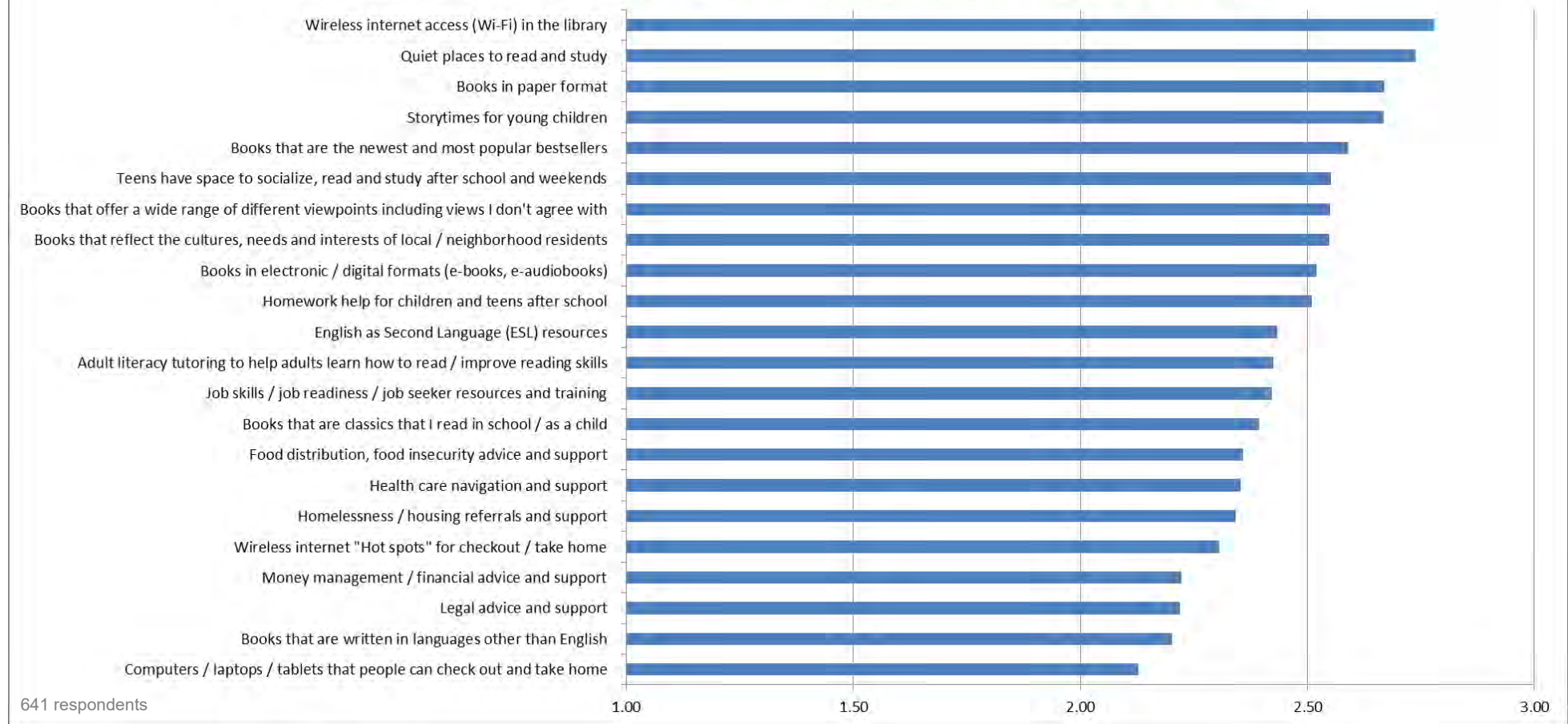

This chart shows average relative importance as rated by survey respondents. Respondents had the option to rate each item as either "not at all important," "somewhat important," or "very important." Items rated "not important" are assigned a value of 1; "somewhat important" a value of 2; and "very important" a value of 3. The chart shows the average value of all ratings for each item. Higher average ratings indicate higher relative importance to the survey respondents.

| Q16. Please tell us your ideas, needs, and suggestions for the city library and information resources | |
|--|---|
| 1 | If wifi isn't already available throughout all areas of burgess park, in my opinion it should be. I'd like to see an increased focus on providing access to digital assets. It is important to have a few devices (computers/tablets) available for checkout to residents for free but it would be interesting to do the math on the feasibility of a rental program. I would also love to see Stanford and Facebook (in particular but not exclusively) be required to provide access to libraries, computing resources and instruction as part of their development requirements. |
| 2 | These questions are confusing. Some of these services are important for residents like job readiness or food distribution but these are already provided by other community services organizations. Letting 3rd party providers use the library as a location to provide these services makes sense but the city does not need to hire staff to provide them. That would be duplicating other organizations that already have these resources. |
| 3 | I homeschool my family and we go to libraries. But the Belle Haven library is where we've been going previously. Mostly. But I don't feel like it's a city library. It is a school library. Make sure that the new library is welcoming for all and open regularly. I really like the city of Palo Alto library at Mitchell park. It has a nice kid section and is up-to-date with tech. |
| 4 | Homework support |
| 5 | - the library should not be the location of social services (while 3 including services for learning to read/write, ESL, food, homelessness). These should be provided elsewhere. The library should be what it is intended for; a place for books, reading, and children. Children's learning to read, access to books, safety, and exposure to positive individuals and role models at the library should be prioritized. |
| 6 | Not sure what the resources are that can address all of these issues. They all seem important. Certainly furnishing books, homework help, adult literacy, ESL, preschool book time are all important,. One would have to know a lot about other agencies meeting these needs to answer this question. |
| 7 | outdoor benches, spaces to gather outdoors near library. also community meeting rooms available. appreciate being able to donate books knowing it will benefit community/library services! |
| 8 | More resources for infant/toddlers- ie better facilities, better books, more interaction, etc |
| 9 | I feel that many of the services suggested under library are 3, however am not sure the library is the best venue for providing access. |
| 10 | We love the library and appreciate all it does. E-books, books, and quiet space are particularly important!; We love the library and everything it does. Don't change a thing — they're doing great work! |
| 11 | Larger library budget for hardback books, e-books, and purchase of CDs or streaming services |
| 12 | Leverage our resources to help support the growth & well being of our residents |
| 13 | I am answering that these activities are not important to me personally. I am 81 and childless. |
| 14 | Make the library a place that has many shelves of books again, widening the range of books for people of all ages to browse, use them for reference, etc. - a public commitment and encouragement for people to read and learn to read. This should include books on all the help topics listed above, as well as reference librarians who can help people find and use these books. |
| 15 | Food distribution, Health Care & Homelessness issues-housing referrals & support- These are all areas I was not aware were handled in our Library. I would think they would be handled in the City Hall. They are issues for sure- even here in Menlo Park, but I think they should be handled where there is more privacy for the individuals- they deserve respect just as much as any other person. |
| 16 | Please reinstate Project Read. Thank you for reinstating Conversation Club. |
| 17 | I have found it difficult to reserve e-books given long wait times. Given the popularity of kindle and similar devices, it would be great to put an emphasis on expanding access to borrowed e-books. |
| 18 | More after school youth programs, tutoring and study skills |
| 19 | Increase the offers of audio books (especially new ones) |
| 20 | More complete collections of current fiction. Less "let's promote these 20 titles" to virtue signal just how woke we are. Get over yourselves, you're a library, you shouldn't be carrying an agenda. |
| 21 | I used them constantly with my children when they were growing up. They are vital!!! |
| 22 | Rodent abatement & awareness |
| 23 | The ideological bent of the books is very far left. This does not respect the diversity of our area. Also, there are practically no non-fiction popular ebooks related to business or technology. I have tried dozens of titles and they are literally never there. This is Silicon Valley! When an Apple engineer writes a book about Apple, it should be available in our library! |
| 24 | Make Bellehave Library bigger |
| 25 | Focus on the needs of the communities closest to the center. |
| 26 | Would love more regular in-person teens events |
| 27 | Increase hours the library is open. |
| 28 | Food distribution, housing referrals, job skills, legal advice, money mgt are issues addressed by many other organizations. I do not see these as additional services to be provided by library. |
| 29 | I love our library and think adult literacy programs are 3. |

All comments are shown as they were written and submitted by the respondents, and are numbered in the order they were received.

| Q16. Please tell us your ideas, needs, and suggestions for the city library and information resources | |
|--|--|
| 30 | I used to visit the library frequently but stopped after sitting next to people who were there only to sleep. They snored really loudly and didn't bathe often. I also grew tired of asking people to keep their voices down. People often go to the library for a quiet place to read. It seems that a quiet library is a thing of the past, which is too bad. If I check out a book I take it home to read. |
| 31 | I didn't realize the library had all these amazing services. Are people taking advantage of them? Do they need to be promoted more? Regarding books in different languages, Spanish is a priority but other languages less so in print. Maybe those can be available electronically. |
| 32 | Offer more audio books and e-books, especially for newly released books. |
| 33 | Keep up the good work! |
| 34 | requesting books be transferred from other libraries takes a long time |
| 35 | Are there print for fee printers? |
| 36 | I love the library. I go there at least twice a week. I really appreciate the access to Link+ which brings books outside the system to me. I like being able to put movies "on hold." I have more than once suggested a book or film and had the request answered. I am worried that the librarians are being tasked with being social workers. I noticed an adolescent boy who seems to not be able to leave them alone and constantly touches things on their desks and asks them questions. I think the public restrooms in the library are important. I love the tiny space with books for sale. I think the "seed library" is a very original idea. The on-line programs hosted by John Weaver are a bonus. |
| 37 | We'd love to see higher quality Spanish children's picture books and early chapter books available. So many children participate in Menlo Park Spanish Immersion classrooms (about 40% of all children at Encinal and Laurel) and we need to offer better options for them to practice their reading skills, learn new vocab, and enjoy books in the language they are learning. Not just translations, rather books from native Spanish Speakers are ideal. |
| 38 | Community Meetings to talk with City Commissions / City Staff |
| 39 | -Programs that promote inclusion and diversity -Programs that address and dismantle institutionalized racist practices |
| 40 | #15 is hard to answer- it obviously depends on which branch and the communities being served. The librarians will likely have informed suggestions about what needs to be provided. |
| 41 | Agree with need for food/homeless/etc. support. Disagree that library is the place to provide those services. I stopped going to MP Library years ago due to a pattern of creepy approaches & unwanted attention from homeless men lurking near entrance. And stagnant air inside. |
| 42 | The breadth of services listed in this questionnaire is exciting and would make me inclined to spend more time at the library. |
| 43 | it would be great to have a space where visitors are allowed to talk away from the quiet areas. |
| 44 | i think WiFi and ebooks are a must - why are we questioning this? |
| 45 | In person story time for young kids on the weekends either in the morning (10a) or afternoons (4:30p) to avoid overlap with naptime |
| 46 | I would consider our family library super users, visiting 4-5 times a week with about 40 books out regularly and we sometimes attend events as well. As an involved person, I once applied to the library commission and was not accepted. Okay, but the person who was reached out to me at some point later to try and engage me through a typewritten letter to share she had gotten the spot and could we meet for a cup of coffee to chat midday. That experience was so strange to me since it felt like an old fashioned process and really turned me off from civic engagement and I haven't applied again. It worried me that the libraries didn't have a modern thought approach to services and didn't respect that some people who want to get involved have demanding day jobs and childcare to cope with, too. |
| 47 | More community events in the library |
| 48 | I hugely appreciate the activities and events for kids, especially in the summer. I rarely have time to go to adult events, given family and work obligations, but I love the fact that they are there and look forward to spending more time at events when the kids are older. |
| 49 | We are often looking for new children's books and series and they aren't available at MP. Would love to see more for growing chapter book readers. |
| 50 | It would be nice to have an enclosed patio of some sort close to the library with seating where people with pets or thing children could sit and read without fear of their kids or pets running into the street. |
| 51 | Can we do a childrens used book fair organized by book type? |
| 52 | The library was very slow to reopen to full time service to the community. Again, due to lack of city management oversight of services paid for by taxpayers. |
| 53 | So many San Mateo counties have been renovated or rebuilt for a modern era. Would be wonderful for Menlo Park to do the same. The Atherton and San Mateo libraries are just gorgeous and offer all kinds of opportunities for all ages. |

All comments are shown as they were written and submitted by the respondents, and are numbered in the order they were received.

| Q16. Please tell us your ideas, needs, and suggestions for the city library and information resources | |
|--|---|
| 54 | I never go in the library. I used to when my kids were needing to go in. There was a librarian I did not like so it was easier to stay away. With Covid I definitely will not be goin in. |
| 55 | The library cannot be all things to all people - for example, providing healthcare and legal support. These are important needs but beyond the scope of what the library should focus on. The library should focus on literacy, information access, and referrals to other agencies to handle homelessness, job skills, etc. |
| 56 | I noticed we no longer can print materials at the library and do think we need that capacity available when using checked out laptop to print material and copy machine is no longer at library and we should have that for convenience purposes. |
| 57 | Please increase the number of ebooks you make available to check out. All new books should come in both paper format and electronic format to check out. |
| 58 | More availability of ebooks |
| 59 | The library has excellent resources, the speaker series is especially strong |
| 60 | Continuing services as is. |
| 61 | Earlier opening times in the mornings would be helpful. |
| 62 | The social services could be housed in the rec. center or part of city hall |
| 63 | outdoor kids storytime |
| 64 | The library needs to be open earlier in the morning every morning. It needs more Spanish board books for the baby's and toddlers. The Spanish picture books and leveled reader selection needs to be expanded, more centrally located in the children's section, and displayed in a way that's easy for elementary school kids can access. Two of our elementary schools have 2 classes of Spanish Immersion for almost every grade, and the library should reflect that. |
| 65 | large book collection, audio selection. Nothing worse than a poorly stocked city library-- |
| 66 | Library staff should reflect the people who live in the neighborhood. It feels more acceptable and welcoming |
| 67 | Keep real books available. Have authors come visit |
| 68 | Please congratulate the head librarian on all the wonderful changes-lots of creativity. |
| 69 | It would be great to offload older books to a warehouse to be ordered and extra space could be used for conferemce rooms and maker / craft / DIY spaces |
| 70 | love the library book selection, love the bookstore |
| 71 | Community is getting older, more day-time programs for seniors will be great |
| 72 | Please keep the library open and full of librarians. we need this service |
| 73 | Toddler Storytime. More displays by topic in the children's area to help kids find books. |
| 74 | ? |
| 75 | more books would be better |
| 76 | There should be more mythology books |
| 77 | Maybe more graphic novels? Honestly everything is pretty good here |
| 78 | Extend the hours of Belle Haven Library. |
| 79 | Children reading programs |
| 80 | Maybe some type of activities for kids such as reading time |
| 81 | The Belle Haven Library should be open as many hours and offer the same resources as the Main Library. |
| 82 | Outside story time for kids in various parks. Pop-up library desks on sidewalks/hosted by neighbors |
| 83 | I'd like to have a place to study and read |
| 84 | Events for teens at the library just like on the west library |
| 85 | -more story-time for the kids! w/people who are animated as they read |
| 86 | If the city is working all of the resources on the previous page, Bravo to Menlo Park. |
| 87 | Belle Haven community needs a stand alone library and police station like at Burgess Park |
| 88 | No Idea |
| 89 | n/a; Love the libraries |
| 90 | I love the overdrive app for digital books! |
| 91 | Love the libraries |
| 92 | Bravo for maintaining library services during the pandemic! I appreciated the walkup window |
| 93 | Generally think libraries can be a valuable social/community resource and inclined to support & invest |
| 94 | I have never noticed legal/food/etc. services at the library |
| 95 | Open the library to the public all day |
| 96 | Offer volunteer hours for middle school & HS students for community service hours |
| 97 | An 'open 24/7' Library |
| 98 | Libraries are critical sources of public information and should provide not only the sources but access through literacy and language programs and up to date media. They should not take on the responsibilities of other public agencies/NGOs, such as food distribution, homing, legal and financial advice and outlets for socializing. |
| 99 | we would like to see the belle haven community more equitably represented with library services and access to the community pool. the belle haven library is appalling. |
| 100 | the library is great more kid's books in spanish & hindi |

All comments are shown as they were written and submitted by the respondents, and are numbered in the order they were received.

| Q16. Please tell us your ideas, needs, and suggestions for the city library and information resources | |
|--|---|
| 101 | I would love for the city library to continue and expand community conversations around tough topics as well as those of local interest. |
| 102 | all of the above are wonderful but can only be supplied on occasion. a good referral section could advise people as to where to go to get the help they need or outside speakers. It's not a soup kitchen or hospital |
| 103 | n/a |
| 104 | n/a |
| 105 | n/a |
| 106 | maybe have more hardcover book + paperback books for sale |
| 107 | youth classes to learn how to used digital printing, learn coding/scratch |
| 108 | todo bien |
| 109 | horarios extendidos para el verano |
| 110 | updated kid/children section/outdoor/patio to read relax. Coffee stand |
| 111 | Manterner libros de americalatinos |
| 112 | N/A |
| 113 | Lectura de algun libro para saber del tema del libro y como escribe el autor y saber interes que cauaz |
| 114 | Pues si pueden aser mas esta bien muy bueno |
| 115 | Please host more events for teens, especially art or craft themed events. And please make sure event times don't overlap with MPCSD school times and events. |
| 116 | More foreign language resources for youth/teens - graphic novels etc. in foreign languages (Chinese, French, German, Spanish) |
| 117 | I LOVE this library. Not sure who said it but "all you need is a library & a garden to be happy!" |
| 118 | Have the library open longer & on weekends. |
| 119 | cursos de computacion para saber usarlos en el hogar, trabajo |
| 120 | It's good the library is open 7 days/week if possible. |
| 121 | A book club or some organized gathering would be great. Also, have author night guest and/or staff hosted lead discussions. |
| 122 | I love the library! I selected "3" for every item which may not be helpful but everything the library does is important. The library should get all the resources it needs to do all of this and more. |
| 123 | The library is one of my favorite city resources! |
| 124 | This would be amazing to support community in a Midwest way with community centers |

All comments are shown as they were written and submitted by the respondents, and are numbered in the order they were received.

| Q17. Please tell us any other ideas, needs, complaints or suggestions you'd like to share with us. | |
|--|---|
| 1 | More open access pickleball courts. |
| 2 | The city should have a greater/tighter focus on Menlo Park residents quality of life. I do not feel that Menlo Park residents have benefited enough from the growth that many of us feel has been forced upon us. |
| 3 | Allow skateboarding in town streets. |
| 4 | There is a lack of transparency in the city's prioritization between tennis and pickleball courts. It seems the decision making has rested with one city staff without any accountability. Please open up the process and stop this one individual from imposing his personal bias for the whole community. Please have this individual take direction from the City Council and the Park and Recreation. Community. |
| 5 | Menlo Park should offer pickleball classes for all age groups. To accommodate the explosive growth of interest in pickleball we need to increase the capacity of pickleball courts in our city, both in the very near term (e.g. converting more tennis courts for both pickleball and tennis usage) and long-term (e.g. more permanent dedicated pickleball courts). Pickleball is a very social sports that promotes the sense of community and a wonderful way for our residents physical and mental well being. For the immediate term I believe converting 2 tennis courts in Nealon Park for dual use of pickleball and tennis is a low-cost and effective way to address the pickleball community's need immediately. |
| 6 | We desperately need additional pickleball court capacity, preferably at Nealon Park which has become the defacto hub of the pickleball community.; Please consider converting more tennis courts to dual use pickleball/tennis usage near term (this year) and adding additional permanent dedicated pickleball courts during the next capital planning cycle. |
| 7 | Coffee shop, local arts crafts for sale, farmers market in parking lot |
| 8 | I wanna make sure that our new building and programs are top-notch. Just because we live in the Belle Haven neighborhood does not mean that we should have lower quality things. I have always felt we are treated differently than the other side of 1 oh one. It shouldn't be that way. We are all Menlo Park and we should all have equal access. On top of that, take into account why many people live in Belle Haven and that's because, before at least, it used to be affordable. I want to stay in this neighborhood and be able to afford things. Our family is not well off like many other families who live right here in the peninsula. But we care very much about it and appreciate any and all improvements. |
| 9 | The library is good and the little Friends' store at the front door is wonderful |
| 10 | the loss of multiple weekly aquafit/aquawellness exercise classes has been devastating for my health and my ability to volunteer in the community. please find a new operator for the pool services who will improve/be committed to serving ALL ages of our community and not just high performance swimmers or master swimmers or kids lessons. |
| 11 | Can we get a magic bridge playground in menlo park? Traffic on middle ave is getting worse due to nealon park and new el camino construction. It is also especially dangerous to get in/out driveways when cars parked on side of road Santa cruz ave has become a big disappointment with dated stores, empty stores, and even dated look/feel. How do we gentrify it and make it on par with neighboring down towns? I absolutely love what Springline is doing wrt bringing in quality restaurants. How do we extend this to downtown? |
| 12 | I'd love more drop in time for basketball hoops for my daughter. Appreciate rec center can be rented for events. Haven't taken classes at the rec center since our kids were little. Really hope you'll return the pool to the families of Menlo Park as it was when we first moved here. |
| 13 | Make libraries places where people can find books to read and to come together for reading-related events, not community centers which can be addressed in other city venues. |
| 14 | Please increase the number of pickleball courts at Nealon. The demand will only increase. See rates across anywhere in the nation for this evidence. Menlo Park needs to be ready for this increase in demand and it is currently not meeting the existing demands at Nealon. |
| 15 | There are far more people playing pickle ball at Neelon Park than there are tennis players. Permanently converting 1 or 2 tennis courts to pickle ball would better serve the community |
| 16 | Please make the pickleball courts at Nealon Tennis court 5 permanent for pickleball. Please draw pickleball court lines for tennis courts 3 & 4 so it can be a multi-use facility. Purchase new rollable pickleball nets for those two courts. Thanks. |
| 17 | I have found it difficult to reserve e-books given long wait times. Given the popularity of kindle and similar devices, it would be great to put an emphasis on expanding access to borrowed e-books. |
| 18 | Also the playground at nealon is not holding up well and large chunks are taken up by equipment that isn't able to be used |
| 19 | I prefer the library to remain primarily as a quiet space for books and book users. All the ancillary services being considered should maybe be downstairs so library patrons aren't crowded out by a lot of others services that have nothing to do with reading and studying. Why does the library have to provide services that are available elsewhere- like at food banks and etc. |
| 20 | Dedicated Pickleball courts. |

All comments are shown as they were written and submitted by the respondents, and are numbered in the order they were received.

| Q17. Please tell us any other ideas, needs, complaints or suggestions you'd like to share with us. | |
|---|---|
| 21 | Pickleball adoption is increasing at an exponential rate, while tennis court usage is extremely low. We urgently need permanent Pickleball courts at Nealon Park. We should permanently convert tennis courts #3 and #4 to 8 Pickleball courts (for exclusive Pickleball usage). We should also give priority to Tennis on court #5 if courts #1 and #2 are in use, otherwise court#5 can be used for Pickleball (keep the 4 temporary Pickleball courts in court #5 as well). This would give us 8 permanent Pickleball courts and 4 temporary ones (shared with tennis). Based on current Pickleball adoption and low tennis adoption, this would be a win-win for the community. |
| 22 | Convert tennis courts to pickleball courts since the demand for pickleball far exceeds that of tennis |
| 23 | request the permanent conversion of courts #3 and #4 to pickleball (keep court #5 for dual usage) |
| 24 | Please increase Pickleball access - first with temporary courts at Willow Oaks, Nealon, Burgess, then in a centralized place like Burgess with permanent courts. |
| 25 | Thank you for all your hard work to provide community services for Menlo Park residents. I have lived here for 27 years and have used the parks, libraries, pools, and pickleball courts the most. Currently pickleball is my priority. Thank you! |
| 26 | Rodent abatement, management. Owl box program. Fees to developers disturbing rat nests, rodent sanitation considerations in new development garbage areas More pickleball courts, dedicated or dual with tennis Nealon Park or Willow Road Thanks! |
| 27 | The city could do a better job of publicity when new rec sessions are starting since you no longer send out catalogues. Why not send link to those of us signed up for swimming registered users? Was recreation surgery sent to every Menlo Park household? Has a phone survey ever been done for recreation programs? |
| 28 | Convert Nealon Park courts #3 and #4 to permanent pickleball courts. In addition keep #5 dual purpose. |
| 29 | More access to pool for lap swimming, aquacise classes in the evening/night and mire pickleball courts |
| 30 | Please add more pickleball courts to accommodate for the community's needs. Short term: convert two more tennis courts into dual use courts. Long term: dedicated courts. Thank you! |
| 31 | I want to play pickleball with my friends after school. Please add more pickleball courts at Nealon. |
| 32 | Please create permanent Pickleball courts in Nealon Park and add some courts -- four temporary courts are not enough! |
| 33 | My family is just getting into pickleball and we'd like to see more courts. The tennis courts at Nealon are empty while crowds wait for pickleball courts. |
| 34 | Name rooms after community folks and make it culturally relevant to local residents, hire local residents and be aware what locals want. Reach out to local Boys and Girls/ YMCA and collobarate . |
| 35 | Children's storytimes have historically been quite crowded. Can there be more of them? |
| 36 | Permanent conversion of courts #3 and #4 to pickleball courts. Keep court #5 for dual usage. |
| 37 | More pickleball courts please |
| 38 | Increase the number of printed magazines. |
| 39 | I'd like to see dual tennis/ pickleball on more courts at Nealon park. |
| 40 | I'm surprised there was no mention of the duck pond at Burgess Park. I love walking past the duck pond but am saddened by the people who abuse it. The vegetation has been trampled, making it more difficult for the ducks to forage for food. I often see children abuse the ducks by chasing them and throwing rocks/stones at them. Many of the ducks seem to be a hybrid species that can't fly. When children are running after them they can't fly away. It must be very distressing. I also see people treat the duck pond like their private pool, bringing lounge chairs that they sit in all day. They've worn out the grass near the pond. Please take more care of the pond and ducks who depend on it. Signage encouraging respect for the wildlife would help. Also a person from the city patrolling, keeping people in line. Also signs that tell visitors to stay on designated paths and not trample on the vegetation. Please take better care of the ducks and the pond. |
| 41 | Convert more tennis courts into pickleball courts |
| 42 | Please add more pickleball court capacity. Courts can be dual use in the short term, but with growing demand dedicated courts in the longer term. |
| 43 | Dedicated pickleball courts! |

All comments are shown as they were written and submitted by the respondents, and are numbered in the order they were received.

| Q17. Please tell us any other ideas, needs, complaints or suggestions you'd like to share with us. | |
|--|---|
| 44 | <p>Pickleball is overrun with people. We need more space. We seem to have one person in management who is against pickleball. Sean has all the power and he's against it. It's frustrating since all evidence points to a future of pickleball. He makes unilateral decisions. Ugh. His reputation precedes him. Would be nice to have someone else in charge of this program. We have been waiting for over two years. He has cost the city a lot of money, making decisions that are not moving things forward. Kelly Park was all Sean and it was an unmitigated disaster. Well except for the people who go out there an teach. They know they can go out there because no one else goes out there.</p> <p>We were on course to make a decision to talk about putting lines down on the middle two courts so we would have 8 pickleball courts and Sean single handedly tabled it, saying we need to see what happens in the Willows Project -- which would be another two or so years.</p> <p>It would cost less to line 8 courts at Nealon than Sean paid to line the courts at Kelly. He doesn't know who to call. He needs to let people who know be in charge. He wastes so much money. He overpaid by over 2 times for the lines he okay'd for Kelly. And he chose black lines. Such a waste. Heart might be in the right place, but unfortunately he is the wrong person to be in charge. The parks and rec commissioners seem to all be on board and ready to go and then he pulls the rug from underneath them and us.</p> |
| 45 | More Pockle ball courts |
| 46 | I would like to see more pickleball court capacity: dual use on existing tennis courts near term, and dedicated courts longer term. Pickleball is the fastest growing sport in the US. Please add more capacity ASAP, so Menlo Park will not fall behind in planning to accommodate the growing number of players. |
| 47 | Additional pickleball courts would be great, even if it's dual use on existing tennis courts until dedicated pickleball courts are built. |
| 48 | Pickleball has become wildly popular and provides a much better usage of public space than tennis. Very often all 4 temporary Pickleball courts in tennis court #5 at Nealon Park are fully utilized, with several people waiting to play. It also allows multiple generations to socialize and play together. People in the community get to know each other playing Pickleball. This is never the case with tennis and we often see only 2 people playing in the other 4 tennis courts (#1 through to #4), while the Pickleball courts are packed. We should convert Nealon Park courts #3 and #4 into 6-8b permanent Pickleball courts and leave tennis court #5 as a shared court with tennis, but unless courts #1 and #2 are full, and courts #3 and #4 are not full, court #5 can be utilized for tennis. |
| 49 | More pickle ball courts, please! |
| 50 | The Parks and Recreation Commission serves no other purpose than to inform the city counsel of community needs. If it's just another committee gathering information without any decision making power, what would be the point of having this committee? |
| 51 | You should permanently convert Nealon courts #3 and #4 to pickleball, and use court #5 for dual usage. Pickleball is a much better use of space than the tennis courts -- 4X the number of people can play, so better value for the community. |
| 52 | pickleball has become very popular and there currently are no classes in MP, with limited court time. I have to go to Sunnyvale.; n/a |
| 53 | I would like to request the permanent conversion of courts #3 and #4 to pickleball in addition to court #5 being kept for dual usage |
| 54 | At Nealon Park, please consider permanent conversion of tennis courts three and four to pickle ball courts in addition to Keeping Court, #5 available for dual usage. Thank you! |
| 55 | I'm very happy to live in Menlo Park, I live modestly. I would like to see homelessness end. |
| 56 | Thank you for taking feedback . |
| 57 | <p>LOVE the no parking on street at night law, please keep it!</p> <p>What is your pest management plan, applicable to rodents? All the development will stir up rodent activity. Owl box program?</p> <p>Native plants only in new development? Plant milkweed? . . . Right, larger issues at hand.</p> <p>Water security - how will all the future water needs be met with this large escalation in residential development?</p> |

All comments are shown as they were written and submitted by the respondents, and are numbered in the order they were received.

| Q17. Please tell us any other ideas, needs, complaints or suggestions you'd like to share with us. | |
|---|---|
| | <p>I'm a Menlo Masters swimmer who moved to this area (Belle Haven) bc of Menlo Masters at Burgess. Prior to moving here and during COVID shutdowns, I continued paying full team dues when the facility was closed. If permitted, I would have continued paying in full during the entire shut-down to help ensure the costs of running the pool and paying staff were covered. As a Masters swimmer, I can say that Menlo Masters was the only team running in the Bay Area for several months, the facility was run in a safe, orderly manner. Pool access was fair and reasonable -- for Menlo Masters lanes we had to sign up at midnight, a horrible time slot that's equally bad for everyone, which I thought was fair.</p> <p>As recently as this summer, the performance pool was shut down for maintenance and I am so impressed by how the competition pool adjusted to address the needs of performance pool users. The swim team consolidated lanes to accommodate lap swimmers (swim practice lanes were crowded and I was fine with it), pool temp was warmer to also accommodate lap swimmers/aqua-robics/PT. We were advised that lap swimmers come first, as they should. When practice is over, we are instructed to immediately get out to ensure the lap swimmer has access and I personally have had only positive encounters with lap swimmers at this pool.</p> <p>To my knowledge, based on conversations with lifeguards and administrative staff - Tim Sheeper treats his employees well and he has a loyal base of lifeguards, which is essential during the lifeguard shortage we are experiencing throughout the US right now.</p> <p>The hours of operation have been accessible - I have tons of pool access as a resident and masters swimmer. The stability of this pool is unmatched - I have yet to be on a team where I can confidently rely on staff showing up, clean facility, pool being open and in working condition, and having a nice experience with the folks who attend.</p> <p>It is my understanding that the city wants to renew Sheeper's contract on an annual basis; however, I don't think that is a helpful approach- short term contracts create uncertainty; they lack the time or stability necessary to develop a solution to existing problems (i.e. the accessibility issue is anecdotal at this stage, a multi-year contract will facilitate the creation of data/ tracking needed for crafting a solution to this problem, such as developing programs that directly address the concerns and it's worth noting that Tim is well-connected enough to obtain resources needed to address). Short-term contracts adversely impact employee stability/morale and also can confuse residents if there is ownership change/different tone at the top. I see that 5-years may be too uncomfortable, perhaps 3-year could be a compromise?</p> <p>Please feel free to contact me if there's anything I can do to persuade Menlo Park to keep Tim Sheeper in charge of operations of Burgess. I am not exaggerating when I say that this team, this facility, is what attracted me to buy my first</p> |
| 58 | |
| 59 | My biggest concern is why is the city council discussing the Burgess pool management/program since it is the facility that attends most of the residents with excellent programs for all ages, instead of is focusing on how to replicate the same success in the gymnasium? |
| 60 | The idea that you are even soliciting complaints is very telling. Hire the best professionals. Let them do their jobs Pay them well with these taxpayer dollars. We can afford to do that in one of the wealthiest counties in the country. Listen less to those who complain and survey more often your satisfied residents. |
| 61 | I read some place that libraries are one of the few remaining public spaces where people are allowed to just be. I think it's important to preserve libraries as just that. |
| 62 | More dedicated dog parks, and dog parks with seating for the humans please and water fountains for both pups and people. Also grass, fake or otherwise is much better for pets and owners alike. Secondly, a park similar to the Magic Bridge in Palo Alto with structures and play items that have children with limited abilities in mind would be wonderful. |
| 63 | The current controversy over the pool management is unfortunate and does not inspire confidence in city management. |
| 64 | For a city of Menlo Park's caliber - our parks are dirty, our fields sub par. Would be wonderful to see these restored and higher maintenance standards given we have so few we should take good care of them. Some new landscaping/drought tolerant in the downtown parks especially the park across from Draeger's that hosts concerts and city events would be wonderful. Keeping the sidewalks more clean downtown would also be lovely. |
| 65 | Nothing else to comment on since I stated it earlier in the survey. |
| 66 | Addition to survey previously sent: So very disappointed to learn about the removal of >60 old and healthy trees to make way for the Flood Park development, with another >30 to be removed later. You really don't get it, do you? Why are so many fertilized, watered, pesticided large playing fields needed? Old trees, all trees are far more important. Menlo Park is a Tree City? Shameful destruction of CO2 trapping ecosystem and oxygen producers for no good reason other than selfish human profit. Same comments for SRI development, as we dive into drought. Don't worry, the status quo may last your lifetime . . . not your descendants, though. |
| 67 | The woodchips at the willows dog park prevent the dogs from playing well together since the dogs do not like to run on the chips. If we could figure out another solution for dogs to have grass or turf access in the evenings that would be better. Also there is no water fountain for the dogs in the Willows dog park. |
| 68 | Not enough classes for kids (4-12) on weekends |

All comments are shown as they were written and submitted by the respondents, and are numbered in the order they were received.

| Q17. Please tell us any other ideas, needs, complaints or suggestions you'd like to share with us. | |
|--|--|
| 69 | See above |
| 70 | I encourage people to look at the complexity of running a solvent aquatics program. Very few municipal pools are able to cover their operating costs. Menlo has found a model which allows that where incentives are in place to make the best and highest use of the facility and deliver the best customer service. The pool requires significant ongoing hiring for seasonal employees and part time employees, a registration and billing system, a website and IT behind the integrated technologies, customer service, safety and compliance considerations and ongoing marketing. This is a significant enterprise that has been built over time to serve the community and is not easily replaced. The existing program is flexible and adaptable to the community needs and continues to operate with the community in mind |
| 71 | I have been very happy with the programs offered by the city (with the exception of programs cut because the gym is closed). Please don't change anything. |
| 72 | I wish the Menlo Park library would integrate itself into a sharing system with the San Mateo County library. Its' very frustrating to see items in the catalog that aren't available to me as a Menlo Park resident. |
| 73 | add more sports, fix liebsity (for mobile), for cpearity. |
| 74 | Stop sending me stuff in Spanish--may I have things sent in English please? |
| 75 | Library can organize global student book exchange programs w/ other libraries around the world. This is a richer community so can attract revenue |
| 76 | y ou are doing a great job |
| 77 | Filling this out for Pickelball. More public courts are needed. |
| 78 | It's great when courts are able to support either tennis or pickleball! |
| 79 | More pickleball courts. |
| 80 | Pickleball is great for all ages; low barrier to entry; intersections across political and socioeconomic groups; |
| 81 | ? |
| 82 | Pickleball serves not just Menlo Park residents, but the surrounding areas as well! Playing with our neighbors from the Peninsula is good community building for all! |
| 83 | nothing |
| 84 | Make sure Belle Haven is given similarly resourced library & rec. access given the influx of new residents w/ high density housing. |
| 85 | More outside (outdoor) community events to make neighbors meet each other. Organizing camp out at a park with a program about stars or planets for example. Programs to help people grow food in their yards instead of grass. |
| 86 | Replace one of the corner markets on newbridge or ivy to a safeway or trader joes. Fix the light on ivy, it takes so long to turn green. |
| 87 | -Open up a more grand inclusive way to public art. We have a lot of kids that are shy to share. The Sunset fest was always a good escape. |
| 88 | Make sure there is Always a cross guard for the children, going to and from school. Keep it safe |
| 89 | n/a |
| 90 | The San Mateo Library system is truly outstanding! |
| 91 | Tree trimming, especially in East Menlo |
| 92 | A proper dog park is needed in the Belle Haven area |
| 93 | Menlo Park needs a larger dog park with grass or turf. The small parks with dirt/rocks/mulch/etc. are not good enough. |
| 94 | Thank you for undertaking this survey |
| 95 | Organized adult trips/tours would be nice. More music and poetry programs. One day workshops for folks who can't do long classes. More life skills-type classes (budgeting, investing, saving) |
| 96 | Build a better library. Surrounding cities have new libraries with multi-purpose spaces & are bright and cheery, the main library is a morgue |
| 97 | That the Belle Haven neighborhood have the same opportunities as Menlo Park residents |
| 98 | -It would be nice to have a ping pong table -another pool table -variety of classes, other activities |
| 99 | For the street cleaners, I thank you. Hope this will continue sometimes. |
| 100 | For the new Onetta Harris Facility, I hope that the residents that live in the Belle Haven Community will have priority over Western MP residents. |
| 101 | The Belle Haven Library doesn't print images anymore. I shouldn't have to pay for parking tickets to park in front of my apartment. At least for the people who have minimum of one parking space. |
| 102 | I hope that our library has reviewed and strengthened protections against discriminatory book ban requests. Book talk book club (or recommendation wall with optional pics of recommender with book) |
| 103 | Love having the east menlo sr. center this side of the freeway + open. Most beneficial for many. Wish it would stay. |

All comments are shown as they were written and submitted by the respondents, and are numbered in the order they were received.

| Q17. Please tell us any other ideas, needs, complaints or suggestions you'd like to share with us. | |
|---|--|
| 104 | I love the library + classes at the center encourage groups to use the facilities for their galas, parties, meetings as an extra source of income |
| 105 | n/a |
| 106 | n/a |
| 107 | n/a |
| 108 | having hard time to get housing (subsidized housing for seniors) |
| 109 | todo bien |
| 110 | libros para personas mayores |
| 111 | N/A |
| 112 | Que ofrescan un group de libros (5) y dejar que los leeve a la case y luego un breve disenro de lo leído para despertar mas interes por leer. |
| 113 | Todo esta bien |
| 114 | Programer curso de ingeles, tanto para principates como para perfrcionalo |
| 115 | It'd be great if there's a place for people to make book suggestions. |
| 116 | mas cajas postales mas postes de luz en la noche plantar mas arboles |
| 117 | *The free shuttle *Wish there were lighted tennis courts in Bellhaven area. Thank you for removing those white posts along Newbridge, they were a bicycling hazard. |
| 118 | Spread the word more so that everyone knows what is out there |
| 119 | We don't need more buildings in or around our community. |
| 120 | So much of this recreation and programming is excellent and it's hard to choose between them. If you need more money to support these wonderful things, you should take it out of the Menlo Park Police Department budget. |

All comments are shown as they were written and submitted by the respondents, and are numbered in the order they were received.

An architectural rendering of the Menlo Park Community Campus. The drawing shows several modern, multi-story buildings with large windows and flat roofs, interspersed with lush greenery and trees. A parking lot with several cars is visible in the foreground. The overall style is a detailed line drawing with some shading to indicate depth and texture.

MENLO PARK COMMUNITY CAMPUS

SUSTAINABILITY OVERVIEW JUNE 22, 2022

CITY OF MENLO PARK
META PLATFORMS
HART HOWERTON
PAE ENGINEERS
DCI ENGINEERS
KPF ENGINEERS
STOK
OPTONY / ENGIE SA



Menlo Park Community Campus | Final Planning Submittal Rendering - Arrival

HART HOWERTON



Sustainability

The City Council declared a climate emergency committing to accelerating actions to address climate change at a local level and adopted a 2030 Climate Action Plan with the bold goal to be carbon neutral (zero emissions) by 2030. The Sustainability Division leads and/or supports implementation of the Climate Action Plan within the organization and the community at large.

Currently, there are six Climate Action Plan strategies:

- **Electrify 95% of existing buildings**
- Increasing electric vehicle usage and decreasing gasoline
- **Expand access to electric vehicle charging** for multifamily and commercial properties
- Reduce vehicle miles traveled by 25%
- **Eliminate the use of fossil fuels from municipal (city) operations**
- Develop a climate adaption plan to protect the community from sea level rise and flooding



MENLO PARK COMMUNITY CAMPUS

Key Project Sustainability and Resilience Goals

All Electric, Zero Combustion, Net Zero Energy Project

USGBC LEED Platinum Certification

On Site Renewable Energy Generation

Naturally Daylit Spaces

Healthy and Sustainable Materials and Finishes



SamTrans Corridor

PROPERTY BOUNDARY

EXISTING REDWOOD CARPORTS WOULD REQUIRE REMOVAL OF 2 MONUMENT TREES

BLEACHERS BELOW TO REMAIN

Kelly Park Track & Field

NEW 3-STORY MENLO PARK COMMUNITY CAMPUS BUILDING

PG&E Substation

Terminal Avenue

- | | | |
|--|------------------------------|-------------------------------|
| A Menlo Park Community Campus Building | F Bicycle Parking | K Parking Lot |
| B Boardwalk | G Outdoor Dining Terrace | L Pool Area |
| C Playground | H Community Terrace & Garden | M Samtrans Bus Stop & Layover |
| D Existing Redwood Trees to Remain | I Service Area | N Fire Access Lane |
| E Children's Outdoor Courtyard | J Pedestrian Pathway | |



1" = 60' at 11" x 17"
October 8, 2021

HART HOWERTON

Proposed Site Plan

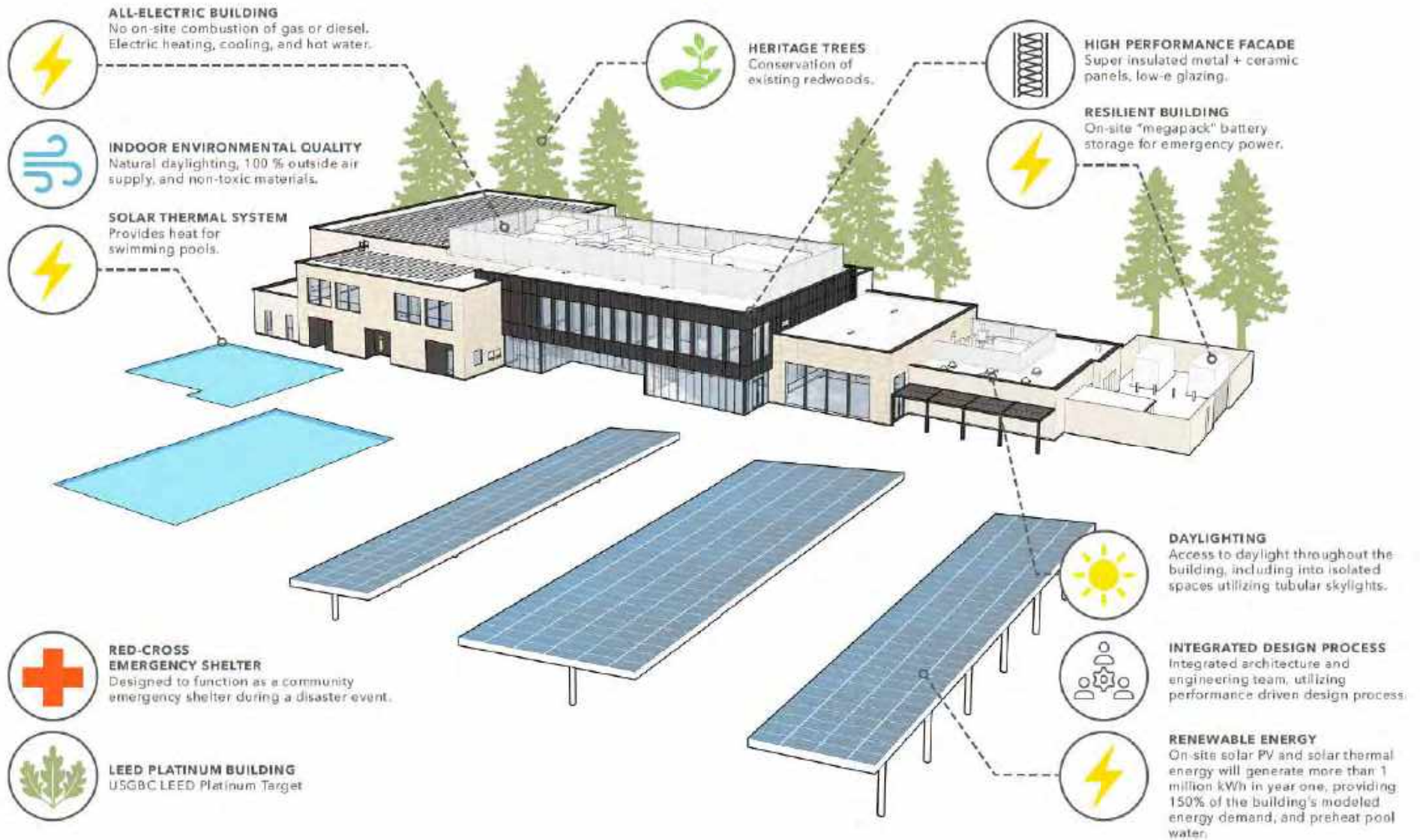

A Sustainable and Resilient Community Campus

HART HOWERTON

stōk LEED NC v4 SCORECARD

Menlo Park Community Campus

| AWARDED | LIKELY | PURSUIT | NO | Phase | Credit Name | Points Available |
|----------------------|--------|---------|----|-------|--|------------------|
| 1 | 0 | 0 | 0 | 0 | Credit Integrative Process - In design phase, achieve synergies between building, energy AND water related systems | 1 |
| Totals 1 | | | | | | |
| 0 | 1 | 16 | 0 | 0 | Credit LEED for Neighborhood Development Location - Locate within LEED ND certified development site boundary | 16 |
| 0 | 1 | 0 | 0 | 0 | Credit Sensitive Land Protection - Develop on previously developed land or follow criteria for non-sensitive | 1 |
| 0 | 1 | 0 | 0 | 0 | Credit High Priority Site - Locate project on infill location (historic district, priority designation or brownfield) | 2 |
| 2 | 0 | 0 | 0 | 0 | Credit Surrounding Density & Diverse Uses - Site within 1/4 mile of surrounding density criteria and/or a 1/2 mile of diverse uses | 5 |
| 0 | 1 | 0 | 0 | 0 | Credit Access to Quality Transit - Locate functional entries within 1/4 mile of existing transit or 1/2 mile of planned transit services | 5 |
| 0 | 1 | 0 | 0 | 0 | Credit Bicycle Facilities - Provide a bikeway, and storage areas | 1 |
| 0 | 1 | 0 | 0 | 0 | Credit Reduced Parking Footprint - Don't exceed minimum local code requirements for parking capacity | 1 |
| 0 | 1 | 0 | 0 | 0 | Credit LEED v4.1: Electric Vehicles - 5% of spaces or 25% discount for parking and electrical charging OR liquid, gas or battery facilities | 1 |
| Totals 0 1 16 | | | | | | |
| REQUIRED | | | | | | |
| 0 | 1 | 0 | 0 | 0 | Prereq Construction Activity Pollution Prevention - Implement an erosion control plan, per the EPA OGP v2012 | NA |
| 0 | 1 | 0 | 0 | 0 | Credit Site Assessment - Complete site survey including: topography, hydrology, climate, vegetation, soils, human use, human health | 1 |
| 0 | 1 | 0 | 0 | 0 | Credit Site Development - Protect or Restore Habitat - On-site restoration OR financial support | 2 |
| 0 | 1 | 0 | 0 | 0 | Credit Open Space - Provide outdoor space/water that is equal to 30% of total site area, 25% of which is vegetated | 1 |
| 2 | 0 | 0 | 0 | 0 | Credit Stormwater Management - Manage runoff for at least the 98th percentile of local rainfall events | 3 |
| 2 | 0 | 0 | 0 | 0 | Credit Heat Island Reduction - Meet rooftop and curb criteria OR provide a minimum of 75% parking spaces under cover | 2 |
| 0 | 1 | 0 | 0 | 0 | Credit Light Pollution Reduction - Backlight/night glare method calculation method, exterior luminance and signage req's | 1 |
| Totals 7 1 2 | | | | | | |
| REQUIRED | | | | | | |
| 0 | 1 | 0 | 0 | 0 | Prereq1 Outdoor Water Use Reduction - Permanent non-irrigated landscape OR reduce water use 30% for peak water month | NA |
| 0 | 1 | 0 | 0 | 0 | Prereq2 Indoor Water Use Reduction - Reduce aggregate water use by 30% or fixtures and fittings | NA |
| 0 | 1 | 0 | 0 | 0 | Prereq3 Building-Level Water Metering - Install permanent water meters that measure potable water use, share data with USGBC | NA |
| 0 | 1 | 0 | 0 | 0 | Credit Outdoor Water Use Reduction - Reduce water use no irrigation or reduced irrigation 50% - 100% | 2 |
| 0 | 1 | 0 | 0 | 0 | Credit Indoor Water Use Reduction - Reduce fixture and fitting water use by 25% - 50% | 6 |
| 0 | 1 | 0 | 0 | 0 | Credit Cooling Tower Water Use - Conduct a one-time potable water analysis, measure control parameters in Table 1 | 2 |
| 0 | 1 | 0 | 0 | 0 | Credit Water Metering - Meters for 2 or more water subsystems: irrigation, indoor plumbing, hot water, boiler, reclaimed water, or other | 1 |
| Totals 0 5 | | | | | | |
| REQUIRED | | | | | | |
| 0 | 1 | 0 | 0 | 0 | Prereq1 Fundamental Commissioning and Verification - Commissioning for ASHRAE 9-2005 and 1.1-2007 | NA |
| 0 | 1 | 0 | 0 | 0 | Prereq2 Minimum Energy Performance - Whole building energy simulation OR ASHRAE 90.1 Design Guide OR ABCPS | NA |
| 0 | 1 | 0 | 0 | 0 | Prereq3 Building-Level Energy Metering - Use building-level energy meters or submeters that can aggregate building-level data | NA |
| 0 | 1 | 0 | 0 | 0 | Prereq4 Fundamental Refrigerant Management - Do not use CFC-based refrigerants in HVAC/R systems, or have phase-out plan | NA |
| 0 | 1 | 0 | 0 | 0 | Credit Enhanced Commissioning - Implement systems commissioning or monitor-based commissioning | 6 |
| 0 | 1 | 0 | 0 | 0 | Credit LEED v4.1: Outdoor Design Performance - Whole building energy simulation or follow ASHRAE Advanced Energy Design Guide | 18 |
| 0 | 1 | 0 | 0 | 0 | Credit Advanced Energy Metering - Install advanced energy metering for whole building and individual energy sources | 1 |
| 0 | 1 | 0 | 0 | 0 | Credit Demand Response - Participate in a demand response program or provide infrastructure for demand response programs | 2 |
| 0 | 1 | 0 | 0 | 0 | Credit LEED v4.1: Renewable Energy - Use on-site or off-site renewable energy to offset greenhouse gas emissions for annual energy use | 5 |
| 0 | 1 | 0 | 0 | 0 | Credit Enhanced Refrigerant Management - Refrigerants with ODP of 0 and GWP of less than 50 OR calculate refrigerant impact | 1 |
| Totals 0 1 33 | | | | | | |

| AWARDED | LIKELY | PURSUIT | NO | Phase | Credit Name | Points Available |
|---|--------|---------|----|-------|---|------------------|
| 0 | 1 | 1 | 0 | 0 | Prereq Storage and Collection of Recyclables - Dedicated areas for waste collection, collection and storage | NA |
| 0 | 1 | 0 | 0 | 0 | Prereq Construction and Demolition Waste Management Planning - Estimate C&D waste diversion goals | NA |
| 0 | 1 | 0 | 0 | 0 | Credit Building Life-Cycle Impact Reduction - Historic building reuse, reuse/recycle high end building OR whole building LCA | 5 |
| 0 | 1 | 0 | 0 | 0 | Credit LEED v4.1: Building Product Disclosure and Optimization - Environmental Product Declarations | 2 |
| 0 | 1 | 0 | 0 | 0 | Credit LEED v4.1: Building Product Disclosure and Optimization - Material Ingredients | 2 |
| 0 | 1 | 0 | 0 | 0 | Credit LEED v4.1: Building Product Disclosure and Optimization - Sourcing of Raw Materials | 2 |
| 0 | 1 | 0 | 0 | 0 | Credit C&D Waste Management - Divert 50% (3 streams), 75% (4 streams) OR 2.5 lbs waste per square foot | 2 |
| Totals 0 1 10 | | | | | | |
| REQUIRED | | | | | | |
| 0 | 1 | 0 | 0 | 0 | Prereq Minimum Indoor Air Quality Performance - Meet ASHRAE 62.1-2010 | NA |
| 0 | 1 | 0 | 0 | 0 | Prereq Environmental Tobacco Smoke Control - Prohibit smoking indoors, restrict outdoor smoking within 25 feet | NA |
| 0 | 1 | 0 | 0 | 0 | Credit Enhanced Indoor Air Quality Strategies - Comply with enhanced IAQ strategies | 2 |
| 0 | 1 | 0 | 0 | 0 | Credit LEED v4.1: Low-Volatility Materials - Achieve level of compliance for product categories or use budget calculation method | 3 |
| 0 | 1 | 0 | 0 | 0 | Credit Construct an IAQM Plan - Implement IAQM Plan & provide materials and equipment during construction | 1 |
| 0 | 1 | 0 | 0 | 0 | Credit Indoor Air Quality Assessment - Before and during occupancy flush-out OR conduct baseline IAQ testing | 2 |
| 0 | 1 | 0 | 0 | 0 | Credit Thermal Comfort - Meet requirements for ASHRAE 55-2010 | 1 |
| 0 | 1 | 0 | 0 | 0 | Credit Interior Lighting - Lighting Controls for 50% plus intentional occupant space & fix lighting quality strategies | 2 |
| 0 | 1 | 0 | 0 | 0 | Credit Daylight - Install gas control devices, spatial daylight access, illuminance calculations OR daylight factor area requirement | 3 |
| 0 | 1 | 0 | 0 | 0 | Credit Quality Views - Vision glazing for 75% of regularly occupied floor area, with at least two kinds of view type | 1 |
| 0 | 1 | 0 | 0 | 0 | Credit LEED v4.1: Acoustic Performance - Meet requirements for HVAC noise, sound isolation, reverberation time, & sound masking | 1 |
| Totals 0 1 15 | | | | | | |
| REQUIRED | | | | | | |
| 0 | 1 | 0 | 0 | 0 | Credit GHG Starter Kit: Green Cleaning & IPM | 1 |
| 0 | 1 | 0 | 0 | 0 | Credit Integrative Analysis of Building Materials (or BPOD EP / Green EP) | 1 |
| 0 | 1 | 0 | 0 | 0 | Credit Circular Products (or BPOD EP / Green EP) | 1 |
| 0 | 1 | 0 | 0 | 0 | Credit Green Education | 1 |
| 0 | 1 | 0 | 0 | 0 | Credit V4.1 Purchasing Large - Low Volatility Lighting | 1 |
| 0 | 1 | 0 | 0 | 0 | Credit LEED Accredited Professionals | 1 |
| Totals 0 1 6 | | | | | | |
| *Innovation at Design (includes Exemplary Performance credits) | | | | | | |
| 0 | 1 | 0 | 0 | 0 | Credit Optimize Energy Performance | 1 |
| 0 | 1 | 0 | 0 | 0 | Credit BPOD - Sourcing of Raw Materials | 1 |
| 0 | 1 | 0 | 0 | 0 | Credit Resource Management | 1 |
| 0 | 1 | 0 | 0 | 0 | Credit Indoor Water Use Reduction | 1 |
| 0 | 1 | 0 | 0 | 0 | Credit Access to Quality Transit | 1 |
| 0 | 1 | 0 | 0 | 0 | Credit Building Life Cycle Impact Reduction | 1 |
| Totals 0 1 5 | | | | | | |
| *Energy & Regional Credits are Applicable | | | | | | |
| Confirmed Certification Level: | | | | | | |
| Awarded + Likely Certification Level: | | | | | | PLATINUM |
| Awarded + Likely + Pursuing Certification Level: | | | | | | Platinum |
| Awarded Points | | | | | | |
| GOLD / PLATINUM PURSUIT (Awarded + Likely Points) | | | | | | 80 |
| PLATINUM PURSUIT (Awarded + Likely + Pursuing Points) | | | | | | 85 |



Design for Natural Daylight and Views

Menlo Park Reach Codes

“The 2019 California Building Standards Code and the California Code of Regulation will take in effect on January 1, 2020. The City of Menlo Park adopted groundbreaking local amendments to the State Building Code that would **require electricity as the only fuel source for new buildings** (not natural gas).”

Energy Intensity Unit (EUI) Defined:

“Energy use intensity (EUI) is an indicator of the energy efficiency of a building’s design and/or operations. EUI can be thought of as the miles per gallon rating of the building industry.”

<https://aiacalifornia.org/energy-use-intensity-eui/>

Site Energy Use Intensity (EUI)

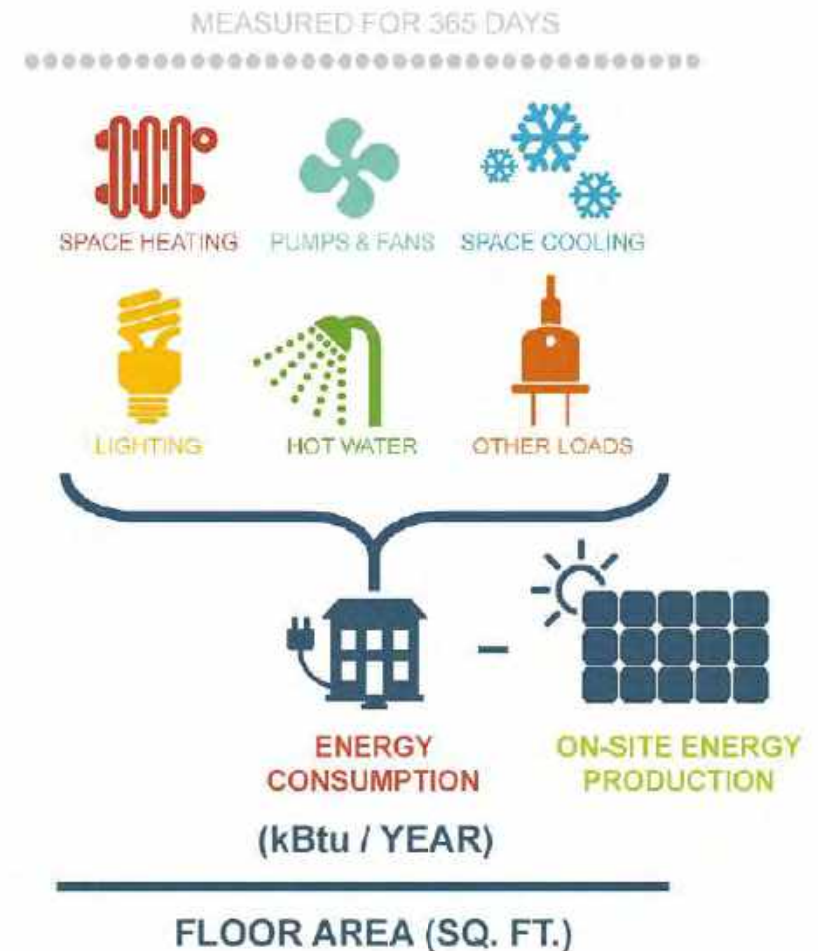

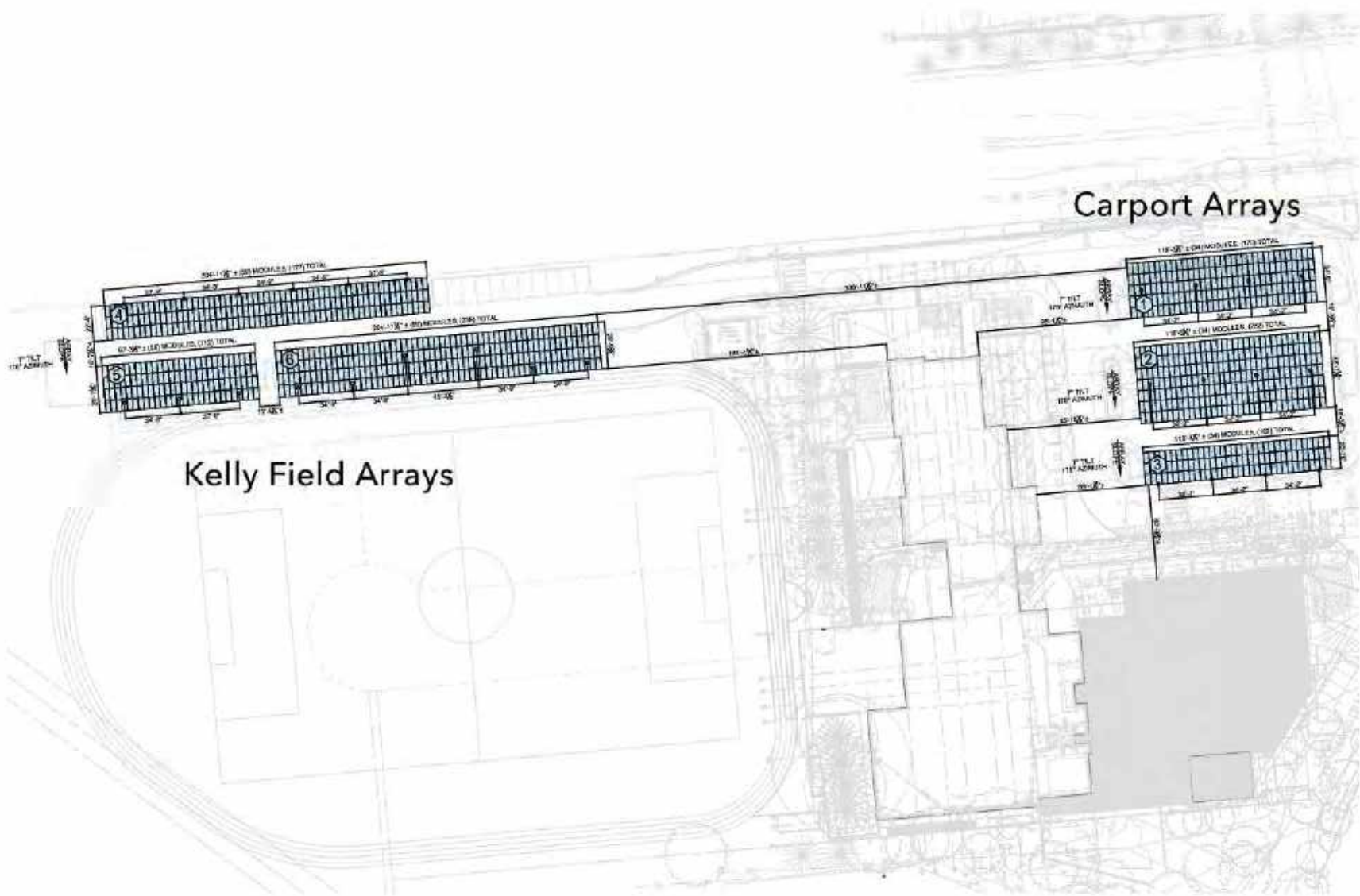

Solar Photovoltaic / Solar Thermal Arrays at Kelly Field + Carports

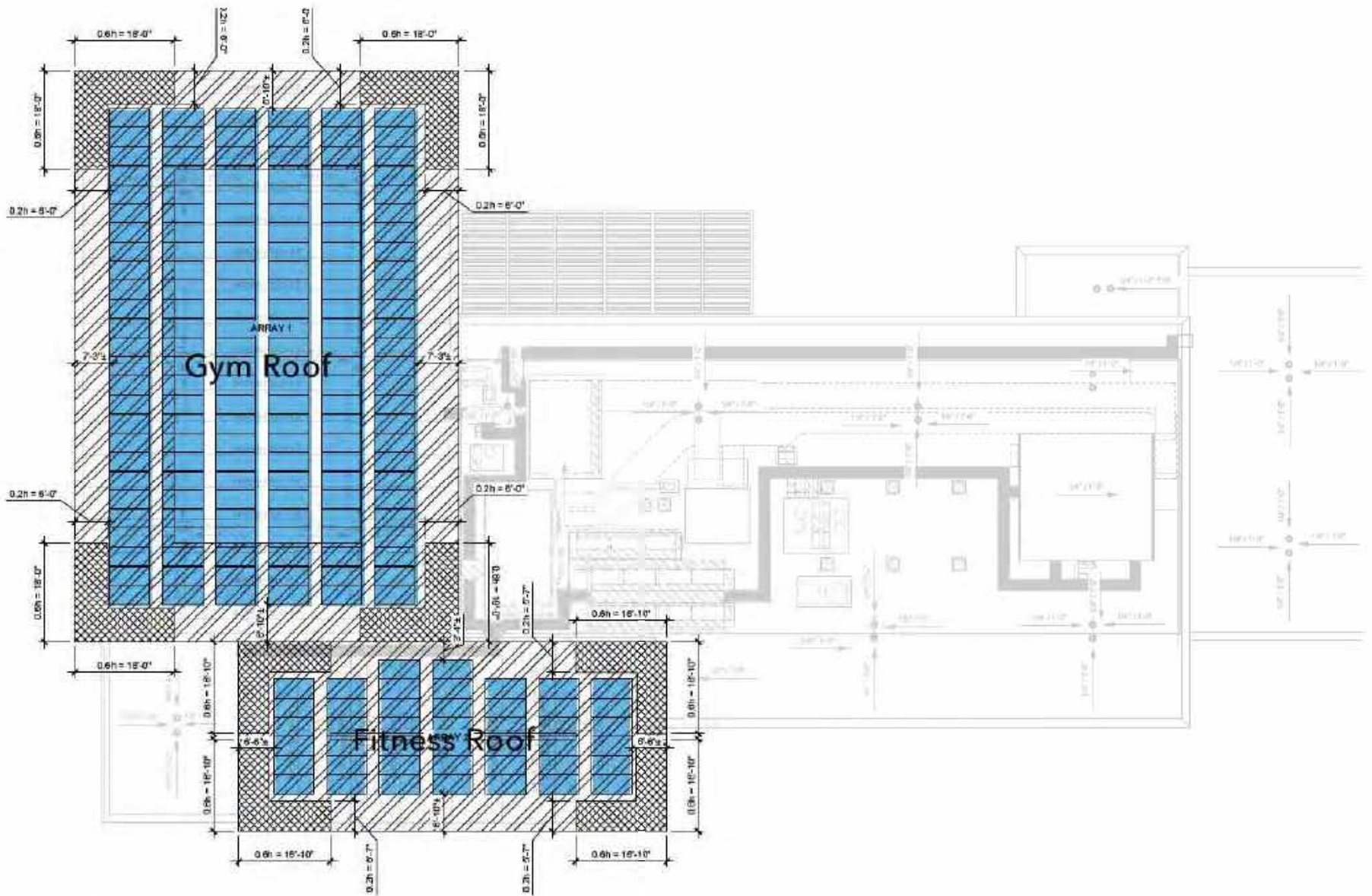

Solar Photovoltaic Arrays at Rooftops

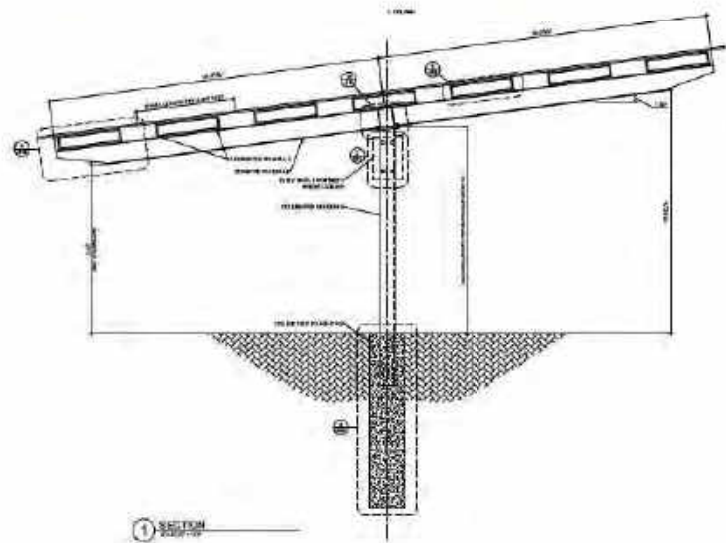

Solar Photovoltaic + Solar Thermal Arrays

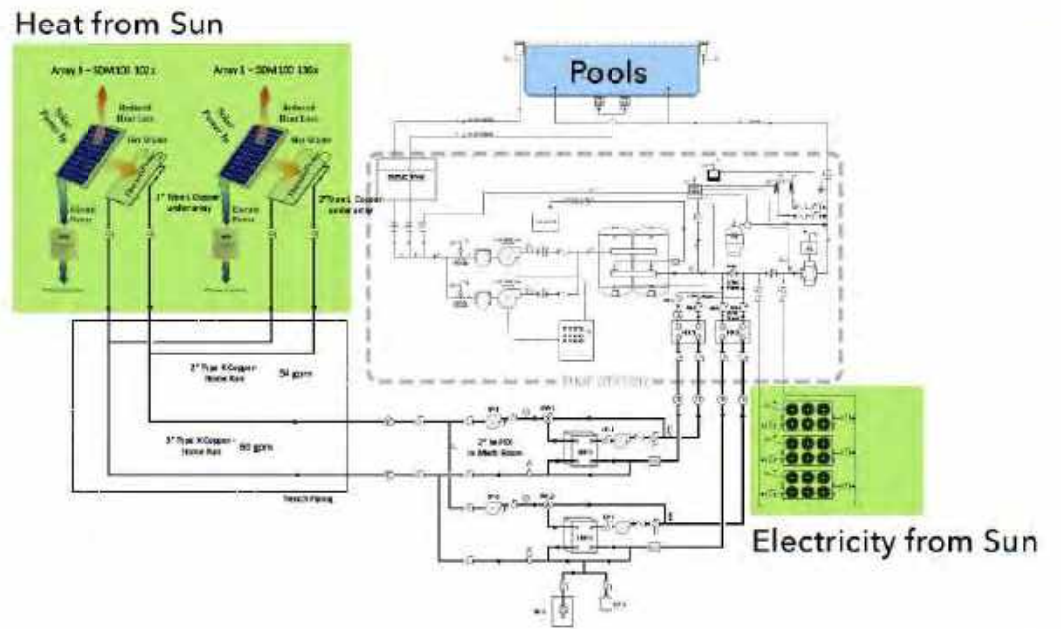

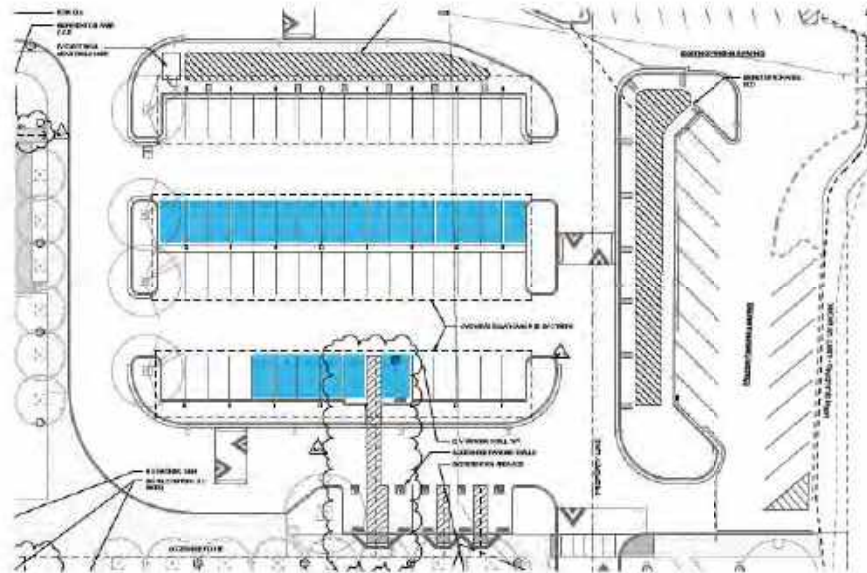

27 EV Charging Stations

THE MENLO PARK COMMUNITY CAMPUS MICROGRID

Microgrid Defined:

"a small network of electricity users with a local source of supply that is usually attached to a centralized national grid but is able to function independently."



THE MEGAPACK

Applications:

- Renewable Smoothing
- T&D Investment Deferral
- Voltage Support
- Capacity Support
- Microgrid
- Market Participation
- Frequency Regulation



<https://www.tesla.com/megapack>

HART HOWERTON

"... study by the Northeast Energy Efficiency Partnerships found that when units designed specifically for colder regions were installed in the Northeast and Mid-Atlantic regions, the annual savings are around 3,000 kWh (or \$459) when compared to electric resistance heaters, and 6,200 kWh (or \$948) when compared to oil systems."

<https://www.energy.gov/energysaver/air-source-heat-pumps>



Air Source Heat Pumps

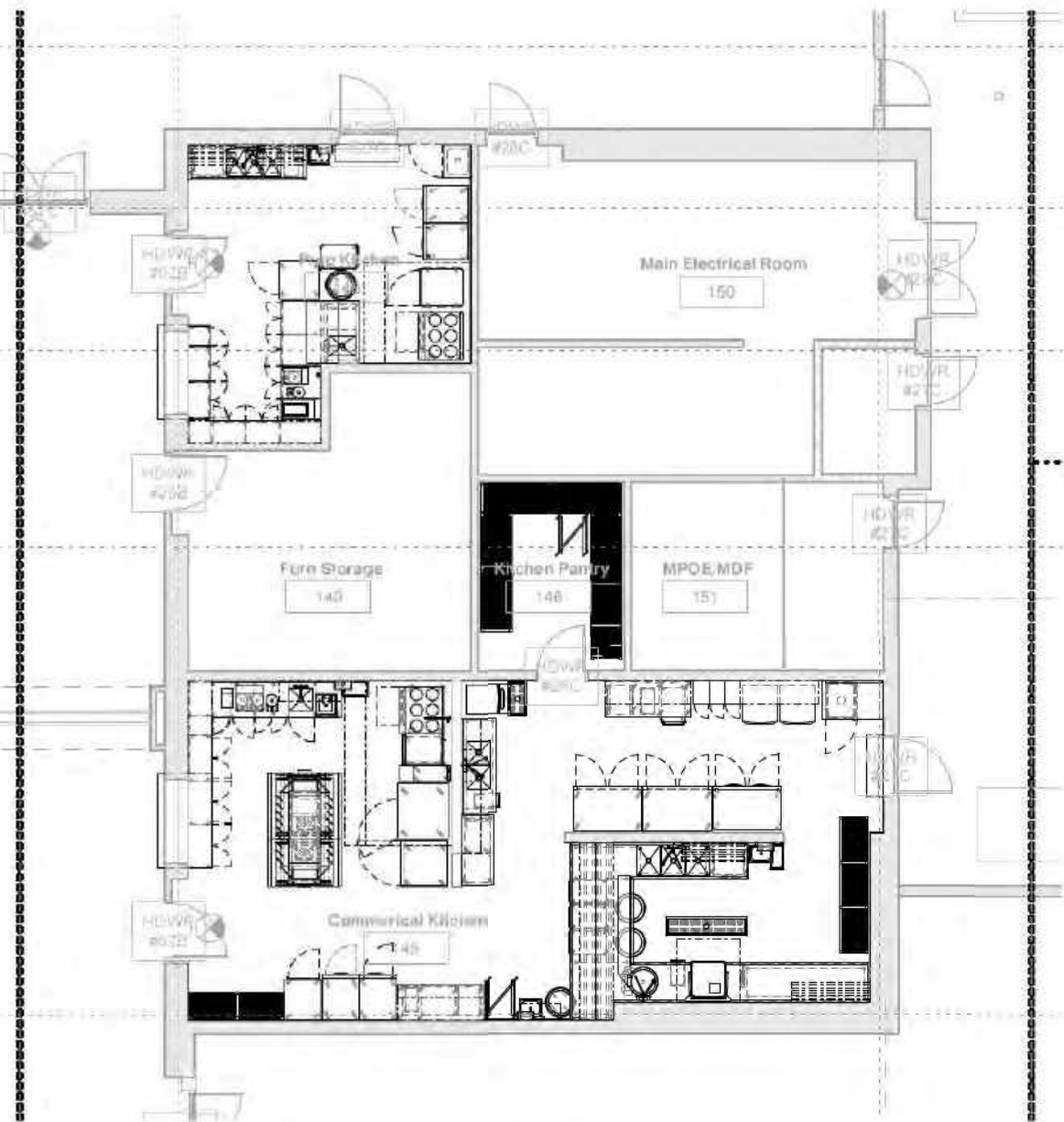

All-Electric Commercial Kitchen



Menlo Park Community Campus | Final Planning Submittal Rendering - Children's Terrace

HART HOWERTON



Questions





1 Senior Lounge 1

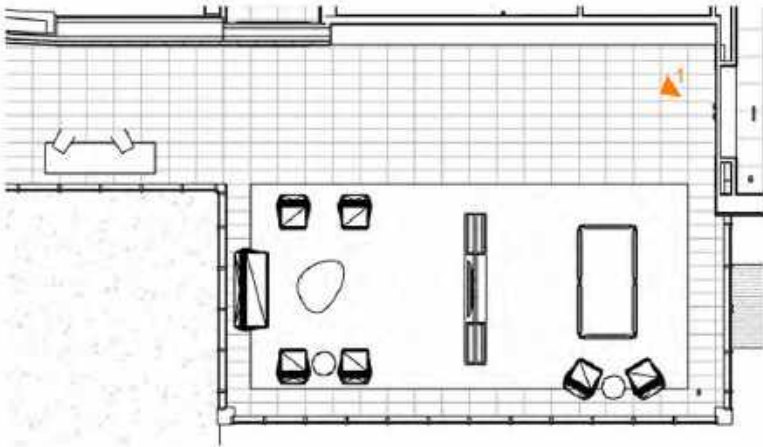



SENIOR LOUNGE
FIRST FLOOR
Page F-1.81



2 Children's Library 1



3 Children's Library 2

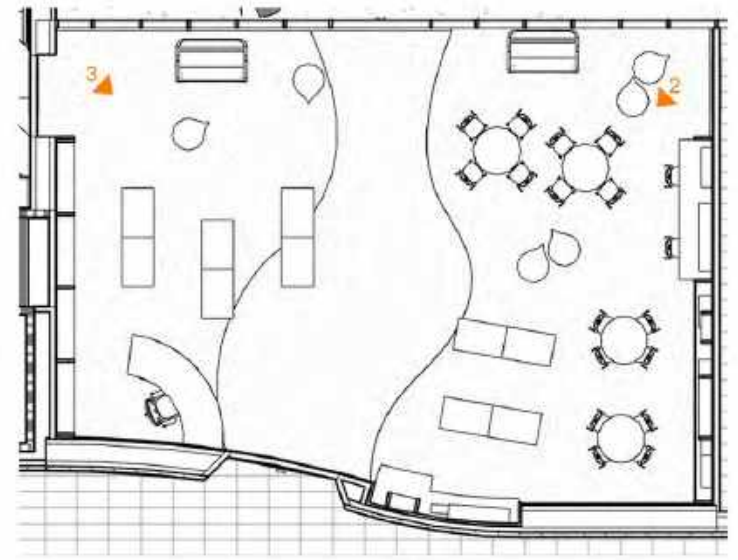





4 Makerspace 1



5 Makerspace 2





MAKERSPACE
SECOND FLOOR

Page F-1.85

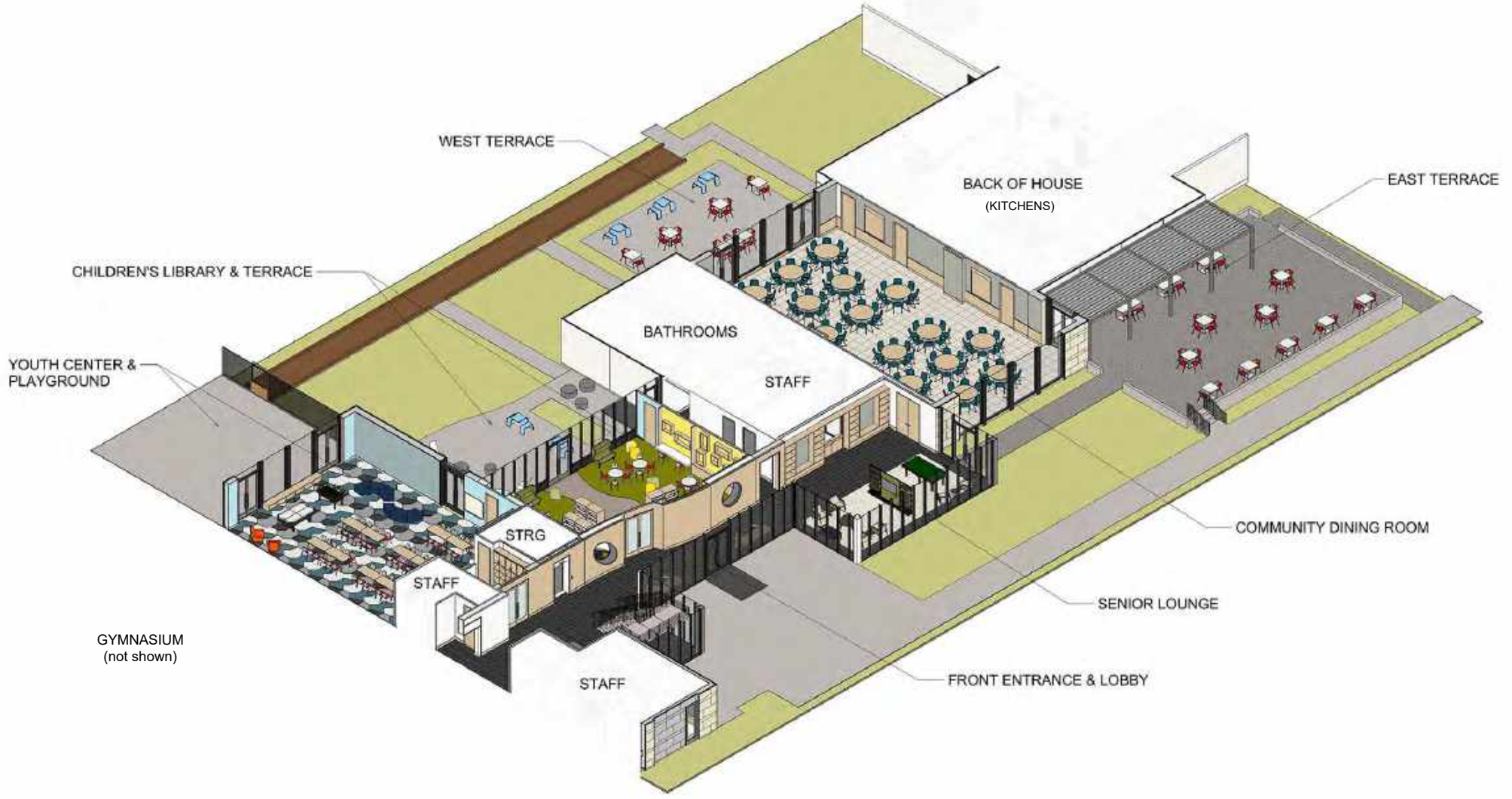

FIRST FLOOR

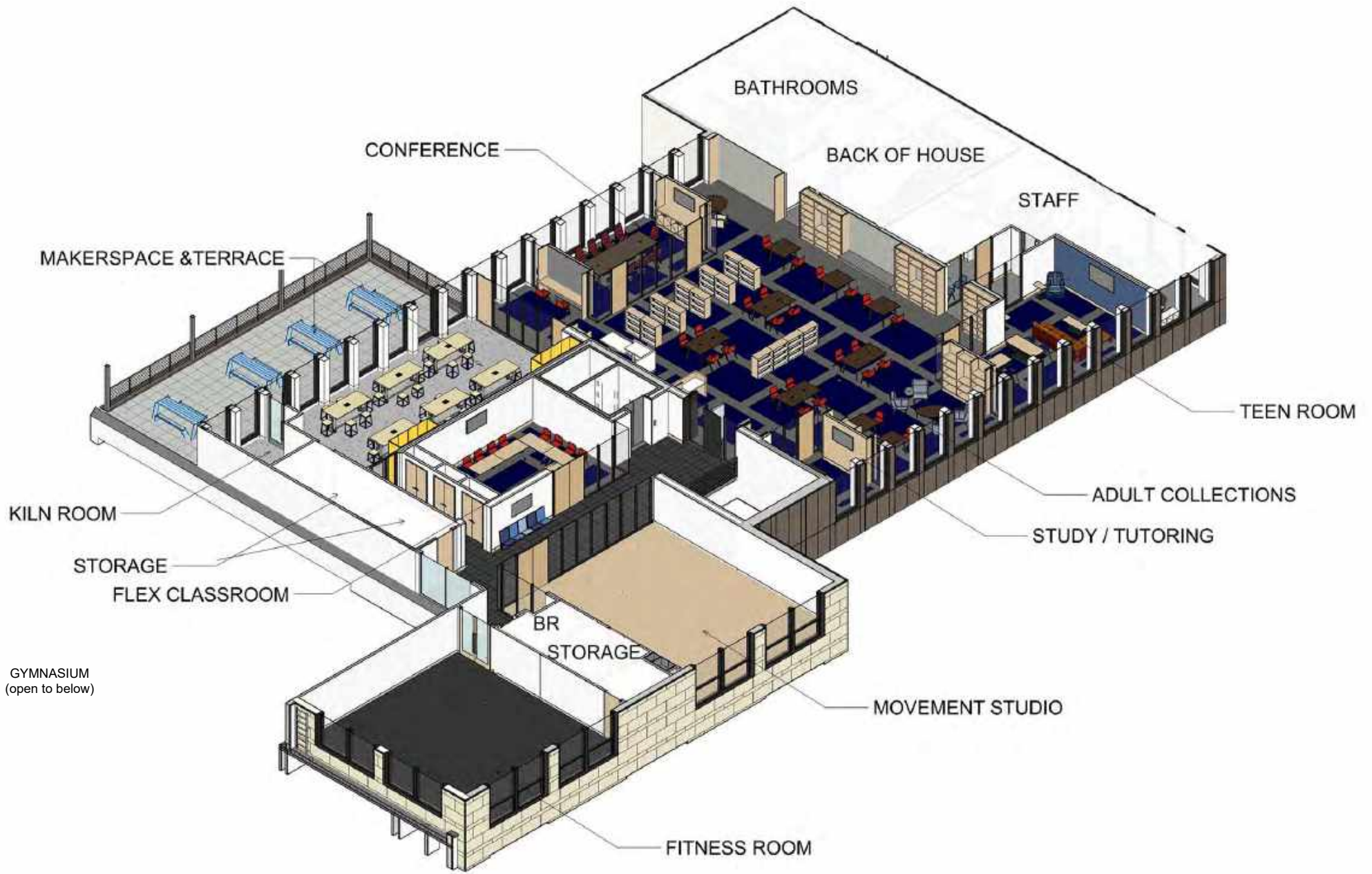

SECOND FLOOR



SPECIAL AND REGULAR MEETING MINUTES – DRAFT

Date: 7/26/2022
Time: 5:00 p.m.
Location: Zoom

Special Session

A. Call To Order

Mayor Nash called the meeting to order at 5:01 p.m.

B. Roll Call

Present: Combs, Mueller (arrived at 7:36 p.m. and exited at 10:45 p.m.), Nash, Taylor, Wolosin (exited at 10:59 p.m.)
Absent: None
Staff: Acting City Manager Dave Norris, City Attorney Nira F. Doherty, Assistant to the City Manager/City Clerk Judi A. Herren

C. Agenda Review

Staff requested to provide an update on item I1.

ACTION: Motion and second (Nash/ Taylor), to reorder the agenda in order to hear items J1. and J2. related to the ballot measure, once the full City Council is present, passed 4-0 (Mueller absent).

Closed Session

D. Closed Session

D1. CONFERENCE WITH LEGAL COUNSEL—ANTICIPATED LITIGATION
Initiation of litigation pursuant to paragraph (4) of subdivision (d) of Section 54956.9 of the Government Code: (one potential case)

Mayor Nash adjourned to the closed session at 5:05 p.m.

Regular Session

Mayor Nash reconvened the regular meeting at 6:19 p.m.

E. Report from Closed Session

No reportable actions.

F. Presentations and Proclamations

F1. Proclamation: July as Parks and Recreation Month (Attachment)

Mayor Nash read the proclamation (Attachment).

Library and Community Services Director Sean Reinhart accepted the proclamation.

F2. Recognition: RethinkWaste Trash-to-Art Contest (Attachment)

Mayor Nash introduced Laurel School Fourth Grade Teacher, Ms. Whiteley.

Laurel School Fourth Grade Teacher, Ms. Whiteley and Fourth grade students' Louis Smith and Lila Murphy made the presentation (Attachment).

G. Public Comment

- Lindsay Raike requested the City Council adopt a resolution supporting the reopening of the Mack E. Mickelson therapeutic pool.
- Elizabeth McCarthy requested clarification on the noise ordinance and ramifications for businesses who violate enforcement.
- Carolyn Ordonez spoke in opposition of the increased traffic due to the Haven House connection, which could result from the proposed apartment complex.
- Ole Agesen spoke in support of leadership in climate change.
- Wendy Shindler spoke in opposition of side-by-side developments on Bay Road.

H. Advisory Body Member Reports

H1. Receive and file Environmental Quality Commission progress report (Staff Report #22-147-CC)

Sustainability Manager Rebecca Lucky introduced the item.

Environmental Quality Commission (EQC) Chair Tom Kabat made the presentation (Attachment).

- Crystal Hernandez spoke in support of REACH goals.
- Zachary Meyer spoke in support of increasing the pace of the climate action plan (CAP) initiatives and eliminating fossil fuel.
- Saman de Silva spoke in support of increasing the pace of REACH codes.
- Robert Gould spoke in support of rapid building electrification and addressing the climate crisis.
- Nicole Kemeny spoke in support for the EQC CAP goals.
- Alex Wogonfeld spoke in support of a more rapid response to the climate crisis.

The City Council discussed benefits of converting to electric buildings, increasing public outreach and education, and impacts to residents both current and future.

I. Consent Calendar

I1. Accept the City Council meeting minutes for June 28 and July 12, 2022 (Attachment)

Assistant to the City Manager/City Clerk Judi Herren provided an update.

I2. Adopt a resolution to continue conducting the City's Council and advisory body meetings remotely due to health and safety concerns for the public and to authorize the use of hybrid meetings

(Staff Report #22-140-CC)

- I3. Authorize the city manager to enter into master professional agreements with Cotton, Shires and Associates, Inc. and Ninyo & Moore Consulting Geotechnical and Civil Engineer (Staff Report #22-139-CC)
- I4. Adopt a resolution approving an exception to the 180-day waiting period to hire a CalPERS retired annuitant in accordance with Government Code Sections 7522.56 and 21224 (Staff Report #22-141-CC)
- I5. Authorize the city manager to enter into agreements with Aqua-Metric Sales Company and Sensus USA Inc. for the automated water meter infrastructure project (Staff Report #22-143-CC)
- I6. Adopt a resolution to reduce the posted speed limit in school zones consistent with the California Vehicle Code (Staff Report #22-146-CC)

ACTION: Motion and second (Taylor/ Wolosin), to approve the consent calendar with updates to item I1., passed 4-0 (Mueller absent).

The City Council reordered agenda.

J. Public Hearing

- J3. Consider and adopt a resolution approving a revision to a previously approved vesting tentative map to change the expiration date of the map associated with the mixed-use development project located at 706-716 Santa Cruz Avenue (Staff Report #22-149-CC)

Associate Planner Fahteen Khan made the presentation (Attachment).

Applicant Phil Hyndman made a presentation.

Mayor Nash opened the public hearing.

- Paul Collacchi requested clarification on the vesting map and application.

Mayor Nash closed the public hearing.

The City Council received clarification on below market rate (BMR) requirements, the vesting map, and permitting and public review copy.

ACTION: Motion and second (Wolosin/ Nash), to adopt a resolution to approve a two-year extension of a vesting tentative map associated with a major subdivision not to exceed four residential condominium units and one commercial area, with rights reserved for up to ten commercial condominium units, passed unanimously.

The City Council took a recess at 7:50 p.m.

The City Council reconvened at 8:01 p.m.

- J1. Receive the Elections Code Section 9212 report regarding the proposed initiative measure entitled

“A Citizen-Sponsored Initiative Measure to Amend the Land Use Element of the General Plan to Prohibit the City Council of the City of Menlo Park from Re-Designating or Re-Zoning Certain Properties Designated and Zoned for Single Family Detached Homes” (Staff Report #22-148-CC)

Assistant Community Development Director Deanna Chow introduced the item.

M-Group representative Geoff Bradley and BAE Urban Economics representative Stephanie Hagar made the presentation (Attachment).

Mayor Nash opened the public hearing.

- Rini Sen Gupta spoke in support of the re-zoning ballot measure.
- Steve Wong spoke in support of the re-zoning ballot measure.
- Sarah Tappin spoke in support of teacher housing and in opposition of the re-zoning ballot measure.
- Alex Torres spoke in opposition of the re-zoning ballot measure.
- Jaggi Ayyangar spoke in support of thoughtful housing considerations and of re-zoning.
- Rob Silano spoke in support of placing the measure on the ballot and expressed concerns on the effects of traffic to safety services.
- Katheen Daly spoke in support of teacher housing and in opposition of the re-zoning ballot measure.
- Nicole Kemeny spoke in opposition of the re-zoning ballot measure.
- Karen Grove spoke in opposition of the re-zoning ballot measure and the impacts to racial and educational inequities.
- Evelyn Stivers spoke in opposition of the re-zoning ballot measure and in support of affordable housing.
- Buck Bard spoke on concerns related to the reports focus on the Flood School Site and not focusing on Menlo Park as a whole.
- Nicole Chessari spoke in opposition of high density housing in a neighborhood, in support of re-zoning, and commented on report findings.
- Kelly White spoke in support of the ballot measure and re-zoning.
- Ronen Vengosh spoke in opposition of the ballot measure.
- Keith Diggs spoke in support of accepting the report and in opposition of the re-zoning ballot measure.
- Ruth Schechter spoke in support of the ballot measure and re-zoning.
- Jennifer Schindler spoke in opposition of the ballot measure and re-zoning.
- Jennifer Michel spoke in support of the report.
- Dave Housler spoke in support of the re-zoning ballot measure.
- Wayne Muesse spoke in support of the re-zoning ballot measure.
- Sandeep Gupta spoke in support of the re-zoning ballot measure.
- Michael Levinson spoke in opposition of the re-zoning ballot measure.
- Ann Diederich spoke in opposition of the re-zoning ballot measure.
- Bernard Rehdesi spoke in support of the re-zoning ballot measure and dedicated teacher housing.
- Adina Levin spoke in opposition of the re-zoning ballot measure.
- Katie Behroozi spoke in opposition of the re-zoning ballot measure.
- Paul Collacchi spoke in support of additional housing and of the re-zoning ballot measure.

- Catherine Dumont spoke in opposition of the re-zoning ballot measure.

Mayor Nash closed the public hearing.

The City Council discussed the report.

- J2. Determination of action, pursuant to Elections Code Section 9215, regarding the proposed initiative measure entitled “A Citizen-Sponsored Initiative Measure to Amend the Land Use Element of the General Plan to Prohibit the City Council of the City of Menlo Park from Re-Designating or Re-Zoning Certain Properties Designated and Zoned for Single Family Detached Homes” (Staff Report #22-142-CC)

City Attorney Nira Doherty made the presentation.

Mayor Nash opened the public hearing.

- Gina Sudaria spoke in opposition of the re-zoning ballot measure.
- Lesley Feldman spoke in opposition of the re-zoning ballot measure.
- Pam Jones spoke in opposition of the re-zoning ballot measure.
- Karen Grove spoke in opposition of the re-zoning ballot measure and in support of the ballot measure argument deadline update.
- Adina Levin spoke in support of the ballot measure argument deadline update.
- Jennifer Michel spoke in opposition of the re-zoning ballot measure.
- James Pistorino requested clarification on Ravenswood School district funding compared to other school districts.
- Bernard Rehdesi spoke in support of the re-zoning ballot measure.

Mayor Nash closed the public hearing.

The City Council received clarification on the proposed deadline date of August 14 for receipt of ballot arguments.

The City Council discussed the relationship between the initiative and the ballot measure, the history of ConnectMenlo, and up-zoning in single family neighborhoods.

The City Council directed the deadline date of August 14 for receipt of ballot arguments.

ACTION: Motion and second (Nash/ Combs), to adopt a resolution of the City Council of the City of Menlo Park ordering the submission to the qualified electors of the City of Menlo Park a Citizen-Sponsored Initiative Measure to amend the land use element of the General Plan to prohibit the City Council of the City of Menlo Park from re-designating or re-zoning certain properties designated and zoned for single family detached homes, at the consolidated general election on Tuesday, November 8, 2022; establishing the schedule for submission of ballot arguments; and authorize and request the County of San Mateo conduct the election, with the following changes to the second to last recital on the resolution to read, “Whereas the City Council and City of Menlo Park resolves to submit the initiative to the voters of the general election to be held on November 8, 2022”, Section 6 of the resolution will be revised to read in full as follows “Submission of valid arguments, the City Council hereby adopts provisions for the filing valid arguments and rebuttal arguments for the initiative set forth in California Elections Code Section 9282. All arguments for and against the measure shall be filed with the city clerk no later than August 14, 2022 at 5 p.m. All other

timelines set forth in the County of San Mateo’s election calendar for the November 8, 2022 general election shall apply. Such timelines, including the 10 calendar day examination or review period shall begin on August 9, 2022 at 5 p.m. and August 29, 2022 at 5 p.m. Rebuttal arguments for measures where primary argument was filed, both in favor and against are due August 29, 2022 to 5 p.m. All arguments for and against the measure shall provide copies of the documentation set forth in the Elections Code Section 9287(b), shall be signed with printed names and signatures of the authors submitting it or submitted on behalf of an organization, the name of the organization and the printed name and signature have at least one of its principal office officers who is the author of the argument”, passed unanimously.

K. Regular Business

- K1. Authorize the city manager to execute an amendment to the professional services agreement with Team Sheeper, Inc. for continued operation of Burgess Pool through August 31, 2023 (Staff Report #22-144-CC)

City Councilmember Mueller was recused from the item and exited the meeting.

Library and Community Services Director Sean Reinhart made the presentation.

- Paul Collacchi spoke in opposition of a privatized public pool.
- Solo Aquatics Coach Tom McRae spoke in support of extending Tim Sheeper’s Inc. agreement and of a future request for proposal.

The City Council received clarification on the agreement.

ACTION: Motion and second (Combs/ Nash), to authorize city manager to execute an amendment to the professional services agreement between the City of Menlo Park and Team Sheeper, Inc. for continued operation of Burgess Pool, as follows:

1. Section 3 of the Agreement dated March 27, 2018, is repealed in its entirety and replaced with the following language: The term of this Agreement shall terminate August 31, 2023; and
 2. Except to the extent expressly modified by this Third Amendment, the terms of the Agreement, as amended by the first amendment and second amendment, shall remain effective without impairment or modification; and
 3. This Third Amendment may be executed in counterparts, each of which shall be deemed an original, but all of which when taken together shall constitute one amendment,
- passed 4-0 (Mueller recused).

The City Council continued K2. to a future meeting.

- K2. Waive the first reading and introduce an ordinance adding Chapter 8.70 creating a process for obtaining film permits (Staff Report #22-145-CC)

L. Informational Items

- L1. City Council agenda topics: August 2022 (Staff Report #22-150-CC)

City Manager Reports

Acting City Manager Dave Norris reported out on the August 2 National Night Out and police department Tesla vehicles scheduled to go live next month.

N. City Councilmember Reports

None.

Closed Session

O. Closed Session

O1. Closed Session Pursuant to Government Code Section 54956.95:

(1) LIABILITY CLAIM

Claimant: Richard Struckman

Agency claimed against: City of Menlo Park

(2) LIABILITY CLAIM

Claimant: Richard Struckman

Agency claimed against: City of Menlo Park

Mayor Nash adjourned to the closed session at 11:02 p.m.

Q. Adjournment

Mayor Nash adjourned the meeting at 11:21 p.m.

Judi A. Herren, Assistant to the City Manager/City Clerk



REGULAR MEETING MINUTES – DRAFT

Date: 8/23/2022
Time: 6:00 p.m.
Location: Zoom

Regular Session

A. Call To Order

Mayor Nash called the meeting to order at 6:03 p.m.

B. Roll Call

Present: Combs, Mueller, Nash, Taylor, Wolosin
Absent: None
Staff: City Manager Justin Murphy, City Attorney Nira Doherty, Assistant to the City Manager/City Clerk Judi A. Herren

C. Agenda Review

Staff will be providing updates following public comment and on item E1.

D. Public Comment

None.

Police Chief Dave Norris reported out on the Oak Grove Avenue and Alma Street shooting.

E. Presentations and Proclamations

E1. Certificate of Recognition: Menlo Park Sister Cities Young Artists and Authors Showcase winner

This item was continued to the September 20 City Council meeting.

F. Study Session

F1. Review and provide direction on the updated community amenities proposal for the Willow Village master plan project (Staff Report #22-166-CC)

City Councilmember Combs was recused and exited the meeting.

Acting Planning Manager Kyle Perata made the presentation (Attachment).

Applicant Michael Ghielmetti made a presentation (Attachment).

Willow Village Subcommittee made a presentation.

- Matt Regan spoke in support of the project and proposal.
- Michael Jo spoke in support of the project

- Ali Sapirman spoke in support of project.
- Vince Rocha spoke in support of the project.
- Ken Chan spoke in support of the project.
- Bryan Shields spoke in support of the project.
- Jordan Grimes spoke in support of the project.
- Jeffrey Moore spoke in support of the project.
- Colin Bookman spoke in support of the project.
- Jenny Michel spoke in support of the project.
- Adina Levin spoke in support of the community amenities proposal and funding for affordable housing, air and noise quality, and an electric shuttle.
- Katie Behroozi spoke on concerns related to the circulation plans generating more traffic and in support of the shuttle.

The City Council received clarification on the Subcommittees recommendations and identified values.

The City Council discussed the shuttle, potential routes, and utilizing the transportation master plan for shuttle flexibility in ridership and future users.

City Councilmember Combs rejoined the meeting.

- F2. Aquatics program analysis and preliminary considerations for an aquatics operator request for proposals (Staff Report #22-163-CC)

City Councilmember Mueller was recused and exited the meeting.

Library and Community Services Director Sean Reinhart made the presentation (Attachment).

- SOLO Aquatics Coach Tom McRae spoke in support of researching numbers and the wants and needs of a pool operator request for proposals (RFP).

The City Council received clarification on in-service training requirements, best practices, and retaining popular programs regardless of operator.

The City Council discussed transportation to Burgess and Menlo Park Community Campus (MPCC) pools, prioritizing and incentivizing use by Menlo Park residents, in-house pool operations costs and options, identical or equivalent operating schedules and programs at both aquatics centers, the distinction between operating hours and lane hours (length and quality), agreement term length, and fees and cost recovery.

The City Council directed the following to be considered in the RFP:

- Operator taking over some of the maintenance responsibilities
- More frequent check-ins with operator
- Additional oversight by City staff of operations, programs, hours
- Approval by City for operators to utilize subcontractors
- Prioritize and incentivize Menlo Park resident use of the pools
- Affordable swim lesson fees for residents

City Councilmember Mueller rejoined the meeting.

G. Consent Calendar

G1. Accept the City Council meeting minutes for August 4 and 9, 2022 (Attachment)

G2. Adopt a resolution to continue conducting the City's Council and advisory body meetings remotely due to health and safety concerns for the public and to authorize the use of hybrid meetings (Staff Report #22-158-CC)

The City Council discussed holding hybrid Planning Commission meetings.

- Adina Levin spoke in support of in-person advisory body meetings.
- Jenny Michel spoke in support of hybrid meetings.
- Jacqui Cebrian spoke in support of hybrid meetings.

G3. Waive the second reading and adopt ordinances 1) amending Title 8, Peace, Safety and Morals, of the Municipal Code to create a comprehensive permitting system for public assemblies and use of City parks and facilities and 2) adding Chapter 8.70 creating a process for obtaining film permits (Staff Report #22-157-CC)

- Elizabeth McCarthy spoke on the special event permitting allowing an exemption for the noise ordinance.

The City Council discussed Café Zoe events compared to special events.

G4. Adopt a resolution modifying the City Council's regular meeting schedule to replace October 25, 2022 with October 18, 2022 (Staff Report #22-159-CC)

ACTION: Motion and second (Taylor/ Combs), to approve the consent calendar, passed unanimously.

H. Public Hearing

H1. Adopt a resolution amending the City's comprehensive master fee schedule for the city manager's office, community development, library and community services, public works departments, Menlo Park Municipal Water, and amend the User Fee Cost Recovery Policy (Staff Report #22-167-CC)

Interim Finance Director Marvin Davis made the presentation (Attachment).

Mayor Nash opened the public hearing.

Mayor Nash closed the public hearing.

The City Council received clarification on the duration of master fee schedule, fee waiver annual totals, and the next review of the master fee schedule.

The City Council discussed staff reporting back on revenue forfeitures related to electrification.

The City Council took a brief recess at 8:39 p.m.

The City Council reconvened at 8:51 p.m.

ACTION: Motion and second (Wolosin/ Mueller), to adopt a resolution amending the City's master fee schedule to incorporate proposed changes in fees to become effective immediately, August 23, 2022, or as required by statute for the following departments: city manager's office, community development, library and community services, public works, Menlo Park Municipal Water, direct staff include when electrification revenue forfeiture reaches \$150,000 the master fee schedule is returned to the City Council, and amend the User Fee Cost Recovery Policy, passed unanimously.

H2. Adopt a resolution to abandon the public service easements within the properties at 141 Jefferson Drive, 180 Constitution Drive and 186 Constitution Drive (Menlo Uptown)
(Staff Report #22-165-CC)

Associate Engineer Eric Hinkley made the presentation (Attachment).

Mayor Nash opened the public hearing.

Mayor Nash closed the public hearing.

ACTION: Motion and second (Combs/ Nash), to adopt a resolution ordering the vacation and abandonment of public service easements within the properties at 141 Jefferson Drive, 180 Constitution Drive and 186 Constitution Drive associated with the proposed redevelopment of the project site, passed unanimously.

I. Regular Business

I1. Direction regarding filling of City Council vacancies (Staff Report #22-160-CC)

City Attorney Nira Doherty made the presentation (Attachment).

- Adina Levin spoke on concerns of an unrepresented District by a City Council vacancy and in support of interim appointments.

The City Council received clarification on invalidity of the current ordinance, interim appointment timing for State law, and City Council resignations.

The City Council discussed options for amending the Menlo Park Municipal Code (MPMC), impacts of a four-member City Council pending a special election, public outreach in the District where the vacancy occurs, appointment process, and requiring an appointment upon resignation.

The City Council directed staff to draft an ordinance reflecting the State procedures for filling a councilmember vacancy which procedures provide the city council the option to fill a vacancy by appointment or election.

J. Informational Items

J1. City Council agenda topics: September 2022 (Staff Report #22-164-CC)

J2. Update on the Middle Avenue complete streets project (Staff Report #22-161-CC)

- Matthew Rascoff spoke in support of the traffic calming measures, increasing bike lanes, and

protections.

- Brendan Visser spoke in support of bike lanes in both directions.

J3. Updates about city-hosted community events and observances (Staff Report #22-162-CC)

The City Council discussed historical Halloween parades and future reports including the costs associated with events.

K. City Manager's Report

City Manager Justin Murphy reported out on walking tours of the MPCC building, music event at Belle Haven school, and the Nealon Park zip line.

L. City Councilmember Reports

Mayor Nash reported out on the MPCC building tour.

M. Adjournment

Mayor Nash adjourned the meeting at 10:21 p.m.

Assistant to the City Manager/City Clerk Judi A. Herren



STAFF REPORT

City Council

Meeting Date:

9/13/2022

Staff Report Number:

22-171-CC

Consent Calendar:

Adopt a resolution to continue conducting the City's Council and advisory body meetings remotely due to health and safety concerns for the public and to authorize the use of hybrid meetings

Recommendation

Staff recommends that the City Council adopt a resolution (Attachment A) to continue conducting the City's Council and advisory body meetings remotely due to health and safety concerns for the public and to authorize the use of hybrid meetings.

Policy Issues

Assembly Bill 361 (AB 361) was signed into law September 16, 2021 allowing cities to continue holding virtual meetings during any emergency proclaimed by the governor. AB 361 sunsets January 1, 2024. The City Council would need to declare every 30 days that the City's legislative bodies must continue to meet remotely in order to ensure the health and safety of the public.

Background

The California Legislature approved AB 361, which was signed by the governor September 16, 2021 for signature. The bill allows local legislative bodies to continue to meet remotely through January 1, 2024. A local agency will be allowed to continue to meet remotely when:

- The local agency holds a meeting during a declared state of emergency
- State or local health officials have imposed or recommended measures to promote social distancing
- Legislative bodies declare the need to meet remotely due to present imminent risks to the health or safety of attendees

The City meets the requirements to continue holding meetings remotely in order to ensure the health and safety of the public:

- The City is still under a local state of emergency
- County Health urges that all individuals in public spaces maintain social distancing and wear masks

Analysis

The City is still under a local state of emergency and the emergency findings required under AB 361 are still in effect. San Mateo County is still in the High/Red COVID-19 Community Level category and the Centers for Disease Control and Prevention (CDC) recommends the use of masks indoors in public. The resolution authorizes the use of hybrid meetings, whereby City Councilmembers, participants, and staff may choose to attend either remotely or in person.

Although the City has returned to in-person meetings, due to the prevalence of BA strains of the SARS-CoV-2 virus overtaking other variants in San Mateo County, the City Council finds that reducing the number of persons present in City Council chambers is necessary to reduce imminent health risks associated with large groups and/or members of varying households gathering indoors.

Impact on City Resources

There is no impact on City resources.

Environmental Review

This action is not a project within the meaning of the California Environmental Quality Act (CEQA) Guidelines §§ 15378 and 15061(b)(3) as it is an organizational structure change that will not result in any direct or indirect physical change in the environment.

Public Notice

Public notification was achieved by posting the agenda, with the agenda items being listed, at least 72 hours prior to the meeting.

Attachments

A. Resolution

Report prepared by:

Judi A. Herren, Assistant to the City Manager/City Clerk

RESOLUTION NO. XXXX**RESOLUTION OF THE CITY COUNCIL OF THE CITY OF MENLO PARK AND ON BEHALF OF COMMISSIONS AND COMMITTEES CREATED BY THE CITY COUNCIL PURSUANT TO CALIFORNIA GOVERNMENT CODE SECTION 54952(b) AUTHORIZING TELECONFERENCE MEETINGS IN COMPLIANCE WITH AB 361 (GOVERNMENT CODE SECTION 54953(e)) TO CONTINUE TO ALLOW MEMBERS OF THE PUBLIC TO SAFELY PARTICIPATE IN LOCAL GOVERNMENT MEETINGS**

WHEREAS, the City Council is committed to ensuring public access to observe and participate in local government meetings; and

WHEREAS, all meetings of the City Council and other legislative bodies created pursuant to Government Code Section 54952(b) are open and public, as required by the Ralph M. Brown Act, so that any member of the public may participate in local government meetings; and

WHEREAS, the AB 361, codified at Government Code section 54953(e), makes provisions for remote teleconferencing participation in local government meetings, without compliance with the requirements of 54953(b)(3), during a Governor-proclaimed state of emergency and if the local legislative body determines, by majority vote, that as a result of the emergency, meeting solely in person would present imminent risks to the health or safety of attendees; and

WHEREAS, on March 4, 2020, Governor Newsom proclaimed a State of Emergency due to the outbreak of respiratory illness due to a novel coronavirus (now known as COVID-19) and that State of Emergency is still in effect in the State of California; and

WHEREAS, on March 11, 2020 the City Council proclaimed the existence of a local state of emergency within the City, pursuant to Section 8625 of the California Emergency Services Act in response to the COVID-19 pandemic; and

WHEREAS, COVID-19 continues to threaten the health and lives of City residents; and

WHEREAS, the SARS-CoV-2 Delta and Omicron Variants are highly transmissible in indoor settings; and

WHEREAS, the Omicron subvariants of the SARS-CoV-2 virus is overtaking other variants in San Mateo County; and

WHEREAS, according to data from the County's Health Administrator and County website, the County is averaging approximately 15 new cases per 100,000 of COVID-19 per day; and

WHEREAS, although the City has returned to in-person meetings, due to the prevalence of BA strains of the SARS-CoV-2 virus overtaking other variants in San Mateo County, the City Council finds that reducing the number of persons present in City Council chambers is necessary to reduce imminent health risks associated with large groups and/or members of varying households gathering indoors; and

WHEREAS, the State of California and the City of Menlo Park continue to follow safety measures in response to COVID-19 as ordered or recommended by the Centers for Disease Control and Prevention (CDC), California Department of Public Health (DPH), and/or County of

San Mateo, as applicable, including facial coverings when required; and based upon that guidance, in-person attendance indoors at public meetings continues to present a health risk for certain segments of the population, necessitating the need to reduce the number of in-person meeting attendees; and

WHEREAS, the City Council, acting as a legislative body pursuant to Government Code section 54952(a) and for the benefit of the commissions, committees and other bodies that were created by the City Council pursuant to Government Code section 54952(b) (collectively referred to as "Legislative Bodies"), finds that the current conditions meet the circumstances set forth in Government Code section 54953(e)(3) to allow Legislative Bodies to continue to use teleconferencing to hold open and public meetings if the Legislative Bodies comply with the requirements set forth in Government Code section 54953(e)(2) to ensure the public can safely participate in and observe local government meetings.

NOW, THEREFORE, BE IT RESOLVED by the City Council of the City of Menlo Park that the City Council does hereby:

1. Find that current conditions authorize teleconference public meetings of Legislative Bodies. Based on the California Governor's continued declaration of a State of Emergency and current conditions, the City Council finds that meeting in person, without the option for certain populations and persons to participate remotely, would present imminent risks to the health or safety of attendees. The City Council does therefore find that Legislative Bodies and members of Legislative Bodies of the City may elect to use teleconferencing to hold public meetings in accordance with Government Code section 54953(e)(2) to ensure members of the public have continued access to safely observe and participate in local government meetings.
2. Authorize Legislative Bodies to conduct teleconference meetings. The Legislative Bodies are hereby authorized to take all actions necessary to carry out the intent and purpose of this Resolution, including conducting open and public meetings in accordance with Government Code section 54953(e)(2) and other applicable provisions of the Brown Act.
3. Authorize Legislative Bodies to conduct hybrid meetings. The Legislative Bodies are hereby further authorized to conduct meetings in a "hybrid" format, where both members of the Body may elect to be present in person, utilizing appropriate distancing and masking practices, or participate by teleconferencing technology. Such meetings of the Legislative Bodies that occur using teleconferencing technology will provide an opportunity for any and all members of the public who wish to address Legislative Bodies and will otherwise occur in a manner that protects the statutory and constitutional rights of parties and the members of the public attending the meeting via teleconferencing.

//

//

//

//

//

//

I, Judi A. Herren, City Clerk of Menlo Park, do hereby certify that the above and foregoing City Council Resolution was duly and regularly passed and adopted at a meeting by said City Council on the thirteenth day of September, 2022, by the following votes:

AYES:

NOES:

ABSENT:

ABSTAIN:

IN WITNESS WHEREOF, I have hereunto set my hand and affixed the Official Seal of said City on this ___ day of September, 2022.

Judi A. Herren, City Clerk



STAFF REPORT

City Council

Meeting Date:

9/13/2022

Staff Report Number:

22-168-CC

Consent Calendar:

Authorize the city manager to sign the public improvement agreement for the Menlo Portal project located at 115 Independence Drive and 104 and 110 Constitution Drive

Recommendation

Staff recommends that the City Council authorize the city manager to sign the public improvement agreement for the Menlo Portal project located at 115 Independence Drive and 104 and 110 Constitution Drive (Attachment A.)

Policy Issues

Neither the Menlo Park Municipal Code nor the conditions of approval clearly identify the staff authorized to sign public improvement agreements. Therefore, staff is requesting the City Council authorize the city manager to sign the agreement in conformance with the conditions of approval for the Menlo Portal project.

Background

The Menlo Portal project is located at 115 Independence Drive and 104 and 110 Constitution Drive. It contains 335 multifamily dwelling units and approximately 34,499 square feet of commercial space. On September 21, 2021, the City Council certified the Menlo Portal final environmental impact report, and approved the use permit, architectural control, below market rate housing agreement, community amenities operating covenant, and public utility easement abandonment. The staff report from September 14, 2021 is included as Attachment B.

Analysis

The applicant and City have agreed to the terms of the proposed public improvement agreement. Per the agreement, the applicant will provide a bond for the completion of the required off-site public improvement work. The public improvement agreement is a contract between the applicant and the City that guarantees the construction of all public street improvements. It requires a completion bond as a financial guarantee that all work will be completed. The project plans have been approved by the engineering division of the public works department.

The public improvement agreement applies to both portions of the Menlo Portal project, the Multifamily Residential component and the Office component, and governs the preparation of plans and specifications and construction of all off-site public improvements (e.g., sewer, water, electrical underground, sidewalks, landscaping, etc.) and transportation improvements imposed as conditions of the approval of the project. The Multifamily Residential component of the Menlo Portal project is proceeding first and therefore, in addition to the off-site improvements associated with the Multifamily Residential component of the project,

all of the transportation improvements required of the project will be undertaken in connection with the Multifamily Residential component.

Within 90-days following the issuance of the superstructure permit for the Multifamily Residential component of the project, the Developer is required to begin the construction of the off-site improvements associated with the Multifamily Residential component of the project; likewise, construction of all of the transportation improvements will start within 120 days following the issuance of the superstructure permit. The improvements are required to be completed upon the earlier of 24 months after construction begins or before the issuance of a certificate of occupancy for the Multifamily Residential component of the project. The Developer is required to post a performance bond to secure the faithful completion of the required work and a payment bond to secure the payment of wages due to workers on the public work of improvement. Once the public work of improvements associated with the Multifamily Residential component of the project are completed, the performance bond will convert to a warranty bond to secure the one (1) year warranty period against defects in material or workmanship.

With respect to the Office component of the project, the Developer is required to begin construction of the off-site improvements associated with the Office component of the project within 90 days following the earlier of issuance of a final certificate of occupancy for the Multifamily Residential component of the project or issuance of a superstructure permit for the Office component of the project. If the Developer is not ready to proceed with the Office component of the project by the time the Multifamily Residential component is complete and seeks occupancy, the Developer can request an extension of the time to begin the off-site improvements for the Office component of the project. However, any extension will require the posting of performance and payment bonds to secure the faithful performance of the work and payment of wages due to workers. Once the work begins, it is required to be completed upon the earlier of 24 months or before the issuance of a certificate of occupancy for the Office component of the project. Again, once the public work of improvements associated with the Office component of the project are completed, the performance bond will convert to a warranty bond to secure the one (1) year warranty period against defects in material or workmanship.

Transportation improvements

The off-site improvements include improvements at one intersection to address level of service (LOS) deficiencies as defined by the City's transportation impact analysis guidelines and General Plan policies. The improvement is located at Chrysler Drive and Independence Drive and requires the installation of an all-way stop sign at the intersection.

Impact on City Resources

The staff time costs associated with the review and approval of the public improvement agreement are fully recoverable through fees collected from the applicant.

Environmental Review

A final environmental impact report was prepared for the project and certified by the City Council September 14, 2021. No additional environmental review is required for the approval of the public improvement agreement.

Public Notice

Public notification was achieved by posting the agenda, with the agenda items being listed, at least 72

hours prior to the meeting.

Attachments

- A. Public improvement agreement
- B. Hyperlink – September 14, 2021, City Council staff report:
menlopark.org/files/sharedassets/public/agendas-and-minutes/city-council/2021-meetings/agendas/20210914-city-council-agenda-packet.pdf

Report prepared by:
Nikki Nagaya, Public Works Director

Recording requested by and when
Recorded return to:

City of Menlo Park
Attn: City Clerk
701 Laurel Street
Menlo Park, CA 94025-3483

Exempt From Recording Fees Per
Government Code §27383 And
Building Homes & Jobs Trust Fund
Fee Per Government Code §27388.1(a) (2) (D)

(SPACE ABOVE THIS LINE FOR RECORDER’S USE)
APN: 055-236-320 and 055-236-310

PUBLIC IMPROVEMENT AGREEMENT

Portal - Multifamily Residential and Office Improvements

This PUBLIC IMPROVEMENT AGREEMENT (this “**Agreement**”), is entered into as of _____, 2022 (the “**Effective Date**”), by and between the CITY OF MENLO PARK, a municipal corporation of the State of California (“**City**”), GS MP Portal Owner, LLC, a Delaware limited liability company (“**MF Owner**”) and GS MP Portal Office Owner, LLC, a Delaware limited liability company (“**Office Owner**”). MF Owner and Office Owner are collectively referred to as “**Developers**”). City, MF Owner, and Office Owner are referred to herein individually as a “**Party**” and collectively as the “**Parties.**”

RECITALS

A. WHEREAS, MF Owner owns certain real property located at 110 Constitution Drive in the City of Menlo Park, County of San Mateo, State of California, designated as APN 055-236-320, and more particularly described in the legal description attached hereto as **Exhibit A-1** (the “**Multifamily Property**”) and Office Owner owns certain real property located at 104 Constitution Drive in the City of Menlo Park, County of San Mateo, State of California, designated as APN 055-236-310, and more particularly described in the legal description attached hereto as **Exhibit A-2** (the “**Office Property**”) The Multifamily Property and Office Property are collectively referred to as the “**Property**”.

B. WHEREAS, on August 9, 2021, after a duly noticed public hearing, and on the recommendation of the City’s Housing Commission, the City’s Planning Commission approved Planning Commission Resolution No. 2021-07, permitting Developers to develop approximately 335 multi-family residential units (“**Residential Component**”), approximately 34,499 square feet of office (“**Office Component**”), and approximately 1,609 square feet of ground-floor commercial space (the “**Project**”), subject to certain requirements and conditions contained in the Conditions

of Approval (“**Conditions of Approval**”) and on September 14, 2021, after a duly noticed public hearing, the City Council adopted Resolution Nos. 6665, 6666, and 6667 denying all appeals to, and upholding the Planning Commission’s approval of, the Project.

C. WHEREAS, pursuant to Condition of Approval 1.ww, Developers shall enter into an agreement for completion of development improvements and provide a performance bond for the completion of the off-site improvements for the Project as referenced in Condition of Approval 1.jj (green infrastructure), 1.kk (existing utilities to be relocated), 1.ll (new utilities), 1.pp (water mains and service laterals), 1.qq (sanitary sewer mains and service laterals), 2.x. (water mains and service laterals), 2.y (sanitary sewer mains and service laterals), 2.aa (remove/replace any damaged/worn frontage improvements), 2.mm (asphalt overlay), and 2.nn (loading zones-Complete Streets Commission) and more particularly listed and depicted in **Exhibit B** (the “**Off-Site Improvements**”), which Off-Site Improvements shall be installed, constructed and completed as detailed in plans and specifications approved by the Public Works Director (“**Director**”) or the City Engineer or their designees where authorized by law. Developers shall obtain an encroachment permit from the City prior to commencing any work on the Off-Site Improvements within the public right-of-way or public easements.

D. WHEREAS, Condition of Approval 2.ss. provides that Developers shall enter into an improvement agreement with the City memorializing the terms for performance, construction, and completion of the transportation improvements, which are more particularly described in **Exhibit C** (the “**Transportation Improvements**”).

D. The City and the Developers desire to enter into this Agreement in order to permit the issuance of a building permit for the development of the Project, implement and satisfy the Conditions of Approval, and simultaneously satisfy the security provisions of the City of Menlo Park Municipal Code (the “**Code**”) and the Conditions of Approval.

NOW, THEREFORE, in order to ensure satisfactory performance of the Developers under the Code and Conditions of Approval, Developers and the City agree as follows:

1. Recitals. The above recitals are true and correct, and are incorporated into this Agreement.

2. Developers’ Obligations.

(a) Off-Site Improvements and Transportation Improvements: Plans and Specifications and Construction. As more particularly described below, Developers shall, at their sole cost and expense, furnish all necessary materials, equipment, and labor as is required to prepare the designs, plans, and specifications for the Off-Site Improvements and Transportation Improvements for the Project for the review and approval of the Director of Public Works (“**Director**”) and/or the City Engineer, as applicable (the “**Plans and Specifications**”). Developers shall, at their sole cost and expense, furnish all necessary materials, equipment, and labor; perform all work in a good and workmanlike manner; and cause the Off-Site Improvements and Chrysler/Independence Improvement, as defined and if required as described below, to be designed, installed, constructed and completed in substantial conformity with the Plans and Specifications or with any changes required or ordered by the Director or City Engineer to the

approved Plans and Specifications (the “**Work**”), which in his or her reasonable opinion are necessary or required to complete the Work in compliance with all applicable federal, state and local laws, ordinances, rules, regulations and policies.

(b) Residential Improvement Plans. As of the Effective Date, the Plans and Specifications for the Off-Site Improvements for the Residential Component listed in **Exhibit B** consist of conceptual improvement plans entitled “Menlo Portal (Multifamily) Off-Site Street Improvements” prepared by BKF Engineers dated July 12, 2022, PGA Design dated June 6, 2022, and Giacalone Design, Inc. dated July 11, 2022 (“**Residential Improvement Plans**”). MF Owner shall continue to work towards completion of and City approval of one hundred percent (100%) of the Residential Improvement Plans. The City shall diligently review and process the Residential Improvement Plans submitted by MF Owner. As each stage of improvement plans are approved by the City, the more complete and recently approved improvement plans shall be the “**Residential Improvement Plans.**” MF Owner shall obtain the approval of the Residential Improvement Plans to be constructed by MF Owner in accordance with the Conditions of Approval within three (3) months from the Effective Date. Further, in no event shall the City be obligated to issue a superstructure building permit to MF Owner for the construction of the Residential Component of the Project until the Residential Improvement Plans have been approved by City.

(c) Commencement and Completion of Construction of Residential Improvement Plans. Within ninety (90) days following the issuance of a superstructure building permit for the construction of the Residential Component of the Project, MF Owner shall commence the installation and construction of the improvements set forth in the Residential Improvement Plans to be constructed by MF Owner in accordance with the Conditions of Approval and this Agreement. In the event MF Owner fails to timely commence the construction of the improvements set forth in the Residential Improvement Plans as required herein, City may, in its discretion, issue and enforce a stop work notice on all or any portion of work being undertaken by MF Owner pursuant to any building permits issued by City for the construction of any portion of the Residential Component of the Project until construction of the improvements set forth in the Residential Improvement Plans has commenced to the reasonable satisfaction of the Director or City Engineer.

MF Owner shall complete the installation and construction of the improvements set forth in the Residential Improvement Plans in accordance with Section 6 (a) [Director's Inspection] below and City shall complete the Acceptance of the improvements set forth in the Residential Improvement Plans in accordance with Section 6 (b) [Acceptance] upon the earlier of (i) twenty four (24) months following the commencement of the installation and construction of the improvements set forth in the Residential Improvement Plans or (ii) issuance of a certificate of occupancy, inclusive of a temporary certificate of occupancy, from City for any portion of the Residential Component of the Project. The period of time provided for MF Owner to complete the installation and construction of the improvements set forth in the Residential Improvement Plans pursuant to this Agreement may be extended upon application by MF Owner and approval by the Director pursuant to Section 4(b) [Extensions] below.

(d) Office Improvement Plans. As of the Effective Date, the Office Owner has not commenced the preparation of the Plans and Specifications for the Off-Site Improvements for the Office Component listed in Exhibit B (“**Office Improvement Plans**”). Office Owner shall work

towards completion of and shall obtain City approval of one hundred percent (100%) Office Improvement Plans. The City shall diligently review and process the Office Improvement Plans. As each stage of improvement plans are approved by the City, the more complete and recently approved improvement plans shall be the “**Office Improvement Plans**”.

(e) Commencement and Completion of Construction of Office Improvement Plans. Office Owner shall commence the installation and construction of the improvements set forth in the Office Improvement Plans to be constructed by Office Owner in accordance with the Conditions of Approval and this Agreement, within ninety (90) days following the earlier of (i) issuance of a final certificate of occupancy from City for the Residential Component of the Project, or (ii) issuance of a superstructure building permit from the City to Office Owner for the construction of the Office Component of the Project. In the event Office Owner fails to timely commence the construction of the improvements set forth in the Office Improvement Plans as required herein, City may, in its discretion, issue and enforce a stop work notice on all or any portion of work being undertaken by Developers pursuant to any building permits issued by City for the construction of any portion of the Project or withhold issuance of a certificate of occupancy, inclusive of a temporary certificate of occupancy for any portion of the Residential Component of the Project, until construction of the improvements set forth in the Office Improvement Plans has commenced to the reasonable satisfaction of the Director or City Engineer. The period of time provided for Office Owner to commence the installation and construction of the improvements set forth in the Office Improvement Plans pursuant to Section 2 (e)(i) above may only be extended upon application by Office Owner and approval by the Director pursuant to Section 4(b) [Extensions] below, which approval, if granted, shall be extended to a date or time certain and conditioned on the delivery of improvement security by Office Owner to City in accordance with Section 3 (c).

Office Owner shall complete the installation and construction of the improvements set forth in the Office Improvement Plans in accordance with Section 6 (a) [Director's Inspection] below and City shall complete the Acceptance of the improvements set forth in the Office Improvement Plans in accordance with Section 6 (b) [Acceptance] upon the earlier of (i) twenty four (24) months following the commencement of the installation and construction of the improvements set forth in the Office Improvement Plans or (ii) issuance of a certificate of occupancy, inclusive of a temporary certificate of occupancy, from City for any portion of the Office Component of the Project. The period of time provided for Office Owner to complete the installation and construction of the improvements set forth in the Office Improvement Plans pursuant to this Agreement may be extended upon application by Office Owner and approval by the Director pursuant to Section 4(b) [Extensions] below.

(f) Transportation Improvements Requiring Plans and Specifications for Construction. MF Owner shall prepare and submit Plans and Specifications and a Cost Estimate for the construction of the transportation improvement identified in Condition of Approval 2.ss.iii (“**Chrysler/Independence Improvement**”), to City prior to the issuance of a superstructure permit from City to MF Owner for the construction of the Residential Component of the Project (“**Transportation Improvement Plans**”). The City shall diligently review and process Transportation Improvement Plans submitted by MF Owner. Within ninety (90) days following the issuance of a superstructure building permit for the construction of the Residential Component of the Project, MF Owner shall commence the installation and construction of the improvements

set forth in the Transportation Improvement Plans to be constructed by MF Owner in accordance with the Conditions of Approval and this Agreement. In the event MF Owner fails to timely commence the construction of the improvements set forth in the Transportation Improvement Plans as required herein, City may, in its discretion, issue and enforce a stop work notice on all or any portion of work being undertaken by MF Owner pursuant to any building permits issued by City for the construction of the Residential Component until construction of the improvements set forth in the Transportation Improvement Plans has commenced to the reasonable satisfaction of the Director or City Engineer.

MF Owner shall complete the installation and construction of the improvements set forth in the Transportation Improvement Plans in accordance with Section 6 (a) [Director's Inspection] below and City shall complete the Acceptance of the improvements set forth in the Transportation Improvement Plans in accordance with Section 6 (b) [Acceptance] upon the earlier of (i) twenty four (24) months following the commencement of the installation and construction of the improvements set forth in the Transportation Improvement Plans or (ii) issuance of a certificate of occupancy, inclusive of a temporary certificate of occupancy, from City for any portion of the Residential Component of the Project. The period of time provided for MF Owner to complete the installation and construction of the improvements set forth in the Transportation Improvement Plans pursuant to this Agreement may be extended upon application by MF Owner and approval by the Director pursuant to Section 4(b) [Extensions] below.

(g) Transportation Improvements Requiring Conceptual Plans, Cost Estimates and Fees Only. Notwithstanding anything else herein, the Parties acknowledge and agree that Condition of Approval 2.ss.i. (“**Chrysler/Bayfront Improvement**”) and 2.ss.ii. (“**Chrysler/Jefferson Improvement**”) (as further identified in Exhibit C) obligate MF Owner to provide conceptual plans and cost estimates for City approval and pay fair share fees without any obligation to construct either the Chrysler/Bayfront Improvement or Chrysler/Jefferson Improvement. MF Owner shall be required to provide conceptual plans and cost estimates for the Chrysler/Bayfront Improvement and Chrysler/Jefferson Improvement for City approval prior to issuance of a superstructure building permit from the City to MF Owner for the construction of the Residential Component of the Project. MF Owner shall pay fair share fees as identified in Exhibit C prior to issuance of a superstructure building permit for the construction of the Residential Component. In any event, MF Owner shall not be required to provide 100% plans and shall not be required to construct such improvements or otherwise comply with the terms of this Agreement relating to construction of improvements.

(h) Other Required Documentation.

(i) Prior to the issuance of a superstructure building permit from City to MF Owner for the construction of the Residential Component of the Project, MF Owner shall provide executed copies of all the documents, agreements and notices required pursuant to and set forth in **Exhibit D** and labeled as required pursuant to Section 2(h)(i), including the improvement security set forth in Section 3 and insurance coverage set forth in Section 9, with respect to the Chrysler/Independence Improvement and improvements set forth in the Residential Improvement Plans to be installed, constructed and completed by MF Owner in accordance with the Conditions of Approval, unless waived or deferred by the Director, in writing, until a time certain or the time of a request for a Notice of Completion pursuant to Section 6 (a) [Director’s Inspection] below.

The required documents shall include an (A) estimate of costs to construct and complete the improvements set forth in the Residential Improvement Plans plus a twenty five percent (25%) contingency (“**Multifamily Engineer’s Estimate**”) and (B), an estimate of costs to construct and complete the improvements set forth in the Transportation Improvement Plans plus a twenty five percent (25%) contingency (“**Transportation Engineer’s Estimate**”).

(ii) Prior to the earlier of (i) issuance of a final certificate of occupancy from City for the Residential Component of the Project, or (ii) issuance of a superstructure building permit from the City to Office Owner for the construction of the Office Component of the Project, Office Owner shall provide executed copies of all the documents, agreements and notices required pursuant to and set forth in **Exhibit D** and labeled as required pursuant to Section 2 (h)(ii), including the improvement security set forth in Section 3 and insurance coverage set forth in Section 9, with respect to the improvements set forth in the Office Improvement Plans to be installed, constructed and completed by Office Owner in accordance with the Conditions of Approval, unless waived or deferred by the Director, in writing, until a time certain or the time of a request for a Notice of Completion pursuant to Section 6 (a) [Director’s Inspection] below. The required documents shall include an estimate of costs to construct and complete the improvements set forth in the Office Improvement Plans plus a twenty five percent (25%) contingency (“**Office Engineer’s Estimate**”).

(iii) At the time of a request for a Notice of Completion for the improvements set forth in the Transportation Improvement Plans, Residential Improvement Plans or the Office Improvement Plans, as applicable, pursuant to Section 6 (a) [Director’s Inspection] below, Developers, as appropriate, shall provide all documents required pursuant to and set forth in **Exhibit E**, plus any other materials previously deferred by the Director pursuant to subsections 2 (h)(i) or 2(h)(ii) above, unless waived or deferred by the Director, in writing, until a time certain or the time of a request for Acceptance pursuant to Section 6 (b) below. The required documents shall include as-built plans of the completed improvements, or portion thereof, set forth in the Transportation Improvement Plans, Residential Improvement Plans and Office Improvement Plans, as applicable, in both electronic (in a reasonably current version of AutoCAD and/or another digital format acceptable to Public Works) and Mylar formats and any reports required by any related Plans and Specifications.

(iv) At the time of a request for Acceptance of the improvements set forth in the Transportation Improvement Plans, Residential Improvement Plans or the Office Improvement Plans, as applicable, pursuant to Section 6(b) below, Developers, as appropriate, shall provide all the documents required pursuant to and set forth in **Exhibit F**, plus any other materials previously deferred by the Director pursuant to subsections 2 (h)(i), 2 (h)(ii) and 2 (h)(iii) above, unless waived or deferred by the Director in writing. In addition, as part of compliance with this subsection 2 (h)(iv), Developers shall coordinate with the City and assist in the City’s process for the subsequent dedication and Acceptance of the improvements set forth in the Transportation Improvement Plans, Residential Improvement Plans and the Office Improvement Plan, as applicable by (A) providing necessary maps, legal descriptions and plats for street openings, proposed easements and/or dedications for right of way or utility purposes and for relinquishment of existing rights of access and utilities associated with on-site and off-site development, to the extent applicable, and (B) executing easement agreements or grant deeds or

modifying existing easements or grant deeds consistent with the Conditions of Approval, to the extent applicable.

(i) Labor Code Compliance. Developers shall carry out, and shall use their best efforts to ensure that their contractors and subcontractors carry out, the design, installation, construction and completion of the Off-Site Improvements and Chrysler/Independence Improvement in conformity with all applicable State of California Labor Code requirements; the City zoning and development standards; building, plumbing, mechanical and electrical codes; all other provisions of the City of Menlo Park Municipal Code; and all applicable disabled and handicapped access requirements, including the Americans With Disabilities Act, 42 U.S.C. Section 12101, *et seq.*, Government Code Section 4450, *et seq.*, Government Code Section 11135, *et seq.*, and the Unruh Civil Rights Act, Civil Code Section 51, *et seq.*

Developers acknowledge and agree that the Off-Site Improvements and Chrysler/Independence Improvement constitute “public works” as defined in Labor Code section 1720. Developers shall be required to comply with prevailing wage requirements in connection with the design and construction of the Off-Site Improvements and Chrysler/Independence Improvement to the extent required by applicable State of California Labor Code requirements. Developers shall require the general contractor(s) for the Off-Site Improvements and Chrysler/Independence Improvement to post on the Property prevailing wage rates for all applicable trades and to submit certified copies of payroll records to Developers to ensure compliance with State of California Labor Code requirements pertaining to public works. Developers shall provide such payroll records to City within ten (10) days following City’s request therefor. Developers shall also include in their Construction Contract a provision obligating Developers’ contractor to require their contractors and/or subcontractors to comply with public works prevailing wage requirements.

Developers shall defend, with counsel reasonably acceptable to City, indemnify and hold harmless City and Bay Cities Joint Powers Insurance Authority and their respective officials, officers, employees, agents and representatives (“**Indemnitees**”) from and against any and all liabilities, obligations, orders, claims, damages, governmental fines or penalties, and actual expenses of defense with respect thereto, including reasonable attorneys’ fees and costs (“**Claims**”) arising out of Developers’ failure to comply with State of California Labor Code requirements pertaining to the design and construction of the Off-Site Improvements and Chrysler/Independence Improvement. Further, Developers shall indemnify and hold harmless the Indemnitees with respect to all final judgments or settlements in actions brought by any “contractor” in which City is (i) determined to be an “awarding body” and (ii) damages are awarded, pursuant to Labor Code sections 1726 or 1781. Developers’ defense, indemnity and hold harmless obligations under this section shall survive expiration or termination of this Agreement.

Developers hereby waive, releases and discharges forever the Indemnitees from any and all present and future Claims arising out of or in any way connected with Developers’ obligation to comply with all State of California Labor Code requirements pertaining to the design,

installation, construction and completion of the Off-Site Improvements and Chrysler/Independence Improvement.

This release applies to all potential future claims and Developers, on behalf of themselves and their agents, representatives, assigns, heirs, spouses, successors-in-interest, executors, administrators, employees, contractors, subcontractors, material suppliers and vendors (“**Releasors**”), agree to waive any and all rights pursuant to Section 1542 of the California Civil Code, which reads as follows:

“A general release does not extend to claims that the creditor does not know or suspect to exist in his favor at the time of executing the release, which if known by him must have materially affected his settlement with the debtor.”

Developers shall include within each of their contracts, subcontracts, and within any other agreements with Releasors involved in the Work, a release in favor of the Indemnitees substantially identical to this Section 2 (i).

3. Improvement Security.

(a) Security: Residential Improvement Plans. Concurrent with the delivery of the documentation set forth in **Exhibit D** in accordance with the provisions of Section 2(h)(i), MF Owner shall furnish and deliver to the Director bonds, in favor of the City, substantially in the form attached as **Exhibits G-1** and **G-2** and approved by the City Attorney, from an issuer approved by the Director, securing the completion of the installation and construction of the improvements set forth in the Residential Improvement Plans, and payment for all labor, materials, equipment, and services required for the installation and construction of the improvements set forth in the Residential Improvement Plans, including any monuments as determined to be necessary by the Director or City Engineer, as follows:

(i) Performance bonds, substantially in the form attached as **Exhibit G-1**, and approved by the City Attorney, in the amount of the Multifamily Engineer's Estimate to secure the satisfactory performance of MF Owner's obligation to complete the installation and construction of the improvements set forth in the Residential Improvement Plans; further, as provided therein, upon Acceptance of the improvements set forth in the Residential Improvement Plans by City pursuant to Section 6 (b), the performance bond shall convert to a warranty bond in the amount of ten percent (10%) of the Multifamily Engineer's Estimate for a period of one (1) year to secure the Warranty Period provided in Section 8(a) below; and

(ii) Payment bonds, substantially in the form attached as **Exhibit G-2**, and approved by the City Attorney, in the amount of the Multifamily Engineer's Estimate to guarantee payment for the labor, materials, equipment, and services required for the installation, construction and completion of the improvements set forth in the Residential Improvement Plans.

(b) Security: Transportation Improvement Plans. Concurrent with the delivery of the documentation set forth in **Exhibit D** in accordance with the provisions of Section 2(h)(i), MF Owner shall furnish and deliver to the Director bonds, in favor of the City, in the form attached as **Exhibits G-1** and **G-2** and approved by the City Attorney, from an issuer approved by the

Director, securing the completion of the installation and construction of the improvements set forth in the Transportation Improvement Plans, and payment for all labor, materials, equipment, and services required for the installation and construction of the improvements set forth in the Transportation Improvement Plans, including any monuments as determined to be necessary by the Director or City Engineer, as follows:

(i) Performance bonds, substantially in the form attached as **Exhibit G-1** and approved by the City Attorney, in the amount of the Transportation Engineer's Estimate for the installation, construction and completion of the improvements set forth in the Transportation Improvement Plans, to secure the satisfactory performance of MF Owner's obligation to complete the installation and construction of the improvements set forth in the Transportation Improvement Plans; further, as provided therein, upon Acceptance of the improvements set forth in the Transportation Improvement Plans by City pursuant to Section 6 (b), the performance bond shall convert to a warranty bond in the amount of ten percent (10%) of the Transportation Engineer's Estimate for a period of one (1) year to secure the Warranty Period provided in Section 8(a) below; and

(ii) Payment bonds, substantially in the form attached as **Exhibit G-2**, and approved by the City Attorney, in the amount of the Transportation Engineer's Estimate to guarantee payment for the labor, materials, equipment, and services required for the installation, construction and completion of the improvements set forth in the Transportation Improvement Plans.

(c) **Security: Office Improvement Plans.** Concurrent with the delivery of the documentation set forth in **Exhibit D** in accordance with the provisions of Section 2(h)(ii), Office Owner shall furnish and deliver to the Director bonds, in favor of the City, substantially in the form attached as **Exhibits G-1** and **G-2** and approved by the City Attorney, from an issuer approved by the Director, securing the completion of the installation and construction of the improvements set forth in the Office Improvement Plans, and payment for all labor, materials, equipment, and services required for the installation and construction of the improvements set forth in the Office Improvement Plans, including any monuments as determined to be necessary by the Director or City Engineer, as follows:

(i) Performance bonds, substantially in the form attached as **Exhibit G-1** and approved by the City Attorney, in the amount of the Office Engineer's Estimate for the installation, construction and completion of the improvements set forth in the Office Improvement Plans, to secure the satisfactory performance of Office Owner's obligation to complete the installation and construction of the improvements set forth in the Office Improvement Plans; further, as provided therein, upon Acceptance of the improvements set forth in the Office Improvement Plans by City pursuant to Section 6 (b), the performance bond shall convert to a warranty bond in the amount of ten percent (10%) of the Office Engineer's Estimate for a period of one (1) year to secure the Warranty Period provided in Section 8(a) below; and

(ii) Payment bonds, substantially in the form attached as **Exhibit G-2**, and approved by the City Attorney, in the amount of Office Engineer's Estimate, to guarantee payment for the labor, materials, equipment, and services required for the installation, construction and completion of the improvements set forth in the Office Improvement Plans.

(d) Use of Security. Any security provided under Section 3 (a), 3 (b) and 3 (c) shall be referred to collectively as the “**Security**”. If the installation and construction of the improvements set forth in the Residential Improvement Plans, Office Improvement Plans or Transportation Improvement Plans are not completed within the time periods specified in Section 2 (c), 2 (e), or 2 (f), respectively, and such period is not extended by the City or as otherwise provided under this Agreement, or Developers have not satisfactorily corrected all deficiencies during the Warranty Period (as defined below), the Security may, as determined by the Director, be used by the City for completion of the installation and construction of the improvements set forth in and in accordance with the Residential Improvement Plans, Office Improvement Plans or Transportation Improvement Plans and for the correction of any such deficiencies.

4. Construction of the Off-Site Improvements and Chrysler/Independence Improvement.

(a) Permits and Fees. Developers shall not perform any work on the Off-Site Improvements or Chrysler/Independence Improvement until all required permits have been obtained for the portion of work involved, all applicable fees, including but not limited to, encroachment permit, building permit, plan check, inspection and testing fees, have been paid to City. In addition, no work shall commence until the Developers have submitted to the City and City has approved all required items described in Section 2 (h), as applicable, and any additional requirements of and authorizations specified in the Code, Conditions of Approval, and this Agreement, unless the Director, in his or her discretion, has granted a written waiver or deferral for one or more of these materials.

Developers acknowledge that City may inspect the construction of the Off-Site Improvements and Chrysler/Independence Improvement and agree to pay costs incurred by City for these inspection services. Costs of inspection services include, but are not limited to, checking of maps and plans, field checking, inspection and testing conducted by City staff and/or agents or consultants contracted by City to perform such services. City staff, agents and consultants shall at all times during construction of the Off-Site Improvements and Chrysler/Independence Improvement have access to the work.

(b) Extensions. The Developers may request an extension of the time period specified in Sections 2 (c), 2 (e), or 2 (f) for completion of the installation and construction of the Off-Site Improvements and Chrysler/Independence Improvement by written request to the Director. A request shall include satisfactory evidence, as determined by the Director, to justify the extension, and shall be made upon the Director’s determination that Developers cannot reasonably meet the deadline in the time remaining for completion. The Director may request additional information, and shall in good faith attempt to determine within thirty (30) days of the request whether to grant an extension of time. The Director’s failure to respond within the time specified shall, however, not constitute either a grant or denial of the requested extension. The Director shall not unreasonably withhold a request for an extension. The Director may reasonably condition an extension subject to the terms of this Agreement and the conditions provided in the Code, including execution of an extension agreement and the extension of any security. No extension approved hereunder shall limit or relieve a surety’s liability, or provide an extension on any future obligation under this Agreement.

(c) Revisions to Plans and Specifications. Requests by the Developers for revisions, modifications, or amendments to the approved Residential Improvement Plans, Office Improvement Plans or Transportation Improvement Plans (each a “**Plan Revision**”) shall be submitted in writing to the Director (with a copy to the Director’s designee). Developers shall not commence construction of any proposed Plan Revision without approval by Public Works and until revised plans have been received and approved by the Director (or the Director’s designee) in writing.

(i) Any documentation required for a Plan Revision shall be processed with reasonable promptness, and approval of the Plan Revision shall not be deemed final until the amendment or other documentation has been completed.

(ii) Any Plan Revision request shall be accompanied by (A) a statement explaining the need for or purpose of the proposed revision, and (B) drawings and specifications and other related documents showing the proposed Plan Revision in reasonable detail, consistent with the original Plans and Specifications.

5. Release of Security. The Security, or any portions thereof, not required to secure completion of Developers’ obligation for construction or installation of Off-Site Improvements and Chrysler/Independence Improvement to satisfy claims by contractors, subcontractors, and/or persons furnishing materials or equipment, or for setting monuments, shall be released to the Developers, or their successors in interest, or reduced, pursuant to the procedures below as appropriate:

(a) Warranty Bond. Upon the Acceptance of Off-Site Improvements and Chrysler/Independence Improvement in accordance with Section 6 (a), the Security shall be reduced as to that portion of Off-Site Improvements and Chrysler/Independence Improvement in accordance with Section 3 (a)(i), 3 (b)(i) and 3 (c)(i). As to that portion of Off-Site Improvements and Chrysler/Independence Improvement, the Security remaining following such reduction is referred to herein as the “**Remaining Security**,” which term shall also refer to all Security remaining after any release under this Subsection following the Director’s issuance of a Notice of Completion for the final portion of Off-Site Improvements and Chrysler/Independence Improvement.

(b) Partial Release of Security. Notwithstanding the release provisions in Section 5 (a) and except as provided in Section 5 (c), the Security as required by Section 3 may be reduced in conjunction with completion of any portion of Off-Site Improvements and Chrysler/Independence Improvement to the satisfaction of the Director in compliance with Section 6(a) to an amount determined by the Director that equals the actual cost of the completed portion of Off-Site Improvements and Chrysler/Independence Improvement. Prior to the date that the conditions set forth in Section 5(c) are satisfied, in no event, however, shall the amount of the Security be reduced below the greater of (i) the amount required to guarantee the completion of the remaining portion of Off-Site Improvements and Chrysler/Independence Improvement and any other obligation imposed by the Subdivision Map Act, if applicable, the Code, Conditions of Approval or this Agreement; or (ii) the warranty bond totaling ten percent (10%) of the original bond amount.

(c) Release of Remaining Security. Remaining Security shall be released when all of the following have occurred:

(i) One (1) year following the date of Acceptance (as defined below) of (or, as appropriate, a Certificate of Conformity) regarding the relevant portion of Off-Site Improvements and Chrysler/Independence Improvement, or, with respect to any specific claim of defects or deficiency in Off-Site Improvements and Chrysler/Independence Improvement (excepting therefrom normal wear and tear) after such has been Accepted, one (1) year following the date that any such defect or deficiency which the Director identified in the Off-Site Improvements and Chrysler/Independence Improvement in accordance with Section 6 (a) has been corrected or waived in writing by the Director; and

(ii) The City Clerk (or the Clerk's designee) certifies that no claims by any contractor, subcontractor or person furnishing labor, materials or equipment for the Off-Site Improvements and Chrysler/Independence Improvement have been filed with the City, or all such claims have been satisfied, withdrawn, or otherwise secured by bond or other security provided by Developers and approved by the Director (or the Director's designee).

6. Completion and Acceptance.

(a) Director's Inspection. No sooner than ninety (90) days prior to the date that Developers intend for the Director to issue a Notice of Completion, Developers shall make a written request to the Director of the Developers' intent to initiate the Notice of Completion process ("**Letter of Intent to Request Notice of Completion**"). Upon written request from the Developers for a "**Notice of Completion**", accompanied with any and all materials that are required under Section 2 (h)(iii) [Other Required Documentation] related to the Notice of Completion and any other materials that the Director deferred in writing pursuant to Section 2 (h)(i) or 2 (h)(ii), other than those materials that the Director has deferred until Acceptance, the Director shall initiate the inspection. If the Developers fails to submit a Letter of Intent to Request Notice of Completion, the Director need not consider the Developers' request for the Director's issuance of a Notice of Completion until such a Letter of Intent to Request Notice of Completion is submitted to the Director and ninety (90) days have passed from the submission of the Letter; provided, however, that the Director, in his or her discretion, may agree in writing to a period of less than ninety (90) days from receipt of the Letter to consider issuance of a Notice of Completion. If the Director determines that the Off-Site Improvements and Chrysler/Independence Improvement have not been completed or does not satisfy the above requirements, Director shall notify Developers of such determination together with a statement setting forth with particularity the basis for that determination. If the Director determines that the Off-Site Improvements and Chrysler/Independence Improvement has been completed and meets the above requirements, the Director shall issue the Notice of Completion. For the sake of clarity, the Developers may submit separate requests for Notices of Completion for the improvements set forth in the Residential Improvement Plans, improvements set forth in the Transportation Improvement Plans and improvements set forth in the Office Improvement Plans. Requests to further separate Notices of Completion for separate scopes of work shall be subject to the Director's approval.

(b) Acceptance. “**Acceptance**” by the City of the Off-Site Improvements and Chrysler/Independence Improvement, or portion thereof, for public use and maintenance shall be deemed to have occurred when:

(i) The Director has issued a Notice of Completion for the Off-Site Improvements and Chrysler/Independence Improvement, or portion thereof, in accordance with Section 6 (a);

(ii) The Developers submit a written request to the Director to accept the Off-Site Improvements and Chrysler/Independence Improvement. Such submission shall include all materials required by Section 2 (h)(iv) and all materials for which the Director authorized deferral under Sections 2 (h)(i), 2 (h)(ii) and 2 (h)(iii); and

(iii) The Director, in writing, accepts the Off-Site Improvements and Chrysler/Independence Improvement, or portion thereof, for public use and maintenance in accordance with the Code and Developers’ warranty obligations under Section 8(a) of this Agreement.

(c) Offers of Dedication. The Public Works Director shall accept, conditionally accept, or reject for public right-of-way and utility purposes the Off-Site Improvements and Chrysler/Independence Improvement (or a portion of the Off-Site Improvements and Chrysler/Independence Improvement) in accordance with Subsection 6 (b).

7. Developers’ Maintenance Responsibility.

(a) General Maintenance and Liability Prior to Acceptance. Prior to Acceptance, Developers shall be responsible for the maintenance and repair of the Off-Site Improvements and Chrysler/Independence Improvement and shall bear the liability regarding the same consistent with the Code.

(b) Maintenance and Liability Following Acceptance. Following Acceptance of Off-Site Improvements and Chrysler/Independence Improvement and subject to Section 8 (a), the City shall assume the responsibility of operating and maintaining and shall be liable for such Off-Site Improvements and Chrysler/Independence Improvement. Without limiting the generality of the foregoing, nothing in this Agreement shall be construed to mean that Developers are responsible (or that City shall have right to call upon the Security) for the repair, replacement, restoration, or maintenance of the Off-Site Improvements and Chrysler/Independence Improvement damaged by the actions of third parties following Acceptance by the City or by ordinary wear and tear or harm or damage from improper maintenance or operation of the Off-Site Improvements and Chrysler/Independence Improvement by the City, or any agent or agency of either. Furthermore, without limiting the generality of the foregoing, nothing in this Agreement shall be construed to mean that Developers do not retain responsibility for maintenance and repair of “sidewalks” and “walkways”, as defined in California Streets and Highways Code §5600 and Menlo Park Municipal Code §13.08.010, respectively, constructed as part of the Off-Site Improvements, pursuant to California Streets and Highways Code §5600 *et seq.* and Chapter 13.08 of Title 13 of the Code, as said provisions may be amended from time to time.

(c) Protection of Off-Site Improvements and Chrysler/Independence Improvement. Developers may, but shall not be obligated to, allow access by the public to portions of the Off-Site Improvements and Chrysler/Independence Improvement that have been constructed but not Accepted. In order to protect the Off-Site Improvements and Chrysler/Independence Improvement from damage and to minimize Developers' exposure to liability until such time as the applicable Off-Site Improvements and Chrysler/Independence Improvement, or portion thereof, is Accepted, Developers may erect a construction fence or other physical barrier around areas under construction, to be constructed in the future, or constructed but not Accepted, provided that Developers have procured all necessary permits and complied with all applicable laws. However, no construction fence or other physical barrier may be built or maintained if the Director determines that a construction fence or other physical barrier adversely affects public health or safety by unreasonably restricting the ingress and egress of the public to and from a public right of way. For purposes of the preceding sentence, if there exists an alternative means of ingress and egress other than the Off-Site Improvements and Chrysler/Independence Improvement, then the Director may not determine that the construction fence or other physical barrier constitutes an unreasonable restriction of ingress and egress of the public to and from a public right of way.

8. Warranty and Indemnity.

(a) Warranty. Acceptance of Off-Site Improvements and Chrysler/Independence Improvement by the City shall not constitute a waiver of any defects. Separate and apart from any warranty provided at law, Developers covenant that all Off-Site Improvements and Chrysler/Independence Improvement constructed or installed by Developers shall be free from defects in material or workmanship and shall perform satisfactorily for a period (a "**Warranty Period**") of one (1) year for all portions of the Off-Site Improvements and Chrysler/Independence Improvement. Such Warranty Period shall begin upon the Acceptance of the Off-Site Improvements and Chrysler/Independence Improvement (or portion thereof), except that the Warranty Period for plant materials and trees planted as part of the Off-Site Improvements and Chrysler/Independence Improvement shall not commence until the plant establishment period set in accordance with the Residential Improvement Plans, Office Improvement Plans and Transportation Improvement Plans has satisfactorily passed. During the Warranty Period, Developers shall, as necessary, and upon receipt of a request in writing from the Director that defective work be corrected, inspect, correct, repair or replace any defects in the Off-Site Improvements and Chrysler/Independence Improvement (excepting therefrom normal wear and tear) at their own expense. Should Developers fail to act with reasonable promptness to make such inspection, correction, repair or replacement, or should an emergency require that inspection, correction, repair or replacement be made before Developers can be notified (or prior to Developers' ability to respond after notice), the City may, at their option, upon notice to Developers, make the necessary inspection, correction, repair or replacement or otherwise perform the necessary work and Developers shall reimburse the City for the actual cost thereof. During the Warranty Period, the City shall hold the Developers' Security, reduced as described in Section 5, to secure performance of Developers' foregoing warranty obligations. Developers' responsibility during the Warranty Period shall include repairing defects and defective material or workmanship, but not ordinary wear and tear or harm or damage from improper maintenance or operation of the Off-Site Improvements and Chrysler/Independence Improvement by the City, or any agent or agency of either.

(b) Indemnification of City. Developers, their successors and assigns, shall defend and indemnify the Indemnitees from and against any and all loss, cost, damage, injury, liability, and claims (“Losses”) to the extent arising from Developers’ breach of or negligent performance (or nonperformance) of this Agreement, except to the extent that such indemnity is void or otherwise unenforceable under applicable law, and except to the extent such Loss is the result of the gross negligence or willful misconduct of City, and further provided that any demand for indemnification hereunder with respect to negligent or defective construction must be brought, if at all, within one (1) year after expiration of the Warranty Period applicable to the Off-Site Improvements, or portion thereof. The foregoing indemnity shall include, without limitation, reasonable fees of attorneys, consultants and experts and related costs, and the City’s cost of investigating any claims against the City.

(c) Limitation on City Liability. The City shall not be an insurer or surety for the design or construction of the Off-Site Improvements and Chrysler/Independence Improvement pursuant to the approved Residential Improvement Plans, Office Improvement Plans and Transportation Improvement Plans, nor shall any officer or employee thereof be liable or responsible for any accident, loss, or damage happening or occurring during the construction of the Off-Site Improvements and Chrysler/Independence Improvement as specified in this Agreement, except as may arise due to the gross negligence or willful acts or omissions of the City.

9. Insurance. Prior to performing any Work pursuant to this Agreement, Developers shall, at their sole cost and expense, procure and maintain in effect, or cause to be procured and maintained in effect by contractor performing said Work, insurance coverage for general liability, automobile liability, workers compensation, pollution liability and Builder’s Risk against claims which may arise out of or result from the design, installation, construction and completion of the Off-Site Improvements by Developers, their agents, employees and contractors. Concurrent with the delivery of the documentation set forth in Exhibit D in accordance with the provisions of Section 2(h)(i) and 2 (h)(ii), Developers shall deliver to City one or more certificates of coverage, with the appropriate endorsements outlined below. The insurance policies shall be provided by a financially responsible insurance company authorized to write business in the State of California and have, at all times, a Best’s rating of “A- VII” (A minus VII) or better by AM Best & Company, and with coverage and policy limits as follows:

(i) The general liability insurance coverage shall have a per occurrence limit of two million and 00/100 dollars (\$2,000,000.00) and an aggregate limit of at least five million and 00/100 dollars (\$5,000,000.00), and shall be endorsed to (a) include the Indemnitees as additional covered parties providing all required coverages including coverages for both ongoing and completed operations, (b) stipulate that such coverage is primary and is not excess of, or contributing with, any other insurance carried by, or for the benefit of the Indemnitees, (c) apply separately to each insured and additional insured against whom claim is made or suit is brought, except with respect to the limits of the insurer’s liability, (d) waive any and all right of subrogation against the Indemnitees, and (e) contain a cross liability/severability endorsement (unless the base policy contains a separation of insureds clause accomplishing the same result);

(ii) The auto liability insurance coverage shall cover all owned, hired and non-owned vehicles utilized in connection with the construction of the Off-Site Improvements with a per

occurrence limit of two million and 00/100 dollars (\$2,000,000.00) and an aggregate limit of not less than five million and 00/100 dollars (\$5,000,000.00), and shall be endorsed to (a) include the Indemnitees as additional covered parties, (b) stipulate that such coverage is primary and is not excess of, or contributing with, any other insurance carried by, or for the benefit of the Indemnitees, (c) apply separately to each insured and additional covered parties against whom claim is made or suit is brought, except with respect to the limits of the insurer's liability, (d) waive any and all right of subrogation against the Indemnitees, and (e) contain a cross liability/severability endorsement (unless the base policy contains a separation of insureds clause accomplishing the same result);

(iii) Worker's Compensation insurance as required by the State of California which shall be endorsed to waive any and all rights of subrogation against the Indemnitees; further, any and all subcontractors shall maintain insurance coverage limits in accordance with state statute which shall also be endorsed to waive any and all rights of subrogation against the Indemnitees;

(iv) Pollution liability coverage shall have coverage limits of not less than \$2,000,000 for each claim arising from the discharge, dispersal, release or escape of any irritant or contaminant into or upon land, any structure, the atmosphere, watercourse or body of water, including groundwater; coverage shall include on and off-site clean up and emergency response costs and claims arising from above ground and below ground storage tanks; and

(v) Builder's Risk property insurance (either directly or through Developers' general contractor) on all buildings, structures, improvements, materials and real property on site, that are intended to be, or have already been incorporated into and forming part of the Work. Such coverage shall be on a builder's risk "special perils" or equivalent policy form in an amount not less than the Multifamily Engineer's Estimate, the Transportation Engineer's Estimate and Office Engineer's Estimate, plus the value of subsequent contract modifications and the cost of the materials supplied or installed by others, comprising the total value of the Work on a replacement cost basis, with a deductible not to exceed \$100,000.00. Such property insurance shall be maintained for the Work, unless otherwise agreed in writing by City. This insurance shall include the interests of City and the other Indemnitees, Developers, Developers' contractor and subcontractors on the Work. City shall further have the right to review and reasonably approve the form of Builder's Risk policy.

10. Miscellaneous.

(a) Relationship Between the Parties; Authority; Binding Effect. In performing their obligations under this Agreement, the Developers are an independent contractor and not an agent or employee of the City. This Agreement does not create any partnership or agency between the Parties, each of which is, and at all times shall remain, solely responsible for all acts of its officials, employees, agents, contractors and any subcontractors, including any negligent acts or omissions. No Party is an agent of the other, and has no authority to act on behalf of or to bind the other Party to any obligation whatsoever. Each Party executing this Agreement on behalf of a Party represents and warrants that such person is duly and validly authorized to do so on behalf of the entity it purports to bind. Each of the terms, covenants and conditions of this Agreement shall extend to and be binding on and shall inure to the benefit the Parties and each of their respective successors and assigns and all those taking by, under or through it or them.

(b) Venue; Attorneys' Fees. In the event that any action is brought by either Party hereto as against the other Party for the enforcement or declaration of any right or remedy in or under this Agreement or for the breach of any covenant or condition of this Agreement, venue for any such proceeding shall be in the Superior Court of the County of San Mateo, State of California. Should any party hereto institute any action or proceeding in court or other dispute resolution mechanism (“**DRM**”) to enforce any provision hereof by reason of an alleged breach of any provision of this Agreement, the prevailing party shall be entitled to receive from the losing party, court or DRM costs or expenses incurred by the prevailing party including, without limitation, expert witness fees, document copying expenses, exhibit preparation costs, carrier expenses and postage and communication expenses, and such amount as the court or DRM may adjudge to be reasonable attorneys’ fees for the services rendered the prevailing party in such action or proceeding. Attorneys’ fees under this Section 10 (b) include attorneys’ fees on any appeal, and, in addition, a party entitled to attorneys’ fees shall be entitled to all other reasonable costs and expenses incurred in connection with such action.

(c) Notices.

(i) A notice or communication under this Agreement by either Party to the other (or by or to the Director) shall be sufficiently given or delivered if dispatched by hand or by registered or certified mail, postage prepaid, or via electronic mail, addressed as follows:

In the case of a notice or communication to the Public Works Director:

City of Menlo Park
701 Laurel Street
Menlo Park, CA 94025-3483
Attn: Nicole H. Nagaya, Public Works Director
Reference: Menlo Portal
Email: nhnagaya@menlopark.org

With copies to:

Office of the City Attorney
c/o Burke, Williams & Sorensen, LLP
181 Third Street, Suite 200
San Rafael, CA 94901-6587
Attn: Nira Doherty, City Attorney
Reference: Menlo Portal
Email: NDoherty@bwslaw.com

And in the case of a notice or communication to the Developer:

GS MP Portal Owner, LLC
450 Sansome Street, Suite 500
San Francisco, CA 94111
Attn: Chad Zakskorn
Email: Chad Zakskorn <czakskorn@greystar.com>

With copies to:

Chelsea Maclean
Holland & Knight, LLP
50 California Street, Suite 2800
San Francisco, CA 94111
Email: chelsea.maclean@hkllaw.com

(ii) Any mailing address may be changed at any time by giving written notice of such change in the manner provided above at least ten (10) days prior to the effective date of the change. All notices under this Agreement shall be deemed given, received, made or communicated on the date personal receipt actually occurs or, if mailed, on the delivery date or attempted delivery date shown on the return receipt or, if by electronic mail transmission, on the date when sent provided that the sender receives no notice of non-delivery.

(d) Successors and Assigns. This Agreement shall be binding upon and inure to the benefit of the permitted successors and assigns of the Parties hereto, and upon such transfer in accordance with the provisions set forth herein, the Developers shall be released from their obligations hereunder. Any assignment of Developers' rights and obligations under this Agreement shall be in writing between City, Developers and their assignee, shall clearly identify the scope of the rights and/or obligations assigned and shall be subject to the approval of the Director and City Attorney, including, but not limited to, the requirement that the assignee provides replacement bonds that are consistent with **Exhibits G-1** and **G-2** in an amount required to secure any remaining obligations as approved by City, the assignee provides proof of adequate insurance in the amount previously provided by Developers and by an insurer with an equal or better credit rating, and the assignee has obtained all rights, title and interest in and to the Property and any other real estate rights reasonably required to satisfy all other conditions required to complete the Work contemplated by this Agreement.

(e) Legal and Equitable Relief. Each Party shall have the right (but not the obligation) to prosecute any proceedings at law or in equity against any other Party, or any other person or entity, violating or attempting to violate or defaulting in the performance of any of the provisions contained in this Agreement in order to prevent such party, person or entity from violating or attempting to violate or defaulting in the performance of any of the provisions of this Agreement or to recover damages for any such violation or default. It is agreed that damages would be an inadequate remedy for violation of this Agreement by any party and, therefore, injunctive or other appropriate equitable relief shall be available to the other party. The remedies

available under this Section 10 (e) shall include, by way of illustration but not limitation, ex parte applications for temporary restraining orders, preliminary injunctions and permanent injunctions enjoining any such violation or attempted violation or default, and actions for specific performance of this Agreement. The result of every action or omission whereby any covenant, condition or restriction herein contained is violated in whole or in part is hereby declared to be and to constitute a nuisance, and every remedy allowed by law or equity against any party, either public or private, shall be applicable against every such result and may be exercised by any party.

(f) Waiver. Failure by a Party to insist upon the strict performance of any of the provisions of this Agreement by another Party, or the failure by a Party to exercise its rights upon the default of another Party, shall not constitute a waiver of such Party's right to insist upon and demand strict compliance by the other Party with the terms of this Agreement thereafter.

(g) Parties in Interest. Nothing in this Agreement, expressed or implied, is intended to or shall be construed to confer upon or to give to any person or entity other than the City and the Developers, any rights, remedies or claims under or by reason of this Agreement or any covenants, conditions or stipulations hereof; and all covenants, conditions, promises, and agreements in this Agreement contained by or on behalf of the City, or the Developers shall be for the sole and exclusive benefit of the named Parties.

(h) Amendment. This Agreement may be amended, from time to time, by written supplement or amendment hereto and executed by the City and the Developers. The Director of Public Works, with the consent and approval of the City Attorney, is authorized to execute on behalf of the City any amendment that the Director determines is in the City's best interests and does not materially increase the City's obligations or materially diminish the City's rights under this Agreement. The foregoing notwithstanding, nothing herein shall preclude the Director from seeking and securing approval or concurrence of any amendment by the City Council.

(i) Counterparts. This Agreement may be executed in counterparts, each of which shall be deemed an original.

(j) Interpretation of Agreement. The recitals above and exhibits attached hereto are incorporated herein by reference and comprise part of this Agreement. This Agreement constitutes the entire agreement between the Parties with respect to the subject matter hereof and no prior oral or written understanding shall be of any force or effect with respect to the matters covered herein. The titles to the sections of this Agreement are not a part of this Agreement and shall have no effect upon the construction or interpretation of any part of this Agreement. As used in this Agreement, masculine, feminine or neuter gender and the singular or plural number shall each be deemed to include the others where and when the context so dictates. The word "including" shall be construed as if followed by the words "without limitation." This Agreement shall be interpreted as though prepared jointly by both Parties. The laws of the State of California, without regard to conflict of laws principles, shall govern the interpretation and enforcement of this Agreement. This Agreement shall be interpreted as though jointly prepared by both Parties.

(k) Severability. If any term, provision, condition or covenant of this Agreement or its application to any party or circumstances shall be held, to any extent, invalid or

unenforceable, the remainder of this Agreement, or the application of the term, provision, condition or covenant to persons or circumstances other than those as to whom or which it is held invalid or unenforceable, shall not be affected, and shall be valid and enforceable to the fullest extent permitted by law.

(l) Recording Agreement. This Agreement shall be recorded against the title of the Property.

(m) Purpose and Effect of Recording. This Agreement shall be recorded for the purpose of providing constructive notice to any future owner of the Property of Developers' obligations and responsibilities under this Agreement.

(n) Notice of Termination. At the time all the obligations and requirements specified in this Agreement are fully satisfied as determined by the Director of Public Works in consultation with affected City departments, the Parties shall execute and record (if applicable) a Notice of Termination.

IN WITNESS WHEREOF, the City, and MF Owner and Office Owner have executed this Agreement in one or more copies as of the day and year first above written.

[SIGNATURES ON NEXT PAGE]

MF Owner:

GS MP Portal Owner, LLC, a Delaware limited liability company

By: GS Menlo Portal Venture, LLC, a Delaware limited liability company, its Sole Member

By: GS MP Portal Manager, LLC, a Delaware limited liability company, its Manager

By: _____

Name: _____

Its: _____

Office Owner:

GS MP Portal Office Owner, LLC, a Delaware limited liability company

By: GS Menlo Portal Venture, LLC, a Delaware limited liability company, its Sole Member

By: GS MP Portal Manager, LLC, a Delaware limited liability company, its Manager

By: _____

Name: _____

Its: _____

CITY:

CITY OF MENLO PARK,
a municipal corporation

By: _____

Its: _____

APPROVED AS TO FORM:

CITY ATTORNEY

City Attorney

LIST OF EXHIBITS

- **Exhibit A-1**- Legal Description of Multifamily Property
- **Exhibit A-2** - Legal Description of Office Property
- **Exhibit B** - List of Off-Site Improvements
- **Exhibit C** - List of Transportation Improvements
- **Exhibit D** - Documents Required by City Pursuant to Section 2 (h)(i) and 2 (h)(ii)
- **Exhibit E** - Documents Required by City Pursuant to Section 2 (h)(iii) to Request Notice of Completion
- **Exhibit F** - Documents Required by City Pursuant to Section 2 (h)(iv) to Request Acceptance by Public Works Director
- **Exhibit G-1** - Performance Bond
- **Exhibit G-2** - Payment Bond

EXHIBIT A-1

Legal Description of Multifamily Property

All that real property situate in the City of Menlo Park, County of San Mateo, California, described as follows:

Being all of "MERGED PARCEL" as shown on that certain Lot Merger filed for record on December 17, 2021, as Document Number "2021-172942", Official Records of San Mateo County, being more particularly described as follows;

COMMENCING at the centerline monument located at the westerly terminus of the centerline of Constitution Drive as shown on said Map;

Thence along said centerline South 74°00'00" East, 192.31 feet;

Thence at a right angle South 16°00'00" West, 30.00 feet to the southerly right-of-way line of said Constitution Drive, and the **POINT OF BEGINNING** of this description;

Thence from said Point of Beginning, along said southerly right-of-way line, South 74°00'00" East, 277.23 feet to the most easterly corner of said Adjusted Parcel B;

Thence leaving said southerly right-of-way line, along the southeasterly line of said Adjusted Parcel B, South 22°35'00" West, 240.45 feet to the most southerly corner of said Adjusted Parcel B, said corner also being on the northeasterly line of Parcel B, as said parcel is shown on said Record of Survey;

Thence along said northeasterly line, North 67°25'00" West, 17.00 feet to the most easterly corner of said Parcel A;

Thence along the southeasterly, southwesterly, and northwesterly lines of said Parcel A, the following three (3) courses:

1. South 22°35'00" West, 223.44 feet to the most southerly corner of said Parcel A, and the northeasterly right-of-way line of Independence Drive, and the beginning of a non-tangent curve to the left, whose radius point bears South 27°52'44" West;

2. Northwesterly along said northeasterly right-of-way line, along said curve having a radius of 10,482.50 feet, through a central angle of $1^{\circ}00'14''$, for an arc length of 183.64 feet to the most westerly corner of said Parcel A;
3. Leaving said northeasterly right-of-way line, North $22^{\circ}35'00''$ East, 208.09 feet to the most northerly corner of said Parcel A, said corner also being the most easterly corner of said Adjusted Parcel B;

Thence along the southwesterly line of said Adjusted Parcel B, North $67^{\circ}25'00''$ West, 75.40 feet;

Thence leaving said southwesterly, North $22^{\circ}35'00''$ East, 208.66 feet to the **POINT OF BEGINNING**.

Containing 101,279 square feet or 2.33 acres, more or less.

END OF DESCRIPTION

EXHIBIT A-2

Legal Description of Office Property

All that real property situate in the City of Menlo Park, County of San Mateo, California, described as follows:

Being all of "ADJUSTED PARCEL A" as shown on that certain Lot Line Adjustment filed for record on December 16, 2021, as Document Number "2021-172539", Official Records of San Mateo County, being more particularly described as follows;

COMMENCING at the centerline monument located at the westerly terminus of the centerline of Constitution Drive as shown on said Map;

Thence along said centerline South 74°00'00" East, 192.31 feet;

Thence at a right angle South 16°00'00" West, 30.00 feet to the southerly right-of-way line of said Constitution Drive, and the **POINT OF BEGINNING** of this description;

Thence South 22°35'00" West, 208.66 feet to the southwesterly line of said Lot 7;

Thence along said southwesterly line, North 67°25'00" West, 178.13 feet to the most westerly corner of said Lot 7, said corner being on the easterly right-of-way line of Independence Drive, and also being the beginning of a non-tangent curve to the right, whose radius point bears South 85°56'43" East;

Thence along the westerly and northerly lines of said Lot 7 the following four (4) courses:

1. Northerly along said easterly right-of-way line, along said curve having a radius of 368.02 feet, through a central angle of 20°11'17", for an arc length of 129.67 feet;
2. North 24°14'34" East, 41.22 feet to the southerly right-of-way line of Constitution Drive and the beginning of a tangent curve to the right;
3. Along said southerly right-of-way line, along said curve having a radius of 20.00 feet, through a central angle of 81°45'26", for an arc length of 28.54 feet;

4. South 74°00'00" East, 179.34 feet to the **POINT OF BEGINNING**.

Containing 38,048 square feet or 0.87 acres, more or less.

This legal description was prepared by me or under my direction in conformance with the requirements of the Professional Land Surveyors' Act.

END OF DESCRIPTION

EXHIBIT B

List of Off-Site Improvements

Off-Site Improvements for Residential Component:

- Portion of Water Main Relocation on Constitution (Along MF Frontage)
- Portion of Gas Main Relocation on Constitution Drive (Along MF Frontage)
- Portion of Gas Main Relocation on Independence Drive (Along MF Frontage)
- Sewer Main Line Extension on Constitution
- Sewer Main Connection to 54" Sewer Trunk Line on Independence

Parcel Adjacent Improvements

- Asphalt Paving Improvements
- Concrete Improvements
- Sanitary Sewer
- Storm Drain
- Landscape and Irrigation
- Water
- Dry Utility
- Demolition
- Green Infrastructure

Off-Site Improvements for Office Component:

- Portion of Water Main Relocation on Constitution (Along Office Frontage)
- Portion of Gas Main Relocation on Constitution Drive (Along Office Frontage)

Parcel Adjacent Improvements

- Asphalt Paving Improvements
- Concrete Improvements
- Sanitary Sewer
- Storm Drain
- Landscape and Irrigation
- Water
- Dry Utility
- Demolition
- Green Infrastructure

EXHIBIT C

List of Transportation Improvements

Transportation Improvements:

Transportation Improvements Requiring Plans and Specifications for Construction:

Condition of Approval 2.ss.iii. (Chrysler and Independence) - Under the Near Term Scenario, the proposed improvement for the intersection of Chrysler Drive and Independence Drive is to install stop signs and necessary striping and pavement markings on Chrysler Drive. This improvement is not included in the City's TIF program. Simultaneous with the submittal of a complete building permit application for the Project, the applicant shall submit complete plans for this improvement. Complete plans shall include all necessary requirements to construct the improvements, including but not limited to striping modifications and a detailed cost estimate. The plans are subject to review by the City. Upon obtaining approval from the Director of Public Works or designee, the applicant shall construct the improvements prior to the granting of occupancy; further, the applicant and Director of Public Works shall identify in writing the final cost incurred by applicant to design and construct the improvement and the amount thereof in excess of applicant's proportional fair share obligation (the "**Reimbursement Amount**"). Any project(s) approved within 10 years of the approval date of the Project which are required to implement the same intersection improvement shall reimburse to the applicant an amount equal to said projects' proportional fair share of the Reimbursement Amount as determined by the City.

Transportation Improvements Requiring Conceptual Plans and Cost Estimates for Fees:

Condition of Approval 2.ss.i. (Chrysler and Bayfront) - Under the cumulative scenario, the proposed intersection improvements at the intersection of Chrysler Drive and Bayfront Expressway is to convert the existing right turn lane on Chrysler Drive to shared left/right-turn lane resulting in having two left-turn lanes and one shared left/right-turn lane in this direction. Simultaneous with the building permit submittal for the Residential Component of the Project, the applicant shall submit conceptual plans and a cost estimate (including design and construction engineering) for these improvements to the City for approval. This improvement is not included in the City's TIF program and is also subject to approval by Caltrans. The fair share contribution for the intersection improvements, calculated as 2.72% of the cost estimate, shall be paid prior to the issuance of the first building permit for the Project; construction of the improvement is not required. In the event that another development project submits conceptual plans and a construction cost estimate prior to submittal of a building permit application, payment of the project's fair share contribution shall be sufficient to satisfy this condition of approval. If these funds are not used within a 5-year period, they will be returned to the applicant.

Condition of Approval 2.ss.ii. (Chrysler and Jefferson) - Under the cumulative scenario, the proposed intersection modification at the intersection of Chrysler Drive and Jefferson Drive is to (i) install a traffic signal and (ii) convert the shared left/right lane to one left-turn lane and one right-turn lane on northbound Jefferson Drive. The installation of a traffic signal is consistent with

the City's Transportation Master Plan, which identifies traffic signal installation as a future improvement at the intersection of Chrysler Drive and Jefferson Drive. This improvement was studied and is included in the City's TIF program. The TIF payment will fulfill the requirement for improvement number (i). To fulfill the intersection improvement number (ii), the applicant shall provide a conceptual plan of the improvement and a cost estimate (including design and construction engineering) for approval by the City. The fair share contribution for the intersection improvement, calculated to be 7.45% of the cost estimate prepared to comply with this condition, shall be paid prior to issuance of the first building permit for the Project; construction of the improvement is not required. In the event that another development project submits conceptual plans and a construction cost estimate prior to submittal of a building permit application, payment of the project's fair share contribution shall be sufficient to satisfy this condition of approval. If these funds are not used within a 5-year period, they will be returned to the applicant.

EXHIBIT D

Documentation Required by City Pursuant to Sections 2 (h)(i) and 2 (h)(ii)

Residential Component Requirements Pursuant to Section 2 (h)(i)

1. Approved Residential Improvement Plans and Transportation Improvement Plans
2. Offer of dedication of Off-Site Improvements for the Residential Component from Developer to City upon Acceptance of Off-Site Improvements
3. Offer of dedication of Chrysler/Independence Improvement for the Project from Developer to City upon Acceptance of Chrysler/Independence Improvement
4. Offer of dedication of real property interests, if any, from Developer to City upon Acceptance of Off-Site Improvements and Chrysler/Independence Improvement
5. Deeds/public easement agreements, if necessary
6. Insurance Certificates
7. Multifamily Engineer's Estimate
8. Payment and Performance/Warranty Bonds in amount of Multifamily Engineer's Estimate and Transportation Engineer's Estimate, if required
9. Encroachment Permits for work in public right of way.

Office Component Requirements Pursuant to Section 2 (h)(ii)

1. Approved Office Improvement Plans
2. Offer of dedication of Off-Site Improvements for the Office Component from Developer to City upon Acceptance of Off-Site Improvements
3. Offer of dedication of real property interests, if any, from Developer to City upon Acceptance of Off-Site Improvements
4. Deeds/public easement agreements, if necessary
5. Insurance Certificates
6. Office Engineer's Estimate
7. Payment and Performance/Warranty Bonds in amount of Office Engineer's Estimate
8. Encroachment Permits for work in public right of way.

EXHIBIT E

Documentation Required by City Pursuant to Section 2 (h)(iii) to Request Notice of Completion

1. Developer Request Letter for Determination of Completeness (“DOC”)
2. Contractor Substantial Completion Letter
3. Civil Engineer Completion Notice
4. Geotechnical Engineer Completion Letter
5. Landscape Architect Completion Notice
6. City Final Punch-list Approval
7. Utility Conformance Letter (as applicable)
8. As-Built Plan Approval
9. Recorded Notice of Completion
10. Survey Monuments
11. Test Reports
12. Joint Trench Conduits mandrel test (as applicable)
13. Confirmation of Removal of all Non-Compliance Reports (“NCR”)
14. Confirmation of all Change Orders/Instructional Bulletins
15. Confirmation from City that Spare Parts have been provided (as applicable)
16. Operation and Maintenance Manuals (as applicable)
17. DOC Recommendation from Public Works

EXHIBIT F

Documentation Required by City Pursuant to Section 2 (h)(iv) to Request Acceptance by Public Works Director

1. Developer Request for Acceptance Letter
2. Lien Notification to General Contractor and Subs
3. Utility Bill of Sale (as applicable)
4. 3rd Party Reimbursement Checks-Copies
5. Assignment of Warranties and Guaranties
6. License Agreements (as applicable)
7. Mechanic's Lien Guarantee
8. Modified Offers of Off-Site Improvements (as applicable)
9. Updated Grant Deeds (as applicable)

EXHIBIT G-1

Performance/Warranty Bond

(Chapter 5, Division 2, Title 7 of California Government Code)

Bond no. _____

WHEREAS, the CITY OF MENLO PARK, a California municipal corporation (“**Owner**”), has approved the [*Residential Improvement Plans OR Office Improvement Plans (insert actual title of plans)*], prepared by [*Name of Engineering Firm*] and dated _____ (“**Improvement Plans**”), which improvements described therein are required to be constructed as set forth in that certain Public Improvement Agreement dated _____, 2022, by and between Owner and GS MP Portal Owner, LLC (“**Agreement**”); and

WHEREAS, [*insert name of developer*] (“**Developer**”) is required to furnish a bond in connection with the construction of the improvements shown on said Improvement Plans in the amount of the Engineer’s Estimate (as said term is defined in the Agreement) (\$_____) (“**Penal Sum**”) as security for the faithful performance of the work to be performed, which upon completion and acceptance of the constructed improvements by the Owner, converts to a warranty bond equal to ten (10%) of the Engineer’s Estimate (\$_____), for the warranty of the accepted improvements for a period of one (1) year; and

WHEREAS, this Bond consists of this page and the Bond Terms And Conditions, Paragraphs 1 through 14, attached to this page.

NOW, THEREFORE, we the undersigned Developer and, _____, as Surety are held and firmly bound unto the sum of _____dollars (\$_____) to be paid to the Owner, for which payment, we bind ourselves, jointly and severally.

[Signature Pages to Follow]

Dated: _____, 2022

DEVELOPER:

By: _____

Name: _____

Its: _____

SURETY:

[insert name of Surety]

By: _____

Attorney-in-fact

Correspondence or claims relating to this bond should be sent to the Surety at the following address:

Note: Signature of those executing for the Surety must be properly acknowledged, and a power of attorney attached.

CERTIFICATE OF ACKNOWLEDGMENT

State of California, County of San Mateo.

On this _____ day of _____ in the year 2022 before me, _____, personally appeared _____, personally known to me (or proved to me on the basis of satisfactory evidence) to be the person whose name is subscribed to this instrument as the attorney-in-fact of _____, and acknowledged to me that he (she) subscribed the name of the said company thereto as surety, and his (her) own name as attorney-in-fact.

(SEAL)

Notary Public

BOND TERMS AND CONDITIONS

1. Developer and Surety, jointly and severally, bind themselves, their heirs, executors, administrators, successors and assigns to Owner for the complete and proper performance of the Agreement, which is incorporated herein by reference.
2. If Developer completely and properly performs all of its obligations under the Agreement, Surety and Developer shall have no obligation under this Bond.
3. If there is no Owner Default, Surety's obligation under this Bond shall arise after:
 - 3.1 Owner provides Surety with written notice that Owner has declared a default under the Agreement pursuant to the terms of the Agreement.
4. When Owner has satisfied the conditions of Paragraph 3 above, Surety shall promptly (within forty (40) days) and at Surety's expense elect to take one of the following actions:
 - 4.1 Arrange for Developer, with consent of Owner, to perform and complete the Agreement (but Owner may withhold consent, in which case the Surety must elect an option described in Paragraphs 4.2, 4.3 or 4.4 below); or
 - 4.2 Undertake to perform and complete the Agreement itself, through its agents or through independent contractors or construction entities; provided, that Surety may not select Developer as its agent or independent contractor or Developer without Owner's consent; or
 - 4.3 Undertake to perform and complete the Agreement by obtaining bids from qualified contractors or Construction entities acceptable to Owner for a contract for performance and completion of the Agreement and, upon determination by Owner of the lowest responsive and responsible Bidder, arrange for a contract to be prepared for execution by Surety and the contractor or Developer selected with Owner's concurrence, to be secured with performance and payment bonds executed by a qualified surety equivalent to the bonds issued on the Agreement; or
 - 4.4 Waive its right to perform and complete, arrange for completion, or obtain a new contractor or Developer, and with reasonable promptness under the circumstances and, after investigation and consultation with Owner, determine in good faith its monetary obligation to Owner under Paragraph 6 below, for the performance and completion of the Agreement and, as soon as practicable after the amount is determined, tender payment therefor to Owner with full explanation of the payment's calculation. If Owner accepts Surety's tender under this Paragraph 4.4, Owner may still hold Surety liable for future damages then unknown or unliquidated resulting from the Developer's default, as agreed by Owner and Surety at the time of tender. If Owner disputes the amount of Surety's tender under this Paragraph 4.4, Owner may exercise all remedies available to it at law to enforce Surety's liability under Paragraphs 6 and 7 below.

5. At all times Owner shall be entitled to enforce any remedy available to Owner at law or under the Agreement including, without limitation, and by way of example only, rights to perform work, protect Work, mitigate damages, advance critical Work to mitigate schedule delay, and coordinate Work with other consultants or contractors.
6. If Surety elects to act under Paragraphs 4.1, 4.2 or 4.3 above, within the time period provided in Paragraph 4, above, and complies with its obligations under this Bond, Surety's obligations under this Bond are commensurate with Developer's obligations under the Agreement. Surety's obligations include, but are not limited to:
 - 6.1 Developer's obligations to complete the Agreement and correct Defective Work;
 - 6.2 Developer's obligations to pay liquidated damages, if applicable; and
 - 6.3 To the extent otherwise required of Developer under the Agreement, Developer's obligations to pay additional legal, design professional, and other costs not included within liquidated damages resulting from Developer Default (but excluding attorney's fees incurred to enforce this Bond).
7. If Surety does not elect to act under Paragraphs 4.1, 4.2, 4.3, or 4.4, above, within the time period provided in Paragraph 4, above, or comply with its obligations under this Bond, then Surety shall be deemed to be in default on this Bond ten Days after receipt of an additional written notice from Owner to Surety demanding that Surety perform its obligations under this Bond. Such Surety default shall be independent of the Developer Default. To the extent Surety's independent default causes Owner to suffer damages including, but not limited to, delay damages, which are different from, or in addition to (but not duplicative of) damages which Owner is entitled to receive under the Agreement, Surety shall also be liable for such damages. In the event any Surety obligation following its independent default is inconsistent or conflicts with California Civil Code Section 2809, or any other law which either prohibits, restricts, limits or modifies in any way any obligation of a surety which is larger in amount or in any other respect more burdensome than that of the principal, Surety hereby waives the provisions of such laws to that extent.
8. If Surety elects to act under Paragraphs 4.1, 4.3 or 4.4 above, within the time period provided in Paragraph 4, above, and complies with all obligations under this Bond, Surety's monetary obligation under this Bond is limited to the Penal Sum.
9. No right of action shall accrue on this Bond to any person or entity other than Owner or its successors or assigns.
10. Surety hereby waives notice of any change, alteration or addition to the Agreement or to related subcontracts, design agreements, purchase orders and other obligations, including changes of time, and of any Owner action in accordance with Paragraph 5 above. Surety consents to all terms of the Agreement, including provisions on changes to the Agreement. No extension of time, change, alteration, modification, deletion, or addition to the Agreement, Plans and Specifications, or of the work (including services) required thereunder, or any Owner action in accordance with Paragraph 5 above shall release or

exonerate Surety on this Bond or in any way affect the obligations of Surety on this Bond, unless such action is an Owner Default.

11. Any proceeding, legal or equitable, under this Bond shall be instituted in any court of competent jurisdiction where a proceeding is pending between Owner and Developer regarding the Agreement, or in the courts of the County of San Mateo, or in a court of competent jurisdiction in the location in which the work is located.
12. All notices to Surety or Developer shall be mailed or delivered (at the address set forth on the signature page of this Bond), and all notices to Owner shall be mailed or delivered as provided in the Agreement. Actual receipt of notice by Surety, Owner or Developer, however accomplished, shall be sufficient compliance as of the date received at the foregoing addresses.
13. Any provision in this Bond conflicting with any statutory or regulatory requirement shall be deemed deleted here from and provisions conforming to such statutory requirement shall be deemed incorporated herein.
14. Definitions
 - 14.1 Agreement: That certain Public Improvement Agreement dated _____, 2022, by and between Developer and Owner, including any amendments or addenda thereto.
 - 14.2 Developer Default: Material failure of Developer, which has neither been remedied nor waived, to perform or otherwise to comply with the terms of the Agreement.
 - 14.3 Owner Default: Material failure of Owner, which has neither been remedied nor waived, to perform material terms of the Agreement, if such failure is the cause of the asserted Developer Default.

END OF DOCUMENT

EXHIBIT G-2

Payment Bond

(Chapter 5, Title 3, Part 6, Division 4 of California Civil Code or Chapter 5, Division 2, Title 7 of California Government Code)

Bond No. _____

WHEREAS, the CITY OF MENLO PARK, a California municipal corporation (“**Owner**”), has approved the [*Residential Improvement Plans OR Office Improvement Plans (insert actual title of plans)*], prepared by [*Name of Engineering Firm*] and dated _____, 2022 (“**Improvement Plans**”), which improvements described therein are required to be constructed as set forth in that certain Public Improvement Agreement dated _____, 2022, by and between Owner and GS MP Portal Owner, LLC (“**Agreement**”); and

WHEREAS, [*insert name of developer*] (“**Developer**”) is required to furnish a Payment Bond in connection with said Agreement, to secure the payment of claims of laborers, mechanics, material men and other persons as provided by law.

NOW, THEREFORE, we, the undersigned Developer and _____, as Surety, are held and firmly bound unto Owner in the sum of the Engineer’s Estimate (as defined in the Agreement) (\$ _____) (“**Penal Sum**”), for which payment well and truly to be made we bind ourselves, our heirs, executors, administrators, successors, and assigns, jointly and severally, firmly by these presents.

THE CONDITION OF THIS OBLIGATION IS SUCH, that if Developer, or its executors, administrators, successors, or assigns approved by Owner, or its subcontractors shall fail to pay any of the persons named in California Civil Code Section 9100, or amounts due under the State of California Unemployment Insurance Code with respect to work or labor performed under the Agreement, or for any amounts required to be deducted, withheld, and paid over to the State of California Employment Development Department from the wages of employees of Developer and subcontractors pursuant to Section 13020 of the State of California Unemployment Insurance Code with respect to such work and labor, that Surety will pay for the same in an amount not exceeding the Penal Sum specified in this bond, plus reasonable attorneys’ fees, otherwise the above obligation shall become and be null and void.

This bond shall inure to the benefit of any of the persons named in California Civil Code Section 9100, as to give a right of action to such persons or their assigns in any suit brought upon this bond. The intent of this bond is to comply with the California Mechanic’s Lien Law.

Surety, for value received, hereby expressly agrees that no extension of time, change, modification, alteration, or addition to the undertakings, covenants, terms, conditions, and agreements of the Agreement, or to the work to be performed thereunder, shall in any way affect the obligation of

this bond; and it does hereby waive notice of any such extension of time, change, modification, alteration, or addition to the undertakings, covenants, terms, conditions, and agreements of the Agreement, or to the work to be performed thereunder.

Surety's obligations hereunder are independent of the obligations of any other surety for the payment of claims of laborers, mechanics, material suppliers, and other persons in connection with the Agreement; and suit may be brought against Surety and such other sureties, jointly and severally, or against any one or more of them, or against less than all of them without impairing Owner's rights against the other.

Correspondence or claims relating to this bond shall be sent to Surety at the address set forth below.

IN WITNESS WHEREOF, we have hereunto set our hands this _____ day of _____, 2022.

[Signature Pages to Follow]

Dated: _____, 2022

DEVELOPER:

By: _____

Name: _____

Its: _____

SURETY:

[insert name of Surety]

By: _____

Attorney-in-fact

Correspondence or claims relating to this bond should be sent to the Surety at the following address:

Note: Signature of those executing for the surety must be properly acknowledged, and a power of attorney attached.

CERTIFICATE OF ACKNOWLEDGMENT

State of California, County of San Mateo.

On this _____ day of _____ in the year 2022 before me, _____, personally appeared _____, personally known to me (or proved to me on the basis of satisfactory evidence) to be the person whose name is subscribed to this instrument as the attorney-in-fact of _____, and acknowledged to me that he (she) subscribed the name of the said company thereto as surety, and his (her) own name as attorney-in-fact.

(SEAL)

Notary Public



STAFF REPORT

City Council

Meeting Date:

9/13/2022

Staff Report Number:

22-173-CC

Public Hearing:

Adopt a resolution to abandon a public utility easement at 248 Oakhurst Place

Recommendation

Staff recommends that the City Council adopt a resolution (Attachment A) ordering the vacation and abandonment of a 10-foot-wide public utility easement (PUE) running through a portion of the existing structure at 248 Oakhurst Place.

Policy Issues

In order to abandon public easements, the City is legally required to go through a multistep process as specified by the State of California Streets and Highways Code or can abandon public easements through a tentative map as provided for in the Subdivision Map Act (California Government Code Section 66499.20.2.) In this case, the City is following the Streets and Highways Code process, for which there are two categories, standard and summary. Each process is specified by the Government Code, State of California, Streets and Highways Code, Section 8300. Section 8300 Subsection (a) of Section 8333 of the California Streets and Highways Code allows a summary vacation of easement that has not been used for the purpose for which it was dedicated or acquired for five consecutive years immediately preceding the proposed vacation. Summary vacations comprise a two-step process which requires a determination by the Planning Commission, and final action taken by the City Council.

Background

On April 20, 2021, the owner of 248 Oakhurst requested a use permit to construct a second-floor addition and perform interior and exterior modifications to an existing nonconforming, single-story, single-family residence in the R-1-U (Single Family Urban Residential) zoning district. The project plans showed a 10-foot-wide PUE running through a portion of the existing structure. A location map is included as Attachment B

The 10-foot-wide easement was dedicated as part of the Tract No. 560 Suburban Park Subdivision (Attachment C) and was never used by any utility companies. Utility companies have no objection to vacate this easement. The City requested that the applicant initiate the vacation of the 10-foot-wide PUE. The limits of vacation are precisely defined in Exhibit A to Attachment D and are subject to the summary vacation process as described below.

Analysis

The owner of the property at 248 Oakhurst Place has applied per the request of the City to initiate vacation of the 10-foot PUE running through a portion of the existing structure. The 10-foot PUE has no utilities and has never been used. Therefore, this PUE is no longer necessary for any future public purpose. The applicant has obtained approval (no-objection letters) from various utility companies including PG&E, AT&T,

Calwater and West Bay Sanitary District.

Abandonment procedure

Summary vacations require that the Planning Commission review the project for conformance with the General Plan and forward its determination to City Council for final action. On July 25, 2022, the Planning Commission determined that the proposed vacation was consistent with the General Plan (Attachment D.) Should the City Council consider the abandonment favorably, a resolution ordering the vacation and abandonment of the easement will be recorded. Staff recommends that the City Council adopt a resolution to abandon the PUE.

Impact on City Resources

There is no direct impact on City resources associated with the actions in this staff report. The fee for staff time to review and process the abandonment has been paid by the applicant.

Environmental Review

The summary vacation is Categorically Exempt under Class 15, Section 15305 (Minor Alterations in Land Use Limitations) of the current California Environmental Quality Act (CEQA) guidelines.

Public Notice

Public notification was achieved by posting the agenda, with the agenda items being listed, at least 72 hours prior to the meeting. Additionally, the public hearing was noticed in print newspaper, The Examiner, on September 2 and September 7, 2022.

Attachments

- A. Resolution to vacate and abandon PUE
- B. Location map
- C. Tract No. 560 Suburban Park subdivision
- D. Planning Commission resolution

Report prepared by:

Edress Rangeen, Associate Engineer

Report reviewed by:

Ebby Sohrabi, Senior Civil Engineer

Tanisha Werner, Assistant Public Works Director - Engineering

RESOLUTION NO. XXXX**RESOLUTION OF THE CITY COUNCIL OF THE CITY OF MENLO PARK
ORDERING THE VACATION AND ABANDONMENT OF PUBLIC UTILITY
EASEMENT RUNNING OVER A PORTION OF THE EXISTING STRUCTURE
AT 248 OAKHURST PLACE**

WHEREAS, on July 25, 2022, the City Planning Commission of the City of Menlo Park held a Public Hearing and adopted Planning Commission Resolution No. 2022-13 determining that the abandonment of Public Utility Easement running over a portion of the existing structure at 248 Oakhurst Place is consistent with the General Plan and has recommended that the City Council approve the requested vacation; and

WHEREAS, the 10-foot-wide easement was dedicated as part of the Tract No. 560 Suburban Park Subdivision and was never used by any utility companies. Utility companies have no objection to vacate this easement. The limits of vacation are precisely defined in Exhibit A and are subject to the summary vacation; and

WHEREAS, a Public Hearing was held before the City Council of the City of Menlo Park regarding the foregoing matter on September 13, 2022; and

WHEREAS, notice of said Public Hearing was duly made by publication, mailing, and posting as required by law, and proof thereof is on file with the City Clerk of the City of Menlo Park; and

WHEREAS, no protests were filed with or received by said City Council; and

NOW, THEREFORE, the City of Menlo Park, acting by and through its City Council, having considered and been fully advised in the matter and good cause appearing therefore, hereby finds and resolves that the Public Utility Easement should be vacated pursuant to subsection (a) of Section 8333 of the California Streets and Highways Code which allows a summary vacation of an easement that has not been used for the purpose for which it was dedicated or acquired for five consecutive years immediately preceding the proposed vacation and the easement to be vacated is not necessary for public use and there have been no objections provided to the proposed vacation by utility companies.

BE IT AND IT FURTHER RESOLVED by the City Council of the City of Menlo Park

- A) That this vacation is made pursuant to Division 9, Part 3, Chapter 4 of the California Streets and Highways Code, Section 8330 et seq.; and
- B) That the City Council has determined that the public interest, convenience and necessity require that the Public Utility Easement be vacated; and
- C) That the City Council does hereby order the vacation of the public utility easement within the property at 248 Oakhurst Place, described on the legal plats and more specifically shown in Exhibit A, attached hereto and incorporated herein by this reference and
- D) The City Clerk is directed and hereby shall cause a certified copy of this Resolution attested to by the Clerk under seal to be recorded with the San Mateo County Recorder, as required by Streets and Highways Code section 8336; and
- E) That said abandonment is consistent with the General Plan; and
- F) That said abandonment is exempt under current California Environmental Quality Act Guidelines.

I, Judi A. Herren, City Clerk of Menlo Park, do hereby certify that the above and foregoing City Council Resolution was duly and regularly passed and adopted at a meeting by said City Council on the thirteenth day of September, 2022, by the following votes:

AYES:

NOES:

ABSENT:

ABSTAIN:

IN WITNESS WHEREOF, I have hereunto set my hand and affixed the Official Seal of said City on this ___ day of September, 2022.

Judi A. Herren, City Clerk

Exhibits:

A. Public utility easement within the property at 248 Oakhurst Place

EXHIBIT "A"
LEGAL DESCRIPTION FOR
PUBLIC UTILITY EASEMENT VACATION
248 OAKHURST PLACE, MENLO PARK, CALIFORNIA

All that certain real property, situate in the City of Menlo Park, County of San Mateo, State of California, being part of the land of Loewke as described in that certain Grant Deed recorded May 8, 2020 as Instrument No. 2020-041334, Official Records of San Mateo County, and being a portion of Lots 9 and 10, Block 5 as shown on "Tract No. 560 Suburban Park", filed for record on July 17, 1946 in Book 25 of Maps at Pages 66 through 70, Records of San Mateo County, as shown on Exhibit "B" made a part hereof, more particularly described as follows:

Commencing at the most Westerly corner of said Lands, said point being the West corner of said Lot 9; thence along the westerly line of said Lands South $16^{\circ}55'22''$ East, 5.21 feet; thence leaving said line North $89^{\circ}34'38''$ East, 31.66 feet to the **Point of Beginning**; thence North $89^{\circ}34'38''$ East, 2.08 feet and North $84^{\circ}28'35''$ East, 12.05 feet; thence South $49^{\circ}42'24''$ East, 61.14 feet to a point on the northwesterly right of way of Oakhurst Place, 50 feet wide, as shown on said Map; thence along said right of way South $36^{\circ}21'15''$ West, 10.02 feet; thence leaving said line North $49^{\circ}42'24''$ West, 71.80 feet to the **Point of Beginning**.

Containing 664 square feet, more or less.

END OF DESCRIPTION



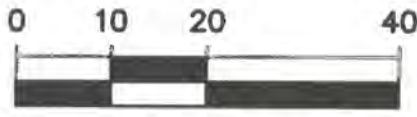
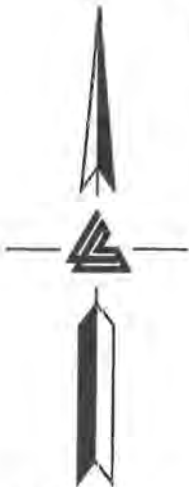
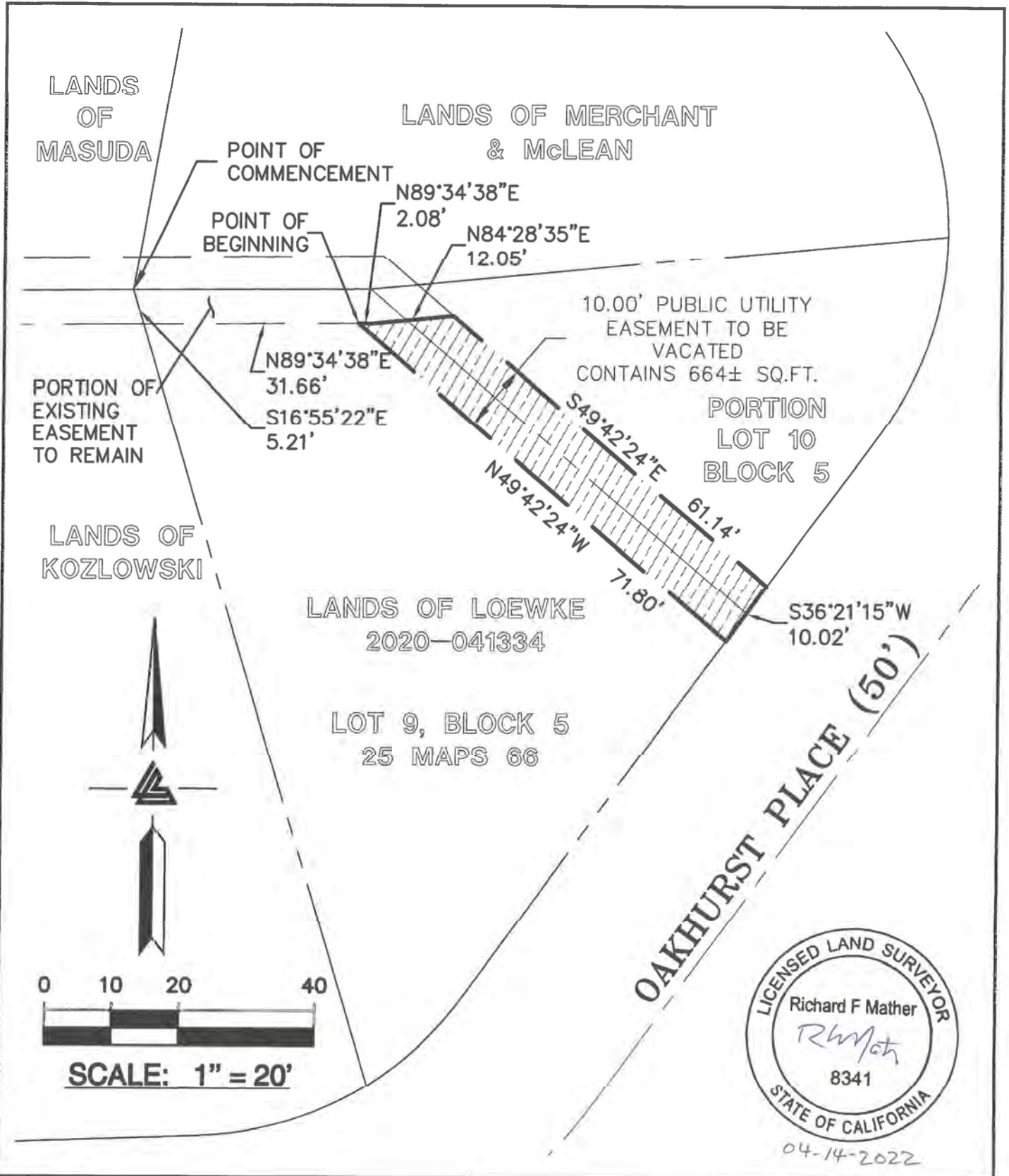

SCALE: 1" = 20'



04-14-2022

LEA & BRAZE ENGINEERING, INC.
 CIVIL ENGINEERS • LAND SURVEYORS

| | |
|---|--|
| BAY AREA REGION 2495 INDUSTRIAL PKWY WEST HAYWARD, CALIFORNIA 94545 (P) (510) 887-4086 (F) (510) 887-3019 WWW.LEABRAZE.COM | SACRAMENTO REGION 3017 DOUGLAS BLVD, # 300 ROSEVILLE, CA 95661 (P) (916)966-1338 (F) (916)797-7363 |
|---|--|

EXHIBIT 'B'
PLAT TO ACCOMPANY LEGAL
DESCRIPTION FOR PUBLIC UTILITY
EASEMENT VACATION
248 OAKHURST PLACE MENLO
PARK, CA

JOB NO 2200508 SCALE: 1" = 20'

North: 5377.3324' East: 4353.3404'

Segment #1 : Line

Course: N89° 34' 38"E Length: 2.08'
North: 5377.3478' East: 4355.4204'

Segment #2 : Line

Course: N84° 28' 35"E Length: 12.05'
North: 5378.5077' East: 4367.4144'

Segment #3 : Line

Course: S49° 42' 24"E Length: 61.14'
North: 5338.9684' East: 4414.0486'

Segment #4 : Line

Course: S36° 21' 15"W Length: 10.02'
North: 5330.8986' East: 4408.1090'

Segment #5 : Line

Course: N49° 42' 24"W Length: 71.80'
North: 5377.3317' East: 4353.3440'

Perimeter: 157.10' Area: 663.61 Sq. Ft.
Error Closure: 0.0036 Course: S78° 25' 48"E
Error North: -0.00072 East: 0.00354

Precision 1: 43636.11

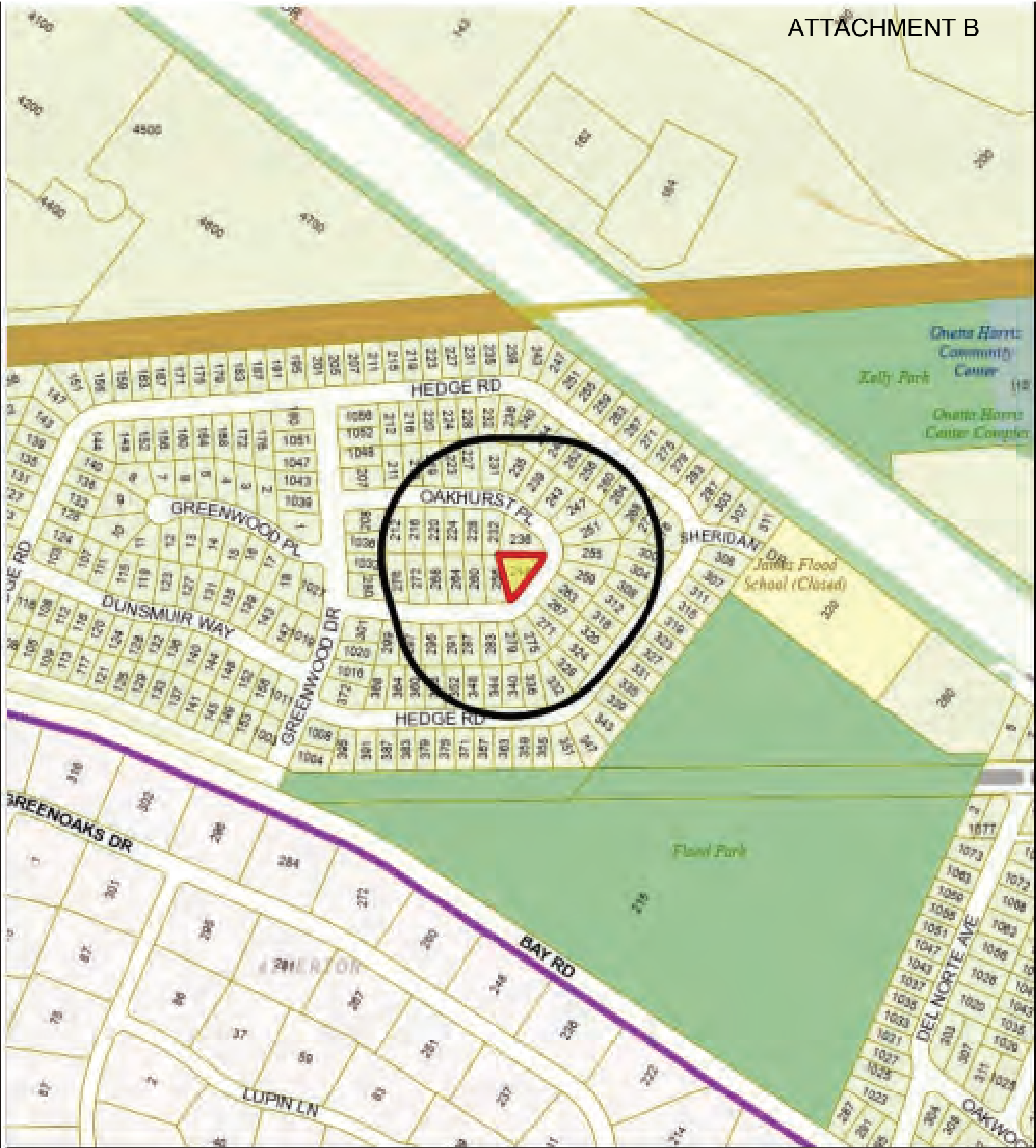

City of Menlo Park
Location Map
248 Oakhurst Lane



OWNERS CERTIFICATE.

We hereby certify that we are the owners of, or have some right, title or interest in and to the real property included within the subdivision shown upon this map, and that we are the only persons whose consent is necessary to pass a clear title to said property, and we consent to the making of said map and subdivision as shown within the colored border lines and hereby dedicate to public use all the roads, ways, drives and places shown upon said map within said subdivision.

We also hereby dedicate for public use easements for public utilities under, on or over those certain strips of land lying between the rear lines and or side lines of lots and the lines designated as "public utilities easements line" as shown on said map, within said subdivisions, such strips of land to be kept open and free from buildings and structures of any kind.

H. J. Dunlap and Jessie Earle Dunlap
H. J. Dunlap and Jessie Earle Dunlap
(as Owners)
THE HIBERNIA SAVINGS AND LOAN SOCIETY
a Banking Corporation, as Mortgagee,
by Joseph P. O'Leary Vice President J.P.
E. R. Tobin Secretary Pro Tem

CERTIFICATE OF CLERK OF BOARD OF SUPERVISORS.

I, W. H. Augustus Clerk of the Board of Supervisors of San Mateo County, State of California, hereby certify that said Board approved the within map on the 26 day of June, 1946, and accepted on behalf of the public, all parcels of land offered for dedication for public use, in conformity with the terms of the offer of dedication.

By W. H. Augustus
County Clerk and Ex-Officio Clerk of
the Board of Supervisors of the County
of San Mateo, State of California.
By A. M. Pullivant
Deputy

CERTIFICATE OF COUNTY RECORDER.

File No. 152816
Filed for record at the request of
PENINSULA TITLE GUARANTY COMPANY
this 17th day of JULY, 1946
at 25 minutes past 2 P.M. in
Volume 25 of MAPS at page 66-51-67-68-70
Records of San Mateo County, California
By A. M. Pullivant
County Recorder
By _____ Deputy
Fee \$ _____

STATE OF CALIFORNIA }
COUNTY OF SAN MATEO }

On this 3 day of JUNE, 1946, before me BERT MAE ARCHER
a Notary Public in and for said County of San Mateo,
State of California, residing therein, duly commissioned
and sworn, personally appeared H. J. Dunlap and
Jessie Earle Dunlap, his wife, known to me to be
the persons whose names are subscribed to the
within instrument and acknowledged to me that they
executed the same.

IN WITNESS WHEREOF, I have hereunto set my hand
and affixed my official seal the day and year in this
certificate first, above written.

Bert Mae Archer
Notary Public in and for the
County of San Mateo, State of California.

My Commission expires APRIL 10, 1950

STATE OF CALIFORNIA }
CITY AND COUNTY }
OF SAN FRANCISCO }

On this 5 day of JUNE, 1946, before me May H. Farrell
a Notary Public in and for the City and County of San Francisco
State of California, residing therein, duly commissioned
and sworn, personally appeared Joseph O. Tobin
known to me to be the Vice President

C. R. Tobin known to me to be the
Secretary Pro Tem of the HIBERNIA SAVINGS AND
LOAN SOCIETY, the banking corporation that executed the
within instrument and known to me to be the persons
who executed the same upon behalf of the corporation
named therein, and acknowledged to me that such
corporation executed the same.

IN WITNESS WHEREOF, I have hereunto set my
hand and affixed my official seal the day and year
in this certificate first above written.

May H. Farrell
Notary Public in and for the City and County
of San Francisco, State of California.

My Commission expires May 11, 1950

BASIS OF BEARING NOTE:

The bearing of Bayshore Highway as shown on
map Dist IV - S.M.-68-D (sheet 20 of 10 sheets) filed
June 8, 1931, Division of Highways, Sacramento, Calif.
All distances and dimensions are shown in Feet and
decimals thereof.
The blue border indicates the boundaries of the land
subdivided by this map.

SURVEYOR'S CERTIFICATE.

I, Paul H. Hardy, hereby certify that I am a
Licensed Land Surveyor, that this map consisting
of five sheets correctly represents a survey made under
my supervision during April and May, 1946; that the
survey is true and complete as shown; that
all monuments, of the kinds shown hereon, actually
exist and that their positions are correctly shown, and
that said monuments are sufficient to enable the
survey to be retraced.

Paul H. Hardy
Licensed Land Surveyor of
State of California
License No 2296

Date June 4, 1946

CERTIFICATE OF APPROVAL BY COUNTY ENGINEER.

I, Melville A. Grant, County Engineer of San Mateo
County, hereby certify that I have examined this
Map; that the subdivision as shown hereon is substantially
the same as it appeared on the tentative
Map; and any approved alterations thereof as approved
by the San Mateo County Planning Commission on
March 15, 1946; that all the provisions of the California
"Subdivision Map Act"; as amended and of San
Mateo County Ordinance No 595, applicable at the time
of the approval of said tentative map, have been complied
with, and this map is technically correct.

Mel Grant June 3rd 1946
County Engineer, San Mateo County, California.

TRACT No. 560
SUBURBAN PARK
SUBDIVISION OF A PORTION OF THE
PROPERTY CONVEYED FROM K. GINESTE
& MARCELLA GINESTE - HIS WIFE &
LAWRENCE H. WALKER & RUTH V. WALKER
HIS WIFE TO H-J-DUNLAP & JESSIE EARLE
DUNLAP - HIS WIFE AS JOINT TENANTS
BY DEED DATED MARCH 28, 1946
RECORDED APRIL 1, 1946 - FILE No. 96090 F

IN UNINCORPORATED TERRITORY IN
THE COUNTY OF SAN MATEO, CALIFORNIA

JAMES & WATERS - CIVIL ENGINEERS
PALO ALTO - BURLINGAME - SAN JOSE - CALIFORNIA
SCALE: 1" = 50' FT. 1946

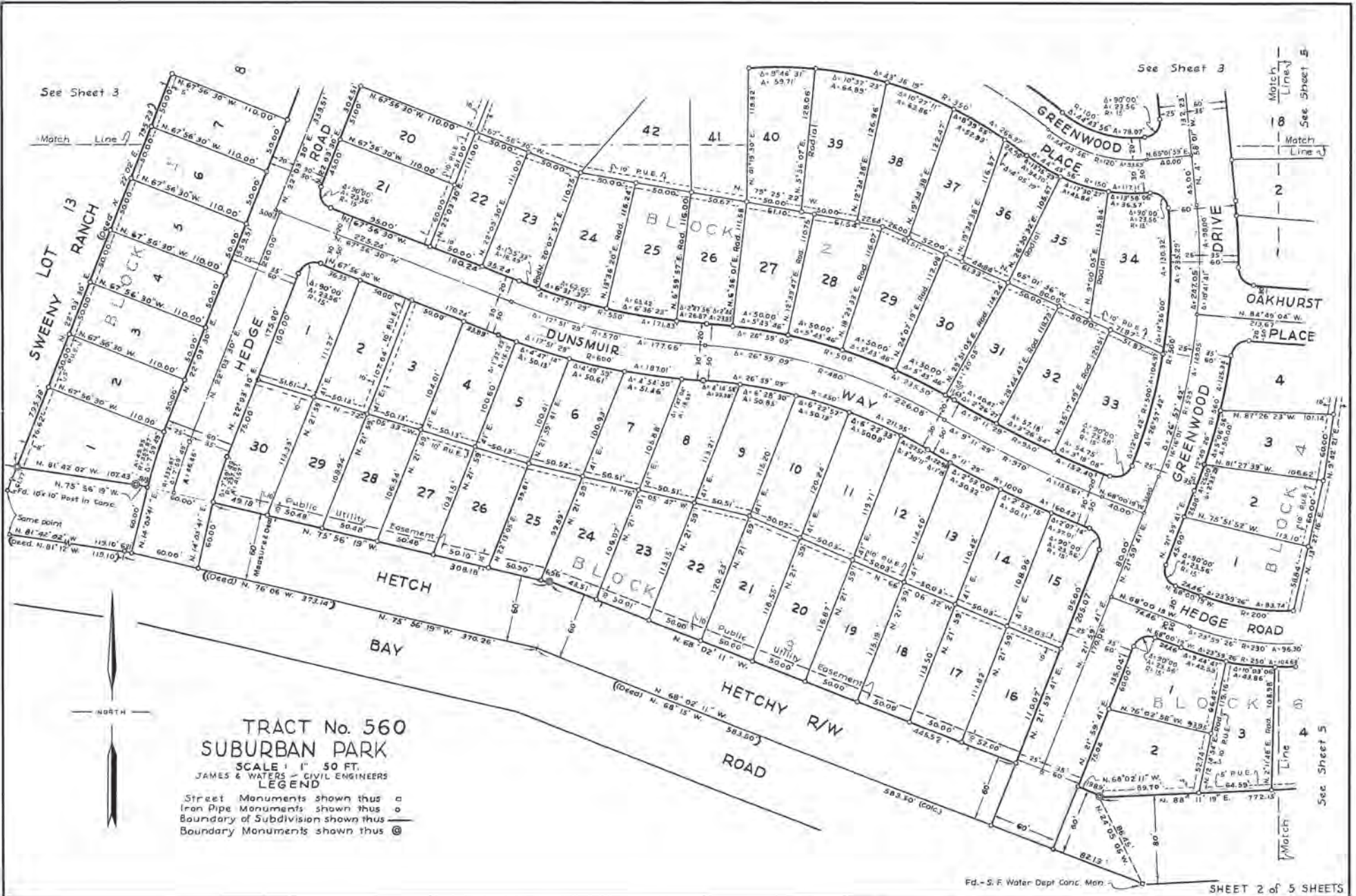

TRACT No. 560
 SUBURBAN PARK
 SCALE 1" = 50 FT.
 JAMES & WATERS - CIVIL ENGINEERS
 LEGEND

Street Monuments shown thus \square
 Iron Pipe Monuments shown thus \circ
 Boundary of Subdivision shown thus ---
 Boundary Monuments shown thus \otimes

TRACT No. 560 SUBURBAN PARK

SCALE: 1" = 50 FT.
JAMES & WATERS - CIVIL ENGINEERS

LEGEND
Boundary Monuments shown thus
Street Monuments shown thus
Iron Pipe Monuments shown thus
Boundary of Subdivision shown thus

S - P - CO. R/W

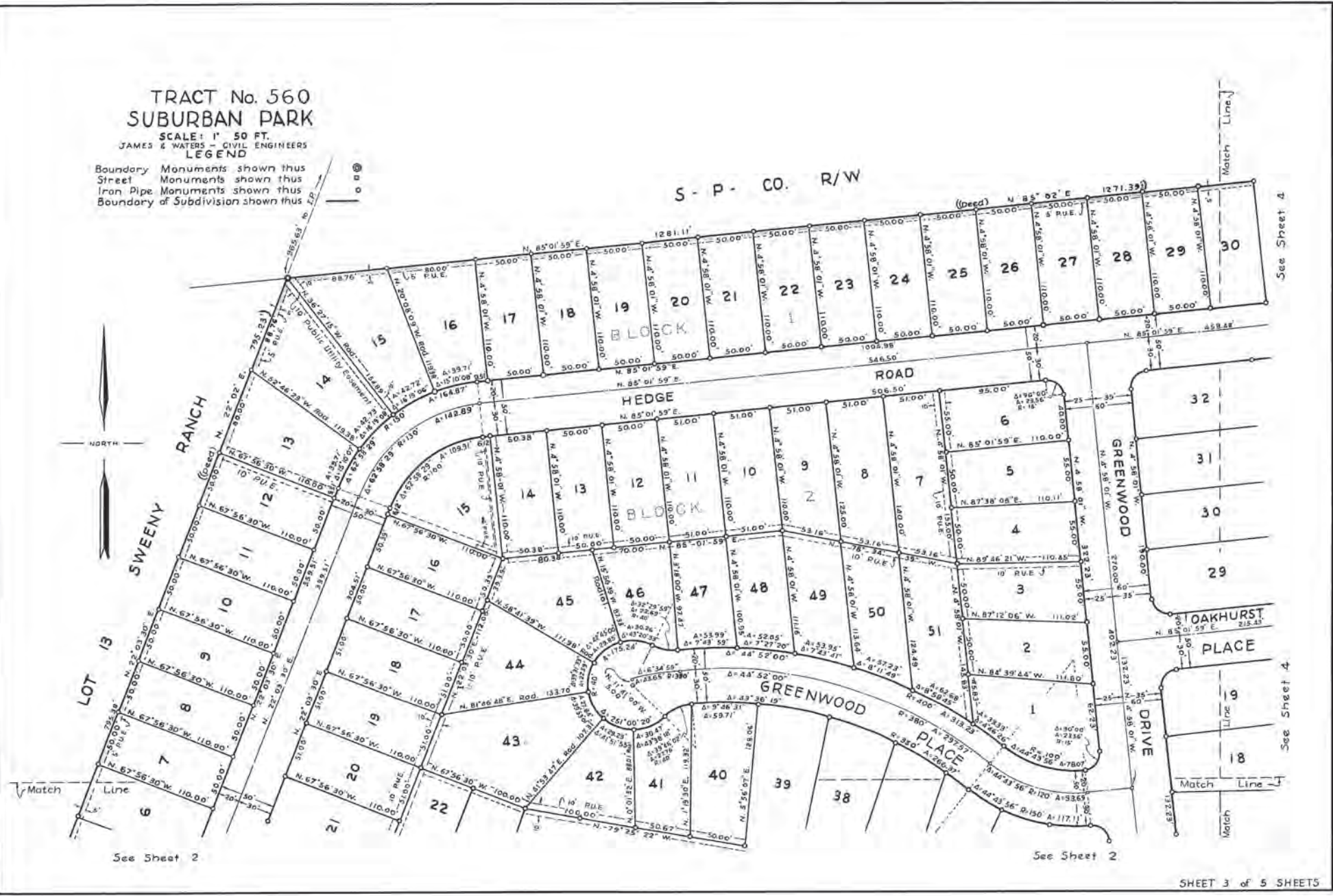

See Sheet 2





See Sheet 2

See Sheet 4

See Sheet 4

TRACT No. 560
SUBURBAN PARK

SCALE: 1" = 50 FT.
JAMES & WATERS - CIVIL ENGINEERS

LEGEND
Boundary Monuments shown thus 
Street Monuments shown thus 
Iron Pipe Monuments shown thus 
Boundary of Subdivision shown thus 

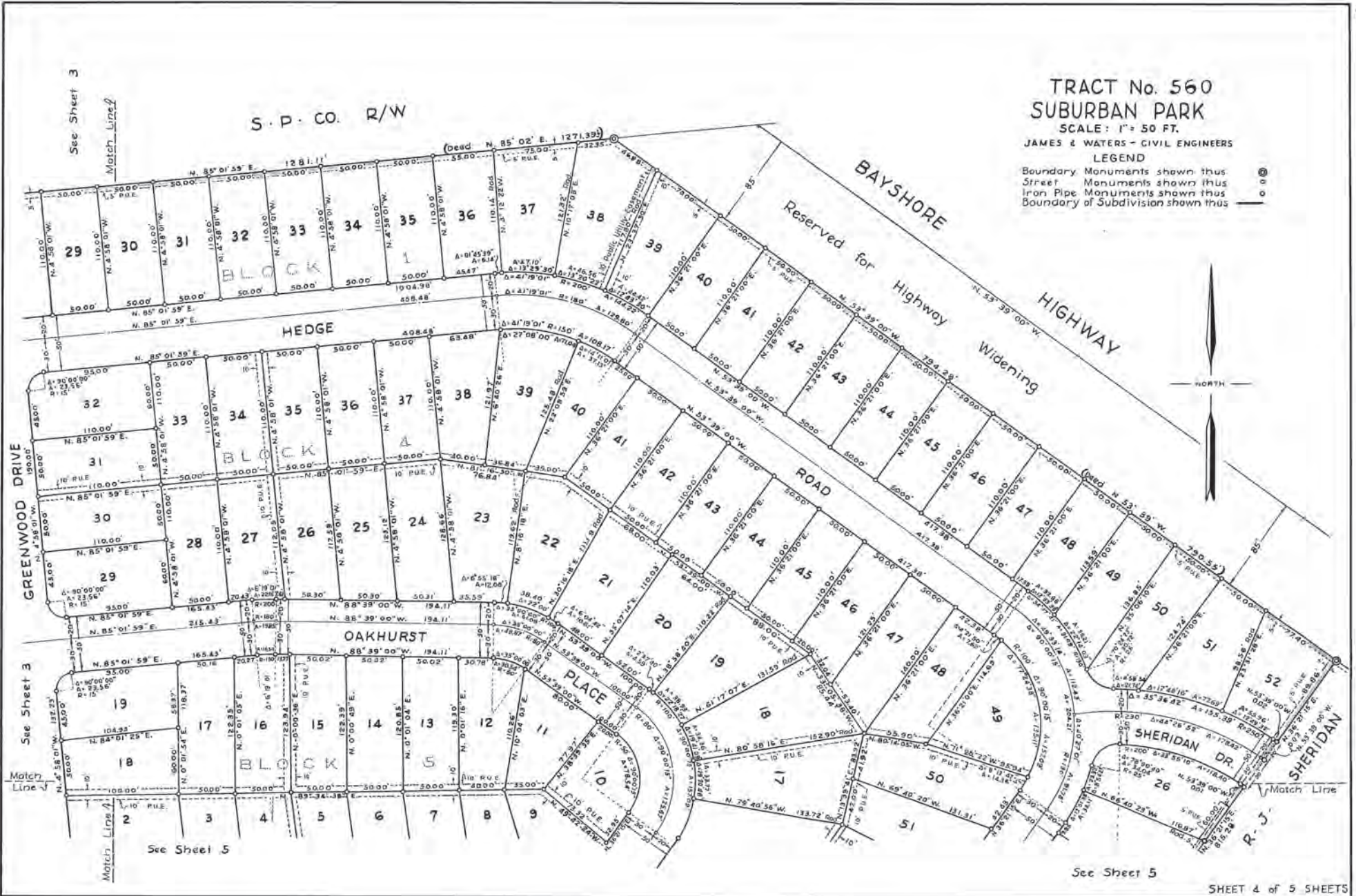

See Sheet 3

Match Line

S. P. CO. R/W

GREENWOOD DRIVE

HEDGE

BAYSHORE

Reserved for Highway Widening

HIGHWAY

ROAD

OAKHURST PLACE

SHERIDAN DR.

See Sheet 3

Match Line

See Sheet 5

See Sheet 5

SHEET 4 of 5 SHEETS

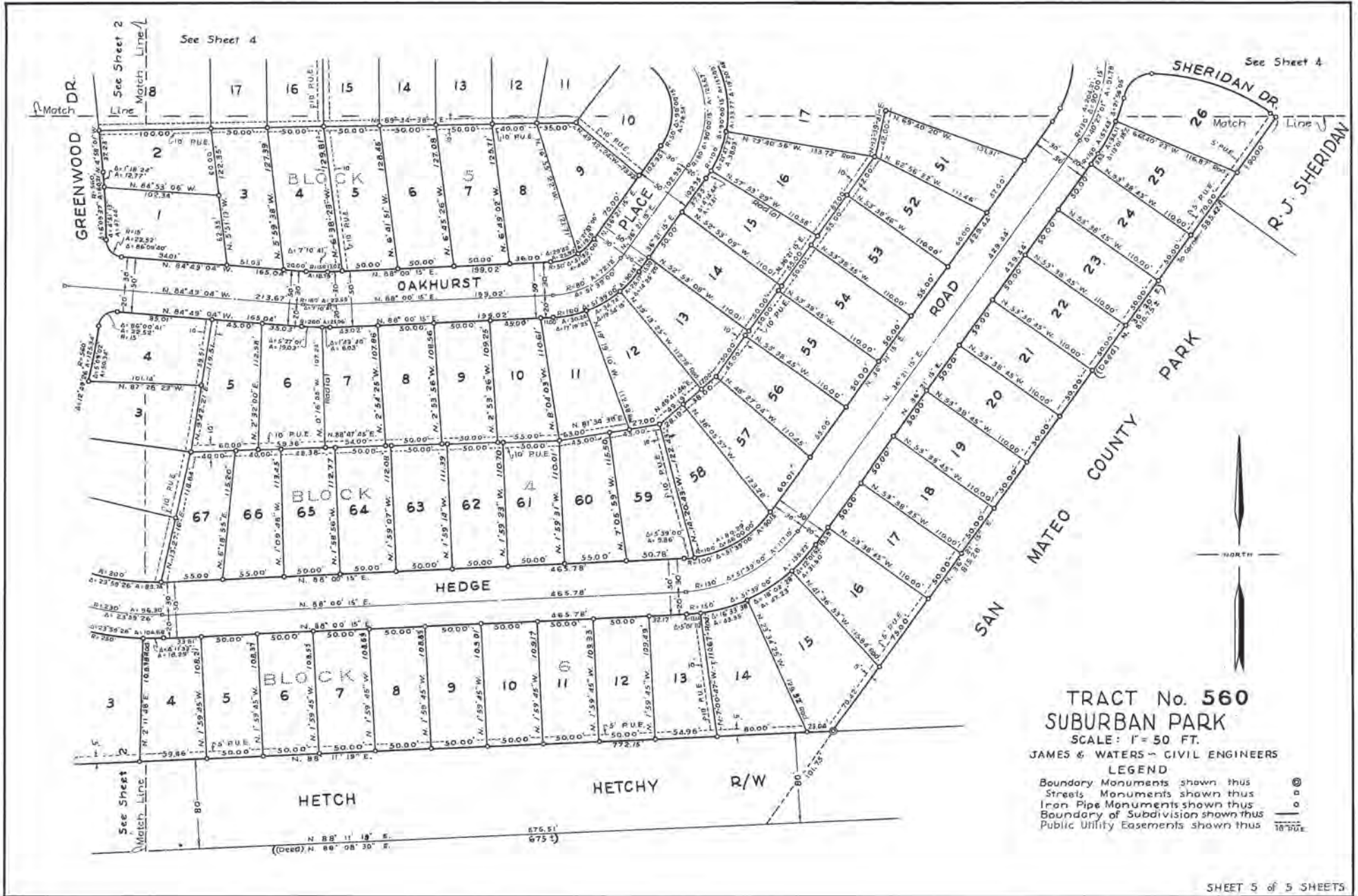

TRACT No. 560
SUBURBAN PARK
 SCALE: 1" = 50 FT.
 JAMES & WATERS - CIVIL ENGINEERS
 LEGEND
 Boundary Monuments shown thus 
 Streets Monuments shown thus 
 Iron Pipe Monuments shown thus 
 Boundary of Subdivision shown thus 
 Public Utility Easements shown thus 

PLANNING COMMISSION RESOLUTION NO. 2022-13**A RESOLUTION OF THE PLANNING COMMISSION OF THE CITY OF MENLO PARK DETERMINING THAT THE ABANDONMENT OF A PUBLIC UTILITY EASEMENT RUNNING OVER A PORTION OF THE EXISTING STRUCTURE AT 248 OAKHURST PLACE IS CONSISTENT WITH THE GENERAL PLAN AND RECOMENDING THAT THE CITY COUNCIL APPROVE THE REQUESTED ABANDONMENT**

WHEREAS, the City of Menlo Park (“City”) received an application for the vacation of a 10-foot-wide Public Utility Easement (PUE) running through a portion of an existing residence (“the Project”) in connection with an application to construct a second-floor addition and perform interior and exterior modifications to the existing nonconforming, single-story, single-family residence in the R-1-U (Single Family Urban Residential) zoning district; and

WHEREAS, the plans show a 10-foot-wide Public Utility Easement (PUE) running through a portion of the existing structure that has no utilities and has never been used; and

WHEREAS, Subsection (a) of Section 8333 of the California Streets and Highways Code allows a summary vacation of an easement that has not been used for the purpose for which it was dedicated or acquired for five consecutive years immediately preceding the proposed vacation; and

WHEREAS, the Planning Commission of the City of Menlo Park has considered the requested abandonment of a public utility easement within the property at 248 Oakhurst Place shown on Exhibit A, which is attached and made apart hereto; and

WHEREAS, the Planning Commission reviewed the proposed public utility easement abandonment request and determined that the request complies with the General Plan goals, policies, and programs in that the easement to be vacated is not necessary for public use and there have been no objections provided to the proposed abandonment by utility companies; and

WHEREAS, the Project, requires discretionary actions by the City as summarized above, and therefore the California Environmental Quality Act (“CEQA”) Public Resources Code Section §21000 et seq.) and CEQA Guidelines (Cal. Code of Regulations, Title 14, §15000 et seq.) require analysis and a determination regarding the Project’s environmental impacts; and

WHEREAS, the City is the lead agency, as defined by CEQA and the CEQA Guidelines, and is therefore responsible for the preparation, consideration, certification, and approval of environmental documents for the Project; and

WHEREAS, the Project is categorically except from environmental review pursuant to Cal. Code of Regulations, Title 14, §15305 et seq. (Minor Alternation in Land Use Limitations); and

WHEREAS, all required public notices and public hearings were duly given and held according to law; and

WHEREAS, at a duly and properly noticed public hearing held on July 25, 2022, the Planning Commission fully reviewed, considered, and evaluated the whole of the record including all public and written comments, pertinent information, documents and plans, prior to taking action regarding the Project.

NOW, THEREFORE, THE MENLO PARK PLANNING COMMISSION HEREBY RESOLVES AS FOLLOWS:

1. The Project is categorically except from environmental review pursuant to Cal. Code of Regulations, Title 14, §15305 et seq. (Minor Alternation in Land Use Limitations).
2. The Planning Commission hereby finds that the public utility easement abandonment would be compatible with orderly development, because the easement to be vacated has never been used, is not necessary for public use, and there have been no objections to the abandonment proposal.
3. The Planning Commission hereby finds that the proposed public utility easement vacation within 248 Oakhurst Lane shown in Exhibit A is consistent with the General Plan and recommends that the City Council approved the requested abandonment as proposed.

I, Corinna Sandmeier, Acting Principal Planner and Planning Commission Liaison of the City of Menlo Park, do hereby certify that the above and foregoing Planning Commission Resolution was duly and regularly passed and adopted at a meeting by said Planning Commission on July 25, 2022, by the following votes:

AYES: Barnes, DeCardy, Do, Harris, Riggs, Thomas

NOES: None

ABSENT: Tate

ABSTAIN: None

IN WITNESS THEREOF, I have hereunto set my hand and affixed the Official Seal of said City on this 25th day of July, 2022.

DocuSigned by:

 2C12F0CE92BC45A...

Corinna Sandmeier
Acting Principal Planner and Planning Commission Liaison
City of Menlo Park

Exhibits

- A. Legal Description and Plat Map
- B. Plan Sheet

EXHIBIT "A"
LEGAL DESCRIPTION FOR
PUBLIC UTILITY EASEMENT VACATION
248 OAKHURST PLACE, MENLO PARK, CALIFORNIA

All that certain real property, situate in the City of Menlo Park, County of San Mateo, State of California, being part of the land of Loewke as described in that certain Grant Deed recorded May 8, 2020 as Instrument No. 2020-041334, Official Records of San Mateo County, and being a portion of Lots 9 and 10, Block 5 as shown on "Tract No. 560 Suburban Park", filed for record on July 17, 1946 in Book 25 of Maps at Pages 66 through 70, Records of San Mateo County, as shown on Exhibit "B" made a part hereof, more particularly described as follows:

Commencing at the most Westerly corner of said Lands, said point being the West corner of said Lot 9; thence along the westerly line of said Lands South 16°55'22" East, 5.21 feet; thence leaving said line North 89°34'38" East, 31.66 feet to the **Point of Beginning**; thence North 89°34'38" East, 2.08 feet and North 84°28'35" East, 12.05 feet; thence South 49°42'24" East, 61.14 feet to a point on the northwesterly right of way of Oakhurst Place, 50 feet wide, as shown on said Map; thence along said right of way South 36°21'15" West, 10.02 feet; thence leaving said line North 49°42'24" West, 71.80 feet to the **Point of Beginning**.

Containing 664 square feet, more or less.

END OF DESCRIPTION



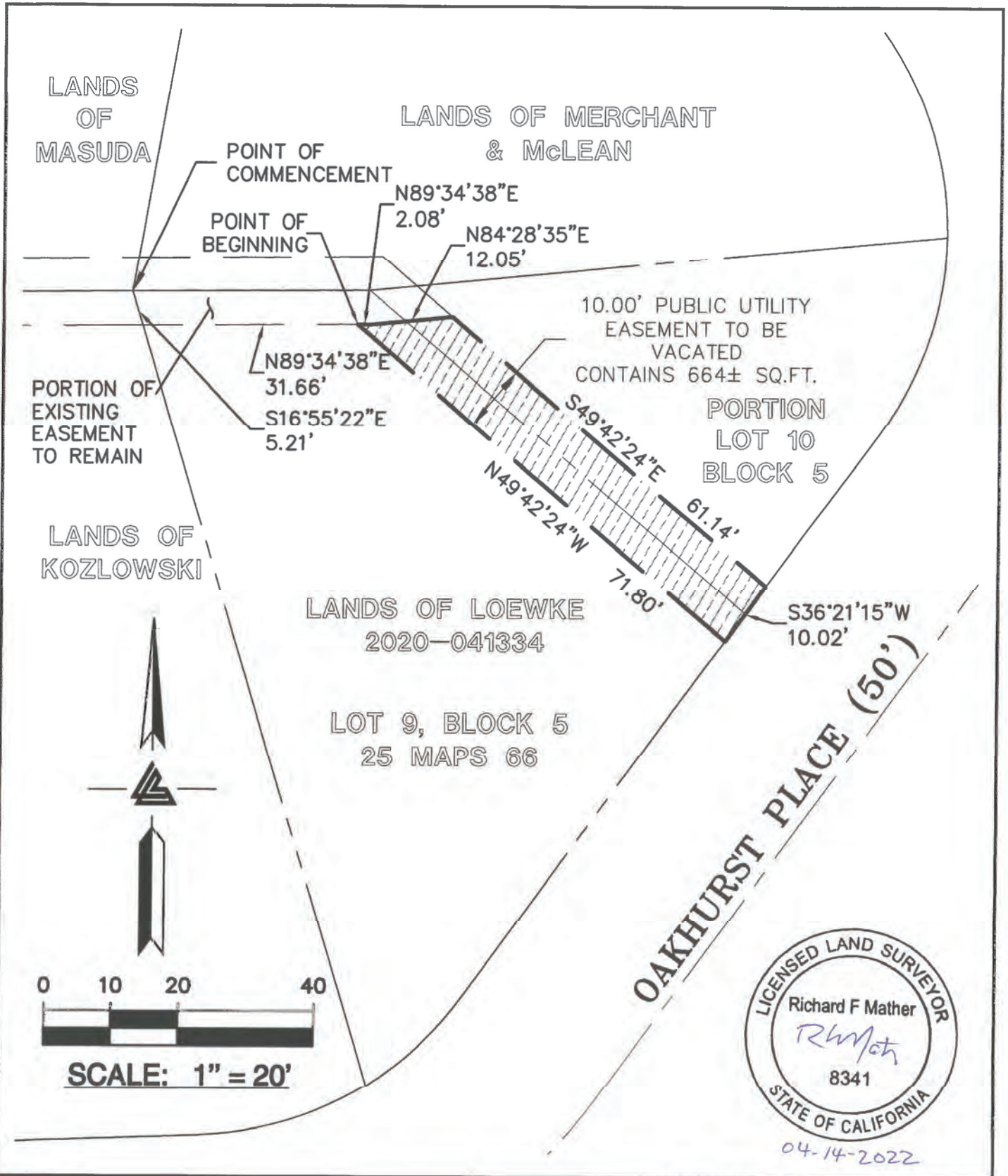

04-14-2022



LEA & BRAZE ENGINEERING, INC.

CIVIL ENGINEERS • LAND SURVEYORS

BAY AREA REGION
 2495 INDUSTRIAL PKWY WEST
 HAYWARD, CALIFORNIA 94545
 (P) (510) 887-4086
 (F) (510) 887-3019

SACRAMENTO REGION
 3017 DOUGLAS BLVD, # 300
 ROSEVILLE, CA 95661
 (P) (916)966-1338
 (F) (916)797-7363

WWW.LEABRAZE.COM

EXHIBIT 'B'
PLAT TO ACCOMPANY LEGAL
DESCRIPTION FOR PUBLIC UTILITY
EASEMENT VACATION
248 OAKHURST PLACE MENLO
PARK, CA

JOB NO 2200508

SCALE: 1" = 20'

North: 5377.3324' East: 4353.3404'

Segment #1 : Line

Course: N89° 34' 38"E Length: 2.08'

North: 5377.3478' East: 4355.4204'

Segment #2 : Line

Course: N84° 28' 35"E Length: 12.05'

North: 5378.5077' East: 4367.4144'

Segment #3 : Line

Course: S49° 42' 24"E Length: 61.14'

North: 5338.9684' East: 4414.0486'

Segment #4 : Line

Course: S36° 21' 15"W Length: 10.02'

North: 5330.8986' East: 4408.1090'

Segment #5 : Line

Course: N49° 42' 24"W Length: 71.80'

North: 5377.3317' East: 4353.3440'

Perimeter: 157.10' Area: 663.61 Sq. Ft.

Error Closure: 0.0036 Course: S78° 25' 48"E

Error North: -0.00072 East: 0.00354

Precision 1: 43636.11



STAFF REPORT

City Council

Meeting Date:

9/13/2022

Staff Report Number:

22-174-CC

Regular Business:

Provide direction on preferred Middle Avenue conceptual design and adopt a resolution to install no parking zones on Middle Avenue, install an all-way stop at Middle Avenue and San Mateo Drive, and authorize a temporary closure of Blake Street at Middle Avenue

Recommendation

Staff recommends the City Council provide direction on the Middle Avenue complete street project conceptual designs and next steps as outlined in Table 2, for the following major elements:

- Bicycle facility improvements/ parking removal
- Corridor traffic calming treatments
- Intersection improvements
- Blake Street temporary closure
- Sidewalk gap closure

Additionally, staff recommends the City Council adopt a resolution (Attachment A) to install no parking zones on Middle Avenue entirely on one side and at select locations on the other side (Exhibit A of Attachment A), install an all-way stop at Middle Avenue and San Mateo Drive, and authorize a temporary closure of Blake Street at Middle Avenue using temporary materials.

Policy Issues

This project is consistent with policies and programs stated in the 2016 General Plan Circulation Element (e.g., CIRC-1.7, CIRC-1.8, CIRC-2.7, etc.) These policies seek to maintain a safe, efficient, attractive, user-friendly circulation system that promotes a healthy, safe and active community and quality of life throughout Menlo Park.

This project is a 2021 City Council priority and continued into 2022.

Design and implementation of bicycle facilities on Middle Avenue between El Camino Real and University Drive fulfill "Mitigation Measure TRA-2.1" of the Mitigation Monitoring and Reporting Program (MMRP) established in the 500 El Camino Real (i.e., Middle Plaza) Project final environmental impact report (FEIR) approved in 2017.

Background

Middle Avenue is an important part of the Menlo Park transportation network, fronting Safeway Plaza, Nealon and Lyle Parks, senior centers, preschools and a church. The street is used by people walking, bicycling, and driving for both local and through trips. Children on bicycles use Middle Avenue as a route to

Hillview Middle School and Oak Knoll Elementary School. Others use it to access the bicycle bridge at the south end of San Mateo Drive to reach Stanford University.

Middle Avenue is currently a Class III bicycle route (i.e., bicycles and vehicles share space) due to on-street parking on both sides. Removal of parking on one or both sides of the street is required to establish Class II bicycle lanes (i.e., bicycles and vehicles have dedicated space.)

Based on results of a 2020 citywide speed survey, as well as the anticipated opening of Middle Plaza, the City Council directed staff to conduct a complete street study for Middle Avenue with the following objectives:

- Enhance bicyclist and pedestrian visibility and improve safety of all street users
- Provide safe and comfortable cycling and pedestrian infrastructure and encourage sustainable mode of transportation
- Increase accessibility of the corridor by supporting improvements related to Middle Plaza and ongoing study of the grade-separated pedestrian and bicycle crossing

On August 23, the City Council received an informational update on the Middle Avenue Complete streets project. This update identified the outreach and analysis conducted to date and summarized the Complete Streets Commission (Commission) recommendation for next steps on the project. Attachment B provides a hyperlink to the staff report for this meeting.

Outreach conducted for the project included in-person and virtual public meetings, as well as Commission meetings. More than 600 individuals participated in the outreach process for this project. A comprehensive record of the outreach, including surveys, public outreach comments, and email messages is provided in that report. Since that time, two City Councilmembers also hosted a community meeting Saturday, September 2 to review the project elements and one City Councilmember held an online informational session with nearby residents.

Analysis

In conjunction with community and Commission feedback, staff is recommending the preferred conceptual design options for the Middle Avenue complete street project in Table 2, as categorized below:

- Bicycle facility improvements
- Corridor traffic calming treatments
- Intersection improvements
- Blake Street temporary closure
- Sidewalk gap closure

The design and implementation of approved bicycle facilities on Middle Avenue between El Camino Real and University Drive will be fulfilled by Stanford as part of the Middle Plaza MMRP. As a result, exhibits of the corridor are generally split by implementing party (i.e., Stanford and the City.) For simplicity, the intersection design options are shown as a separate exhibit as these options could be paired with multiple bicycle facility options.

Bicycle facility improvements

Three options were developed, including the option of reconfiguring the Nealon Park frontage parking spaces for other uses, (Attachment C):

- Option 1 (entire corridor): Class II bicycle lanes with a two-foot buffer on each side (all dimensions are

- approximate.) Parking would be removed on one side.
- Option 2 (entire corridor): Class II bicycle lanes with a four-foot buffer on each side. Parking would be removed on both sides.
- Option 3: El Camino Real to University Drive only (could be paired with either Option 1 or 2 between University Drive and Olive Street)
 - North side: two-way Class IV separated bikeway or Class II buffered bicycle lane
 - South side: preserve parking or provide Class II bicycle lane (without a buffer)

All design options would reduce the travel lanes to 10-feet and provide at least five-foot wide bicycle lanes.

Corridor traffic calming treatments

Table 1 summarizes the locations and recommended measures with the objective of providing lower vehicular speeds and safer crossing opportunities (see Attachment C for illustration.)

| Table 1: Proposed traffic calming measures | | |
|--|--|--|
| Locations | Issues/challenges | Potential traffic calming measures |
| Blake Street | Located across from Nealon Park, high volume of pedestrians and bicyclists crossing street at Blake Street | <ul style="list-style-type: none"> • Raised crosswalk • Flashing beacons* |
| Arbor Road | Located across from Lyle Park, church, and preschool | <ul style="list-style-type: none"> • Raised crosswalk • Flashing beacons |
| San Mateo Drive | Road alignment not feasible for roundabout | <ul style="list-style-type: none"> • All-way stop signs • Bulb-out/Curb extension on Middle Avenue |
| Olive Street | T-intersection not feasible for roundabout | <ul style="list-style-type: none"> • Bulb-out/Curb extension on Middle Avenue |
| Cotton Street | Potential cut-through route | <ul style="list-style-type: none"> • Raised crosswalk |
| Locations TBD | Speeding, education | <ul style="list-style-type: none"> • Speed feedback signs (2 each direction) • Speed hump (1) |

* A rectangular rapid flashing beacon was recently installed at this location as part of the Nealon Park sidewalk project

Intersection improvements

Staff evaluated potential intersection improvements at three locations:

- El Camino Real – staff explored intersection improvements to provide dedicated space and signal improvements to better separate bicyclists and pedestrians from vehicular traffic, as well as potential driveway changes at nearby properties that might improve safety
- University Drive – staff explored removing a right turn pocket in the westbound direction to reduce intersection complexity and a potential trial of a mini-roundabout using temporary materials
- Olive Street – staff explored removing a right turn pocket in the westbound direction to reduce intersection complexity

Blake Street closure

Staff met with Blake Street residents and discussed potential trial phase options to implement a temporary Blake Street closure. Generally, residents supported closing vehicular access to Middle Avenue while maintaining access to College Avenue. Any temporary closure would be designed to permit access by emergency vehicles, pedestrians, and bicyclists.

Sidewalk gap closure

Construction of a sidewalk on the south side of the street could take place within the City right-of-way, but

would require removal of a number of street trees, including some heritage trees, as well as landscape features and irrigation in front of numerous residences. Based on the construction cost of a recent sidewalk project, staff estimated that approximately \$4 million would be needed to complete approximately 3,000 feet of missing concrete sidewalk.

Recommendations

Table 2 summarizes Commission recommendations from the July 13 meeting, and details recommended by staff to be incorporated into engineering design and next steps.

| Table 2: Project recommendations | | |
|---|--|--|
| Elements | Commission recommendation | Design details/next steps |
| Bicycle facility/ parking removal | <ul style="list-style-type: none"> Supported new bicycle lanes and preferred parking removal on one side Suggested incorporating bus stops and shared pedestrian/ bicycle space into final design | <ul style="list-style-type: none"> Class II bicycle lanes with small (approximately 2' buffer) and 5 to 6' bicycle lanes <ul style="list-style-type: none"> Parking removal El Camino Real to University Drive – remove from north side of the street, <ul style="list-style-type: none"> Nealon Park – reconfigure frontage to parallel parking spaces University Drive to Olive Street – remove from south side |
| | <ul style="list-style-type: none"> Request that staff explore options for additional parking removal where feasible. Deferred final parking retention decision to staff | <ul style="list-style-type: none"> Additional parking removal near raised crossings and intersections and in front of Lyle Park and the New Community Church* |
| Corridor traffic calming | <ul style="list-style-type: none"> Supported staff recommendations | <ul style="list-style-type: none"> Proceed with next steps for design/ implementation |
| | <ul style="list-style-type: none"> Supported trial closure of Blake Street | <ul style="list-style-type: none"> Continue to work with residents to design/ implement trial closure at Blake Street <ul style="list-style-type: none"> Explore as part of design process |
| El Camino Real Intersection | <ul style="list-style-type: none"> Supported dedicated intersection (Attachment D) | <ul style="list-style-type: none"> Initiate dialogue with Safeway and Shell gas station property owners on right of way impacts based on design |
| | <ul style="list-style-type: none"> Supported a leading pedestrian interval as a short term improvement Supported evaluation of no right turn on red on eastbound and protected left turn phases on Middle Avenue as long term improvements | <ul style="list-style-type: none"> Proceed with short and long term improvements per Commission recommendations |
| Safeway and Shell gas station driveways | <ul style="list-style-type: none"> Supported ongoing monitoring of conditions at the Safeway driveway but no changes Supported Shell gas station driveway closure | <ul style="list-style-type: none"> Initiate dialogue with Shell gas station property owner on driveway operation |
| University Drive intersection | <ul style="list-style-type: none"> Supported right turn removal for bulbouts Supported pilot of a mini-roundabout and potential permanent installation pending outcome of the pilot (Attachment E) | <ul style="list-style-type: none"> Develop design for pilot mini-roundabout as part of the design process <ul style="list-style-type: none"> Implementation would require substantial staff resources to install, monitor, and evaluate the pilot Depending on staffing levels at that time, it may become necessary to defer the pilot or put another discretionary transportation project on hold |
| Olive Street intersection | <ul style="list-style-type: none"> Supported right turn removal for bulbouts | <ul style="list-style-type: none"> Proceed with Commission recommendations |
| Sidewalk gaps | <ul style="list-style-type: none"> Supported continuous sidewalk | <ul style="list-style-type: none"> Add project to the 5-year Capital Improvement Program |

* Staff has reviewed and believes that the locations where additional parking removal may be appropriate include near intersections and raised crosswalks in accordance to Section 3B.19 of the California Manual on Uniform Traffic Control Devices (CAMUTCD) to improve sightlines (Attachment F) and near Lyle Park and the New Community Church because of availability of parking in on-site lots and on side streets. Parking removal near Lyle Park and the church will be confirmed through further parking analysis before implementation.

Next Steps

If approved, staff is proposing to implement the project as follows:

- El Camino Real to University Drive: Staff will direct Stanford to design and implement the approved bicycle lane concept and improvements, consistent with the conditions of approval for Middle Plaza. This work is anticipated to start immediately on approval and be completed in the next nine to 12 months.
- University Drive to Olive Street: Staff will solicit design proposals from qualifying consultants to complete design and estimate the cost of improvements (e.g., bicycle lane, traffic calming treatments, signal improvements, mini-roundabout, etc.) Staff may pursue grants and/or return to City Council in a future budget cycle to fund the improvements that exceed the existing capital improvement program allocation. Staff anticipates that the final design will require 12 to 15 months to complete. Parking removal will take place after design is complete, 30 days prior to when installation of the bikeway would begin on Middle Avenue. Other elements of the project, in particular intersection improvements at El Camino Real, are expected to take longer to implement since Caltrans approval of the design and permits are required. The stop sign installation at San Mateo Drive can be implemented in advance of the design of other elements if directed.
- Blake street temporary closure: Staff will take the lead on design, coordination, and installation the temporary closure. Staff anticipates installing the temporary closure within the next six months.
- Private property coordination: staff will initiate dialogue with Safeway and Shell gas station property owners on driveway improvements and right of way needs for intersection improvements at Middle Avenue and El Camino Real.
- Roadway travel pattern / data collection: staff will collect 24-hour daily roadway volumes counts on nearby perpendicular streets (e.g., Arbor Road, San Mateo Drive, Cotton Street) and parallel streets (e.g., College Avenue, Cambridge Avenue, Santa Cruz Avenue), before and after the project implementation, to evaluate travel patterns. These will be conducted as part of the City's regular traffic data collection program.
- Sunday parking occupancy survey: staff will conduct at least one Sunday parking occupancy survey at and near New Community Church during Sunday service. If substantial parking demand is evidenced that exceeds capacity on adjacent streets, staff will reevaluate the additional parking removal proposed in front of Lyle Park and the New Community Church during final design.

Impact on City Resources

Funds for project evaluation and improvement design are identified in the City's Capital Improvement Plan in the amount of \$200,000, as adopted by City Council. Design and construction for improvements along Middle Avenue between El Camino Real and University Drive would be funded by Stanford. Improvements along Middle Avenue between University Drive and Olive Street would require additional funding.

Environmental Review

The Middle Avenue complete street project is categorically exempt under the California Environmental Quality Act Article 19, § 15301 Existing Facilities - Class I since it involves minor construction on a public street. No additional vehicle miles traveled or roadway capacity will be added as a result of implementation of future bicycle lanes and traffic calming measures.

Public Notice

Public notification was achieved by posting the agenda, with the agenda items being listed, at least 72

hours prior to the meeting. Additional public outreach was achieved by sharing meeting information on the project website and sending email to the project interest list.

Attachments

- A. Resolution
- B. Hyperlink – August 23, 2022 City Council staff report:
beta.menlopark.org/files/sharedassets/public/agendas-and-minutes/city-council/2022-meetings/agendas/20220823-city-council-agenda-packet.pdf#page=446
- C. Conceptual bicycle facility design plans and cross-sections
- D. El Camino Real intersection treatments
- E. University Drive intersection treatments
- F. CAMUTCD Figure: 3B-21 (CA)

Report prepared by:

Kevin Chen, Senior Transportation Engineer

Esther Jung, Associate Civil Engineer

Report reviewed by:

Hugh Louch, Assistant Public Works Director – Transportation

RESOLUTION NO. XXXX**RESOLUTION OF THE CITY COUNCIL OF THE CITY OF MENLO PARK
AUTHORIZING THE INSTALLATION OF “NO PARKING” ZONES ON MIDDLE
AVENUE, INSTALLATION OF AN ALL-WAY STOP AT MIDDLE AVENUE AND
SAN MATEO DRIVE, AND TEMPORARY CLOSURE OF BLAKE STREET AT
MIDDLE AVENUE NECESSITATED BY THE MIDDLE AVENUE COMPLETE
STREETS PROJECT**

WHEREAS, on October 10, 2017, the City Council certified the Final Environmental Impact Report and approved the Development Agreement for the Middle Plaza at 500 El Camino Real project, which, as a part of mitigation measures, requires Stanford University to develop, design and implement of Class II or Class III bicycle lanes between El Camino Real and University Drive on Middle Avenue; and,

WHEREAS, on October 13, 2020, the City Council approved the citywide engineering and traffic survey to established recommended speed limits and directed staff to return with traffic calming options on Middle Avenue to achieve a desired speed of 25 miles per hour;

WHEREAS, on March 9, 2021, City Council discussed yearly work plan and priorities and directed staff to develop Middle Avenue complete streets project conceptual design options, for the entire corridor, with the following objectives:

- Enhance bicyclist and pedestrian visibility and improve safety of all street users
- Provide safe and comfortable cycling and pedestrian infrastructure and encourage sustainable mode of transportation
- Increase accessibility of the corridor by supporting improvements related to Middle Plaza and ongoing study of the grade-separated pedestrian and bicycle crossing; and,

WHEREAS, California Vehicle Code Section 21350 authorizes local jurisdictions to install traffic control devices, including stop signs; and

WHEREAS, California Vehicle Code Section 21101 authorizes local jurisdictions to temporarily or permanently close certain streets to vehicular traffic subject to certain conditions; and

WHEREAS, City of Menlo Park Municipal Code Section 11.12.010 allows the City to authorize the installation of any traffic control devices not otherwise prohibited by the California Vehicle Code; and

WHEREAS, the new proposed all-way stop at Middle Avenue and San Mateo Drive would support improved driver yielding to pedestrians crossing Middle Avenue and people bicycling to and from the bicycle bridge at the end of San Mateo Drive that is a common route for people traveling to and from Stanford University and other nearby destinations; and

WHEREAS, in March 2022, staff held in-person and virtual public meetings to inform residents about the project and gather feedback from the community to shape potential bicycle improvements and traffic calming options; and

WHEREAS, nearly 100 people attended the public meetings and 600 people responded to a public survey, providing comments on current issues, needs, and priorities for the corridor; and,

WHEREAS, on July 13, 2022, the Complete Streets Commission recommended to the City Council a preferred conceptual design that includes, among other design elements:

- Establishment of “no parking” zones on one side of Middle Avenue for bicycle lane installation and additional “no parking” zones on the other side of the street where feasible
- Installation of a new all-way stop sign on at Middle Avenue and San Mateo Drive
- Development of a temporary closure of Blake Street at Middle Avenue; and,

WHEREAS, the City of Menlo Park, acting by and through its City Council, having considered and been fully advised in the matter and good cause appearing therefore.

NOW, THEREFORE, BE IT RESOLVED, the City Council of Menlo Park does hereby authorize the establishment of additional “no parking” zones on one side of Middle Avenue and up to twenty-four spaces on the other side of Middle Avenue to address sight line issues, as shown on Exhibit A.

NOW, THEREFORE, BE IT FURTHER RESOLVED, that the City of Council of Menlo Park does hereby authorize the installation of an all-way stop at Middle Avenue and San Mateo Drive.

NOW, THEREFORE, BE IT FURTHER RESOLVED, that the City Council of Menlo Park does hereby authorize the temporary closure of that portion of Blake Street to motor vehicles, while retaining access for emergency vehicles, pedestrians, and bicyclists, more specifically depicted in Exhibit A and using temporary materials to be maintained or removed at the direction of the City Public Works Director or designee.

I, Judi A. Herren, City Clerk of Menlo Park, do hereby certify that the above and foregoing City Council Resolution was duly and regularly passed and adopted at a meeting by said City Council on the thirteenth day of September, 2022, by the following votes:

AYES:

NOES:

ABSENT:

ABSTAIN:

IN WITNESS WHEREOF, I have hereunto set my hand and affixed the Official Seal of said City on this ___ day of September, 2022.



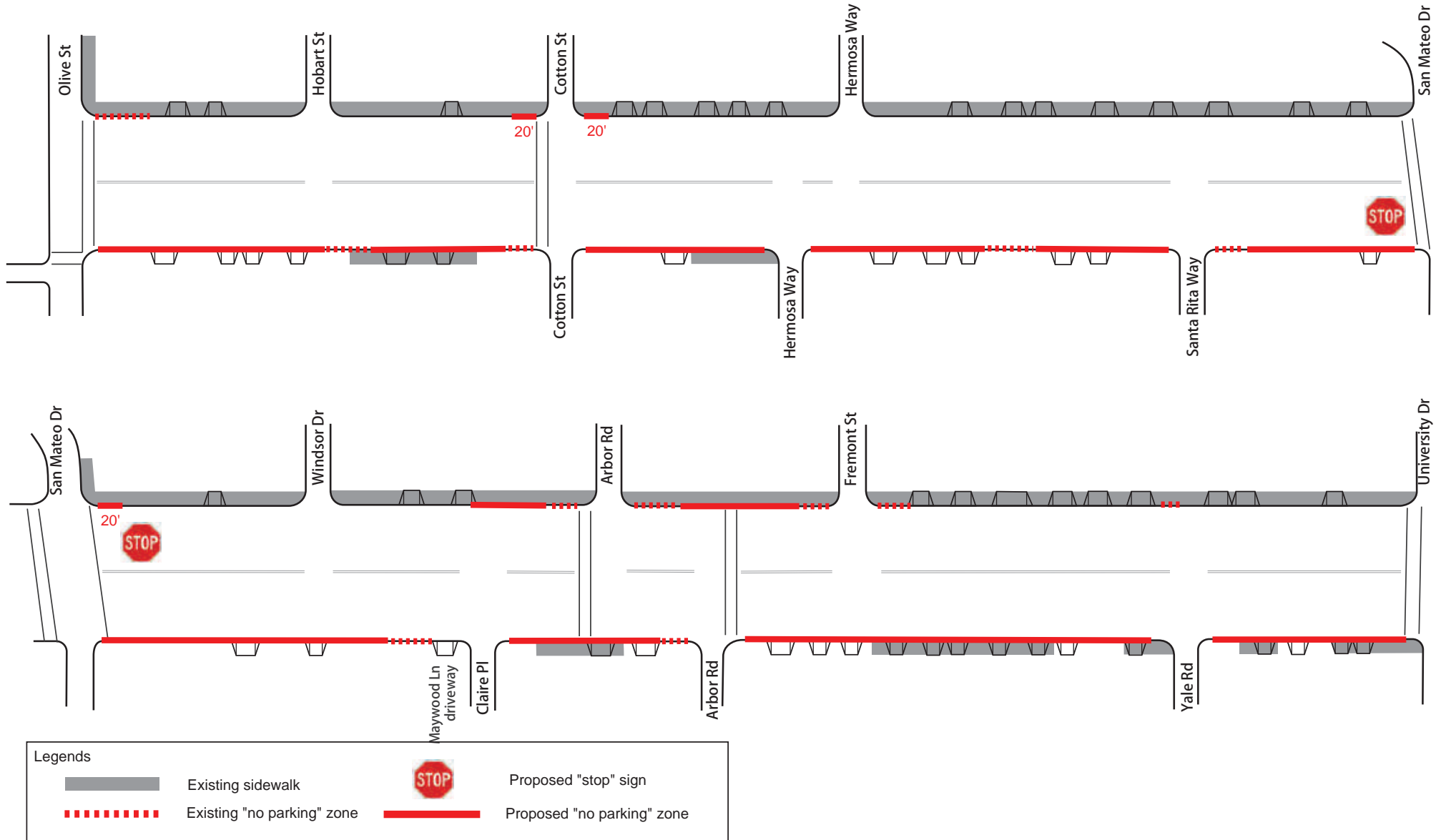

Judi A. Herren, City Clerk

Exhibits

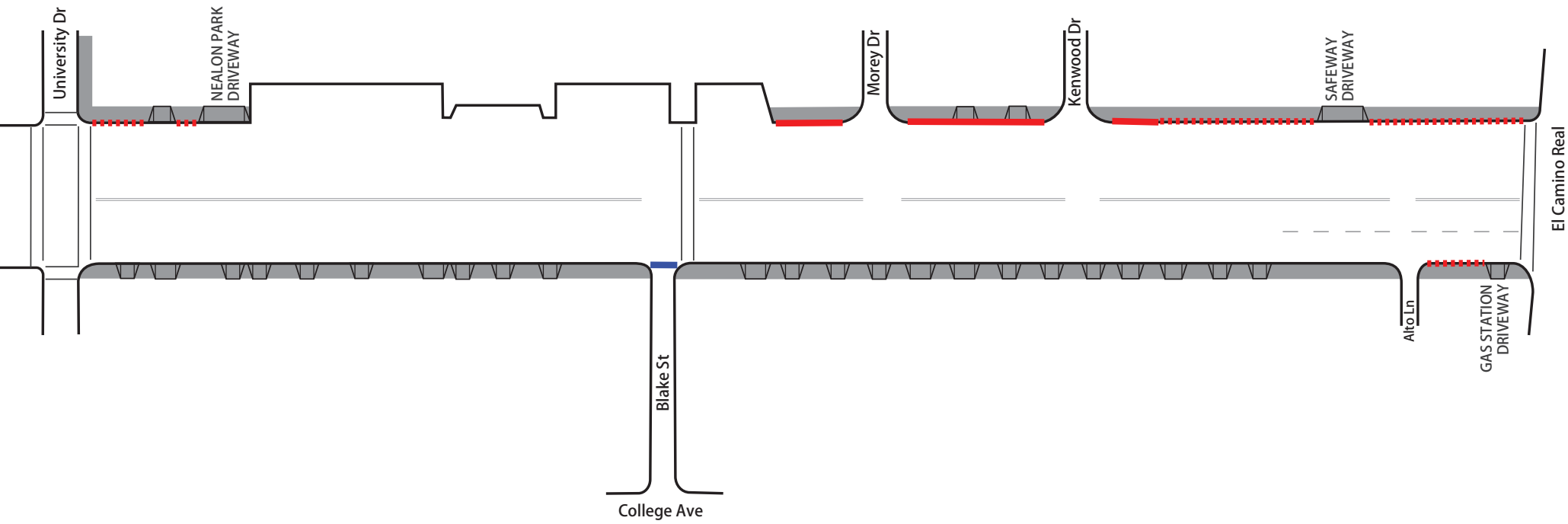
- A. Proposed no parking zones on Middle Avenue and temporary closure of Blake Street at Middle Avenue





| Legends | |
|---|---|
|  | Existing sidewalk |
|  | Existing "no parking" zone |
|  | Proposed "no parking" zone |
|  | Proposed Blake St closure (maintain emergency access) |

El Camino Real - University Drive

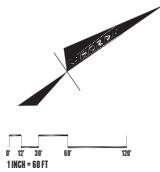

-  Flashing beacon
-  Raised Crosswalk
-  Speed hump
-  Speed feedback sign
-  Curb extension / Bulb-out
-  Stop sign

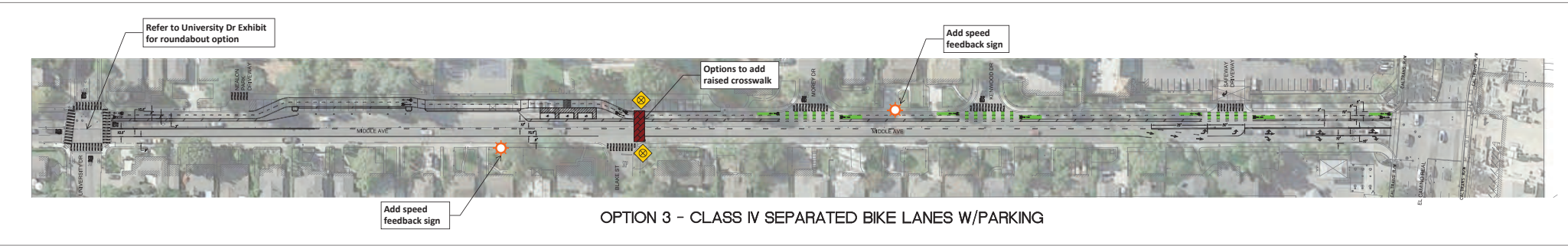
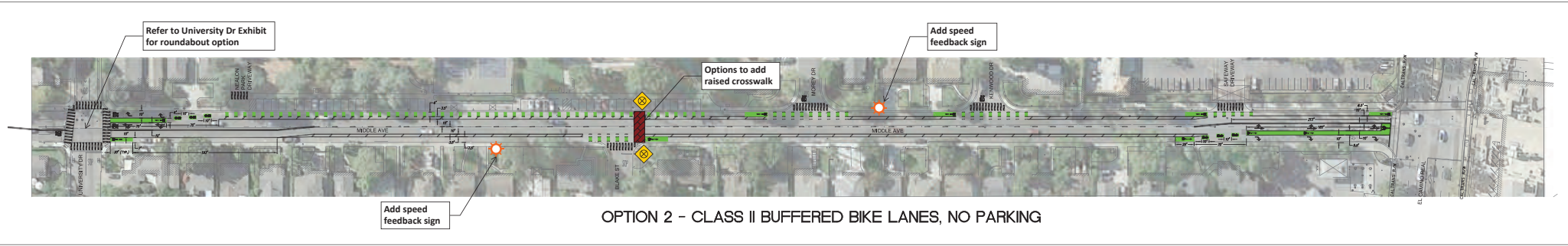
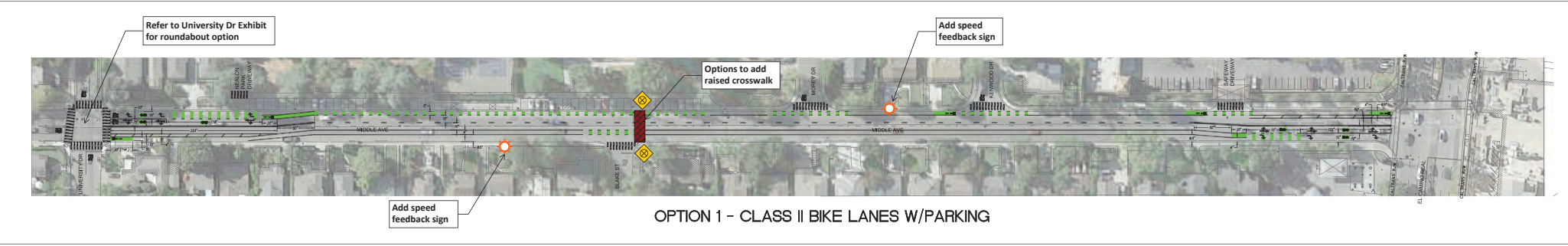

University Drive - San Mateo Drive

◆ Flashing beacon
 ▬ Raised Crosswalk
 ▨ Speed hump
 ⊙ Speed feedback sign
 ▬ Curb extension / Bulb-out
 ● Stop sign

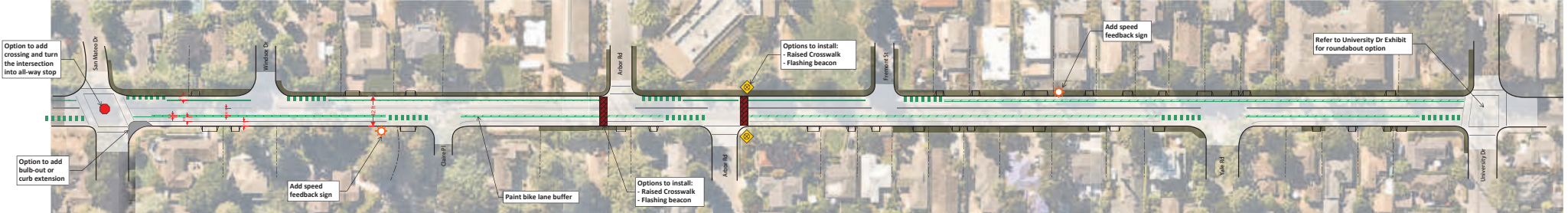

OPTION 1 : CLASS II BIKE LANES W/ PARKING

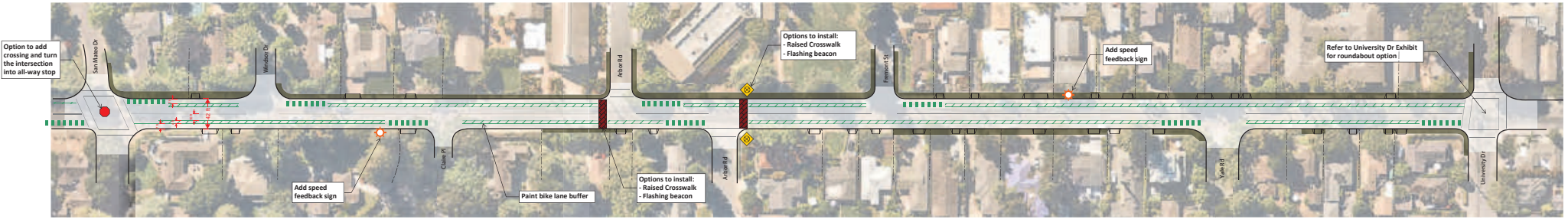

OPTION 2 : CLASS II BUFFERED BIKE LANES, NO PARKING

San Mateo Drive - Olive Street

◆ Flashing beacon
 ■ Raised Crosswalk
 ▨ Speed hump
 ⚙ Speed feedback sign
 ▬ Curb extension / Bulb-out
 ● Stop sign

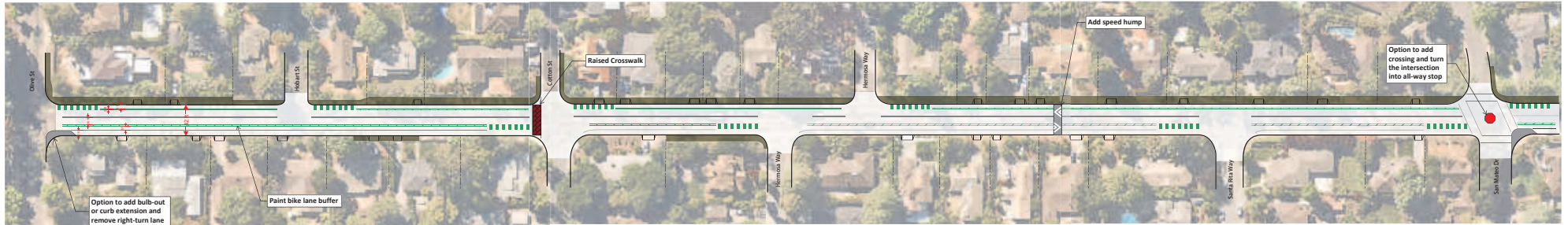

OPTION 1 : CLASS II BIKE LANES W/ PARKING

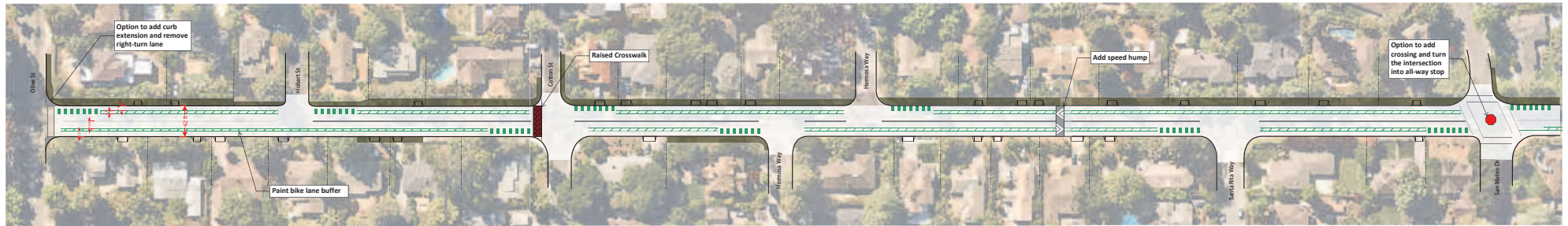

OPTION 2 : CLASS II BUFFERED BIKE LANES, NO PARKING

Middle Avenue Bike Lane Improvement – Residential Areas

← 65 ft City Right of Way →

EXISTING

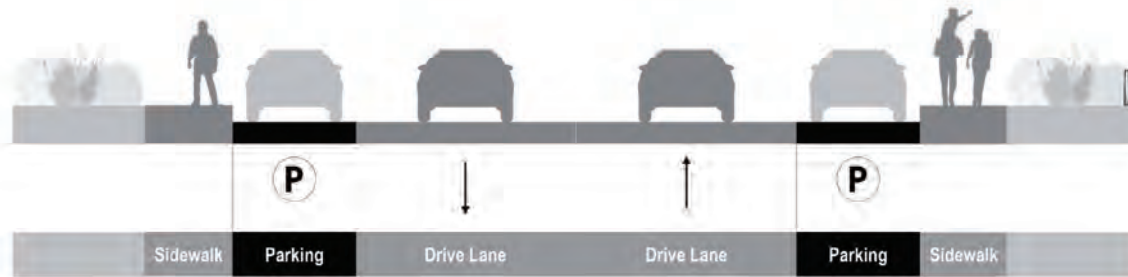

OPTION 1

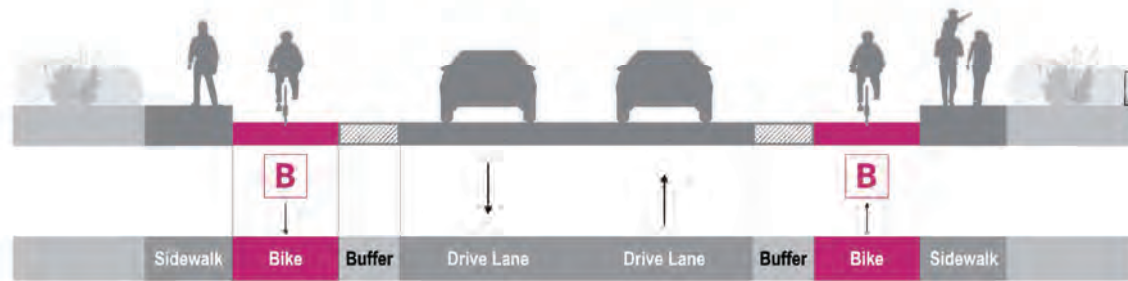

OPTION 2

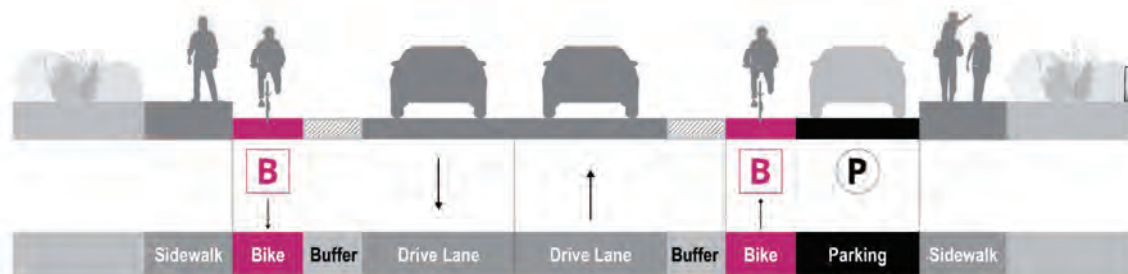

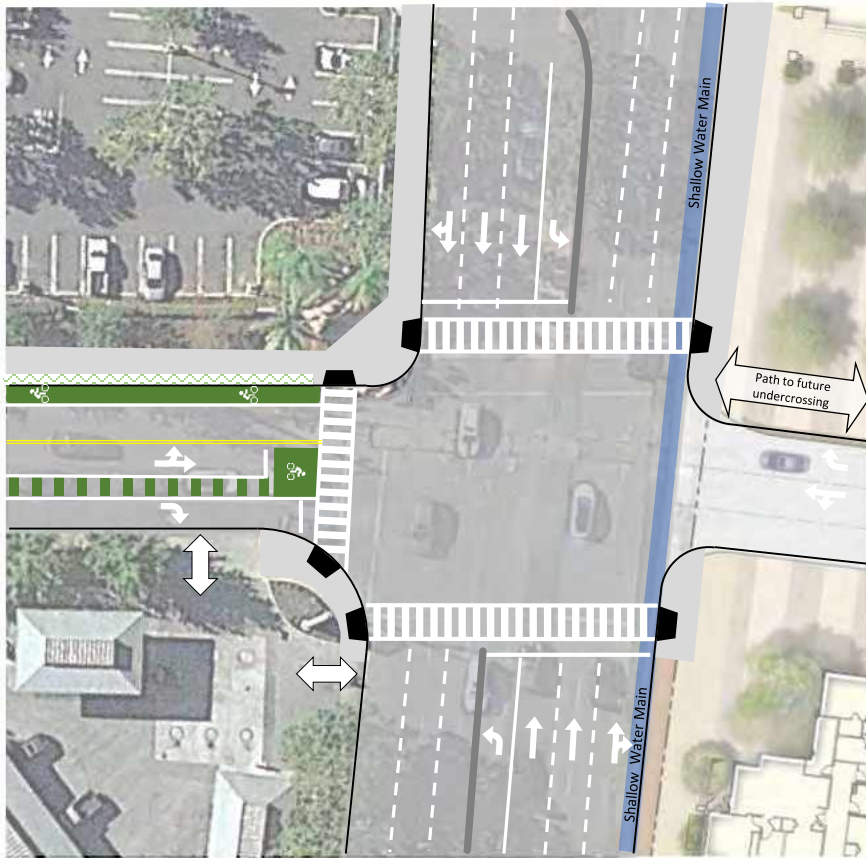

Standard Intersection Treatment

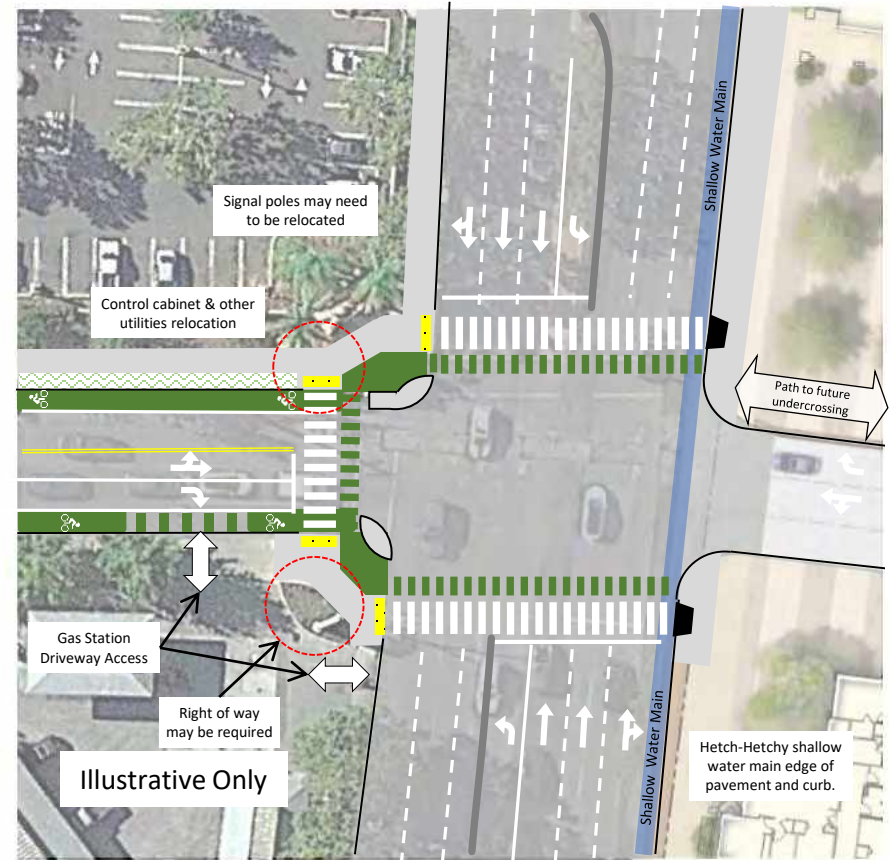

Dedicated Intersection

Notes:

- Improves crossing while there are no bicycle lanes on El Camino Real
- Design would need to consider bus, truck, and large vehicle turning movements at intersection
- Gas station access may limit design options
- Recommend that no right turn on red from Middle Avenue - consider right turn overlap with Northbound left turn

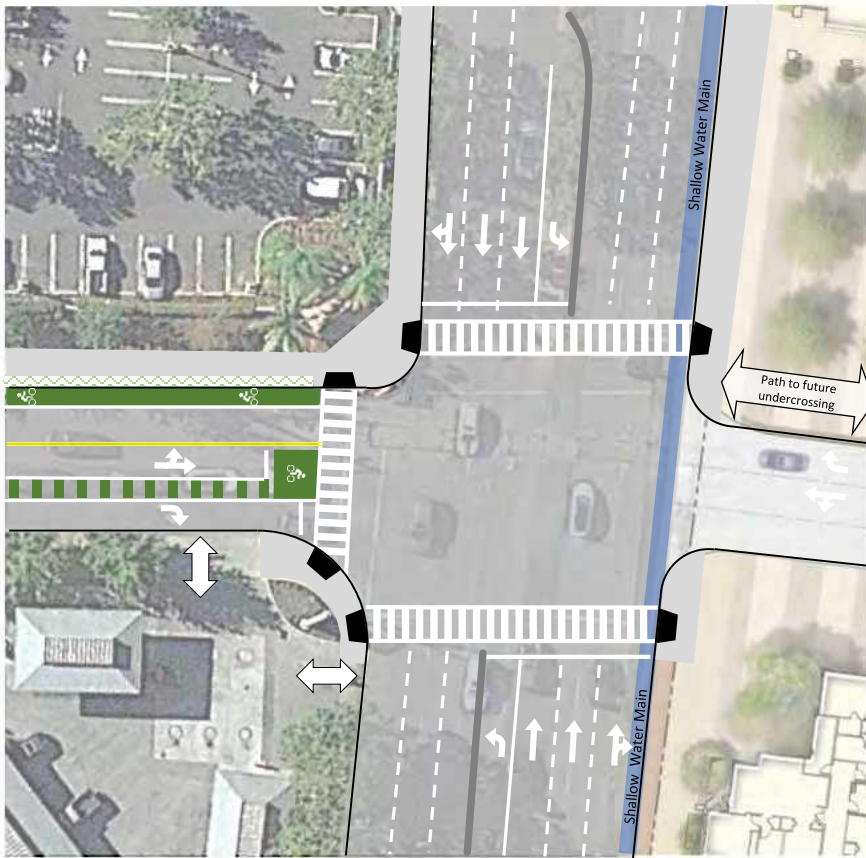

Standard Intersection Treatment

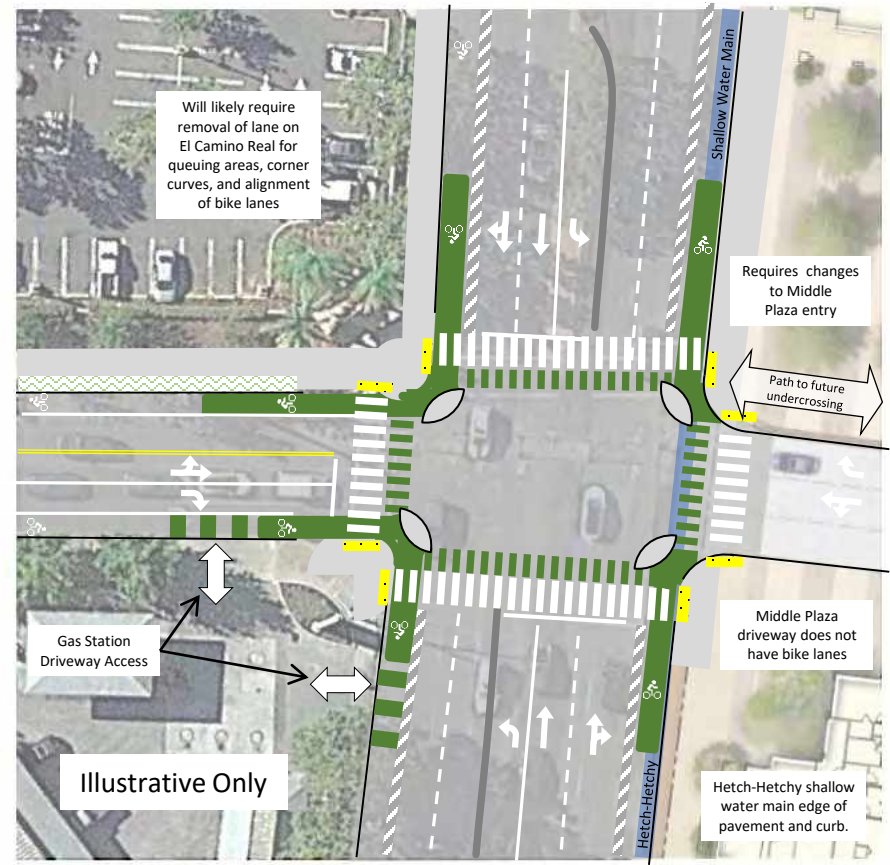

Protected Intersection

Notes:

- Likely requires removal of one travel lane on El Camino Real to align bike lanes and allow for corner curves and protected queuing areas
- Middle Plaza entry has no bicycle lanes on the entry driveway
- Middle Plaza corners need to be modified to accommodate queuing area, any reconstruction would be above the Hetch-Hetchy shallow water main
- Design would need to consider bus, truck, and large vehicle turning movements at intersection
- Gas station access to Middle Avenue would need to be addressed due to proximity to corner and queuing areas
- Recommend no right turn on red from Middle Avenue



Existing Conditions

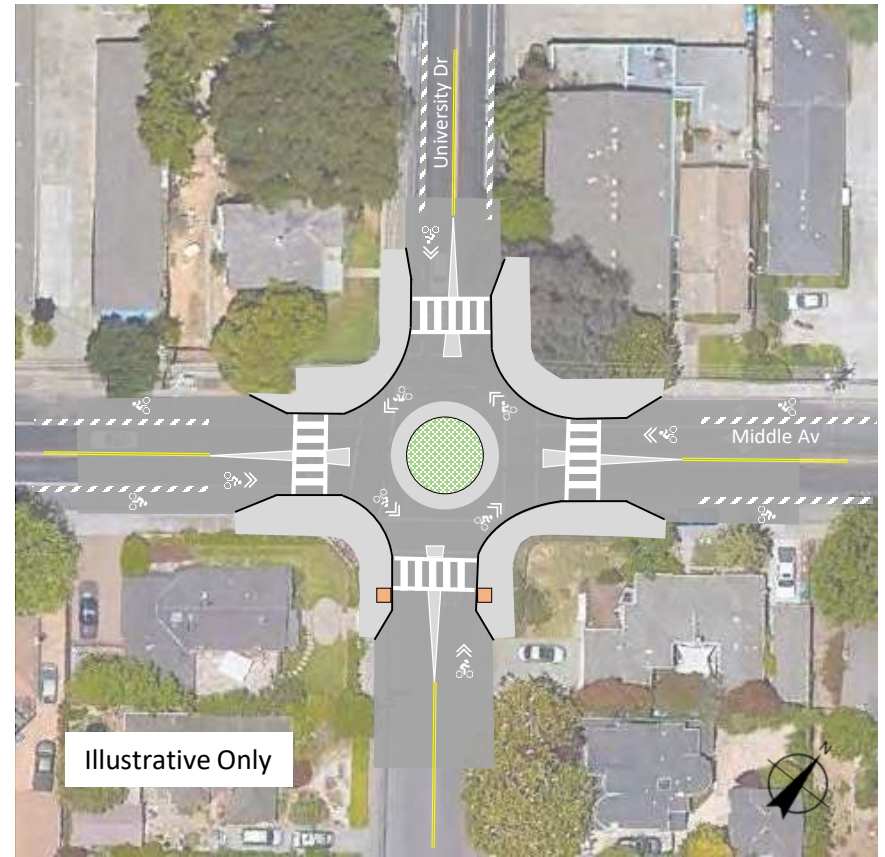

Mini-Roundabout

Notes:

- Assumes that bicyclists share the lane with vehicles in the roundabout
- Slip ramps could be provided at all corners to allow less confident bicyclists to use the sidewalks to navigate the roundabout
- Design would need to consider bus and truck movements

Figure 3B-21 (CA). Examples of Parking Space Markings

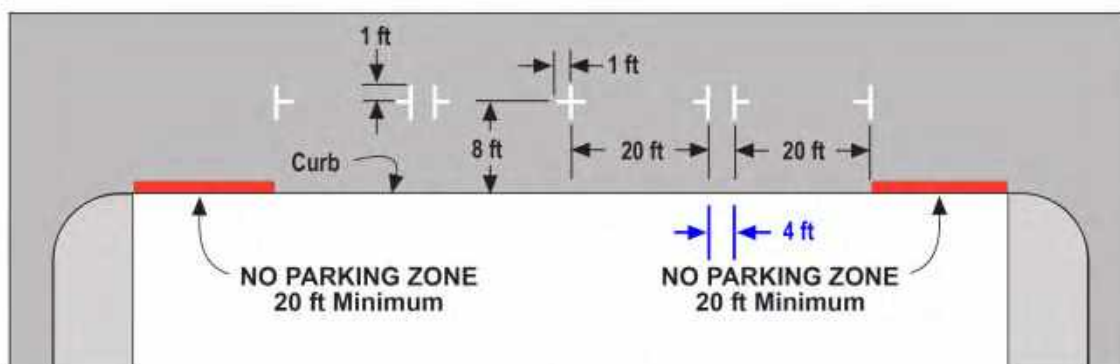
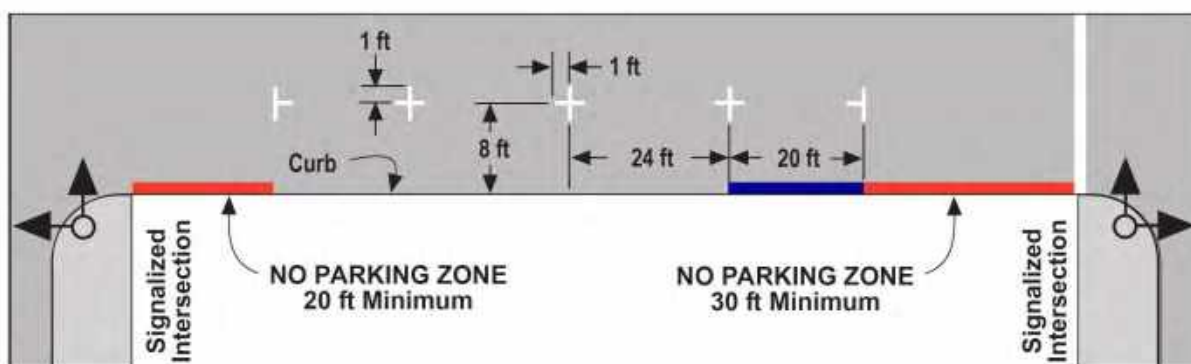
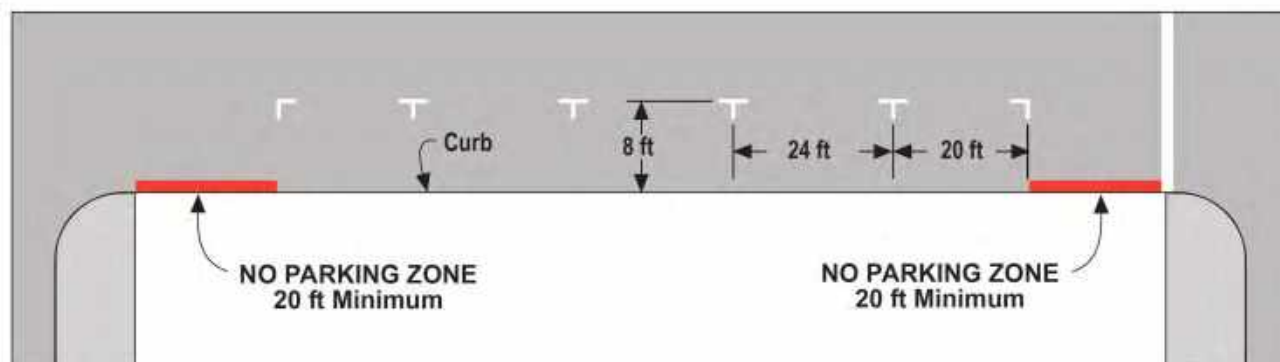

NOT TO SCALE

NOTES:

1. For Parking Stalls along the left side curb on one-way streets, markings may be placed on the curb delineating the ends of the individual stalls.
2. All stall markings are made with 4 in wide white lines. The shape is optional.
3. The parking stall cross line, 8 ft from the curb, may be continuous longitudinally.



STAFF REPORT

City Council

Meeting Date:

9/13/2022

Staff Report Number:

22-170-CC

Regular Business:

Waive the first reading and introduce an ordinance repealing and replacing Menlo Park Municipal Code Section 2.04.190 relating to filling City Council vacancies and adopt a resolution establishing the process for appointment of candidates to City Council seats to fill vacancies

Recommendation

Staff recommends that the City Council take the following actions:

1. Introduce by title only and waive further reading of an ordinance of the City Council of the City of Menlo Park repealing and replacing Section 2.04.190, "Filling of Vacancies on the City Council," of Chapter 2.04 within title 2 of the Menlo Park Municipal Code (MPMC); and
2. Adopt a resolution establishing a process for appointment of candidates to City Council seats in order to fill vacancies on the City Council

Policy Issues

There is currently a conflict between State law and MPMC provisions relating to vacancies. The proposed ordinance would revise MPMC Section 2.04.190 to correct the conflict by identifying the process in Government Code Section 36512 and allowing the City Council to appoint or call a special election to fill the vacancy.

Background

At the August 23, 2022 City Council meeting, the City Council discussed MPMC Section 2.04.190 relating to filling City Council vacancies. Currently, MPMC Section 2.04.190, which codifies Ordinance No. 559, contains timing requirements that directly conflict with Government Code Section 36512. MPMC Section 2.04.190 requires that if a vacancy occurs, the City Council shall call an election to be held at the next regularly scheduled election, at least 89 days after the vacancy is created. Government Code Sections 36512(c)(1-3) specify that the special election shall be held at the next regularly established election date not less than 114 days from the call of the special election or filing of a petition. Because the provisions in MPMC Section 2.04.190 relating to the timing of the election conflict with the language in Government Code Section 36512(c)(1-3), the City would be preempted from relying on the timing requirements in MPMC Section 2.04.190.

The City Council also discussed potential options identified in Government Code Section 36512 for filling vacancies at the August 23 meeting. At that meeting, the City Council directed staff to prepare an ordinance that defaulted to the State process set forth in Government Code Section 36512, allowing City Council to determine each time a vacancy occurs whether to appoint or call a special election. Staff has also prepared a resolution setting forth the process for appointing someone to the City Council should a vacancy occur, and should the City Council elect to fill the vacancy via appointment. The Council may adopt this resolution

at the September 13, 2022 City Council meeting, or the resolution may be adopted when the ordinance comes back to the Council for a second reading.

Analysis

1. Ordinance repealing and replacing MPMC 2.04.190

Based on City Council direction staff prepared an ordinance that would repeal and replace MPMC Section 2.04.190 in its entirety to read as follows:

“If a vacancy occurs in the office of a member of the City Council, the City Council may appoint or call a special election in order to fill the City Council vacancy, in conformance with the provisions of Government Code Section 36512, as that Section may be amended. If the City Council decides to fill the vacancy by appointment, the appointment shall be made pursuant to an appointment process set forth in a separate resolution of the City Council, which resolution may be amended from time to time.”

This change would mean that when a vacancy occurs on the City Council, the City Council would utilize the process identified in Government Code Section 36512, which sets forth the statutory requirements relating to filling vacancies in an elective or appointed office. Subdivision (b) of that Section provides two options to fill a vacancy in an elective office within 60 days from the commencement of the vacancy: either fill the vacancy by appointment or call a special election to fill the vacancy. Subdivision (b) reads in relevant part as follows:

1. If the City Council calls a special election, the special election shall be held on the next regularly established election¹ date not less than 114 days from the call of the special election. A person elected to fill a vacancy holds office for the unexpired term of the former incumbent.
2. If the City Council fills the vacancy by appointment, the person appointed to fill the vacancy shall hold office pursuant to one of the following:
 - A. If the vacancy occurs in the first half of a term of office and at least 130 days before the next general municipal election, the person appointed to fill the vacancy shall hold office until the next general municipal election that is scheduled 130 or more days after the date the City Council is notified of the vacancy, and thereafter until the person who is elected at that election to fill the vacancy has been qualified. The person elected to fill the vacancy shall hold office for the unexpired balance of the term of office.
 - B. If the vacancy occurs in the first half of a term of office, but less than 130 days before the next general municipal election, or if the vacancy occurs in the second half of a term of office, the person appointed to fill the vacancy shall hold office for the unexpired term of the former incumbent.

This proposed ordinance would eliminate the conflict between State law and MPMC Section 2.04.190 relating to timing.

2. Process for appointment

The revisions to MPMC Section 2.04.090 would provide that the appointment shall be made pursuant to an appointment process set forth in a separate Resolution of the City Council. Staff has drafted a proposed process for the City Council's consideration that provides the following process:

- A. Upon determination that the City Council desires to appoint someone to a vacant City Council seat, the city clerk shall publish a notice of the vacancy in a newspaper of general circulation, advertise in local online media and social media, and post on the City's website at least two weeks before the meeting at

¹ While there is no definition for “regularly established election” as used in Government Code § 36512(b), it can reasonably be construed to mean an election established by the City Council following the requirements for holding a special election.

which the City Council will consider candidates to fill a vacated position. The city clerk may also develop an application to be submitted by the candidates.

- B. The notice shall provide:
1. The District in which the City Council vacancy has occurred;
 2. The date, time, and place of the meeting where the City Council will conduct interviews and appoint a candidate to fill the vacancy;
 3. The deadline for submitting an interested person's name and other identified information or application prepared by the city clerk; and
 4. Information about the Questionnaire identified in Section C below and where a copy of the Questionnaire may be obtained.
- C. An individual who is interested in filling the vacancy shall be requested to provide written answers to questions, which are attached hereto as Exhibit A ("Questionnaire") on the date specified by the city clerk so that the Questionnaire can be included in the agenda package and made public for the meeting at which the City Council conducts interviews of City Council candidates. If the Questionnaire is not provided on or before the date specified by the city clerk, the candidate shall not be interviewed by the City Council.
- D. Qualified Candidates. The city clerk shall review the submittals from the candidates to ensure that each candidate resides in the District where the vacancy has occurred and has submitted all required documents to confirm that the candidate is a qualified candidate ("Qualified Candidates.")
- E. Interviews of Qualified Candidates shall take place during a regular or special City Council meeting, as determined appropriate by the Mayor and the city manager. The following procedures shall govern the interview process:
1. Order of Interview. Before commencement of the interviews, candidates shall be placed in a random drawing to determine the order in which candidates are interviewed.
 2. Introductions. Candidates shall each be allotted five minutes to introduce themselves to the City Council. Time limits shall be strictly enforced during this phase of the interview. Candidates may all be present at the same time that another candidate is being interviewed.
 3. Questions. To ensure equal opportunity and standardization, each City Councilmember will have an opportunity to ask questions of the candidates from the list of questions in the Questionnaire or follow-up questions to responses that the candidate provided to the Questionnaire. Additional questions not included in the Questionnaire may be asked if approved by the Mayor.
 4. Public Comment. The City Council shall hear from members of the public after the City Council has asked all questions of the candidates.
 5. Discussion. The City Council shall have the opportunity to discuss and deliberate the candidates.
- F. Election by Motion. At the conclusion of discussion, any voting City Councilmember may move to appoint one of the candidates to the vacant office. This motion must be supported by a majority of the City Council. If the motion fails, the nominations shall continue in order until a motion is supported by a majority of the City Council.
- G. Appointment and Swearing In. Upon the affirmative vote of the City Council, the selected individual may be sworn in during that meeting or the City Council may direct the swearing in of the candidate to take place at a future City Council meeting. The newly appointed City Councilmember shall be eligible to take part in City Council meetings after being sworn into office.

There is no standard policy for appointment of someone to the City Council and the City Council has discretion to establish an appointment process. Adopting a process for appointment would eliminate any uncertainty for both the City Council and potential candidates on how an appointment to a City Council seat would be conducted when a vacancy occurs.

Impact on City Resources

As of August 2022, the estimated cost of consolidated election services for one City Councilmember seat is approximately between \$12,100 and \$14,533.

Environmental Review

The proposed actions would be exempt from environmental review as the adoption of the proposed ordinance and resolution do not qualify as a “project” pursuant to Public Resource Code Section 21065 and California Environmental Quality Act (CEQA) Guidelines Sections 15320, 15378 and 15061(b)(3), since it can be seen with certainty that there is no possibility that adoption of the resolution or ordinance would cause either a direct physical change in the environment, or a reasonably foreseeable indirect physical change in the environment.

Public Notice

Public notification was achieved by posting the agenda, with the agenda items being listed, at least 72 hours prior to the meeting.

Attachments

- A. Proposed ordinance
- B. Proposed resolution

Report prepared by:
Nira Doherty, City Attorney

Report reviewed by:
Justin Murphy, City Manager
Judi A. Herren, Assistant to the City Manager/City Clerk

ORDINANCE NO. XXXX

**ORDINANCE OF THE CITY COUNCIL OF THE CITY OF MENLO PARK
REPEALING AND REPLACING SECTION 2.04.190, "FILLING OF VACANCIES
ON THE CITY COUNCIL," OF CHAPTER 2.04 WITHIN TITLE 2 OF THE MENLO
PARK MUNICIPAL CODE**

WHEREAS, in 1974, the City Council adopted Ordinance No. 559 establishing a process for filling vacancies on the City Council; and

WHEREAS, Ordinance No. 559 is codified in Section 2.04.190 of the Menlo Park Municipal Code; and

WHEREAS, on August 23, 2022, the City Council discussed the various options available to public agencies to fill vacancies of elected officers; and

WHEREAS, the City Council desires to repeal Section 2.04.190 and replace the provision with language that conforms to the requirements in Government Code Section 36512, which provides, among other things, that a city may appoint or call a special election within sixty (60) days of a vacancy.

NOW, THEREFORE, BE IT ORDAINED BY THE CITY COUNCIL OF THE CITY OF MENLO PARK:

SECTION 1. Findings.

The above recitals are hereby declared to be true and correct findings of the City Council of the City of Menlo Park.

SECTION 2. Repeal and Replace. Section 2.04.190 - Filling of vacancies on the City Council of Chapter 2.04 - City Council of Title 2 - Administration and Personnel of the Menlo Park Municipal Code is hereby repealed in its entirety and replaced to read as follows:

"Section 2.04.190-Filling of vacancies on the City Council
If a vacancy occurs in the office of a member of the City Council, the City Council may appoint or call a special election in order to fill the City Council vacancy, in conformance with the provisions of Government Code Section 36512, as that Section may be amended. If the City Council decides to fill the vacancy by appointment, the appointment shall be made pursuant to an appointment process set forth in a separate resolution of the City Council, which resolution may be amended from time to time."

SECTION 3. Severability.

If any provision or clause of this ordinance or the application thereof to any person or circumstance is held to be unconstitutional or to be otherwise invalid by a final judgment of any court or competent jurisdiction, such invalidity shall not affect other provisions or clauses or application, and to this end, the provisions and clauses of this ordinance are declared to be severable.

SECTION 4. California Environmental Quality Act.

This Ordinance is not subject to review under the California Environmental Quality Act (CEQA) pursuant to Public Resources Code Section 21000, et seq. and the CEQA

Guidelines (14 Cal. Code Regs. §§ 15000 et. seq.), including without limitation, Public Resources Code Section 21065 and California Code of Regulations 15378 as this is not a “project” that may cause a direct, or reasonably foreseeable indirect, physical change in the environment and if a “project,” is exempt under the “common sense” exception (14 Cal. Code Regs. § 15061(b)(3)) because it can be seen with certainty that there is no possibility that this action may have a significant effect on the environment.

SECTION 5. Publication; Effective Date.

This Ordinance shall be published once, in full or in summary form, after its final passage, in a newspaper of general circulation, published, and circulated in the City of Menlo Park, and shall be in full force and effect immediately upon adoption pursuant to Government Code Section 36937, as this Ordinance relates to an election. If published in summary form, the summary shall also be published within fifteen (15) days after the adoption, together with the names of those City Councilmembers voting for or against same, in a newspaper of general circulation published and circulated in the City of Menlo Park, County of San Mateo, State of California.

INTRODUCED on the thirteenth day of September, 2022.

PASSED AND ADOPTED as an ordinance of the City of Menlo Park at a regular meeting of said City Council on the __ day of __, 2022, by the following votes:

AYES:

NOES:

ABSENT:

ABSTAIN:

APPROVED:

Betsy Nash, Mayor

ATTEST:

Judi A. Herren, City Clerk

RESOLUTION NO. XXXX**RESOLUTION OF THE CITY COUNCIL OF MENLO PARK ESTABLISHING A PROCESS FOR APPOINTMENT OF CANDIDATES TO CITY COUNCIL SEATS IN ORDER TO FILL A VACANCY ON THE CITY COUNCIL**

WHEREAS, on the ___ day of ___, 2022 the City Council of the City of Menlo Park adopted Ordinance No. XXXX, amending Menlo Park Municipal Code Section 2.04.190 pertaining to the filling of City Council vacancies to conform to the process identified in Government Code Section 36512; and

WHEREAS, the City Council desires to establish via resolution a process that shall be utilized in the event of a vacancy on the City Council and the City Council decides to appoint someone to a City Council seat in accordance with Section 2.04.190 and Government Code Section 36512.

NOW THEREFORE, THE CITY COUNCIL OF THE CITY OF MENLO PARK DOES HEREBY RESOLVE AS FOLLOWS:

Section 1. Recitals. The City Council hereby finds that the foregoing recitals are a true and accurate and are incorporated herein by reference.

Section 2. California Environmental Quality Act (CEQA) Determination. This action is exempt from environmental review as the adoption of this resolution does not qualify as a “project” pursuant to Public Resource Code Section 21065 and CEQA Guidelines Sections 15320, 15378 and 15061(b)(3), since it can be seen with certainty that there is no possibility that adoption of this resolution would cause either a direct physical change in the environment, or a reasonably foreseeable indirect physical change in the environment.

Section 3. Process for Appointment.

- A. Upon determination that the City Council desires to appoint someone to a vacant City Council seat, the City Clerk shall publish a notice of the vacancy in a newspaper of general circulation, advertise in local online media and social media, and post on the City’s website at least two weeks before the meeting at which the City Council will consider candidates to fill a vacated position. The City Clerk may also develop an application to be submitted by the candidates.
- B. The notice shall provide:
 1. The District in which the City Council vacancy has occurred;
 2. The date, time, and place of the meeting where the City Council will conduct interviews and appoint a candidate to fill the vacancy;
 3. The deadline for submitting an interested person’s name and other identified information or application prepared by the City Clerk; and
 4. Information about the Questionnaire identified in Section C below and where a copy of the Questionnaire may be obtained.
- C. An individual who is interested in filling the vacancy shall be requested to provide written answers to questions, which are attached hereto as Exhibit A (“Questionnaire”) on the date specified by the City Clerk so that the Questionnaire can be included in the agenda package and made public for the meeting at which the City Council conducts interviews of City Council candidates. If the Questionnaire is not provided on or before the date specified by the City Clerk, the candidate shall not be interviewed by the City Council.
- D. Qualified Candidates. The City Clerk shall review the submittals from the candidates to ensure that each candidate resides in the District where the vacancy has occurred and has

submitted all required documents to confirm that the candidate is a qualified candidate (“Qualified Candidates”).

- E. Interviews of Qualified Candidates shall take place during a regular or special City Council meeting, as determined appropriate by the Mayor and the City Manager. The following procedures shall govern the interview process:
 - 1. Order of Interview. Before commencement of the interviews, candidates shall be placed in a random drawing to determine the order in which candidates are interviewed.
 - 2. Introductions. Candidates shall each be allotted five minutes to introduce themselves to the City Council. Time limits shall be strictly enforced during this phase of the interview. Candidates may all be present at the same time that another candidate is being interviewed.
 - 3. Questions. To ensure equal opportunity and standardization, each City Councilmember will have an opportunity to ask questions of the candidates from the list of questions in the Questionnaire or follow-up questions to responses that the candidate provided to the Questionnaire. Additional questions not included in the Questionnaire may be asked if approved by the Mayor.
 - 4. Public Comment. The City Council shall hear from members of the public after the City Council has asked all questions of the candidates.
 - 5. Discussion. The City Council shall have the opportunity to discuss and deliberate the candidates.
- F. Election by Motion. At the conclusion of discussion, any voting City Councilmember may move to appoint one of the candidates to the vacant office. This motion must be supported by a majority of the City Council. If the motion fails, the nominations shall continue in order until a motion is supported by a majority of the City Council.
- G. Appointment and Swearing In. Upon the affirmative vote of the City Council, the selected individual may be sworn in during that meeting or the City Council may direct the swearing in of the candidate to take place at a future City Council meeting. The newly appointed City Councilmember shall be eligible to take part in City Council meetings after being sworn into office.

Section 4. Effective Date of Resolution. This resolution shall take effect immediately upon its adoption.

Section 5. Severability. If any section, subsection, sentence, clause, phrase, or portion of this resolution is for any reason held to be invalid or unenforceable by a court of competent jurisdiction, the remaining portions of this resolution shall nonetheless remain in full force and effect. The City Council hereby declares that it would have adopted each section, subsection, sentence, clause, phrase, or portion of this resolution, irrespective of the fact that any one or more sections, subsections, sentences, clauses, phrases, or portions of this resolution be declared invalid or unenforceable.

//

//

//

//

//

I, Judi A. Herren, City Clerk of Menlo Park, do hereby certify that the above and foregoing City Council Resolution was duly and regularly passed and adopted at a meeting by said City Council on the __ day of September, 2022, by the following votes:

AYES:

NOES:

ABSENT:

ABSTAIN:

IN WITNESS WHEREOF, I have hereunto set my hand and affixed the Official Seal of said City on this __ day of September, 2022.

Judi A. Herren, City Clerk

Exhibits:

A. Questionnaire

QUESTIONNAIRE

Please answer the following questions.

1. Have you ever held a public office? If yes, name the office title, dates of service and describe the duties.
2. Please describe your qualifications, education and work experience/training that you believe would be relevant in your role as a City Councilmember.
3. What has your previous involvement with the City of Menlo Park? Please include any service organizations or community engagement in which you have participated.
4. Are you aware of the time commitment and the responsibilities associated with serving as a City Councilmember and are you prepared to serve without reservation?
5. Do you have any duties or responsibilities that would conflict with the duties of a City Councilmember?
6. Please describe the top three immediate issues that you think the City Council needs to address in Menlo Park.
7. Please describe the top three long-term issues that you think the City Council needs to address in Menlo Park.
8. What improvements do you think can be made in the City of Menlo Park?
9. Why do you think you are qualified to be appointed to the vacant City Council seat?
10. Is there anything else you would like to share with the City Council?



STAFF REPORT

City Council

Meeting Date:

9/13/2022

Staff Report Number:

22-169-CC

Regular Business:

Adopt a resolution to approve amendments to the salary schedule as of September 25, 2022

Recommendation

City staff recommends that the City Council approve an amendment to the salary schedule adding public works supervisor - trees

Policy Issues

The City Council retains sole authority to amend the salary schedule and budget for full-time equivalent personnel (FTEs.)

Background

The salary schedule identifies job classifications that have been approved by City Council (e.g., accountant, administrative assistant) and the hourly rates of pay for each classification at each step. The requested change to the salary schedule establishes the range for the classification that is critical to the preservation of the urban tree canopy. As part of the fiscal year 2021-22 adopted budget, the City Council authorized a service level enhancement for the city tree program, by adding 1 FTE to the tree maintenance crew, for a total of 3.0 maintenance workers, 1.0 senior maintenance worker, and 1.0 city arborist. While the trees section was fully staffed at this level during the fall and winter of 2021-22, two of the three maintenance worker positions are currently vacant and the current city arborist began employment with the city in the spring of 2022. The public works department is struggling to maintain a high level of customer service in daily operations and respond to emergency tree requests with these two vacancies in the trees section. Given ongoing drought conditions and the approaching fall weather, staffing in the trees section is critical to provide adequate response capabilities during storm events, including downed trees and limbs that occur from wind and rain.

The requested salary schedule amendment would convert a senior maintenance worker position to a newly created classification, public works supervisor – trees with no requested increase in FTEs. This would provide opportunities for employee development and advancement, support employee retention, and improve operations by providing clearer division of responsibilities between the city arborist and the public works supervisor – trees position. The city arborist will maintain responsibility for the overall preservation of the urban tree canopy and oversight of the tree program, and continue to be the point of contact for tree removal permit applications and implementation of the heritage tree ordinance requirements. The public works supervisor – trees position will oversee the daily operations of the in-house tree maintenance crew (3.0 FTEs), manage the tree maintenance contract with West Coast Arborists, and be responsible to provide a high level of customer service interacting with the public on tree-related requests in the public right-of-way and parks.

Analysis

Attachment A is the resolution or enabling action necessary to amend the City Council adopted salary schedule, Attachment B.

The public works supervisor - trees is a middle management classification responsible for supervision of tree maintenance staff and contractors related to tree maintenance operations. Consistent with past practice for represented classifications, salary ranges for new classifications are set based on internal alignment to protect against salary compaction. With public works possessing middle management classifications equivalent to public works supervisor - trees, the public works supervisor for parks as well as streets classifications, the recommended salary range for the public works supervisor - trees is at the same level in recognition of the similarities in expectations of the position. Accordingly, the salary range recommended for public works supervisor - trees is \$100,707 to \$121,388.

Impact on City Resources

The public works supervisor – trees classification represents a transition of an existing FTE employee, senior maintenance worker – trees; therefore, does not require a budget amendment for fiscal year 2022-23 due to the fact that the increased cost would be absorbed by the current vacancy factor. The maximum annualized cost differential between a senior maintenance worker – trees and public works supervisor - trees is approximately \$32,956.

Environmental Review

This action is not a project within the meaning of the California Environmental Quality Act (CEQA) Guidelines §§ 15378 and 15061(b)(3) as it will not result in any direct or indirect physical change in the environment.

Public Notice

Public notification was achieved by posting the agenda, with the agenda items being listed, at least 72 hours prior to the meeting.

Attachments

- A. Resolution adopting an amendment to the salary schedule
- B. Salary schedule for fiscal year 2022-2023 – effective 9/25/2022 (amended)

Report prepared by:

Mary Morris-Mayorga, Administrative Services Director–Extra Help Retired Annuitant
Nikki Nagaya, Public Works Director

RESOLUTION NO. XXXX

**RESOLUTION OF THE CITY COUNCIL OF THE CITY OF MENLO PARK
AMENDING THE SALARY SCHEDULE EFFECTIVE SEPTEMBER 25, 2022**

WHEREAS, pursuant to the Personnel System Rules, the City Manager prepared a Compensation Plan; and

NOW, THEREFORE BE IT RESOLVED that the following compensation provisions shall be established in accordance with the City's Personnel System rules.

BE IT FURTHER RESOLVED that any previous enacted compensation provisions contained in Resolution No. 6754 remain with the addition of one classification provided in Table 1:

| Table 1: Salary schedule addition | | | | | |
|-----------------------------------|--------------------|-----------|-----------|-----------|--------------------|
| Classification title | Minimum/ Step A | Step B | Step C | Step D | Maximum/ Step E |
| Public Works Supervisor - Trees | \$100,707 | \$105,534 | \$110,563 | \$115,845 | \$121,388 |

BE IT FURTHER RESOLVED that the changes herein shall be effective September 25, 2022.

I, Judi A. Herren, City Clerk of Menlo Park, do hereby certify that the above and foregoing City Council Resolution was duly and regularly passed and adopted at a meeting by said City Council on the thirteenth day of September, 2022, by the following votes:

AYES:

NOES:

ABSENT:

ABSTAIN:

IN WITNESS WHEREOF, I have hereunto set my hand and affixed the Official Seal of said City on this ___ day of September, 2022.

Judi A. Herren, City Clerk

City of Menlo Park
Salary Schedule - effective 09/25/2022
PROPOSED

| Classification Title | Minimum (Step A) | Step B | Step C | Step D | Maximum (Step E) |
|---|------------------|------------|-------------|------------|------------------|
| Accountant I | \$ 87,734 | \$ 92,122 | \$ 96,728 | \$ 101,565 | \$ 106,643 |
| Accountant II | \$ 96,095 | \$ 100,637 | \$ 105,385 | \$ 110,453 | \$ 115,717 |
| Accounting Assistant I | \$ 62,216 | \$ 65,165 | \$ 68,174 | \$ 71,359 | \$ 74,661 |
| Accounting Assistant II | \$ 68,174 | \$ 71,359 | \$ 74,661 | \$ 78,150 | \$ 81,818 |
| Administrative Assistant | \$ 68,379 | \$ 71,573 | \$ 74,885 | \$ 78,385 | \$ 82,063 |
| Administrative Services Director | \$ 165,347 | | Open Range | | \$ 234,259 |
| Assistant Administrative Services Director | \$ 130,376 | | Open Range | | \$ 187,407 |
| Assistant City Manager | \$ 174,616 | | Open Range | | \$ 257,685 |
| Assistant Community Development Director | \$ 130,376 | | Open Range | | \$ 187,407 |
| Assistant Community Services Director | \$ 133,380 | | Open Range | | \$ 187,407 |
| Assistant Engineer | \$ 105,817 | \$ 110,859 | \$ 116,160 | \$ 121,705 | \$ 127,503 |
| Assistant Library Services Director | \$ 133,380 | | Open Range | | \$ 187,407 |
| Assistant Planner | \$ 95,875 | \$ 100,383 | \$ 105,195 | \$ 110,208 | \$ 115,473 |
| Assistant Public Works Director | \$ 144,870 | | Open Range | | \$ 187,407 |
| Assistant to the City Manager | \$ 125,490 | | Open Range | | \$ 163,981 |
| Assistant to the City Manager / City Clerk | \$ 125,490 | | Open Range | | \$ 163,981 |
| Assistant Transportation Planner | \$ 95,875 | \$ 100,383 | \$ 105,195 | \$ 110,208 | \$ 115,473 |
| Associate Civil Engineer | \$ 118,735 | \$ 124,419 | \$ 130,350 | \$ 136,648 | \$ 143,267 |
| Associate Engineer | \$ 112,205 | \$ 117,576 | \$ 123,182 | \$ 129,133 | \$ 135,388 |
| Associate Planner | \$ 105,195 | \$ 110,208 | \$ 115,473 | \$ 120,998 | \$ 126,789 |
| Associate Transportation Engineer | \$ 124,419 | \$ 130,350 | \$ 136,648 | \$ 143,267 | \$ 150,209 |
| Associate Transportation Planner | \$ 105,195 | \$ 110,208 | \$ 115,473 | \$ 120,998 | \$ 126,789 |
| Asst. Public Works Director - Engineering | \$ 144,870 | | Open Range | | \$ 187,407 |
| Asst. Public Works Director - Maintenance | \$ 144,870 | | Open Range | | \$ 187,407 |
| Asst. Public Works Director - Transportation | \$ 144,870 | | Open Range | | \$ 187,407 |
| Building Custodian | \$ 62,154 | \$ 65,100 | \$ 68,106 | \$ 71,288 | \$ 74,587 |
| Building Inspector I | \$ 92,657 | \$ 97,113 | \$ 101,742 | \$ 106,606 | \$ 111,696 |
| Building Inspector II | \$ 101,923 | \$ 106,824 | \$ 111,916 | \$ 117,266 | \$ 122,866 |
| Business Manager | \$ 105,192 | \$ 110,250 | \$ 115,505 | \$ 121,028 | \$ 126,807 |
| Chief Water Operator | \$ 101,983 | \$ 106,843 | \$ 111,948 | \$ 117,304 | \$ 122,918 |
| Child Care Teacher I | \$ 55,614 | \$ 58,136 | \$ 60,769 | \$ 63,538 | \$ 66,544 |
| Child Care Teacher II | \$ 62,154 | \$ 65,100 | \$ 68,106 | \$ 71,288 | \$ 74,587 |
| Child Care Teacher's Aide | \$ 41,726 | \$ 43,614 | \$ 45,587 | \$ 47,629 | \$ 49,732 |
| City Arborist | \$ 105,789 | \$ 110,860 | \$ 116,143 | \$ 121,691 | \$ 127,514 |
| City Clerk | \$ 125,490 | | Open Range | | \$ 163,981 |
| City Councilmember | n/a | | Annual Rate | | \$ 7,680 |
| City Manager | \$ 203,533 | | Open Range | | \$ 281,111 |
| Code Enforcement Officer | \$ 87,678 | \$ 91,822 | \$ 96,153 | \$ 100,778 | \$ 105,581 |
| Communications and Records Manager | \$ 121,823 | \$ 127,735 | \$ 133,870 | \$ 140,325 | \$ 147,074 |
| Communications Dispatcher | \$ 88,905 | \$ 93,108 | \$ 97,500 | \$ 102,189 | \$ 107,059 |
| Communications Training Dispatcher | \$ 93,108 | \$ 97,500 | \$ 102,189 | \$ 107,059 | \$ 112,178 |
| Community Development Director | \$ 165,126 | | Open Range | | \$ 234,259 |
| Community Development Technician | \$ 74,567 | \$ 78,019 | \$ 81,665 | \$ 85,496 | \$ 89,514 |
| Community Service Officer | \$ 72,907 | \$ 76,336 | \$ 79,871 | \$ 83,662 | \$ 87,678 |
| Construction Inspector I | \$ 87,412 | \$ 91,617 | \$ 95,983 | \$ 100,572 | \$ 105,374 |
| Construction Inspector II | \$ 96,153 | \$ 100,778 | \$ 105,581 | \$ 110,629 | \$ 115,911 |
| Contracts Specialist | \$ 76,990 | \$ 80,610 | \$ 84,343 | \$ 88,347 | \$ 92,587 |
| Custodial Services Supervisor | \$ 71,518 | \$ 74,828 | \$ 78,324 | \$ 82,000 | \$ 85,853 |
| Deputy City Clerk | \$ 79,862 | \$ 83,662 | \$ 87,678 | \$ 91,822 | \$ 96,153 |
| Deputy City Manager | \$ 169,611 | | Open Range | | \$ 234,259 |
| Deputy Comm. Dev. Director - Housing | \$ 130,350 | | Open Range | | \$ 175,695 |
| Economic Development Manager | \$ 125,490 | | Open Range | | \$ 163,981 |
| Engineering Services Manager | \$ 130,350 | | Open Range | | \$ 175,695 |
| Engineering Technician I | \$ 80,152 | \$ 83,864 | \$ 87,845 | \$ 92,061 | \$ 96,413 |
| Engineering Technician II | \$ 89,855 | \$ 94,082 | \$ 98,506 | \$ 103,229 | \$ 108,148 |
| Enterprise Applications Administrator | \$ 118,341 | \$ 123,962 | \$ 129,850 | \$ 136,083 | \$ 142,657 |
| Enterprise Applications Support Specialist I | \$ 94,840 | \$ 99,582 | \$ 104,561 | \$ 109,789 | \$ 115,279 |
| Enterprise Applications Support Specialist II | \$ 105,192 | \$ 110,250 | \$ 115,505 | \$ 121,028 | \$ 126,807 |
| Equipment Mechanic | \$ 79,862 | \$ 83,662 | \$ 87,678 | \$ 91,822 | \$ 96,153 |
| Executive Assistant | \$ 78,073 | \$ 81,736 | \$ 85,576 | \$ 89,602 | \$ 93,816 |
| Executive Assistant to the City Mgr | \$ 83,173 | \$ 87,331 | \$ 91,698 | \$ 96,283 | \$ 101,096 |
| Extra Help Retired Annuitant | \$ 31,200 | | Open Range | | \$ 249,600 |
| Facilities Maintenance Technician I | \$ 66,544 | \$ 69,608 | \$ 72,907 | \$ 76,336 | \$ 79,871 |
| Facilities Maintenance Technician II | \$ 72,907 | \$ 76,336 | \$ 79,871 | \$ 83,662 | \$ 87,678 |
| Finance and Budget Manager | \$ 130,350 | | Open Range | | \$ 175,695 |
| Finance Director | \$ 165,125 | | Open Range | | \$ 234,259 |
| GIS Analyst I | \$ 92,043 | \$ 96,646 | \$ 101,479 | \$ 106,553 | \$ 111,881 |
| GIS Analyst II | \$ 105,192 | \$ 110,250 | \$ 115,505 | \$ 121,028 | \$ 126,807 |
| Gymnastics Instructor | \$ 44,525 | \$ 46,539 | \$ 48,641 | \$ 50,812 | \$ 53,148 |
| Housing and Economic Development Manager | \$ 125,490 | | Open Range | | \$ 163,981 |
| Housing Manager | \$ 125,490 | | Open Range | | \$ 163,981 |
| Human Resources Director | \$ 165,347 | | Open Range | | \$ 234,259 |
| Human Resources Manager | \$ 130,350 | | Open Range | | \$ 175,695 |
| Human Resources Technician I | \$ 72,243 | \$ 75,661 | \$ 79,039 | \$ 82,895 | \$ 86,794 |
| Human Resources Technician II | \$ 79,467 | \$ 83,227 | \$ 86,943 | \$ 91,185 | \$ 95,473 |
| Information Technology Manager | \$ 130,350 | | Open Range | | \$ 175,695 |
| Information Technology Specialist I | \$ 77,815 | \$ 81,707 | \$ 85,792 | \$ 90,083 | \$ 94,588 |
| Information Technology Specialist II | \$ 86,460 | \$ 90,523 | \$ 94,781 | \$ 99,238 | \$ 103,997 |
| Internal Services Manager | \$ 130,350 | | Open Range | | \$ 175,695 |
| Junior Engineer | \$ 85,362 | \$ 89,630 | \$ 94,112 | \$ 98,818 | \$ 103,759 |
| Librarian I | \$ 74,587 | \$ 78,073 | \$ 81,736 | \$ 85,576 | \$ 89,602 |
| Librarian II | \$ 83,662 | \$ 87,678 | \$ 91,822 | \$ 96,153 | \$ 100,778 |
| Library and Community Services Director | \$ 161,038 | | Open Range | | \$ 234,259 |
| Library and Community Services Supervisor | \$ 96,464 | \$ 101,103 | \$ 105,920 | \$ 110,985 | \$ 116,285 |

Annual Salaries based on 2080 hours per year except where set by contract or noted

City of Menlo Park
Salary Schedule - effective 09/25/2022
PROPOSED

| | | | | | |
|--|-------------------|-------------------|-------------------|-------------------|-------------------|
| Library Assistant I | \$ 58,136 | \$ 60,769 | \$ 63,538 | \$ 66,544 | \$ 69,608 |
| Library Assistant II | \$ 63,538 | \$ 66,544 | \$ 69,515 | \$ 72,907 | \$ 76,336 |
| Library Assistant III | \$ 69,515 | \$ 72,907 | \$ 76,336 | \$ 79,871 | \$ 83,577 |
| Library Services Manager | \$ 130,350 | | Open Range | | \$ 175,695 |
| Literacy Program Manager | \$ 85,853 | \$ 89,891 | \$ 94,118 | \$ 98,630 | \$ 103,330 |
| Maintenance Worker I | \$ 63,538 | \$ 66,544 | \$ 69,515 | \$ 72,907 | \$ 76,336 |
| Maintenance Worker II | \$ 69,515 | \$ 72,907 | \$ 76,336 | \$ 79,871 | \$ 83,662 |
| Management Analyst I | \$ 92,043 | \$ 96,646 | \$ 101,479 | \$ 106,553 | \$ 111,881 |
| Management Analyst II | \$ 105,192 | \$ 110,250 | \$ 115,505 | \$ 121,028 | \$ 126,807 |
| Network Administrator | \$ 123,426 | \$ 129,334 | \$ 135,500 | \$ 142,046 | \$ 148,927 |
| Office Assistant | \$ 57,097 | \$ 59,701 | \$ 62,403 | \$ 65,360 | \$ 68,379 |
| Parking Enforcement Officer | \$ 63,538 | \$ 66,544 | \$ 69,515 | \$ 72,907 | \$ 76,336 |
| Permit Manager | \$ 119,656 | \$ 125,381 | \$ 131,382 | \$ 137,644 | \$ 144,295 |
| Permit Technician | \$ 74,567 | \$ 78,018 | \$ 81,665 | \$ 85,496 | \$ 89,513 |
| Plan Check Engineer | \$ 119,866 | \$ 125,604 | \$ 131,591 | \$ 137,949 | \$ 144,631 |
| Planning Manager | \$ 130,350 | | Open Range | | \$ 175,695 |
| Planning Technician | \$ 85,496 | \$ 89,513 | \$ 93,724 | \$ 98,131 | \$ 102,836 |
| Police Chief | \$ 178,414 | | Open Range | | \$ 257,685 |
| Police Commander | \$ 160,572 | | Open Range | | \$ 234,259 |
| Police Corporal (2080 hours) | \$ 115,707 | \$ 121,493 | \$ 127,567 | \$ 133,945 | \$ 140,643 |
| Police Corporal (2184 hours) | \$ 121,492 | \$ 127,567 | \$ 133,946 | \$ 140,643 | \$ 147,675 |
| Police Officer (2080 hours) | \$ 107,510 | \$ 112,884 | \$ 118,528 | \$ 124,455 | \$ 130,678 |
| Police Officer (2184 hours) | \$ 112,885 | \$ 118,529 | \$ 124,455 | \$ 130,678 | \$ 137,212 |
| Police Records Specialist | \$ 69,515 | \$ 72,907 | \$ 76,336 | \$ 79,871 | \$ 83,662 |
| Police Recruit | n/a | | Hourly Rate | | \$ 87,083 |
| Police Sergeant (2080 hours) | \$ 133,068 | \$ 139,721 | \$ 146,707 | \$ 154,042 | \$ 161,744 |
| Police Sergeant (2184 hours) | \$ 139,721 | \$ 146,707 | \$ 154,042 | \$ 161,744 | \$ 169,832 |
| Principal Planner | \$ 127,020 | \$ 134,973 | \$ 141,433 | \$ 148,174 | \$ 153,174 |
| Program Aide/Driver | \$ 39,920 | \$ 41,726 | \$ 43,614 | \$ 45,587 | \$ 47,629 |
| Program Assistant | \$ 56,871 | \$ 59,463 | \$ 62,154 | \$ 65,100 | \$ 68,106 |
| Project Manager | \$ 112,205 | \$ 117,576 | \$ 123,182 | \$ 129,133 | \$ 135,388 |
| Property and Court Specialist | \$ 72,907 | \$ 76,336 | \$ 79,871 | \$ 83,662 | \$ 87,678 |
| Public Engagement Manager | \$ 130,350 | | Open Range | | \$ 175,695 |
| Public Works Director | \$ 169,611 | | Open Range | | \$ 234,259 |
| Public Works Superintendent | \$ 128,081 | | Open Range | | \$ 175,695 |
| Public Works Supervisor - Facilities | \$ 106,541 | \$ 111,649 | \$ 116,969 | \$ 122,558 | \$ 128,421 |
| Public Works Supervisor - Fleet | \$ 108,236 | \$ 113,425 | \$ 118,829 | \$ 124,506 | \$ 130,463 |
| Public Works Supervisor - Park | \$ 100,707 | \$ 105,534 | \$ 110,563 | \$ 115,845 | \$ 121,388 |
| Public Works Supervisor - Streets | \$ 100,707 | \$ 105,534 | \$ 110,563 | \$ 115,845 | \$ 121,388 |
| Public Works Supervisor - Trees | \$ 100,707 | \$ 105,534 | \$ 110,563 | \$ 115,845 | \$ 121,388 |
| Recreation Coordinator | \$ 74,828 | \$ 78,324 | \$ 82,000 | \$ 85,853 | \$ 89,891 |
| Revenue and Claims Manager | \$ 105,192 | \$ 110,250 | \$ 115,505 | \$ 121,028 | \$ 126,807 |
| Senior Accountant | \$ 110,509 | \$ 115,734 | \$ 121,193 | \$ 127,022 | \$ 133,075 |
| Senior Accounting Assistant | \$ 74,991 | \$ 78,495 | \$ 82,127 | \$ 85,965 | \$ 89,999 |
| Senior Building Inspector | \$ 114,394 | \$ 119,866 | \$ 125,604 | \$ 131,591 | \$ 137,949 |
| Senior Civil Engineer | \$ 130,770 | \$ 137,087 | \$ 143,729 | \$ 150,693 | \$ 158,036 |
| Senior Communications Dispatcher | \$ 97,500 | \$ 102,189 | \$ 107,059 | \$ 112,178 | \$ 117,533 |
| Senior Construction Inspector | \$ 105,769 | \$ 110,856 | \$ 116,139 | \$ 121,707 | \$ 127,793 |
| Senior Engineering Technician | \$ 96,413 | \$ 100,962 | \$ 105,817 | \$ 110,859 | \$ 116,160 |
| Senior Equipment Mechanic | \$ 87,868 | \$ 92,155 | \$ 96,489 | \$ 100,958 | \$ 105,749 |
| Senior Facilities Maintenance Technician | \$ 79,862 | \$ 83,662 | \$ 87,678 | \$ 91,822 | \$ 96,153 |
| Senior GIS Analyst | \$ 118,340 | \$ 123,962 | \$ 129,850 | \$ 136,083 | \$ 142,657 |
| Senior Human Resources Technician | \$ 87,414 | \$ 91,550 | \$ 95,637 | \$ 100,303 | \$ 105,021 |
| Senior Library Assistant | \$ 76,467 | \$ 80,198 | \$ 83,969 | \$ 87,858 | \$ 91,935 |
| Senior Maintenance Worker | \$ 79,862 | \$ 83,662 | \$ 87,678 | \$ 91,822 | \$ 96,153 |
| Senior Management Analyst | \$ 118,340 | \$ 123,962 | \$ 129,850 | \$ 136,083 | \$ 142,657 |
| Senior Office Assistant | \$ 62,403 | \$ 65,360 | \$ 68,379 | \$ 71,573 | \$ 74,885 |
| Senior Planner | \$ 115,473 | \$ 120,998 | \$ 126,789 | \$ 132,833 | \$ 139,250 |
| Senior Police Records Specialist | \$ 72,907 | \$ 76,336 | \$ 79,871 | \$ 83,662 | \$ 87,678 |
| Senior Program Assistant | \$ 69,066 | \$ 72,294 | \$ 75,687 | \$ 79,242 | \$ 82,971 |
| Senior Project Manager | \$ 123,426 | \$ 129,334 | \$ 135,500 | \$ 142,046 | \$ 148,927 |
| Senior Sustainability Specialist | \$ 86,614 | \$ 90,757 | \$ 95,101 | \$ 99,635 | \$ 104,448 |
| Senior Transportation Engineer | \$ 130,770 | \$ 137,087 | \$ 143,729 | \$ 150,693 | \$ 158,036 |
| Senior Transportation Planner | \$ 115,473 | \$ 120,998 | \$ 126,789 | \$ 132,833 | \$ 139,250 |
| Senior Water System Operator | \$ 81,945 | \$ 85,738 | \$ 89,745 | \$ 93,956 | \$ 98,369 |
| Sustainability Manager | \$ 125,490 | | Open Range | | \$ 163,981 |
| Sustainability Specialist | \$ 74,587 | \$ 78,073 | \$ 81,736 | \$ 85,576 | \$ 89,602 |
| Systems Administrator | \$ 118,340 | \$ 123,962 | \$ 129,850 | \$ 136,083 | \$ 142,657 |
| Transportation Demand Management Coord. | \$ 98,314 | \$ 102,997 | \$ 107,919 | \$ 113,082 | \$ 118,494 |
| Transportation Director | \$ 169,611 | | Open Range | | \$ 234,259 |
| Transportation Manager | \$ 130,350 | | Open Range | | \$ 175,695 |
| Water Quality Specialist | \$ 83,084 | \$ 86,992 | \$ 91,083 | \$ 95,450 | \$ 99,997 |
| Water System Operator I | \$ 68,090 | \$ 71,141 | \$ 74,296 | \$ 77,967 | \$ 81,596 |
| Water System Operator II | \$ 74,495 | \$ 77,944 | \$ 81,586 | \$ 85,414 | \$ 89,427 |



STAFF REPORT

City Council

Meeting Date: 9/13/2022
Staff Report Number: 22-175-CC

Informational Item: City Council agenda topics: September – October 20, 2022

Recommendation

The purpose of this informational item is to provide the City Council and members of the public access to the anticipated agenda items that will be presented to the City Council. The mayor and city manager set the City Council agenda so there is no action required of the City Council as a result of this informational item.

Policy Issues

In accordance with the City Council procedures manual, the mayor and city manager set the agenda for City Council meetings.

Analysis

In an effort to provide greater access to the City Council's future agenda items, staff has compiled a listing of anticipated agenda items, Attachment A, through October 20, 2022. The topics are arranged by department to help identify the work group most impacted by the agenda item.

Specific dates are not provided in the attachment due to a number of factors that influence the City Council agenda preparation process. In their agenda management, the mayor and city manager strive to compile an agenda that is most responsive to the City Council's adopted priorities and work plan while also balancing the business needs of the organization. Certain agenda items, such as appeals or State mandated reporting, must be scheduled by a certain date to ensure compliance. In addition, the meeting agendas are managed to allow the greatest opportunity for public input while also allowing the meeting to conclude around 11 p.m. Every effort is made to avoid scheduling two matters that may be contentious to allow the City Council sufficient time to fully discuss the matter before the City Council.

Public Notice

Public notification was achieved by posting the agenda, with the agenda items being listed, at least 72 hours prior to the meeting.

Attachments

A. City Council agenda topics: City Council agenda topics: September – October 20, 2022

Report prepared by:

Judi A. Herren, Assistant to the City Manager/City Clerk

Tentative City Council Agenda

| # | Title | Department | Item type | City Council action |
|----|---|------------|---------------|----------------------------------|
| 1 | Quarterly Personnel Activity Report | ASD | Informational | No action |
| 2 | Approve funding for 335 Pierce Road (predevelopment CLT, loan authorization docs) | CDD | Regular | Approve |
| 3 | Authorize the city manager to enter into a contract with ICF Jones and Stokes Inc. to prepare an environmental impact report and housing needs assessment for the proposed master plan project at 333 Ravenswood Avenue (Parkline) | CDD | Consent | Contract award or amend |
| 4 | Housing Element Update water supply assessment | CDD | Regular | Adopt resolution |
| 5 | Adopt a resolution updating the City's conflict of interest code | CMO | Consent | Adopt resolution |
| 6 | Adopt Resolution to continue conducting the City's Council and advisory body meetings remotely due to health and safety concerns for the public | CMO | Consent | Adopt resolution |
| 7 | Authorize Mayor to send letter on Stanford Community Plan Update | CMO | Consent | Approve |
| 8 | Authorize the city manager to execute an agreement with MPCSD and MPAEF and approve a budget amendment | CMO | Regular | Approve, Contract award or amend |
| 9 | Authorize the Mayor to sign the City's response to the San Mateo County's grand jury report: "Waiter! There's a Car in My Soup!" | CMO | Consent | Approve |
| 10 | BlocPower: prevailing wage | CMO | Informational | Decide, Direction to staff |
| 11 | Certificate of Recognition: Olivia Hom, Menlo Park Sister Cities Young Artists and Authors Showcase winner | CMO | Proclamation | No action |
| 12 | Study Session on Leaf Blower Ban | CMO | Study Session | Direction to staff |
| 13 | Update advisory body policy with Complete Streets Commission start time and other necessary updates | CMO | Consent | Adopt resolution |
| 14 | Second reading adopt: Amend MPMC filling vacancy on City Council | CMO, CAO | Consent | Adopt ordinance |
| 15 | Reso adoption for City Council vacancies | CMO, CAO | Consent | Adopt resolution |
| 16 | Approve the Parks and Recreation Commission work plan | LCS | Consent | Approve |
| 17 | Authorize the City Manager to issue a request for proposals for an aquatics operator at Burgess Pool and Menlo Park Community Campus pool | LCS | Regular | Approve |
| 18 | Commemorative park amenities policy | LCS | Informational | Receive and file |
| 19 | Direction for city hosted events and observances including events based on holidays of religious origin | LCS | Regular | Direction to staff |
| 20 | Police department quarterly update | PD | Informational | Info from staff |
| 21 | Adopt resolution for SMCTA bike/ped program grants | PW | Consent | Adopt resolution |
| 22 | Authorize an agreement with consultant for local road safety plan | PW | Consent | Approve |
| 23 | Authorize the City Manager to enter into an agreement with the City of Redwood City for annual maintenance of Atherton Channel | PW | Consent | Contract award or amend |
| 24 | Authorize the city manager to execute an agreement with the West Bay Sanitary District regarding the provision of recycled water service within Menlo Park Municipal Water Bayfront Area, and other customers within the Recycled Water Purveyor Boundary | PW | Consent | Contract award or amend |
| 25 | Award a construction contract to Blue Flame Crew West, LLC for the Bedwell Bayfront Park Landfill Leachate and Gas Collection Systems Improvement Project | PW | Consent | Contract award or amend |

Tentative City Council Agenda

| <i>#</i> | <i>Title</i> | <i>Department</i> | <i>Item type</i> | <i>City Council action</i> |
|----------|---|-------------------|------------------|----------------------------|
| 26 | Award contracts for the FY22-23 vehicle purchase | PW | Regular | Approve |
| 27 | Drought update | PW | Informational | No action |
| 28 | Local Hazard Mitigation Plan Update | PW | Informational | No action |
| 29 | Provide direction on procedure for installing all way stop signs and installation of all way stops at three locations | PW | Regular | Approve |
| 30 | Provide direction on the continued use of level of service analysis in traffic impact analysis | PW | Study Session | Direction to staff |
| 31 | Update on Caltrain grade separation project | PW | Informational | Info from staff |
| 32 | Special Joint MPFPD Meeting | Various | | |

RESOLUTION TO ABANDON PUBLIC UTILITY EASEMENT

248 Oakhurst Pl, Menlo Park

PROJECT BACKGROUND

- Summary Vacation – 2 step process
 - Planning Commission
 - City Council
- On July 25, 2022, Planning Commission adopted Resolution No. 2022-13 confirming that proposed abandonment was consistent with general plan and recommending approval of abandonment.



PLAN SHEET

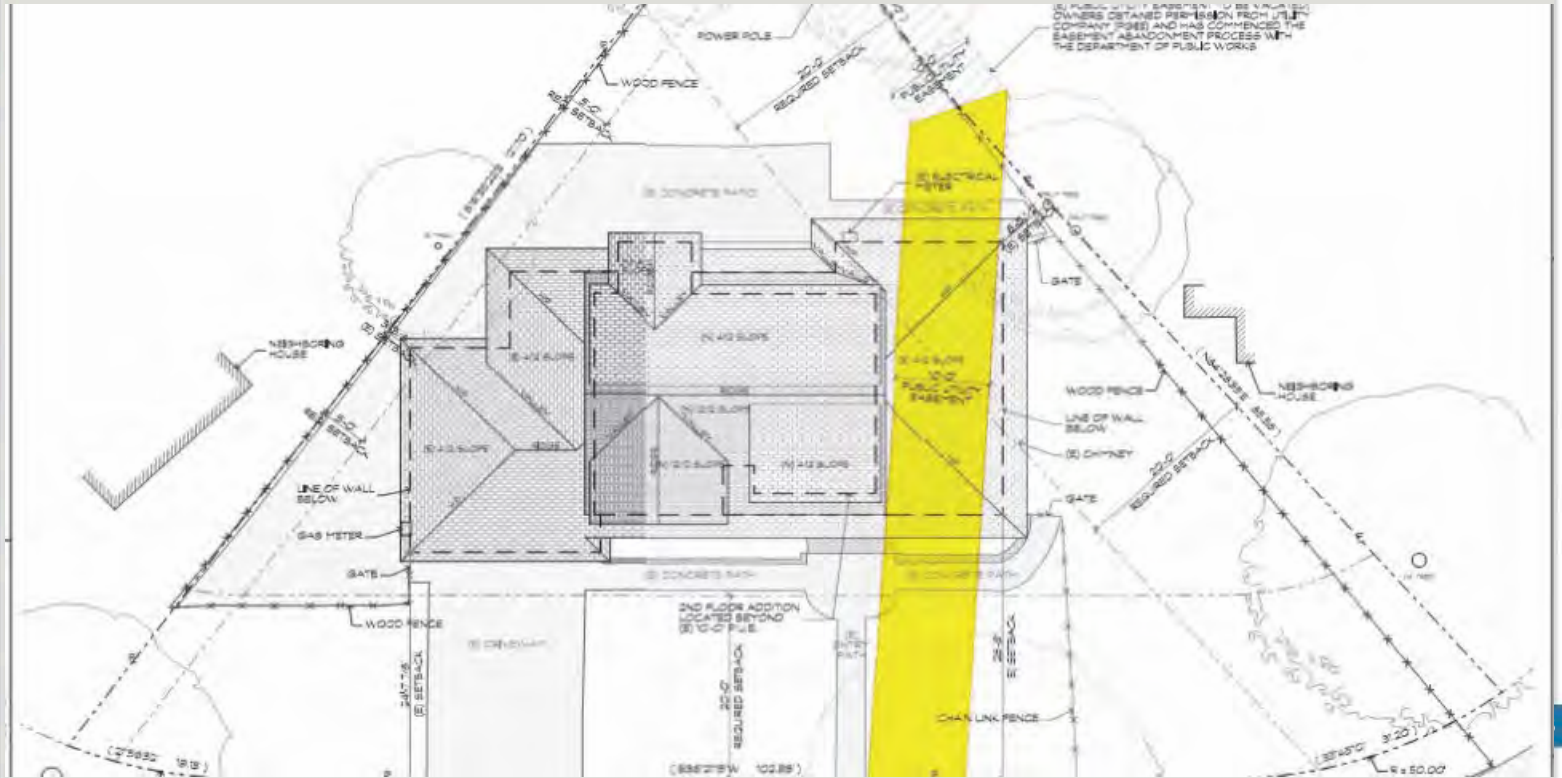

RECOMMENDED ACTION

- Adopt resolution ordering the vacation of the 10-foot-wide Public Utility Easement running through a portion of the existing structure at 248 Oakhurst Place.



THANK YOU



MIDDLE AVENUE COMPLETE STREETS PROJECT

City Council | September 13, 2022





AGENDA

- Project goals
- Background
- Public outreach summary
- Conceptual design options and recommendations
 1. Bikeway design
 2. Traffic calming measures
 3. Intersection treatments
- City Council Action and Next steps



PROJECT GOALS

- Enhance bicyclist and pedestrian visibility and improve safety of all users
- Provide safe and comfortable cycling and pedestrian infrastructure and encourage sustainable mode of transportation
- Increase accessibility of the corridor by supporting improvements related to Middle Plaza and ongoing study of the grade-separated pedestrian and bicycle crossing



BACKGROUND



- 65' City right of way
- 42' wide curb to curb
- Edge lines with parallel parking
- No separation for bicyclists
- Speed limit varies – 25 to 30 MPH + new 15 MPH school zones



PUBLIC OUTREACH





PUBLIC OUTREACH EFFORTS

- **Publicity**
 - Over 2,000 postcards to local businesses and residences
 - Changeable Message Signs
 - Social media, website, press release

- **Public meetings – March 3, 2022**
 - In-person at Nealon Park tennis court
 - Virtually via Zoom
 - About 100 total participants

- **Online survey**
 - Over 600 respondents
 - 10% live on Middle Avenue
 - 80% live nearby
 - 10% live elsewhere in the City

- **Councilmember led outreach events**



In person outreach



PUBLIC MEETING FINDINGS

- Overall support for bicycle and pedestrian improvements
- Concerns about bicycling safety, especially for children
- Some concerns expressed about removal of street parking
- Concerns about speeding vehicles and the lack of traffic calming to slow down vehicles
- Concerns about larger trucks traveling on Middle Avenue



ONLINE SURVEY

BIKE LANE/PARKING REMOVAL PREFERENCES

Remove both sides
 Remove one side
 Do not remove or Partial removal

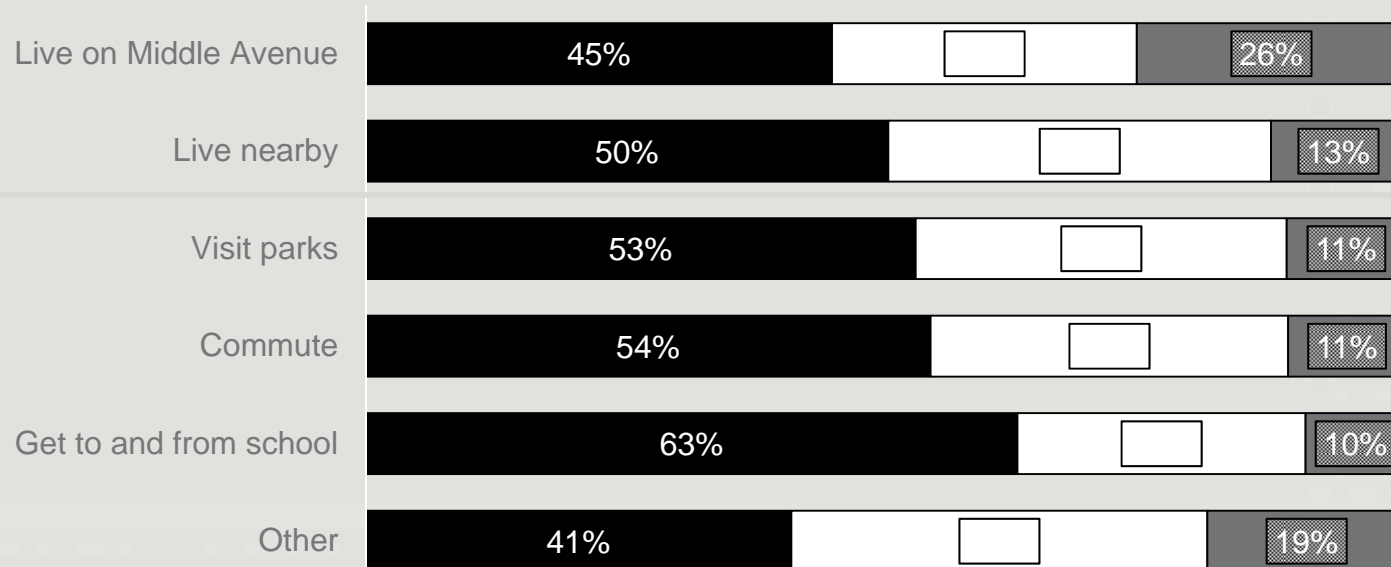



**CONCEPTUAL DESIGN
OPTIONS AND
RECOMMENDATIONS**





CONCEPTUAL DESIGN ELEMENTS

- Corridor traffic calming
- Bicycle facility / parking removal
- Intersection improvements (El Camino Real, University Drive, Olive Street)
- Others:
 - Safeway and Shell gas station driveways
 - Blake Street temporary closure
 - Sidewalk gap closure





CORRIDOR TRAFFIC CALMING



- Traffic calming tools
 - Raised crosswalks
 - Speed humps
 - Flashing beacons (RRFBs)
 - Stop sign
 - Bulb outs (in parking lane)
- CSC accepted staff recommendations for placement of specific elements





BICYCLE FACILITY OPTIONS



Existing

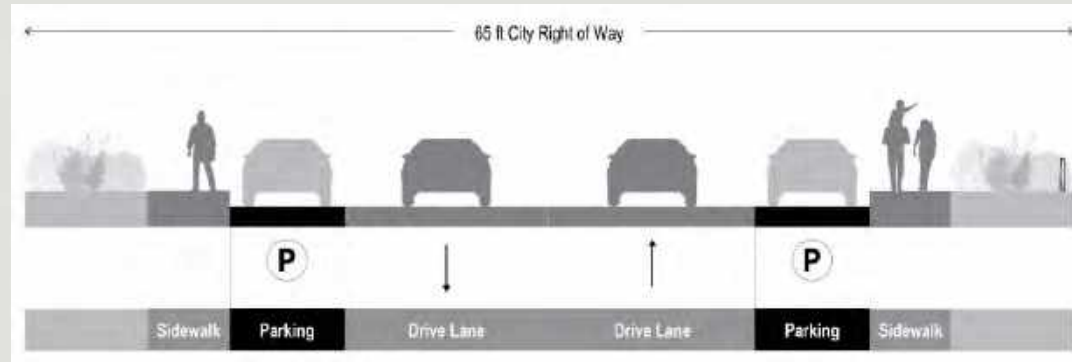

No Parking

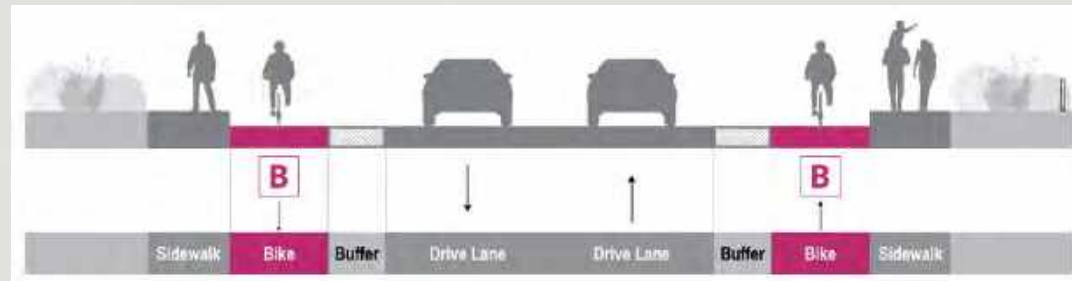

Parking One Side

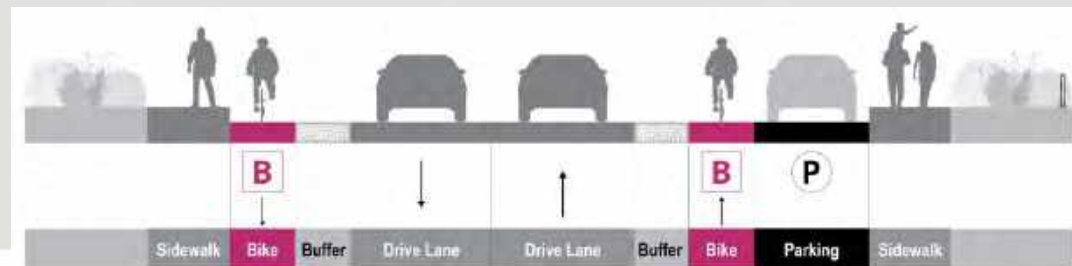



BICYCLE FACILITY OPTIONS – EXAMPLES





TRAFFIC CALMING AND BIKEWAY IMPROVEMENTS

University Dr. to El Camino Real

Complete Streets Commission recommendation - Remove Parking from one side

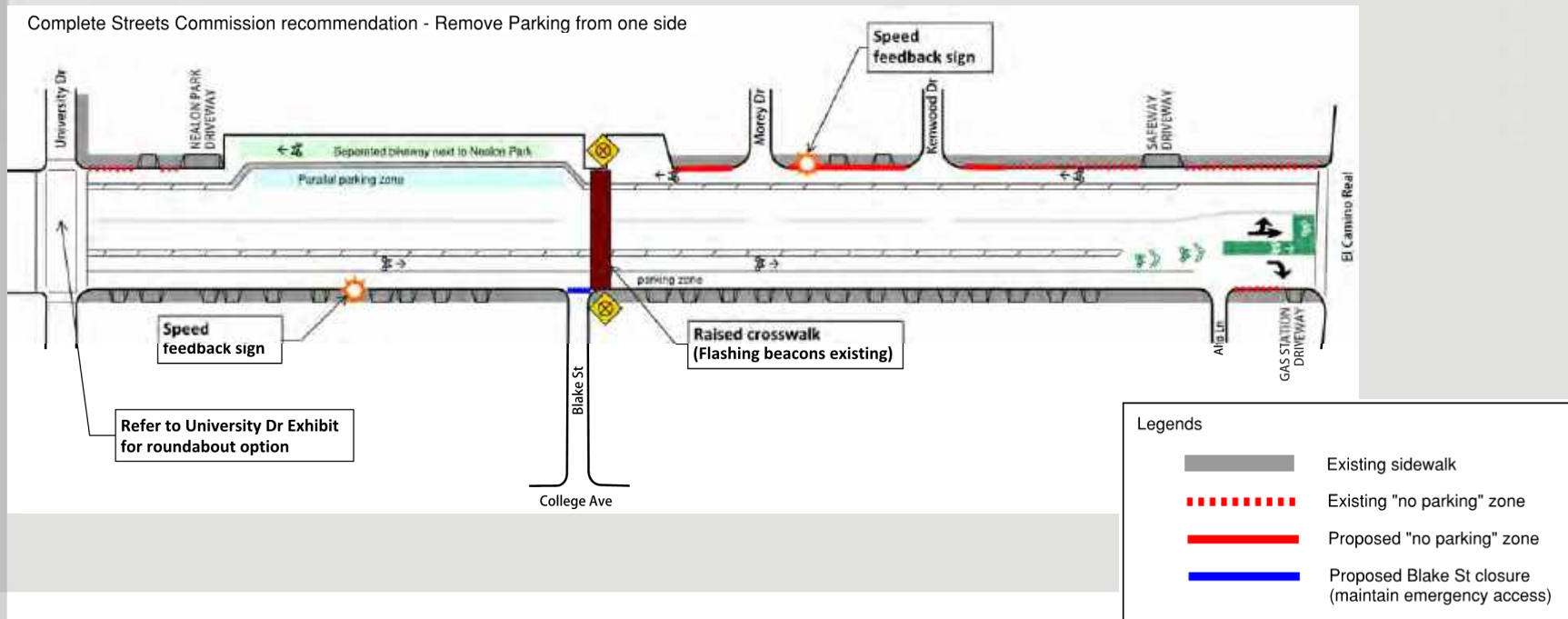



TRAFFIC CALMING AND BIKEWAY IMPROVEMENTS

San Mateo Dr. to University Dr.

Complete Streets Commission recommendation - Remove Parking from one side

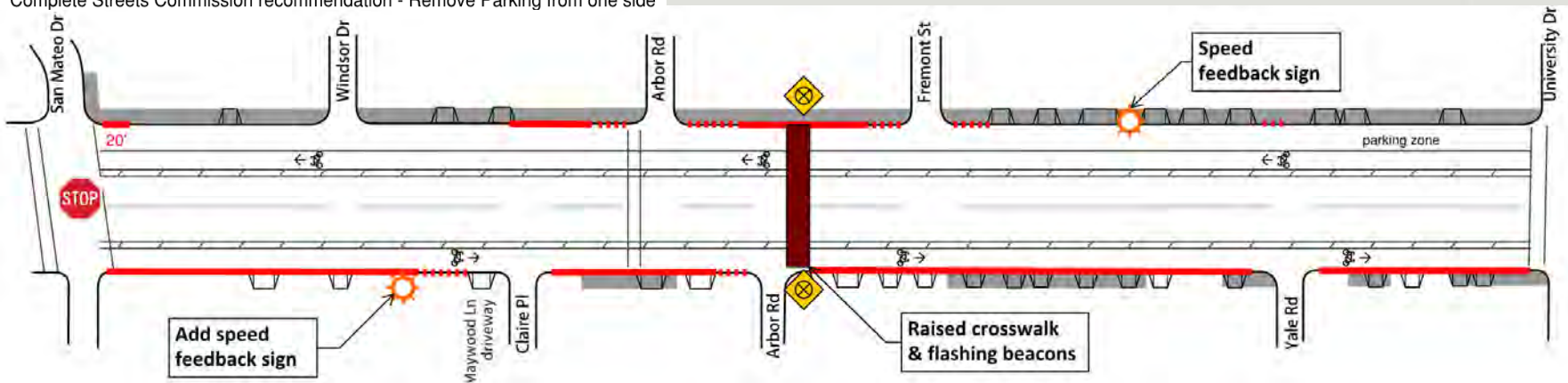

| Legends | | | |
|---------|----------------------------|--|----------------------------|
| | Existing sidewalk | | Proposed "stop" sign |
| | Existing "no parking" zone | | Proposed "no parking" zone |



TRAFFIC CALMING AND BIKEWAY IMPROVEMENTS

Olive St. to San Mateo Dr.

Complete Streets Commission recommendation - Remove Parking from one side

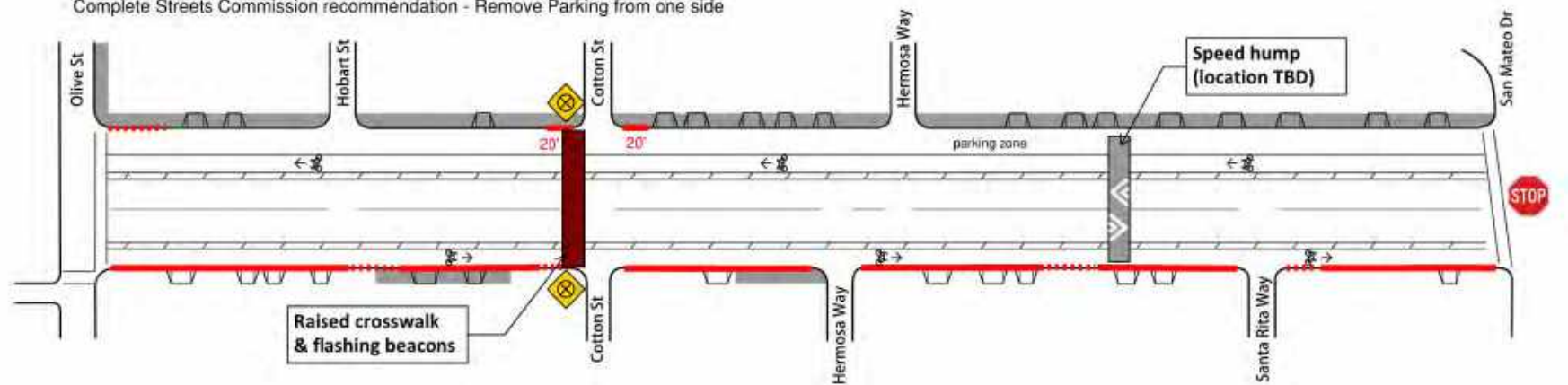

| Legends | | | |
|---|----------------------------|---|----------------------------|
|  | Existing sidewalk |  | Proposed "stop" sign |
|  | Existing "no parking" zone |  | Proposed "no parking" zone |

EL CAMINO REAL CSC RECOMMENDATIONS



- Pursue dedicated intersection
 - Some right-of-way acquisition may be needed
- Pursue short/mid-term signal improvements
 - Leading pedestrian interval
 - No right turn on red (blank out signs during start of pedestrian crossing phase)
 - Protected left turns
 - Bicycle signal



UNIVERSITY DRIVE AND OLIVE STREET CSC RECOMMENDATIONS



- Remove turn pockets at University Dr and Olive St
 - Removing right-turn pockets is not expected to create additional congestion
- Pursue a pilot mini-roundabout at University Dr
 - Include education and encouragement as part of pilot





SAFeway AND SHELL DRIVEWAY CSC RECOMMENDATIONS

- Ongoing monitoring of driveways at both properties
- Pursue conversation with Shell gas station owner about closing one access point from Middle Avenue (one would remain via Alto Lane)
- No action at Safeway driveways

Recommended closure

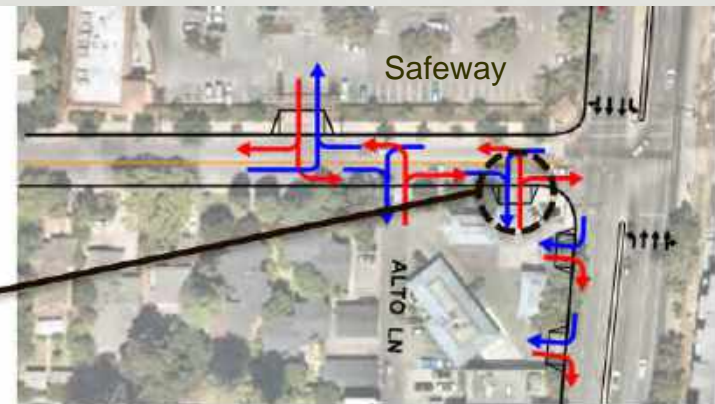

Existing Turning Movements



BLAKE STREET TEMPORARY CLOSURE

- CSC supported temporary closure of Blake Street at Middle Avenue
- Staff will coordinate with residents and install a bollard-based closure



CLOVER LN CLOSURE (EXAMPLE)



SIDEWALK GAP CLOSURE

- About 3,000 feet of sidewalk gap on south side of Middle Avenue
- Cost estimate to install concrete sidewalks – \$4 million
- CSC recommended pursuing sidewalk closure
- Staff recommends adding to 5-year CIP program





ACTION REQUESTED TONIGHT

- Provide direction on project recommendations
 - Traffic calming at regular intervals
 - Parking on one side, buffered bikeways on both sides
 - Pursue closure of Shell gas station driveway
 - Temporary closure of Blake Street at Middle Avenue
 - Add sidewalk on south side to 5-year CIP
- Adopt a resolution to:
 - Remove parking on one side of Middle Avenue and up to 24 spaces on the other side
 - Install an all way stop at Middle Avenue and San Mateo Drive
 - Authorize a temporary closure of Blake Street at Middle Avenue



NEXT STEPS

- El Camino to University
 - Staff to provide direction to Stanford University to complete bikeway elements
- University to Olive
 - Staff to commence design for preferred concept
 - Staff to pursue grant opportunities to support implementation
- Blake Street temporary closure
 - Staff to design and install
- Evaluation/Data collection
 - Staff to collect parking counts on Sunday near the New Community Church
 - Staff to collect data on parallel and intersecting streets using existing data collection contract



THANK YOU



MENLO PARK COMMUNITY CAMPUS PROJECT UPDATES AND SURVEY RESULTS

City Council – September 13, 2022



MPCC - Project updates

- Upcoming City Council items
- Environmental sustainability features
- Furnishing layouts
- Construction tours
- Other updates
- Resident survey – recreation and community programs
- Programming considerations
- Next steps





Upcoming City Council items

- October 11 – Authorize staff to issue a RFP for an aquatics operator at Burgess Pool and the new MPCC Pool
- November/December – Provide direction to update City Council Policy CC-86-0001, “Naming and/or changing the name of facilities” (1986)
- December/January – Award of contract and budget authorization for procurement of MPCC furnishings and nonfixed equipment
- January/February – Preliminary options for parking management plan
- January/February – Preliminary considerations for MPCC staffing and operations



Environmental sustainability features

- The MPCC project is being designed to LEED Platinum standards for environmental sustainability
- Library Commission and Parks and Recreation Commission June 22 joint study session included a presentation by project architects Hart Howerton about the MPCC project's many environmental sustainability features
- Attachment B to the staff report.

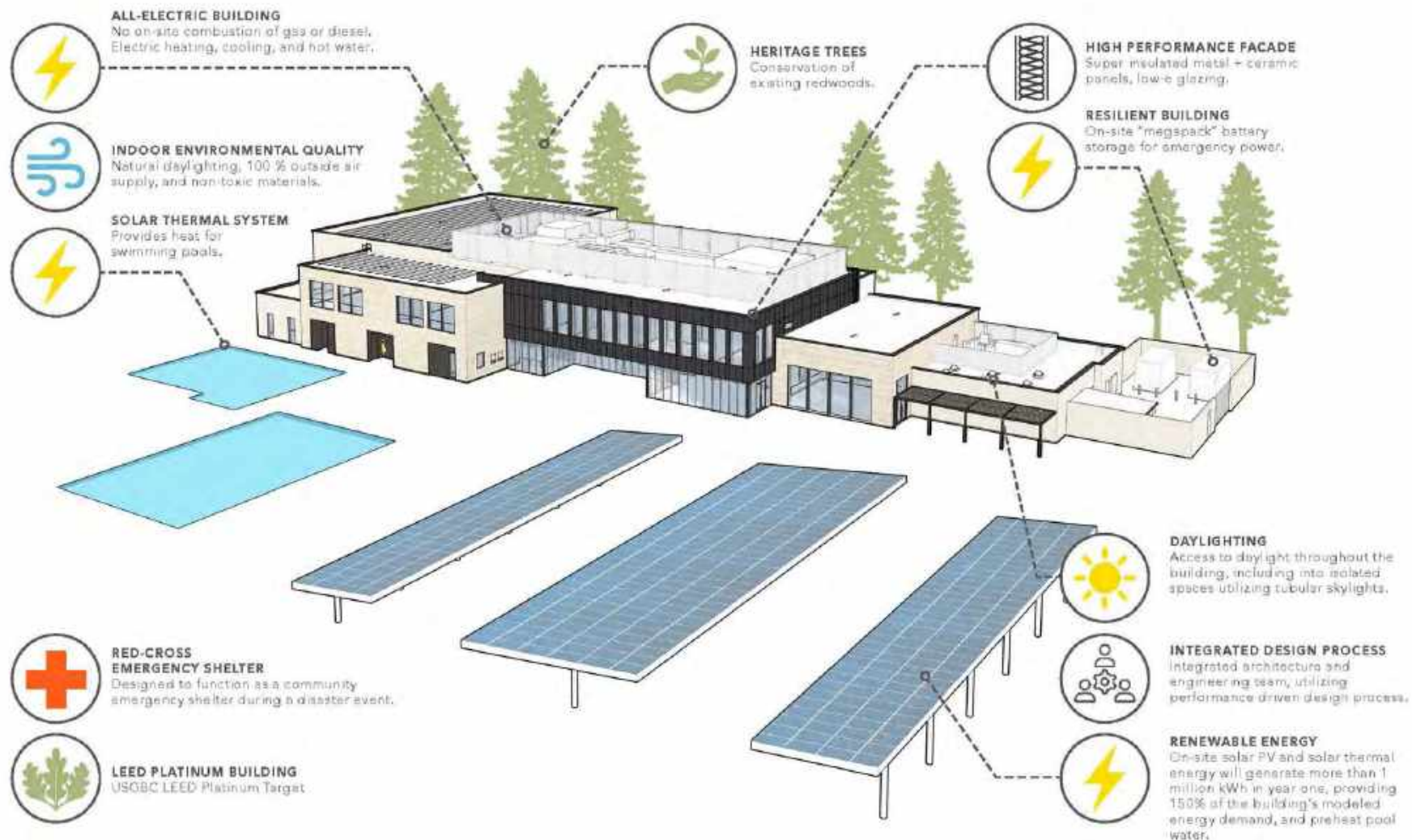

A Sustainable and Resilient Community Campus

HART HOWERTON



MPCC furnishing layouts

- The MPCC subcommittee and working group requested additional visual aids that show the proposed furnishings in layout.
- City staff worked with the architects to develop visualizations that show the proposed furnishings to scale in an engaging “3-D” format
- Attachment C to the staff report.



1 Senior Lounge 1

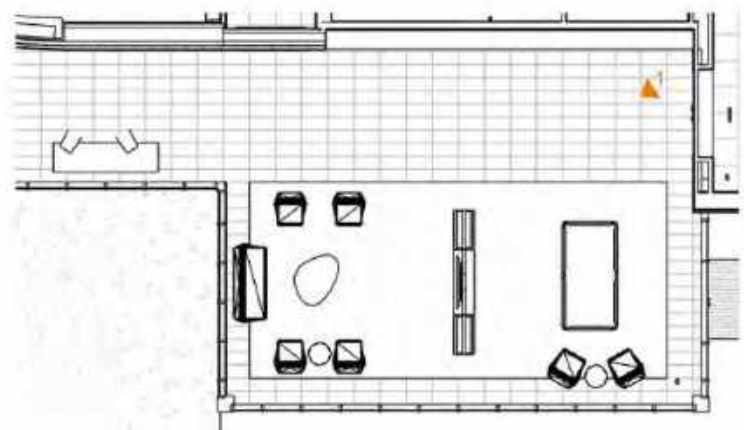



SENIOR LOUNGE
FIRST FLOOR



2 Childrens Library 1



3 Childrens Library 2





CHILDREN'S LIBRARY
FIRST FLOOR



4 Makerspace 1



5 Makerspace 2





MAKERSPACE
SECOND FLOOR

FIRST FLOOR

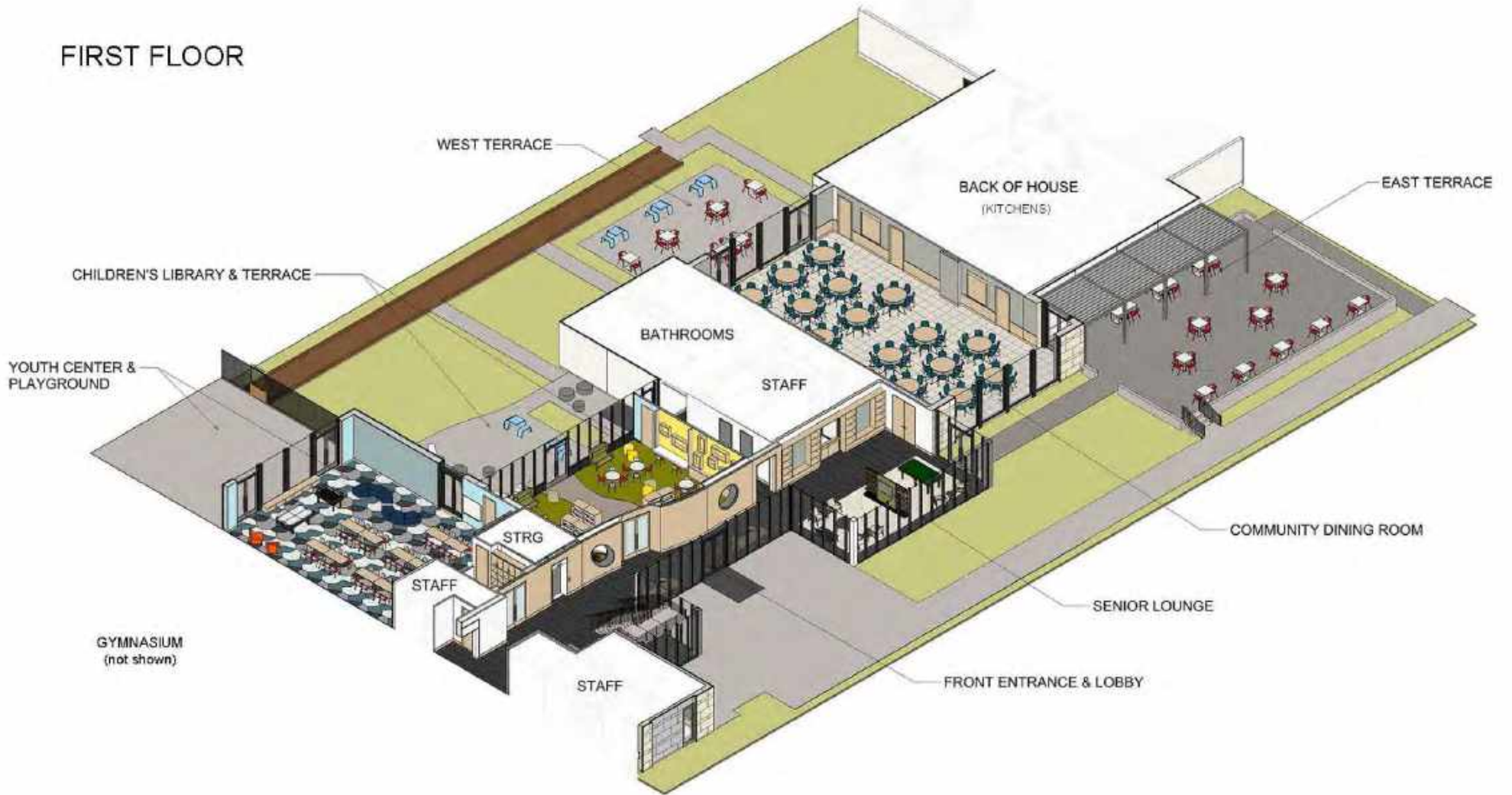

SECOND FLOOR

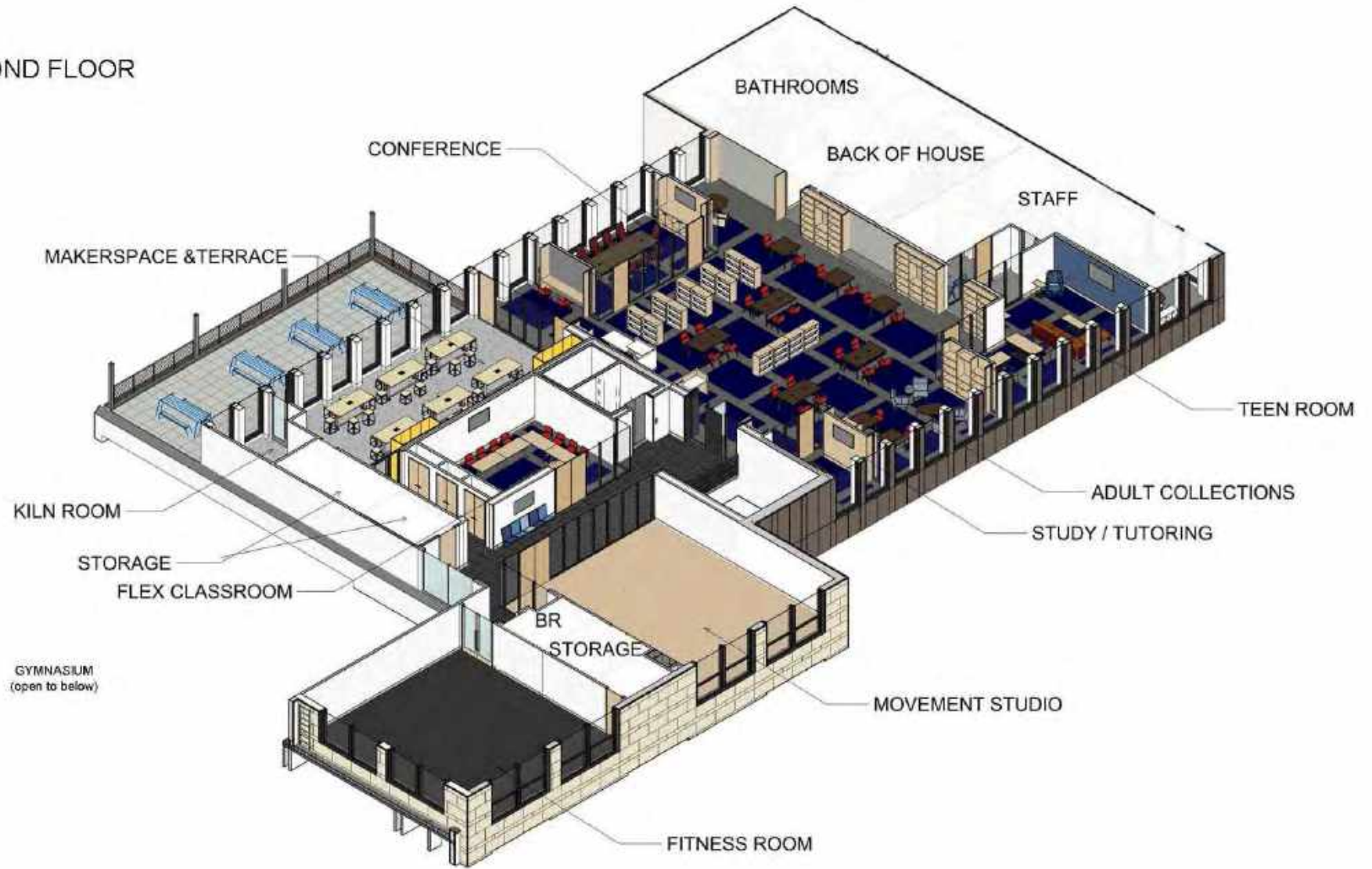



Construction tours

Upcoming tours of the MPCC construction site to provide Menlo Park residents, especially from the Belle Haven neighborhood, the opportunity to observe and experience the project while it is under construction.

- Friday, October 21 – This tour will feature the interior stairs and passageways and a walkthrough of the structure
- Friday, January 6 – Tour of the swimming pools and splash pad under construction, in addition to a walkthrough of the main structure
- Friday, March 10 – Focus on the gymnasium and other major interior rooms, in addition to a walkthrough of the structure



Other updates

The staff report contains additional brief updates:

- Project timeline
- Beechwood school temporary entrance change
- Parking management plan
- Pool heat pumps and exception to noise ordinance.





Survey results

- Resident survey - recreation and community programs
- Developed with input from the MPCC Subcommittee and working group, Parks and Recreation Commission, Library Commission, and City Council
- Survey opened June 13, closed August 10
- Distributed in paper and electronic formats; in English and Spanish
- 900+ respondents
- Complete survey results - Attachment A to the report

1. What neighborhood of Menlo Park do you live in now?

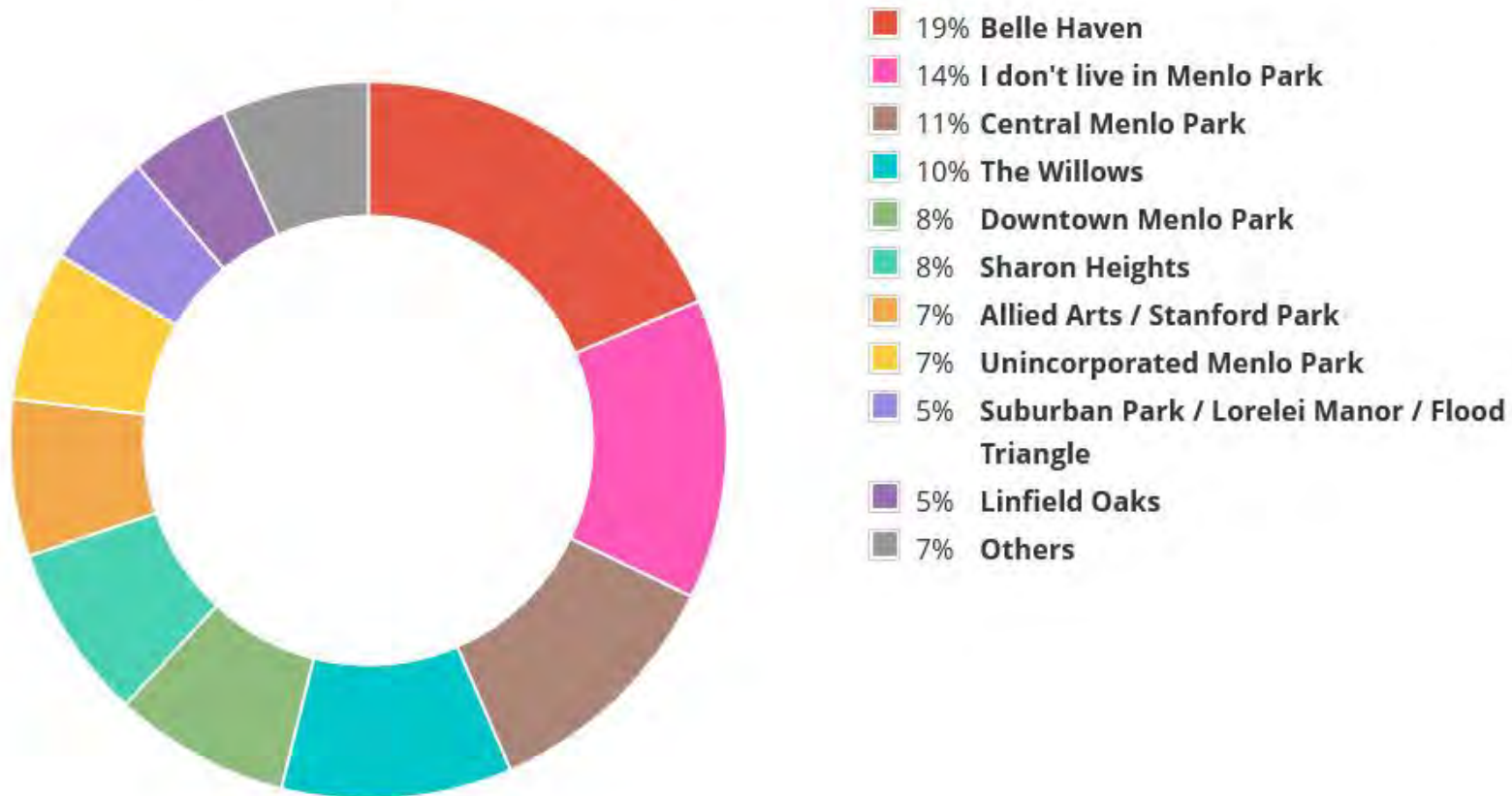

932 respondents

2. How long have you lived in Menlo Park?

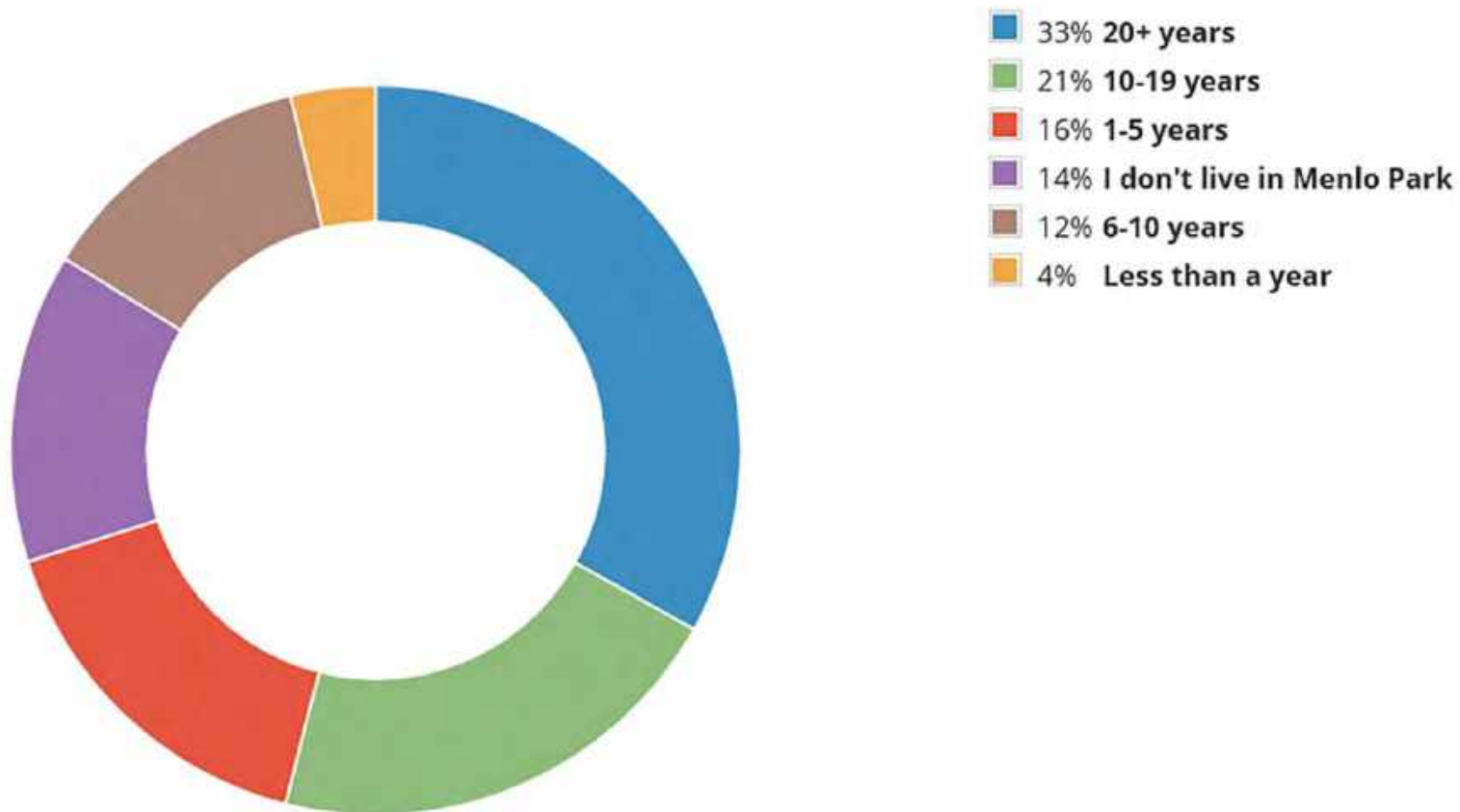

932 respondents

Q5. How important are the following community programs and classes?

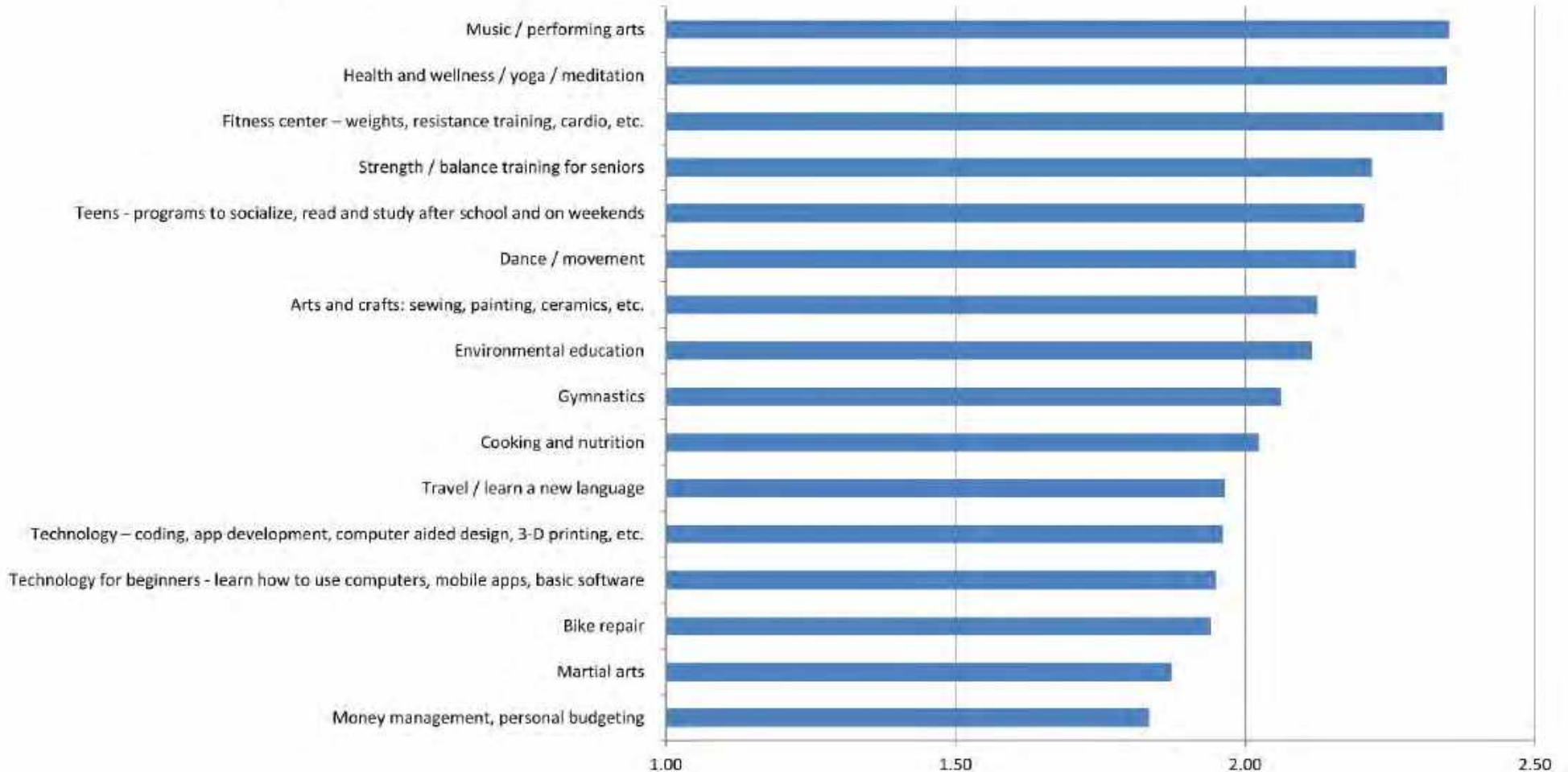

Chart shows average relative importance rated by survey respondents. Respondents rated each item as either "not at all important," "somewhat important," or "very important." Items rated "not important" are assigned a value of 1; "somewhat important" a value of 2; and "very important" a value of 3. The chart shows the average value of all ratings for each item. Higher average ratings indicate higher relative importance to the survey respondents.

Q6. For community programs and classes, how important are the following items?

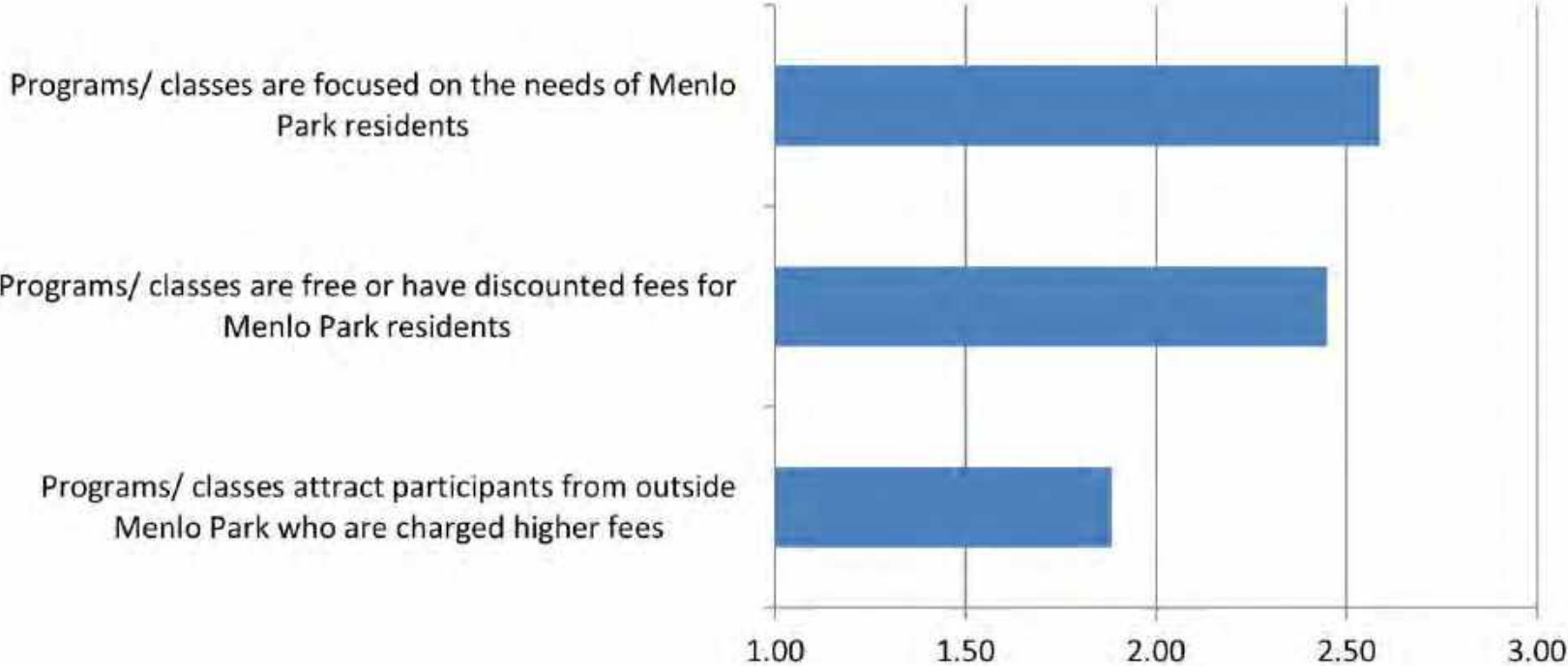

Chart shows average relative importance rated by survey respondents. Respondents rated each item as either "not at all important," "somewhat important," or "very important." Items rated "not important" are assigned a value of 1; "somewhat important" a value of 2; and "very important" a value of 3. The chart shows the average value of all ratings for each item. Higher average ratings indicate higher relative importance to the survey respondents.

Q12. How important are the following athletic programs?

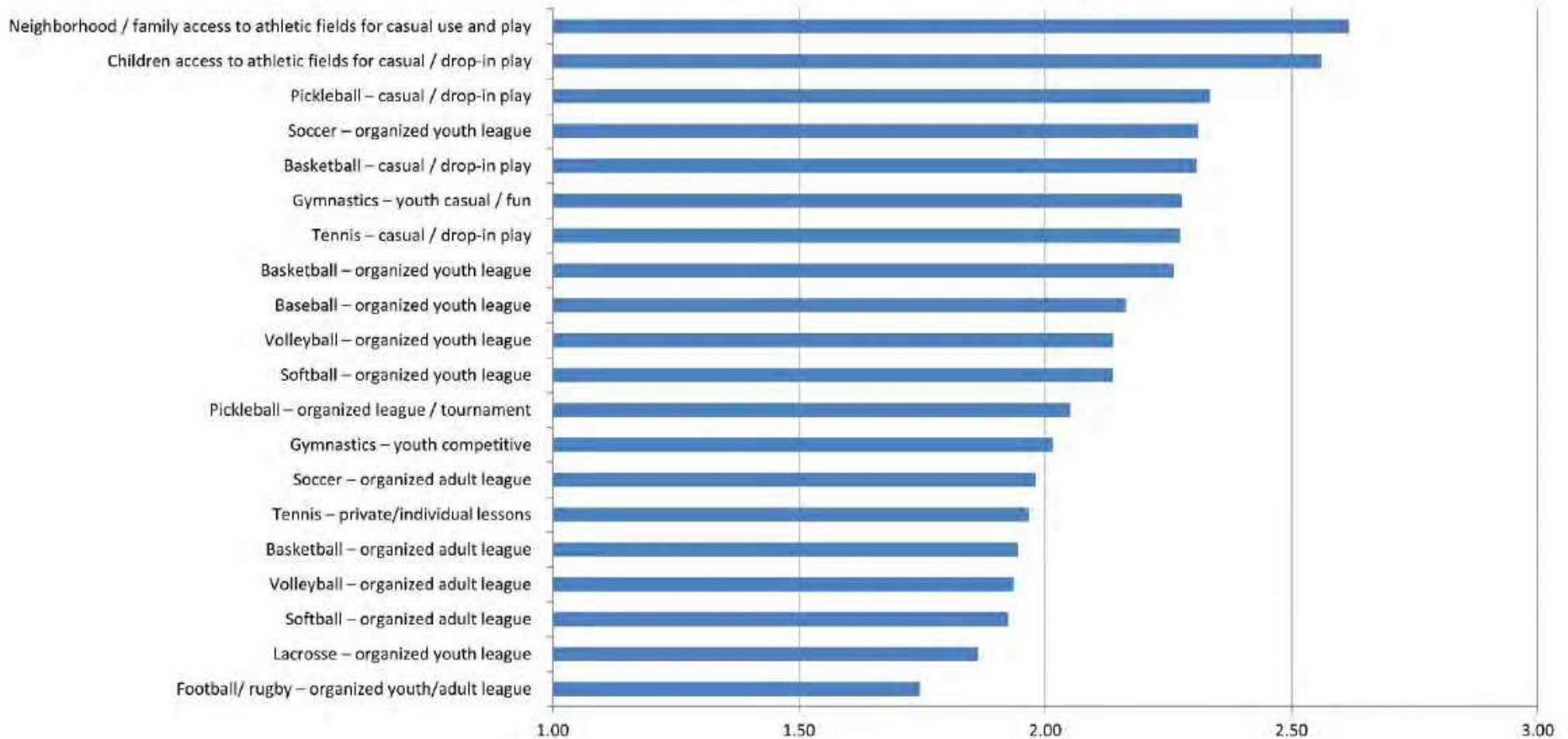

Chart shows average relative importance rated by survey respondents. Respondents rated each item as either "not at all important," "somewhat important," or "very important." Items rated "not important" are assigned a value of 1; "somewhat important" a value of 2; and "very important" a value of 3. The chart shows the average value of all ratings for each item. Higher average ratings indicate higher relative importance to the survey respondents.

Q13. For athletic programs, how important are the following items?

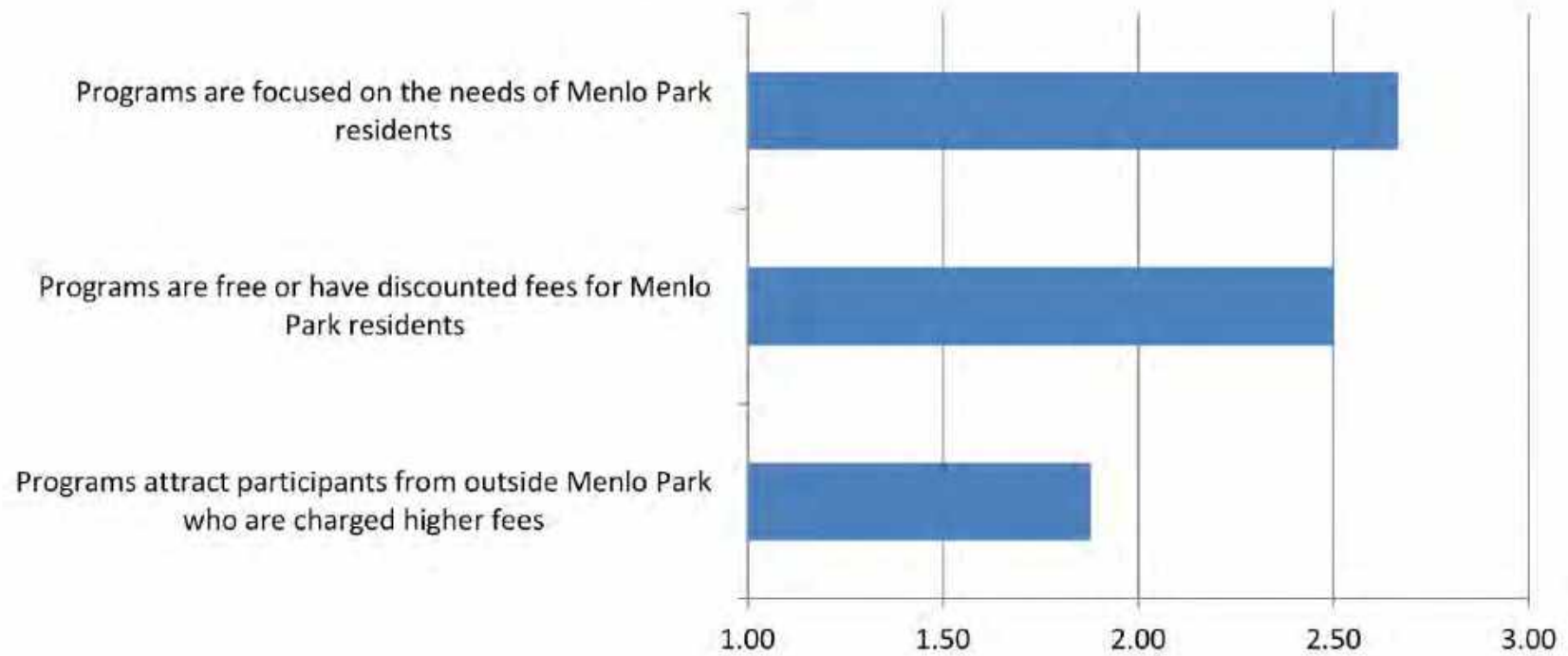

Chart shows average relative importance rated by survey respondents. Respondents rated each item as either "not at all important," "somewhat important," or "very important." Items rated "not important" are assigned a value of 1; "somewhat important" a value of 2; and "very important" a value of 3. The chart shows the average value of all ratings for each item. Higher average ratings indicate higher relative importance to the survey respondents.

Q15. For city library and information resources, how important are the following items?

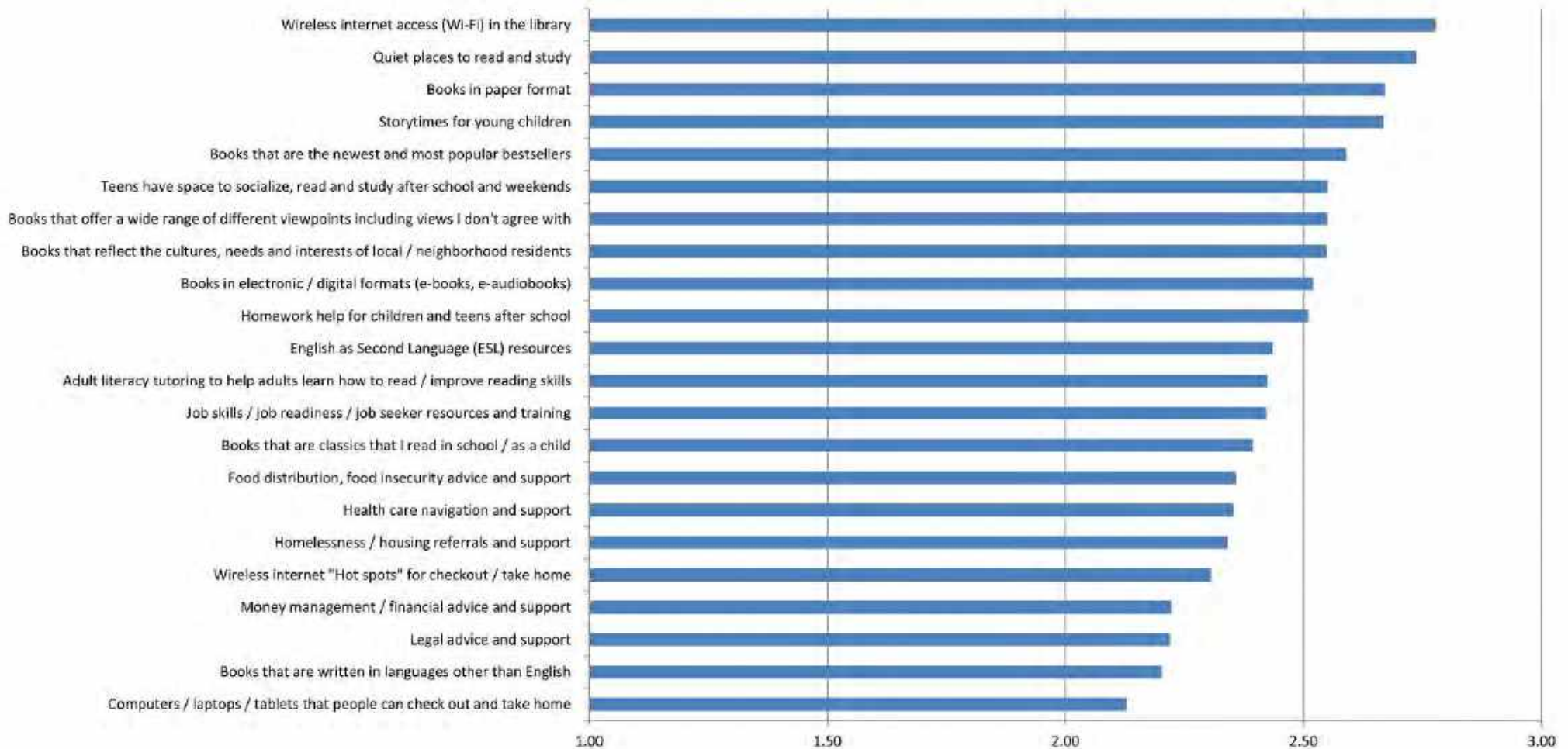

Chart shows average relative importance rated by survey respondents. Respondents rated each item as either "not at all important," "somewhat important," or "very important." Items rated "not important" are assigned a value of 1; "somewhat important" a value of 2; and "very important" a value of 3. The chart shows the average value of all ratings for each item. Higher average ratings indicate higher relative importance to the survey respondents.





Programming considerations

- Staff seeks City Council's feedback and direction on the survey considerations as well as any other elements that City Council desires to incorporate into the program planning process.



Programming considerations*

- A. Prioritize the program elements that survey respondents rated with the highest relative importance
- B. Include programs that aren't currently offered on a regular basis, but were rated with high importance by survey respondents, for example:
 - Homework help for children and teens after school
 - Job skills / job readiness / job seeker resources and training
 - Food insecurity advice and support
 - Health care navigation and support

* List is numbered for convenience only, in no particular order or priority



Programming considerations*

- C. Prioritize programs and classes that are free or have discounted fees for Menlo Park residents.
- D. Deprioritize programs that primarily attract participants from outside Menlo Park, and/or that survey respondents rated with low relative importance
- E. Prioritize casual and drop-in play opportunities for children and families, especially Menlo Park residents
- F. Aquatics program considerations will be addressed in the context of the upcoming aquatics operator request for proposals (RFP) process.

* List is numbered for convenience only, in no particular order or priority



Next steps

- Continue to work with stakeholders including the MPCC Subcommittee and working group, Library Commission, and Parks and Recreation Commission to develop the MPCC program planning
- Incorporate City Council's feedback and direction into the planning process and will present preliminary MPCC staffing and program options to City Council tentatively in January/February 2023.

